Replacement Parts Manual

Wall Mounted Package Air Conditioner

Models: **WL302, WL372**

General Notes

- Revised and/or additional pages may be issued from time to time.
- A complete and current manual consists of pages shown in the following contents section.

Important

- Contact the installing and/or local Bard distributor for all parts requirements. Make sure you have the complete model and serial number available from the unit rating plates.

Contents

Description	Page
Cabinet Components	
♦ Exploded View	1
♦ Usage List	2
Functional Components	
♦ Exploded View	3
♦ Usage List	4
Control Panel	
♦ Exploded View	5
♦ Usage List	6
Blower Assembly	
♦ Exploded View	7
♦ Usage List	7



CLIMATE CONTROL SOLUTIONS

BARD MANUFACTURING COMPANY
Bryan, Ohio 43506

Since 1914...Moving ahead, just as planned.

Manual: 2110-462
Supersedes:
File: Tab 16
Date: 04-01-02

CABINET COMPONENTS

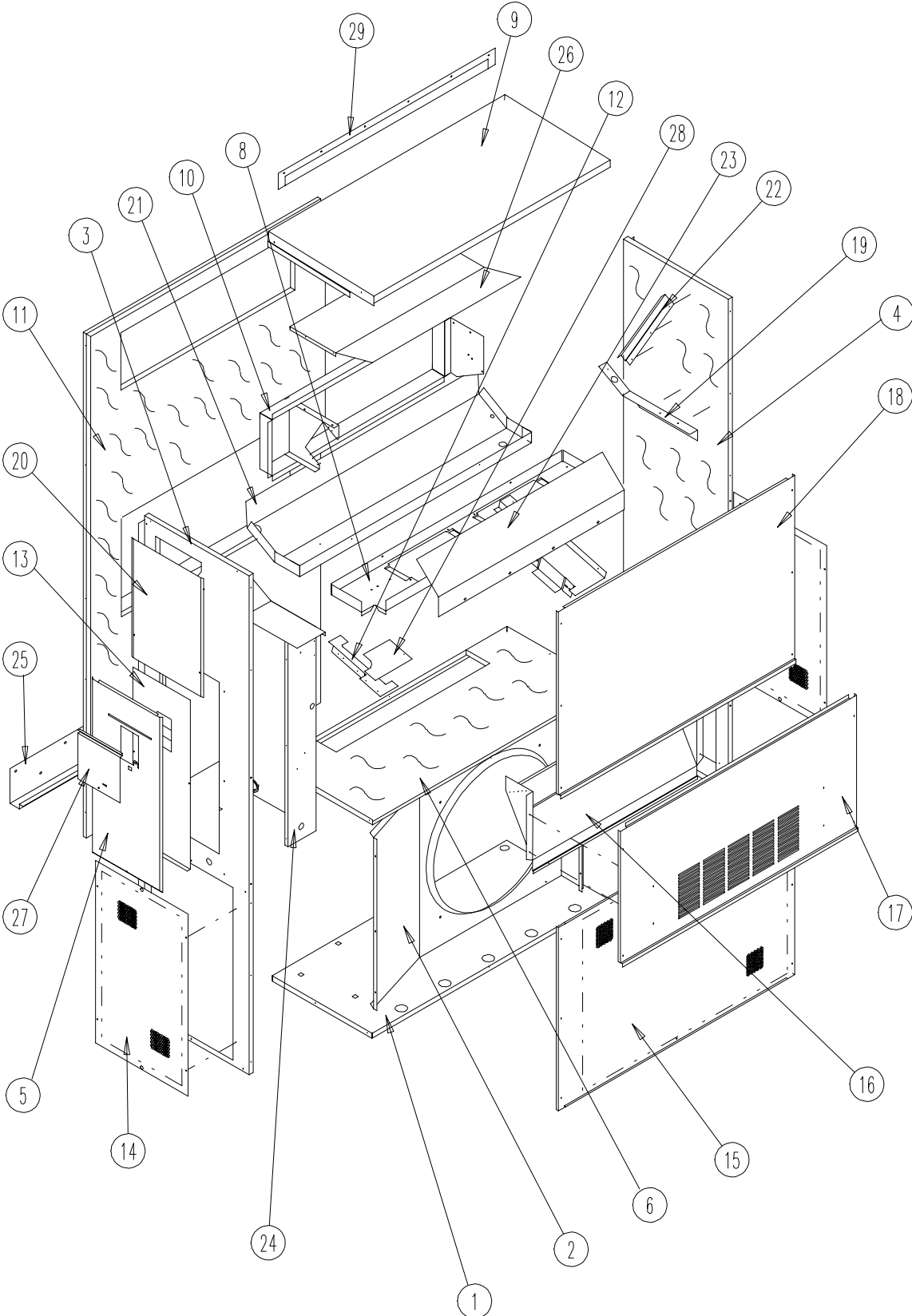

SEXP-227

CABINET COMPONENTS

Drawing No.	Part No.	Description	WL302-A,B	WL302-C	WL372-A,B	WL372-C
1	S127-199	Lower Base	X	X	X	X
2	125-022	Fan Shroud	X	X	X	X
3	S500-317-* ①	Right Side	X	X	X	X
4	S500-318-* ①	Left Side	X	X	X	X
5	S533-136-* ①	Control Panel Cover (Outer)	X	X	X	X
6	S521Y181	Condenser Partition	X	X	X	X
8	121Y182	Blower Partition	X	X	X	X
9	S506-130-* ①	Top	X	X	X	X
10	S111Y030	Outlet Airframe Assembly	X	X	X	X
11	S508-088	Back	X	X	X	X
12	113Y195	Filter Bracket	2	2	2	2
13	S132-104	Control Panel Cover (Inner)	X		X	
13	S132-172	Control Panel Cover (Inner)		X		X
14	118-028-* ①	Side Grille	2	2	2	2
15	118-029-* ①	Condenser Grille	X	X	X	X
16	962014	Fresh Air Damper Assembly	X	X	X	X
17	S552-206-* ①	Service Door	X	X	X	X
18	S514-072-* ①	Upper Front	X	X	X	X
19	105Y850	Left Side Support	X	X	X	X
20	S143-034-* ①	Side Cover Plate (Outer)	X	X	X	X
21	S123-090	Drain Pan	X	X	X	X
22	147-044-*	Right Evaporator Support	X	X	X	X
23	135-124	Air Baffle	X	X	X	X
24	Control Panel Assy.	See Control Panel Assembly Drawing and Parts List	X	X	X	X
25	113-140	Bottom Mounting Bracket	1	1	1	1
26	135Y123	Heat Shield	X	X	X	X
27	S153-218-* ①	Disconnect Access Door	X	X	X	X
28	137-259	Fill Plate	X	X	X	X
29	113-149-* ①	Top Rain Flashing	X	X	X	X

① NOTE: Exterior cabinet parts are manufactured with various paint color options. To insure that you receive the proper paint color, you must include the complete model and serial number of the unit for which cabinet parts are being ordered.

FUNCTIONAL COMPONENTS

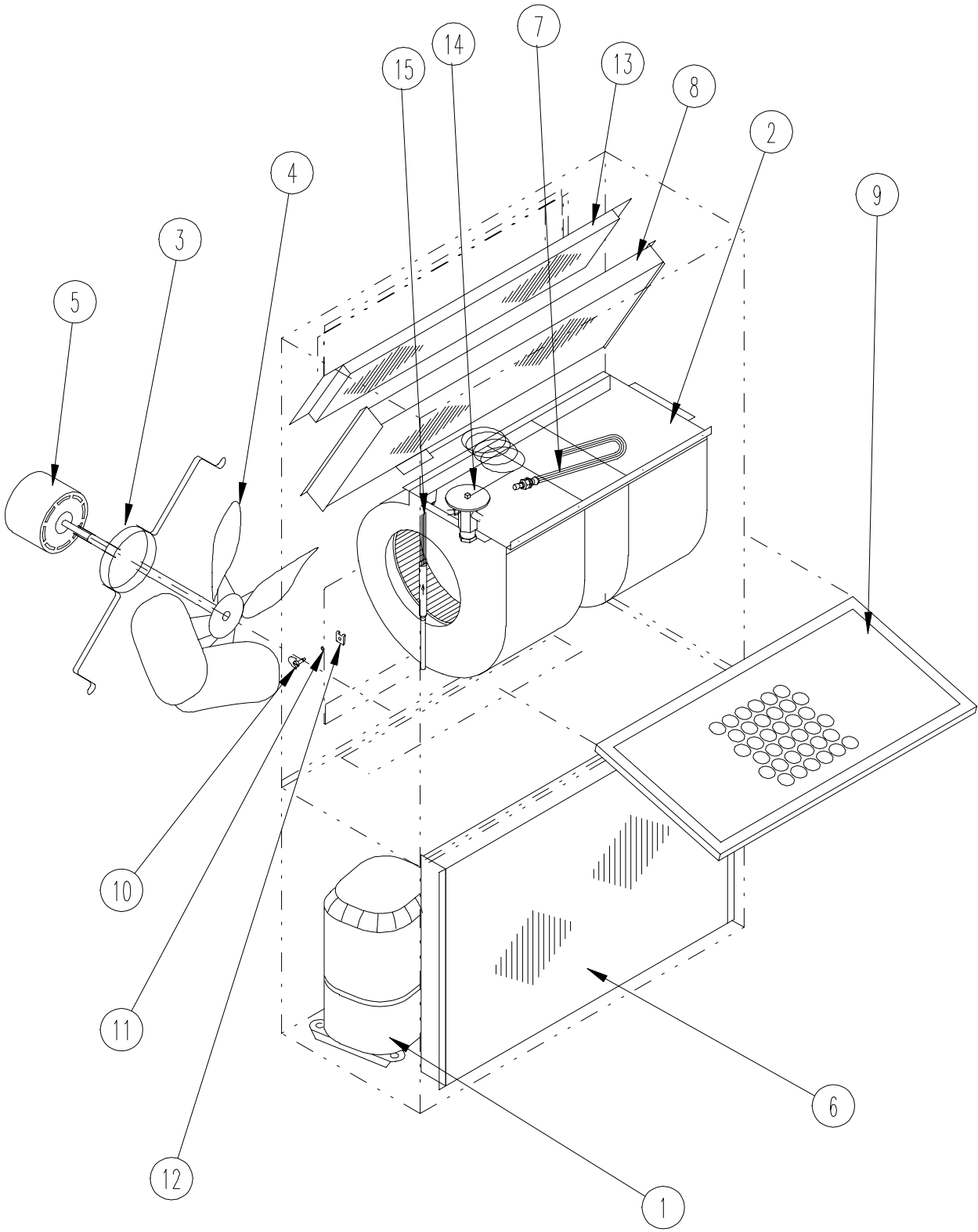

SEXP-228

FUNCTIONAL COMPONENTS

Drawing No.	Part No.	Description	WL302-A	WL302-B	WL302-C	WL372-A	WL372-B	WL372-C	WL372-F
1	8000-255	Compressor	X						
1	8000-203	Compressor		X					
1	8000-204	Compressor			X				
1	8000-225	Compressor				X			
1	8000-214	Compressor					X		
1	8000-217	Compressor						X	X
2	S900-231	Blower Assembly	X	X		X	X		X
2	S900-232	Blower Assembly			X			X	
3	8200-001	Fan Motor Mount	X	X	X	X	X	X	X
4	5151-045	Fan Blade	X	X	X	X	X	X	X
5	8103-013	Condenser Motor	X	X		X	X		X
5	8103-020	Condenser Motor			X			X	
6	5051-089	Condenser Coil	X	X	X	X	X	X	X
7	800-0185	Cooling Capillary Assembly				X	X	X	X
7	800-0184	Cooling Capillary Assembly	X	X	X				
8	5060-064	Evaporator Coil	X	X	X	X	X	X	X
9	7004-019	Air Filter 1" Throw-Away	X	X	X	X	X	X	X
9	7003-031	Air Filter 1" Washable (Optional)	X	X	X	X	X	X	X
9	7004-026	Air Filter 2" Pleated (Optional)	X	X	X	X	X	X	X
10	1171-002	1/4 Turn Fastener	X	X	X	X	X	X	X
11	1171-024	1/4 Turn Retainer	X	X	X	X	X	X	X
12	1171-023	1/4 Receptacle	X	X	X	X	X	X	X
NS	1804-0106	High Pressure Switch (Flare)	X	X	X	X	X	X	X
NS	1804-0107	Low Pressure Switch (Flare)	X	X	X	X	X	X	X
NS	CMA-6	Low Ambient Control (Flare)	X	X	X	X	X	X	X

NS — Not Shown

CONTROL PANEL

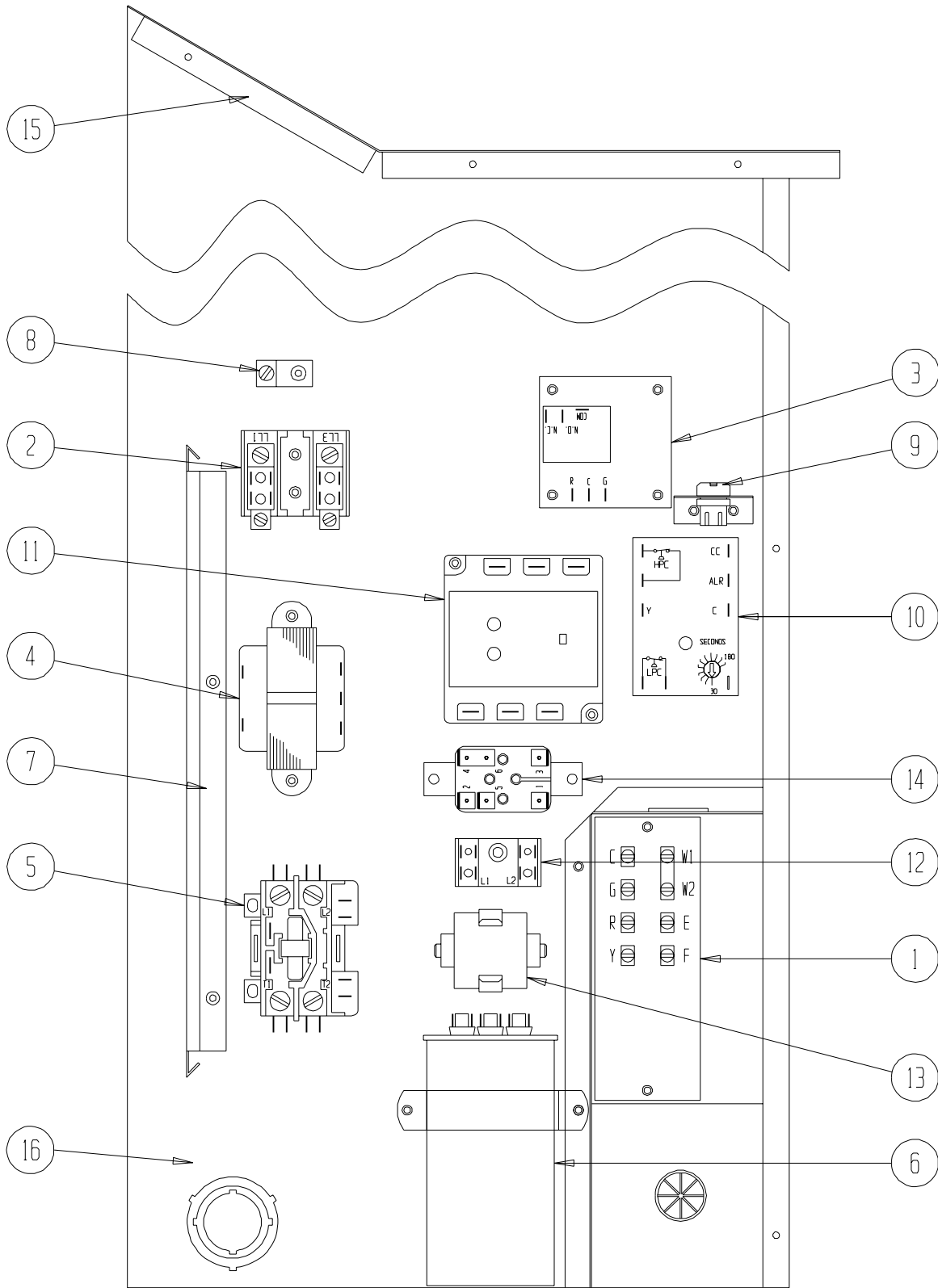

SEXP-290

CONTROL PANEL

Drawing No.	Part No.	Description	WL302-A	WL302-B	WL302-C	WL372-A	WL372-B	WL372-C	WL372-F
1	8607-020	Low Voltage Terminal Strip	X	X	X	X	X	X	X
2	8607-013	Terminal Block 2 Pole	X			X			2
2	8607-014	Terminal Block 3 Pole		X	X		X	X	
2	8607-015	Phenolic Insulator			X			X	
2	134-051	Phenolic Insulator							2
3	8201-056	Blower Control	X	X		X	X		X
3	8201-032	Blower Relay			X			X	
4	8407-034	Transformer	X	X		X	X		X
4	8407-042	Transformer			X			X	
5	8401-007	Compressor Contactor	X			X			
5	8401-002	Compressor Contactor		X	X		X	X	X
6	8552-049	Compressor Capacitor	X						
6	8552-051	Compressor Capacitor				X			
6	8552-002	Outdoor Motor Capacitor		X	X		X	X	X
7	135-122	Wire Shield	X	X	X	X	X	X	X
8	8611-006	Ground Terminal	X	X	X	X	X	X	X
9	3000-968	6 Pin Connector	X	X	X	X	X	X	X
10	8201-088	Compressor Control Module (Optional)	X	X	X	X	X	X	X
10	8201-050	Compressor TDR (Optional)	X	X	X	X	X	X	X
11	8201-085	Phase Monitor	X	X	X	X	X	X	X
12	8607-017	Terminal Block (Optional) (Shown)	X	X	X	X	X	X	X
13	8551-005	Start Device (PTCR) (Optional)	X	X	X	X	X	X	X
14	8201-062	Alarm Relay (Optional)	X	X	X	X	X	X	X
15	117-137	Control Panel Top	X	X	X	X	X	X	X
16	117-123	Control Panel	X	X	X	X	X	X	X
NS	8615-038	Circuit Breaker 35A 2 Pole (Optional)	X			X			
NS	8615-054	Circuit Breaker 20A 3 Pole (Optional)		X					
NS	8615-051	Circuit Breaker 25A 3 Pole (Optional)					X		
NS	8615-067	Toggle Disconnect			X			X	X
NS	4095-134	Wiring Diagram	X			X			
NS	4095-234	Wiring Diagram		X			X		
NS	4095-321	Wiring Diagram			X			X	
NS	4095-630	Wiring Diagram							X

NS — Not Shown

BLOWER ASSEMBLY

Drawing No.	Part No.	Description	900-231	900-232
1	151-111	Blower Housing	2	2
2	144-174	Diffuser	2	2
3	8105-029	Blower Motor (230/208)	X	
3	8105-033	Blower Motor (460)		X
4	8552-002	Capacitor	X	X
5	8200-031	Motor Mount	X	X
6	5451-011	Grommets	6	6
7	105-870	Back Brace	X	X
8	103-401	Front Brace	X	X
9	5152-090	Wheel (CW)	X	X
10	5152-091	Wheel (CCW)	X	X

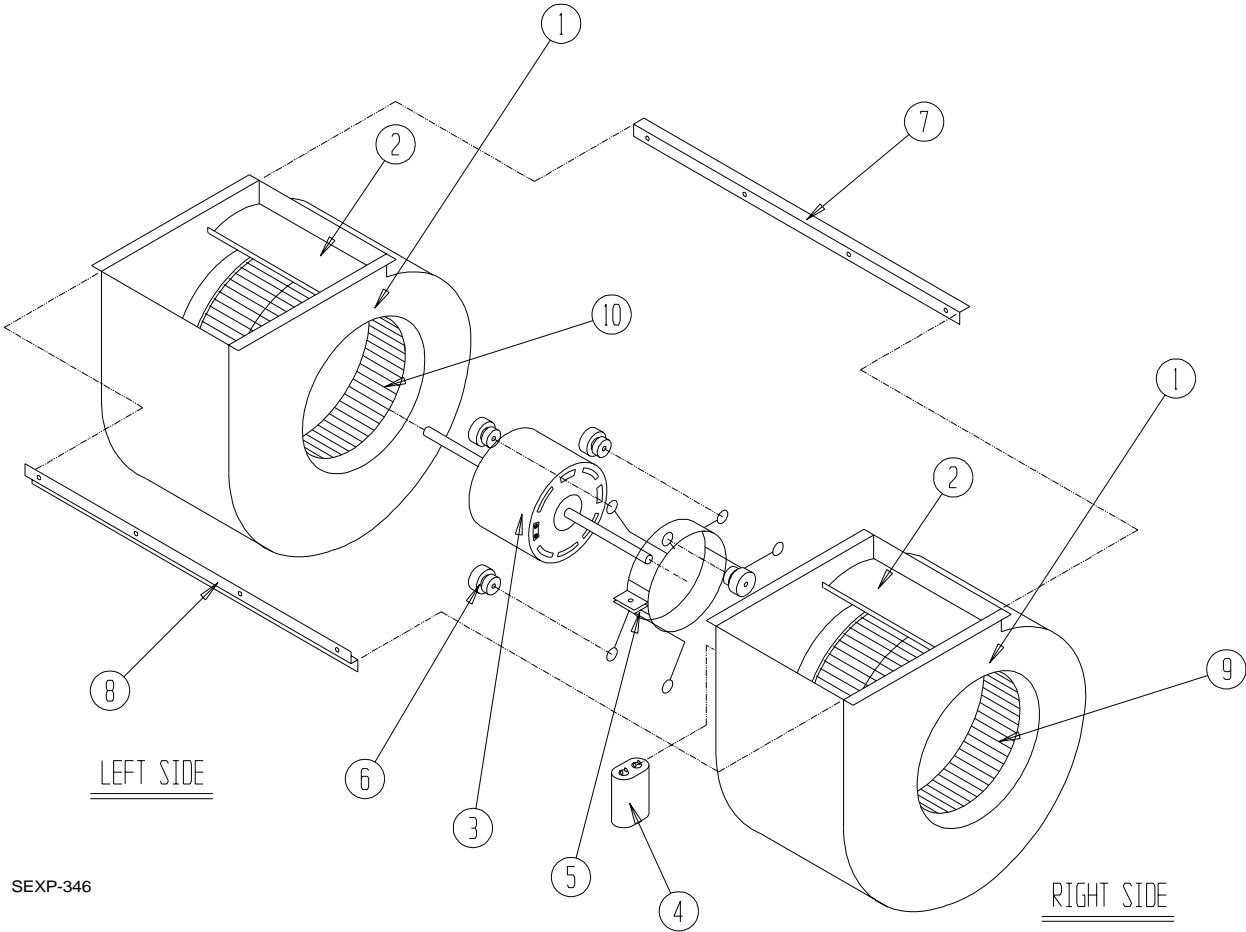

SEXP-346