

---

# REPLACEMENT PARTS MANUAL

# WALL MOUNTED PACKAGE AIR CONDITIONER

Models: **W30A1, W36A1**

---

## General Notes

- Revised and/or additional pages may be issued from time to time.
- A complete and current manual consists of pages shown in the following contents section.

## Important

- Contact the installing and/or local Bard distributor for all parts requirements. Make sure you have the complete model and serial number available from the unit rating plates.

## Contents

Description	Page
Cabinet Components	
♦ Exploded View .....	2
♦ Usage List .....	3
Functional Components	
♦ Exploded View .....	4
♦ Usage List .....	5
Control Panel	
♦ Exploded View .....	6
♦ Usage List .....	7
Blower Assembly	
♦ Exploded View .....	8
♦ Usage List .....	8



**Climate Control Solutions**

Bard Manufacturing Company, Inc.  
Bryan, Ohio 43506

*Since 1914...Moving ahead, just as planned.*

Manual: 2110-482C  
Supersedes: 2110-482B  
File: Tab 16  
Date: 04-26-10

# CABINET COMPONENTS

---

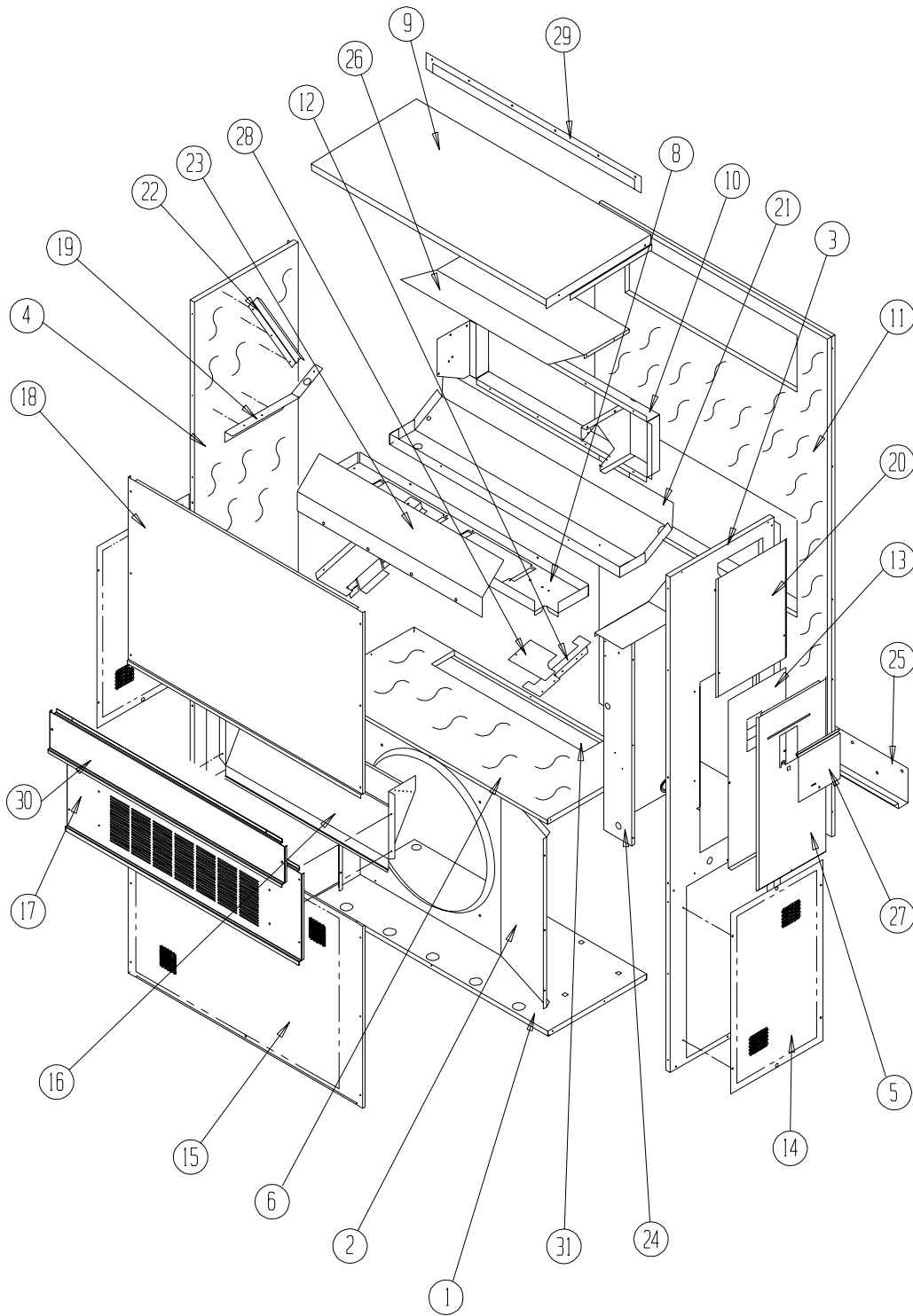

SEXP-514 A

# CABINET COMPONENTS

Drawing No.	Part No.	Description	W30A1-A,B,D	W30A1-C	W30A1-F	W36A1-A,B,D,E	W36A1-C	W36A1-F
1	S127-199	Lower Base	X	X	X	X	X	X
1	S127-368 ③	Lower Base	X	X	X	X	X	X
2	125-022	Fan Shroud	X	X	X	X	X	X
2	125-057 ③	Fan Shroud	X	X	X	X	X	X
3	S500-228-* ①	Right Side	X	X	X	X	X	X
3	S500-441 ②	Right Side	X	X	X	X	X	X
3	S500-527 ③	Right Side	X	X	X	X	X	X
4	S500-229-* ①	Left Side	X	X	X	X	X	X
4	S500-442 ②	Left Side	X	X	X	X	X	X
4	S500X528 ③	Left Side	X	X	X	X	X	X
5	S533-109-* ①	Control Panel Cover (Outer)	X	X	X	X	X	X
5	S533-182 ②	Control Panel Cover (Outer)	X	X	X	X	X	X
5	S533-197 ③	Control Panel Cover (Outer)	X	X	X	X	X	X
6	S521X384	Condenser Partition	X	X	X	X	X	X
8	121X182	Blower Partition	X	X	X	X	X	X
9	S506-130-* ①	Top	X	X	X	X	X	X
9	S506-245 ②	Top	X	X	X	X	X	X
9	S506-275 ③	Top	X	X	X	X	X	X
10	S111X030	Outlet Airframe Assembly	X	X	X	X	X	X
11	S508-088	Back	X	X	X	X	X	X
11	S508-185 ②	Back	X	X	X	X	X	X
11	S508-222 ③	Back	X	X	X	X	X	X
12	113X195	Filter Bracket	2	2	2	2	2	2
13	S132-104	Control Panel Cover (Inner)	X			X		
13	S132-172	Control Panel Cover (Inner)		X	X		X	X
14	118-056-* ①	Side Grille	2	2	2	2	2	2
14	118-060 ②	Side Grille	2	2	2	2	2	2
14	118-067 ③	Side Grille	2	2	2	2	2	2
15	118-059-* ①	Condenser Grille	X	X	X	X	X	X
15	118-061 ②	Condenser Grille	X	X	X	X	X	X
15	118-066 ③	Condenser Grille	X	X	X	X	X	X
16	BFAD-3	Fresh Air Damper Assembly	X	X	X	X	X	X
17	S552-443-* ①	Vent Option Door	X	X	X	X	X	X
17	S552-445-* ①	Vent Option Door with ERV	X	X	X	X	X	X
17	S552-446 ②	Vent Option Door	X	X	X	X	X	X
17	S552-458 ③	Vent Option Door	X	X	X	X	X	X
18	S514-160-* ①	Upper Front	X	X	X	X	X	X
18	S514-161 ②	Upper Front	X	X	X	X	X	X
18	S514-166 ③	Upper Front	X	X	X	X	X	X
19	105X850	Left Side Support	X	X	X	X	X	X
20	S143-034-* ①	Right Side Cover Plate (Outer)	X	X	X	X	X	X
20	S143-103 ②	Right Side Cover Plate (Outer)	X	X	X	X	X	X
20	S143-127 ③	Right Side Cover Plate (Outer)	X	X	X	X	X	X
21	S123-078	Drain Pan	X	X	X	X	X	X
22	147-044	Evaporator Support	X	X	X	X	X	X
23	135-124	Air Baffle	X	X	X	X	X	X
24	Control Panel Assembly	See Control Panel Assembly Drawing and Parts List	X	X	X	X	X	X
25	113-140	Bottom Mounting Bracket	1	1	1	1	1	1
26	135X123	Heat Shield	X	X	X	X	X	X
27	S153-218-* ①	Disconnect Access Door	X	X	X	X	X	X
27	S153-387 ②	Disconnect Access Door	X	X	X	X	X	X
27	S153-405 ③	Disconnect Access Door	X	X	X	X	X	X
28	137-259	Fill Plate	X	X	X	X	X	X
29	113-149-* ①	Top Rain Flashing	X	X	X	X	X	X
29	113-360 ③	Top Rain Flashing	X	X	X	X	X	X
30	S552-444-* ①	Filter Door	X	X	X	X	X	X
30	S552-447 ②	Filter Door	X	X	X	X	X	X
30	S552-459 ③	Filter Door	X	X	X	X	X	X
31	S536-498	Condenser Partition Block-Off Plate	X	X	X	X	X	X

① Exterior cabinet parts are manufactured with various paint color options. To insure that you receive the proper paint color, you must include the complete model and serial number of the unit for which cabinet parts are being ordered.

② Note: Exterior cabinet parts are manufactured from aluminum Code "A"

③ Note: Exterior cabinet parts are manufactured from stainless steel Code "S"

# FUNCTIONAL COMPONENTS

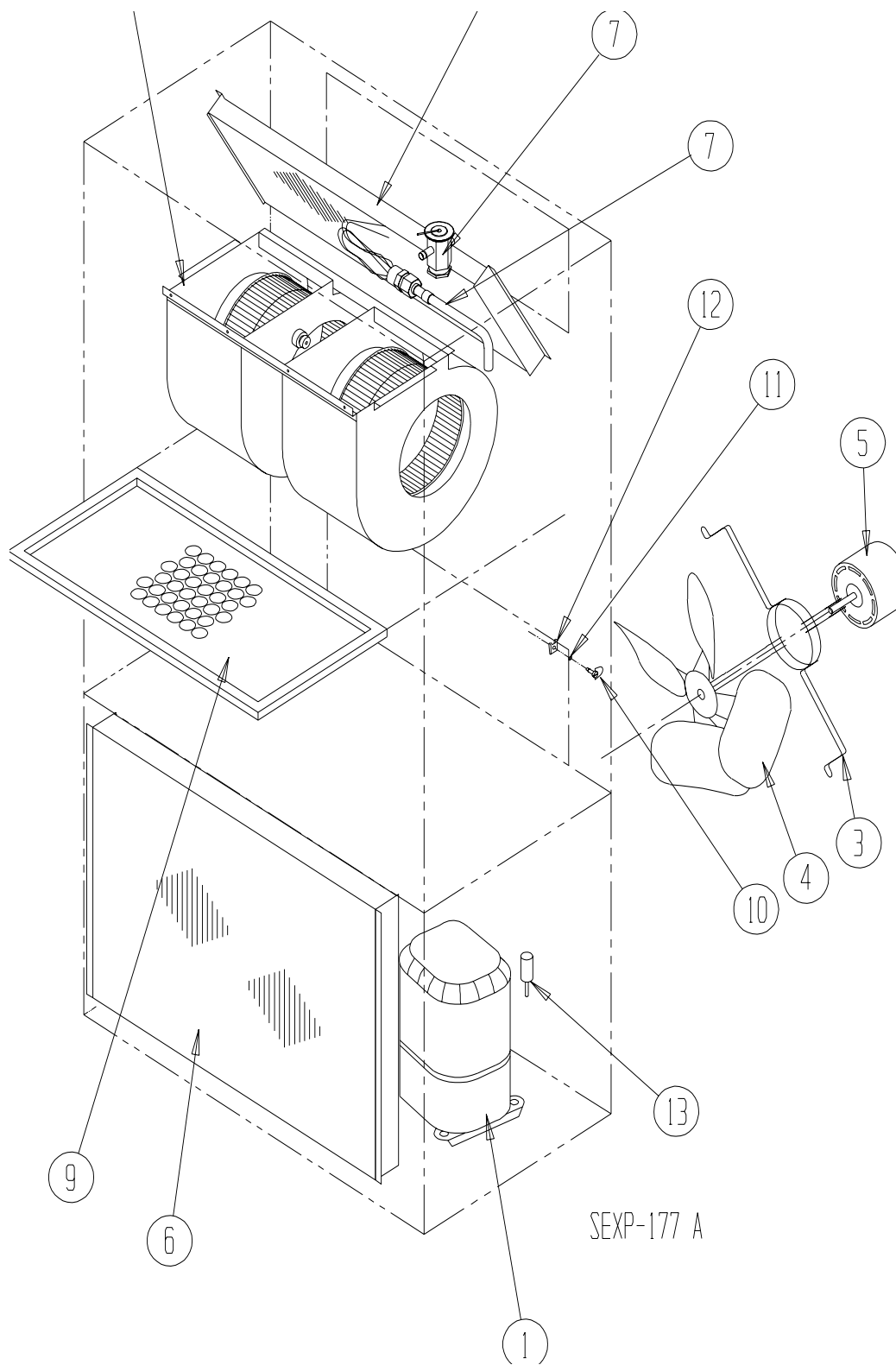

# FUNCTIONAL COMPONENTS

Drawing No.	Part No.	Description	W30A1-A	W30A1-B	W30A1-C	W30A1-D	W30A1-F	W36A1-A	W36A1-B	W36A1-C	W36A1-D	W36A1-E	W36A1-F
1	8000-298	Compressor	X										
1	8000-299	Compressor		X									
1	8000-300	Compressor			X		X						
1	8000-301	Compressor				X							
1	8000-309	Compressor					X						
1	8000-310	Compressor						X				X	
1	8000-311	Compressor							X				X
1	8000-312	Compressor								X			
2	S900-231	Blower Assembly	X	X		X	X	X	X		X	X	X
2	S900-232	Blower Assembly			X					X			
3	8200-001	Fan Motor Mount	X	X	X	X	X	X	X	X	X	X	X
4	5151-045	Fan Blade	X	X	X	X	X	X	X	X	X	X	X
5	8103-013	Condenser Motor	X	X		X	X	X			X	X	X
5	8103-020	Condenser Motor			X					X			
6	5051-068BX	Condenser Coil	X	X	X	X	X						
6	5051-066BX	Condenser Coil						X	X	X	X	X	X
7	800-0366	Cooling Distributor Assembly						X	X	X	X	X	X
7	800-0368	Cooling Distributor Assembly	X	X	X	X	X						
8	5060-135BX	Evaporator Coil	X	X	X	X	X						
8	5060-064BX	Evaporator Coil						X	X	X	X	X	X
9	7004-019	Air Filter 1" Throw-Away	X	X	X	X	X	X	X	X	X	X	X
9	7003-031	Air Filter 1" Washable ①	X	X	X	X	X	X	X	X	X	X	X
9	7004-026	Air Filter 2" Pleated ①	X	X	X	X	X	X	X	X	X	X	X
10	1171-022	1/4 Turn Fastener	X	X	X	X	X	X	X	X	X	X	X
11	1171-024	1/4 Turn Retainer	X	X	X	X	X	X	X	X	X	X	X
12	1171-023	1/4 Turn Receptacle	X	X	X	X	X	X	X	X	X	X	X
13	1804-0385	High Pressure Switch (Flare)	X	X	X	X	X	X	X	X	X	X	X
13	1804-0386	Low Pressure Switch (Flare)	X	X	X	X	X	X	X	X	X	X	X
NS	5201-001	Filter Drier	X	X	X	X	X	X	X	X	X	X	X
NS	CMA-28	Low Ambient Control (Flare) ①	X	X	X	X	X	X	X	X	X	X	X

NS – Not Shown

① – Optional

# CONTROL PANEL

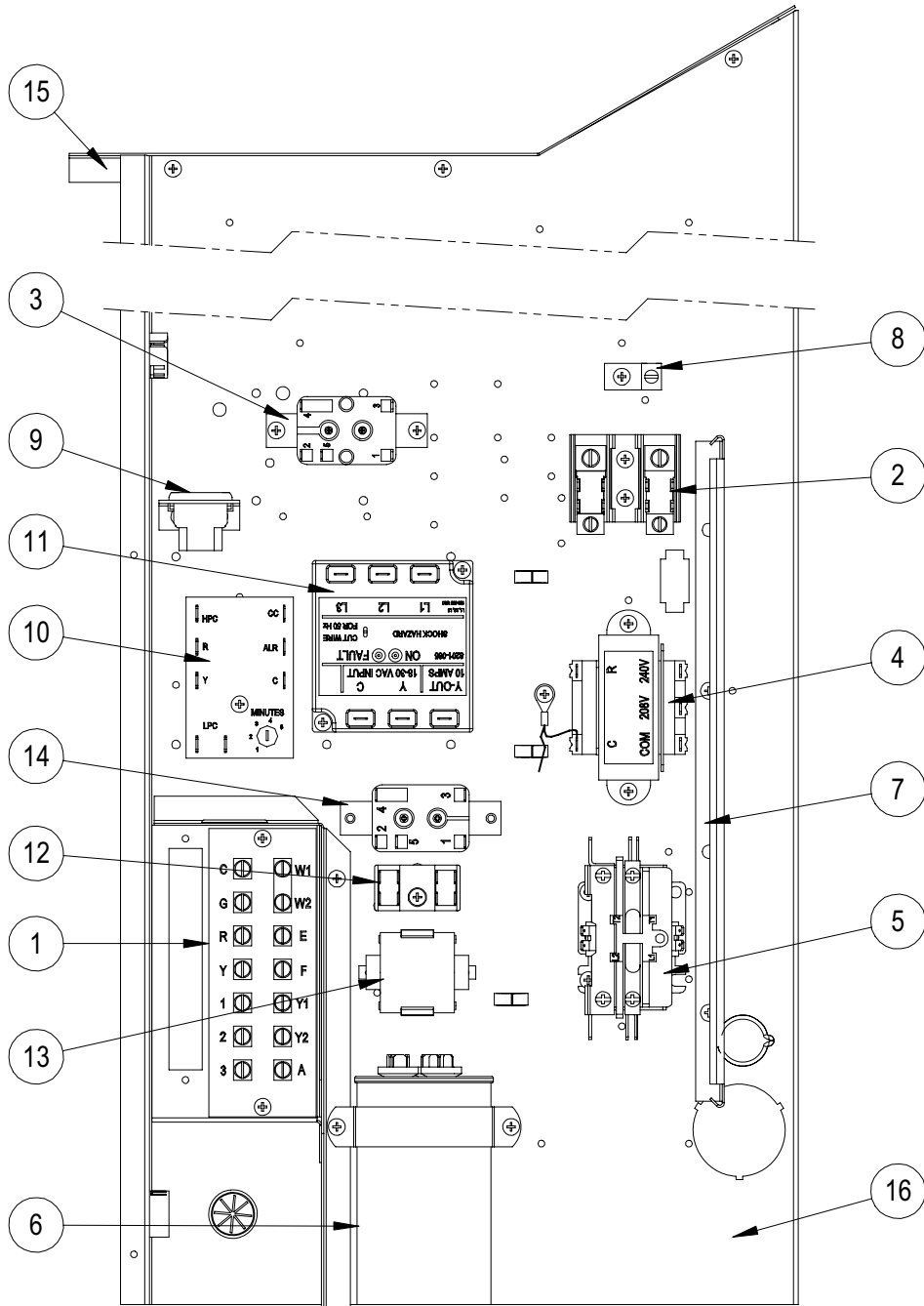

SEXP-515

# CONTROL PANEL

Drawing No.	Part No.	Description	W30A1-A	W30A1-B	W30A1-C	W30A1-D	W30A1-F	W36A1-A	W36A1-B	W36A1-C	W36A1-D	W36A1-E	W36A1-F
1	8607-024	Low Voltage Terminal Strip	X	X	X	X	X	X	X	X	X	X	X
2	8607-013	Terminal Block 2 Pole	X			X	2	X			X		2
2	8607-014	Terminal Block 3 Pole		X	X				X	X		X	
2	8607-015	Phenolic Insulator			X		2			X			2
2	134-051	Phenolic Insulator					2						2
3	8201-009	Blower Control Relay	X	X		X	X	X	X		X	X	X
3	8201-032	Blower Control Relay			X					X			
4	8407-034	Transformer	X	X		X	X	X	X		X	X	X
4	8407-042	Transformer			X					X			
5	8401-007	Compressor Contactor	X			X		X			X		
5	8401-002	Compressor Contactor		X	X		X		X	X	X	X	X
6	8552-052	Compressor Capacitor	X					X					
6	8552-002	Outdoor Motor Capacitor		X	X		X		X	X		X	X
6	8552-062	Compressor Capacitor				X					X		
7	135-122	Wire Shield	X	X	X	X	X	X	X	X	X	X	X
8	8611-006	Ground Terminal	X	X	X	X	X	X	X	X	X	X	X
9	3000-968	6 Pin Connector	X	X	X	X	X	X	X	X	X	X	X
10	8201-088	Compressor Control Module (Optional)	X	X	X	X	X	X	X	X	X	X	X
11	8201-085	Phase Monitor		X	X		X		X	X		X	X
12	8607-017	Terminal Block (Optional)	X	X	X	X	X	X	X	X	X	X	X
13	8551-004	Start Device (PTRC) (Optional)	X			X		X			X		
14	8201-062	Alarm Relay (Optional)	X	X	X	X	X	X	X	X	X	X	X
15	117-137	Control Panel Top	X	X	X	X	X	X	X	X	X	X	X
16	117-123	Control Panel	X	X	X	X	X	X	X	X	X	X	X
NS	8615-038	Circuit Breaker 35A 2 Pole (Opt) ①	X			X		X			X		
NS	8615-054	Circuit Breaker 20A 3 Pole (Opt) ①		X									
NS	8615-052	Circuit Breaker 30A 3 Pole (Opt) ①							X			X	
NS	8615-067	Toggle Disconnect (Optional)			X		X			X			X
NS	4095-143	Wiring Diagram	X			X		X			X		
NS	4095-242	Wiring Diagram		X					X			X	
NS	4095-342	Wiring Diagram			X					X			
NS	4095-632	Wiring Diagram					X						X

NS – Not Shown

① Circuit breakers listed are for units without electric heat "0Z" models.  
See Heater Replacement Parts Manual for units with electric heat.

# BLOWER ASSEMBLY

Drawing No.	Part No.	Description	900-231	900-232
1	151-111	Blower Housing	2	2
2	144-174	Diffuser	2	2
3	8105-029	Blower Motor (230/208)	X	
3	8105-033	Blower Motor (460)		X
4	8552-002	Capacitor	X	X
5	8200-031	Motor Mount	X	X
6	5451-011	Grommets	6	6
7	105-870	Back Brace	X	X
8	103-401	Front Brace	X	X
9	5152-090	Wheel (CW)	X	X
10	5152-091	Wheel (CCW)	X	X

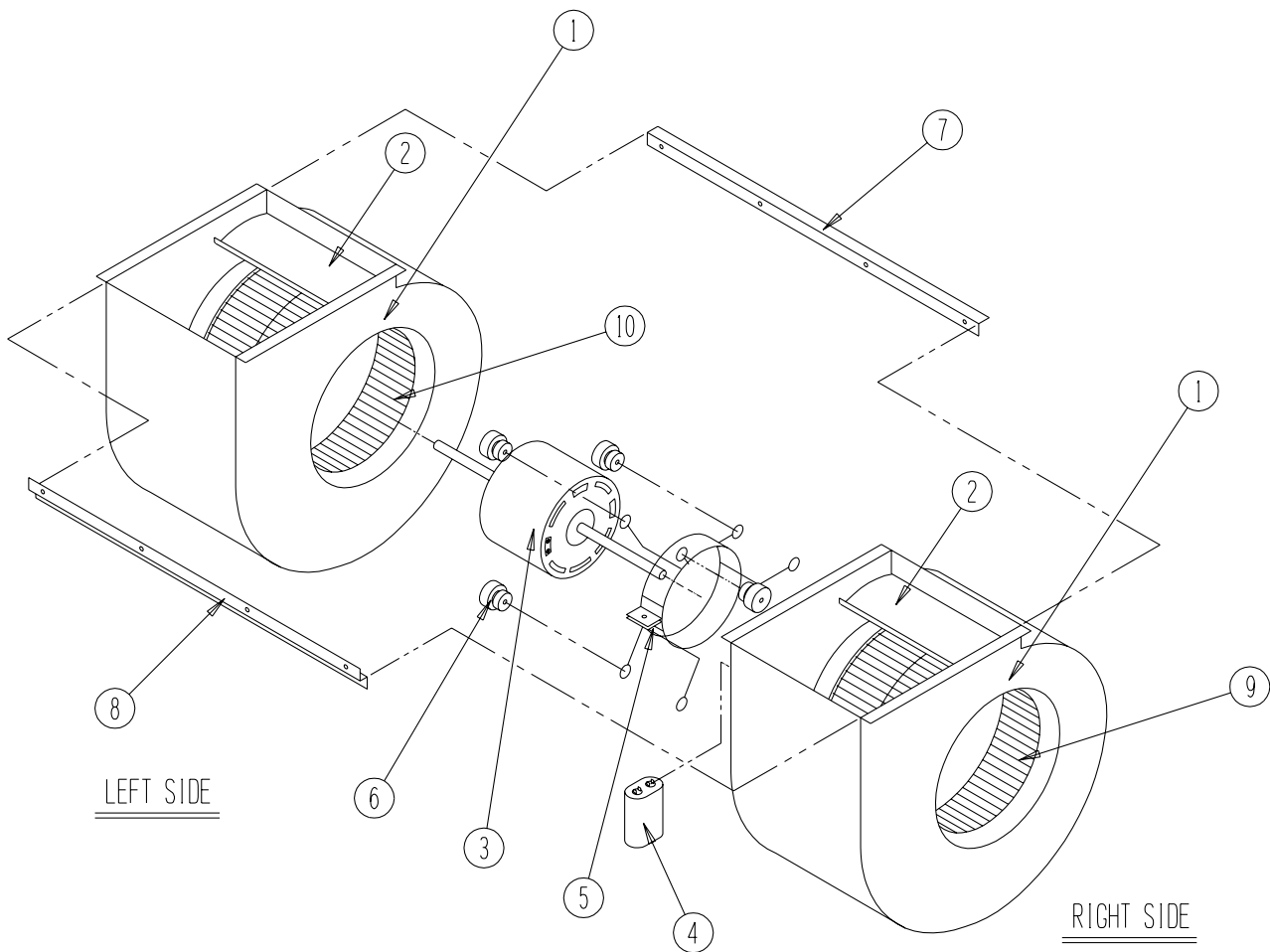

SEXP-346