REPLACEMENT PARTS MANUAL

WALL MOUNTED PACKAGE AIR CONDITIONER

Models: **W42L1**
W48L1
W60L1

General Notes

- Revised and/or additional pages may be issued from time to time.
- A complete and current manual consists of pages shown in the following contents section.

Important

- Contact the installing and/or local Bard distributor for all parts requirements. Make sure you have the complete model and serial number available from the unit rating plates.

Contents

Description	Page
Cabinet Components	
♦ Exploded View	2
♦ Usage List	3
Functional Components	
♦ Exploded View	4
♦ Usage List	5
Control Panel	
♦ Exploded View	6
♦ Usage List	7
Blower Assembly	
♦ Exploded View	8
♦ Usage List	8



Climate Control Solutions

Bard Manufacturing Company, Inc.
Bryan, Ohio 43506

Since 1914...Moving ahead, just as planned.

Manual: 2110-484E
Supersedes: 2110-484D
File: Tab 16
Date: 11-18-10

CABINET COMPONENTS

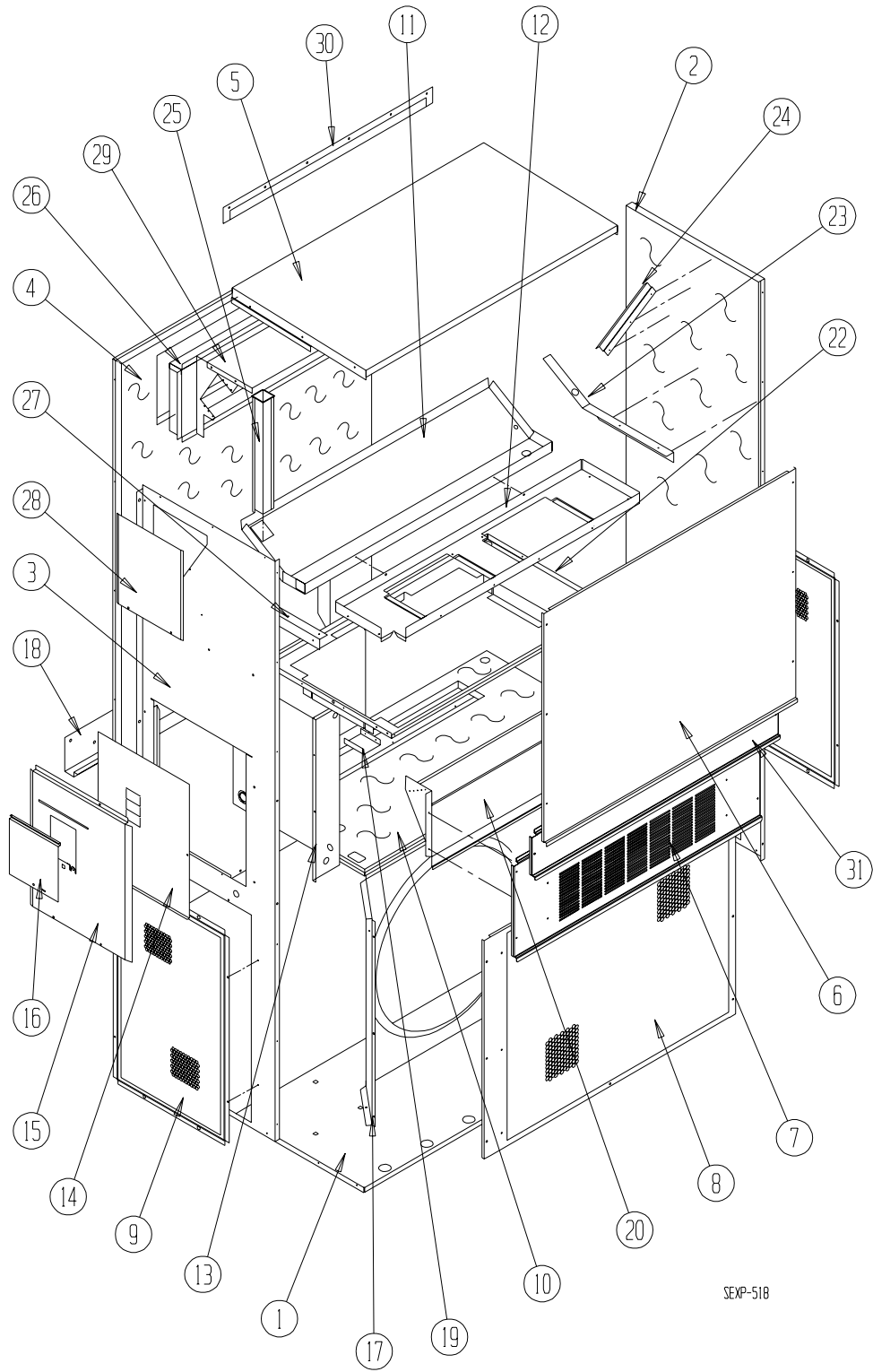

SEXP-518

CABINET COMPONENTS

Drawing No.	Part No.	Description	W42L1-A, B	W42L1-C, F	W48L1-A, B	W48L1-C, F	W60L1-A, B	W60L1-C, F
1	S127Y214	Lower Base	X	X	X	X	X	X
1	S127Y369 ①	Lower Base	X	X	X	X	X	X
2	S500-319-* ①	Right Side	X	X	X	X	X	X
2	S500-465 ②	Right Side	X	X	X	X	X	X
2	S500Y516 ③	Right Side	X	X	X	X	X	X
3	S500-320-* ①	Left Side	X	X	X	X	X	X
3	S500-466 ②	Left Side	X	X	X	X	X	X
3	S500-519 ③	Left Side	X	X	X	X	X	X
4	S508-098	Back	X	X	X	X	X	X
4	S508-191 ②	Back	X	X	X	X	X	X
4	S508-221 ③	Back	X	X	X	X	X	X
5	S506-142-* ①	Top	X	X	X	X	X	X
5	S506-251 ②	Top	X	X	X	X	X	X
5	S506-274 ③	Top	X	X	X	X	X	X
6	S515-144-* ①	Upper Front	X	X	X	X	X	X
6	S514-142 ②	Upper Front	X	X	X	X	X	X
6	S514-162 ③	Upper Front	X	X	X	X	X	X
7	S553-383-* ①	Vent Option Door	X	X	X	X	X	X
7	S552-456 ②	Vent Option Door	X	X	X	X	X	X
7	S553-449 ③	Vent Option Door	X	X	X	X	X	X
8	118-049-* ①	Condenser Grille	X	X	X	X	X	X
8	118-065 ②	Condenser Grille	X	X	X	X	X	X
8	118-074 ③	Condenser Grille	X	X	X	X	X	X
9	118-057-* ①	Side Grille	2	2	2	2	2	2
9	118-063 ②	Side Grille	2	2	2	2	2	2
9	118-073 ③	Side Grille	2	2	2	2	2	2
10	S521Y258	Condenser Partition	X	X	X	X	X	X
11	123-091	Drain Pan	X	X	X	X	X	X
12	121Y216	Blower Partition	X	X	X	X	X	X
13	Control Panel Assembly	See Control Panel Assembly Drawing & Parts List	X	X	X	X	X	X
14	S133-114	Control Panel Cover (Inner)	X		X		X	
14	S133-171	Control Panel Cover (Inner)		X		X		X
15	S533-140-* ①	Control Panel Cover (Outer)	X	X	X	X	X	X
15	S533-186 ②	Control Panel Cover (Outer)	X	X	X	X	X	X
15	S533-203 ③	Control Panel Cover (Outer)	X	X	X	X	X	X
16	S153-218-* ①	Disconnect Access Door	X	X	X	X	X	X
16	S153-387 ②	Disconnect Access Door	X	X	X	X	X	X
16	S153-405 ③	Disconnect Access Door	X	X	X	X	X	X
17	125-024	Fan Shroud	X	X	X	X	X	X
17	125-058 ③	Fan Shroud	X	X	X	X	X	X
18	113-140	Bottom Mounting Bracket	X	X	X	X	X	X
19	137-209	Fill	X	X	X	X	X	X
20	BFAD-5	Fresh Air Damper Assembly	X	X	X	X	X	X
22	131Y099	Filter Tray	X	X	X	X	X	X
23	105Y878	Left Side Support	X	X	X	X	X	X
24	147-046	Left Evaporator Support	X	X	X	X	X	X
25	135-128	Raceway	2	2	2	2	2	2
26	S111Y034	Outlet Air Frame Assembly	X	X	X	X	X	X
27	105Y877	Right Side Support	X	X	X	X	X	X
28	S143-042-* ①	Right Side Cover Plate (Outer)	X	X	X	X	X	X
28	S143-105 ②	Right Side Cover Plate (Outer)	X	X	X	X	X	X
28	S143-125 ③	Right Side Cover Plate (Outer)	X	X	X	X	X	X
29	135-129	Heat Shield	X	X	X	X	X	X
30	113-150-* ①	Top Rain Flashing	X	X	X	X	X	X
30	113-359 ③	Top Rain Flashing	X	X	X	X	X	X
31	S553-384-* ①	Filter Door Assembly	X	X	X	X	X	X
31	S552-457 ②	Filter Door Assembly	X	X	X	X	X	X
31	S553-450 ③	Filter Door Assembly	X	X	X	X	X	X
NS	S536-498	Condenser Partition Block Off Plate	X	X	X	X	X	X

① Exterior cabinet parts are manufactured with various paint color options. To insure that you receive the proper paint color, you must include the complete model and serial number of the unit for which cabinet parts are being ordered.

② Note: Exterior cabinet parts are manufactured from aluminum Code "A"

NS = Not Shown

③ Note: Exterior cabinet parts are manufactured from stainless steel Code "S"

FUNCTIONAL COMPONENTS

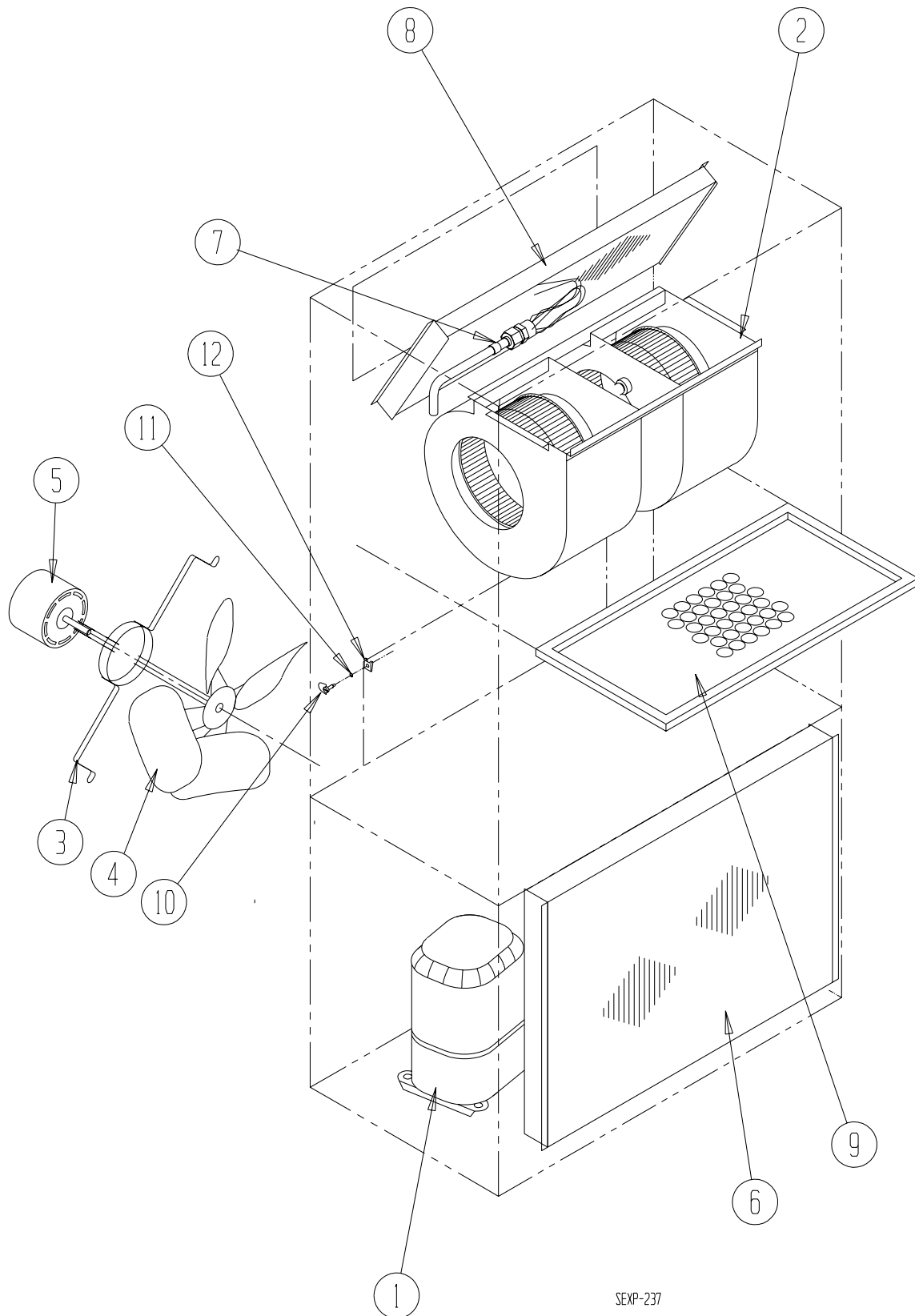

SEXP-237

FUNCTIONAL COMPONENTS

Drawing No.	Part No.	Description	W42L1-A	W42L1-B	W42L1-C	W42L1-F	W48L1-A	W48L1-B	W48L1-C	W48L1-F	W60L1-A	W60L1-B	W60L1-C	W60L1-F
1	8000-318	Compressor	X											
1	8000-319	Compressor		X										
1	8000-320	Compressor			X	X								
1	8000-343	Compressor					X							
1	8000-344	Compressor						X						
1	8000-345	Compressor							X	X				
1	8000-324	Compressor									X			
1	8000-325	Compressor										X		
1	8000-326	Compressor											X	X
2	S900-183	Blower Assembly	X	X		X	X	X	X	X				
2	S900-184	Blower Assembly			X				X					
2	S900-185	Blower Assembly									X	X		X
2	S900-186	Blower Assembly											X	
3	8200-004	Fan Motor Mount	X	X	X	X	X	X	X	X	X	X	X	X
4	5151-027	Fan Blade	X	X	X	X	X	X	X	X	X	X	X	X
5	8105-030	Condenser Motor			X				X				X	
5	8105-039	Condenser Motor	X	X		X	X		X	X	X			X
6	5051-152BX	Condenser Coil	X	X	X	X	X	X	X	X				
6	5051-153BX	Condenser Coil									X	X	X	X
7	800-0367	Distributor Assembly	X	X	X	X								
7	800-0369	Distributor Assembly					X	X	X	X				
7	800-0370	Distributor Assembly									X	X	X	X
8	5060-070BX	Evaporator Coil					X	X	X	X				
8	5060-082BX	Evaporator Coil									X	X	X	X
8	5060-113BX	Evaporator Coil	X	X	X	X								
9	7004-016	Air Filter 1" Throw-Away	X	X	X	X	X	X	X	X	X	X	X	X
9	7003-030	Air Filter 1" Washable	X	X	X	X	X	X	X	X	X	X	X	X
9	7004-027	Air Filter 2" Pleated	X	X	X	X	X	X	X	X	X	X	X	X
10	1171-022	1/4 Turn Fastener	X	X	X	X	X	X	X	X	X	X	X	X
11	1171-024	1/4 Turn Retainer	X	X	X	X	X	X	X	X	X	X	X	X
12	1171-023	1/4 Turn Receptacle	X	X	X	X	X	X	X	X	X	X	X	X
NS	5201-002	Filter Drier	X	X	X	X	X	X	X	X	X	X	X	X
NS	CMA-28	Low Ambient Control	X	X	X	X	X	X	X	X	X	X	X	X
NS	1804-0385	High Pressure Switch (Flare)	X	X	X	X	X	X	X	X	X	X	X	X
NS	1804-0386	Low Pressure Switch (Flare)	X	X	X	X	X	X	X	X	X	X	X	X

NS = Not Shown

CONTROL PANEL

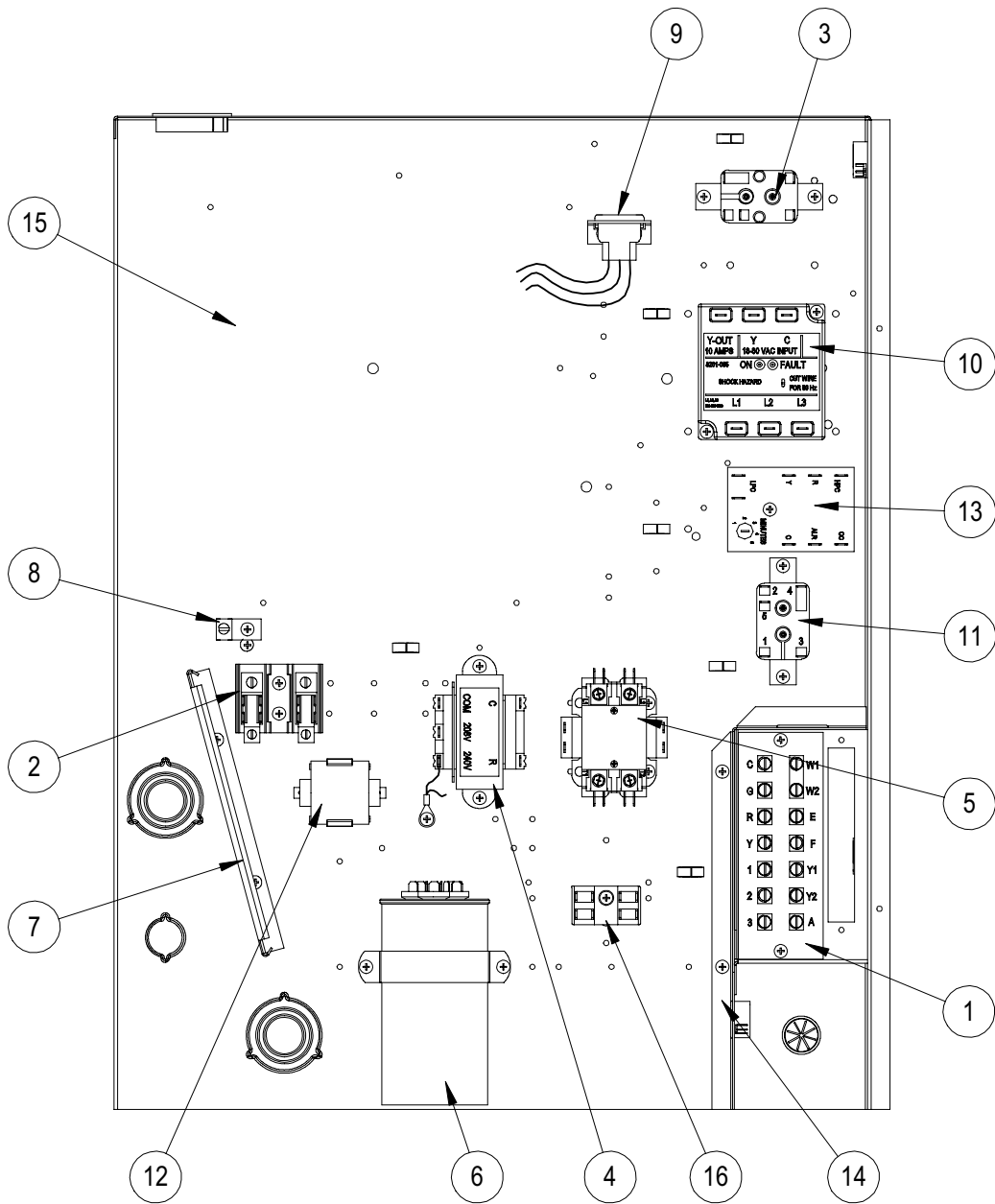

SEXP-519

CONTROL PANEL

Drawing No.	Part No.	Description	W42L1-A	W42L1-B	W42L1-C	W42L1-F	W48L1-A	W48L1-B	W48L1-C	W48L1-F	W60L1-A	W60L1-B	W60L1-C	W60L1-F
1	8607-024	Low Voltage Terminal Strip	X	X	X	X	X	X	X	X	X	X	X	X
2	8607-013	Terminal Block 2 Pole	X			2	X			2	X			2
2	8607-014	Terminal Block 3 Pole		X	X			X	X			X	X	
2	8607-015	Phenolic Insulator			X				X				X	
2	134-051	Terminal Block Barrier				2				2				2
3	8201-009	Blower Control Relay	X	X		X	X	X		X	X	X		X
3	8201-032	Blower Control Relay			X				X				X	
4	8407-034	Transformer	X	X		X	X	X		X	X	X		X
4	8407-042	Transformer			X				X				X	
5	8401-002	Compressor Contactor		X	X	X		X	X	X		X	X	X
5	8401-025	Compressor Contactor	X				X				X			
6	8552-079	Compressor Capacitor	X											
6	8552-005	Outdoor Motor Capacitor		X		X		X		X				
6	8552-026	Outdoor Motor Capacitor			X			X					X	
6	8552-059	Compressor Capacitor					X							
6	8552-089	Compressor Capacitor									X			
6	8552-004	Compressor Capacitor										X		X
7	135-130	Wire Shield	X	X	X	X	X	X	X	X	X	X	X	X
8	8611-006	Ground Terminal	X	X	X	X	X	X	X	X	X	X	X	X
9	3000-978	6 Pin Connector	X	X	X	X	X	X	X	X	X	X	X	X
10	8201-085	Phase Monitor		X	X	X		X	X	X		X	X	X
11	8201-062	Alarm Relay (Optional)	X	X	X	X	X	X	X	X	X	X	X	X
12	8551-004	Start Device (PTRC) (Optional)	X				X				X			
13	8201-088	Compressor Control Module	X	X	X	X	X	X	X	X	X	X	X	X
14	117-139	Low Voltage Box	X	X	X	X	X	X	X	X	X	X	X	X
15	117-143	Control Panel	X	X	X	X	X	X	X	X	X	X	X	X
16	8607-017	Terminal Block (Optional)	X	X	X	X	X	X	X	X	X	X	X	X
NS	8615-040	Circuit Breaker 50A 2 Pole ②	X				X							
NS	8615-042	Circuit Breaker 35A 3 Pole ②		X				X						
NS	8615-067	Toggle Disconnect ②			X	X			X	X			X	X
NS	8615-044	Circuit Breaker 45A 3 Pole ②										X		
NS	8615-041	Circuit Breaker 60A 2 Pole ②									X			
NS	4095-137	Wiring Diagram	X											
NS	4095-128	Wiring Diagram					X				X			
NS	4095-234	Wiring Diagram		X										
NS	4095-227	Wiring Diagram						X				X		
NS	4095-321	Wiring Diagram			X									
NS	4095-318	Wiring Diagram							X				X	
NS	4095-634	Wiring Diagram				X				X				X

① Optional on these models.

② Circuit breakers listed are for units without electric heat "OZ" models. Hot gas bypass models not available without electric heat. See Heater Replacement Parts Manual for units with electric heat.

NS = Not shown

BLOWER ASSEMBLY

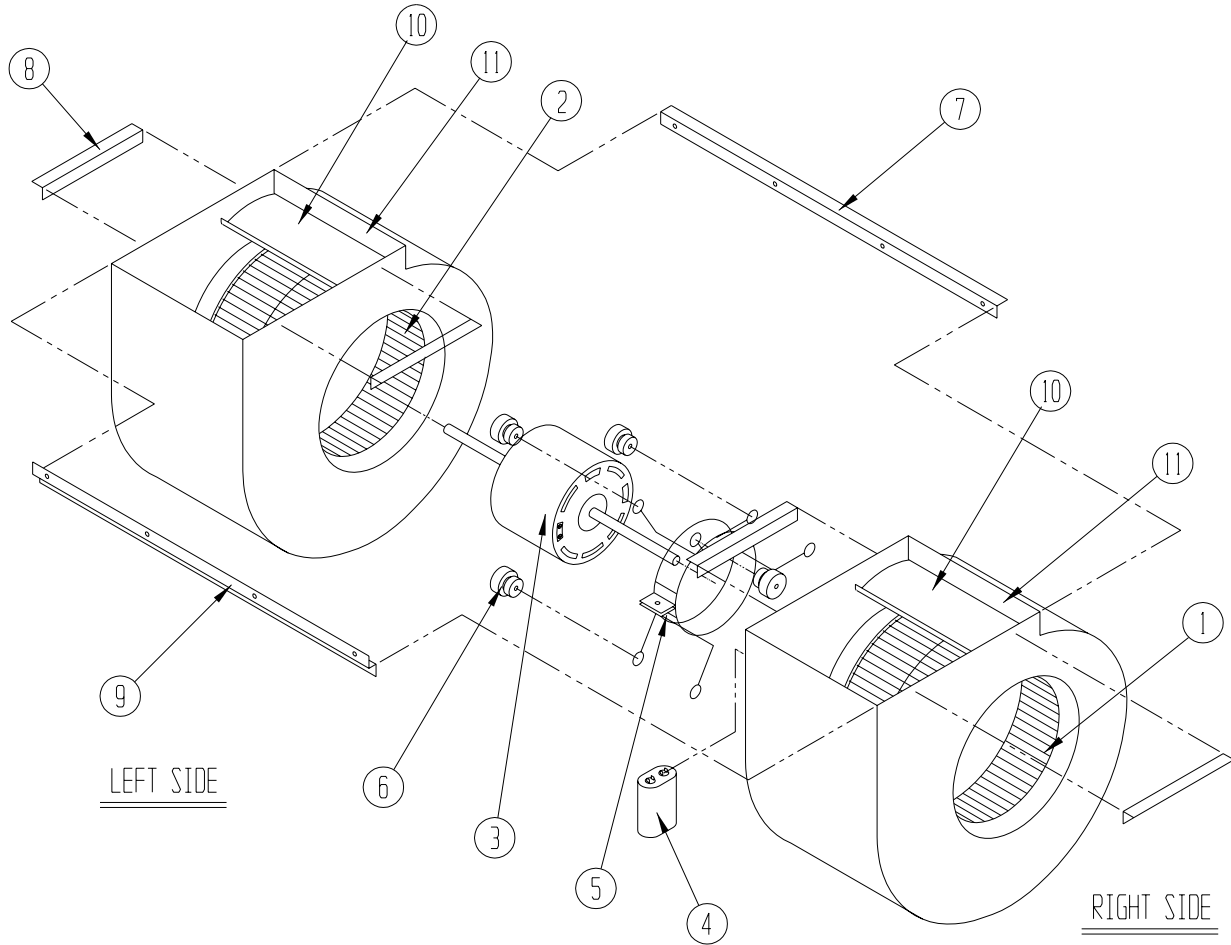

SEXP-178

Drawing No.	Part No.	Description	900-183	900-184	900-185	900-186
1	5152-011	10 Inch Wheel (CW)			X	X
1	5152-057	9 Inch Wheel (CW)	X	X		
2	5152-012	10 Inch Wheel (CCW)			X	X
2	5152-058	9 Inch Wheel (CCW)	X	X		
3	8106-030	Blower Motor (230/208)	X		X	
3	8106-025	Blower Motor (460)		X		X
4	8552-005	Capacitor	X	X	X	X
5	8200-040	Motor Mount	X	X	X	X
6	5451-011	Grommets	6	6	6	6
7	105-881	Back Brace	X	X	X	X
8	105-880	Side Angle	4	4	4	4
9	103-389	Front Brace	X	X	X	X
10	151-101	Housing	2	2	2	2
11	144-166	Diffuser	2	2	2	2