

---

# REPLACEMENT PARTS MANUAL

# WALL MOUNTED PACKAGE AIR CONDITIONER

Models: W17L1, W18L1, W24L1

---

## General Notes

- Revised and/or additional pages may be issued from time to time.
- A complete and current manual consists of pages shown in the following contents section.

## Important

- Contact the installing and/or local Bard distributor for all parts requirements. Make sure you have the complete model and serial number available from the unit rating plates.

## Contents

Description	Page
Cabinet Components	
♦ Exploded View.....	2
♦ Usage List .....	3
Functional Components	
♦ Exploded View.....	4
♦ Usage List .....	5
Control Panel	
♦ Exploded View.....	6
♦ Usage List .....	7
Blower Assembly	
♦ Exploded View.....	8
♦ Usage List .....	8



Climate Control Solutions

Bard Manufacturing Company, Inc.  
Bryan, Ohio 43506  
*Since 1914...Moving ahead, just as planned.*

Manual: 2110-486F  
Supersedes: 2110-486E  
File: Tab 16  
Date: 06-22-11  
**REVISED: 1-18-23**

---

**1-18-23: Corrections made to pages 5 & 7**

# CABINET COMPONENTS

---

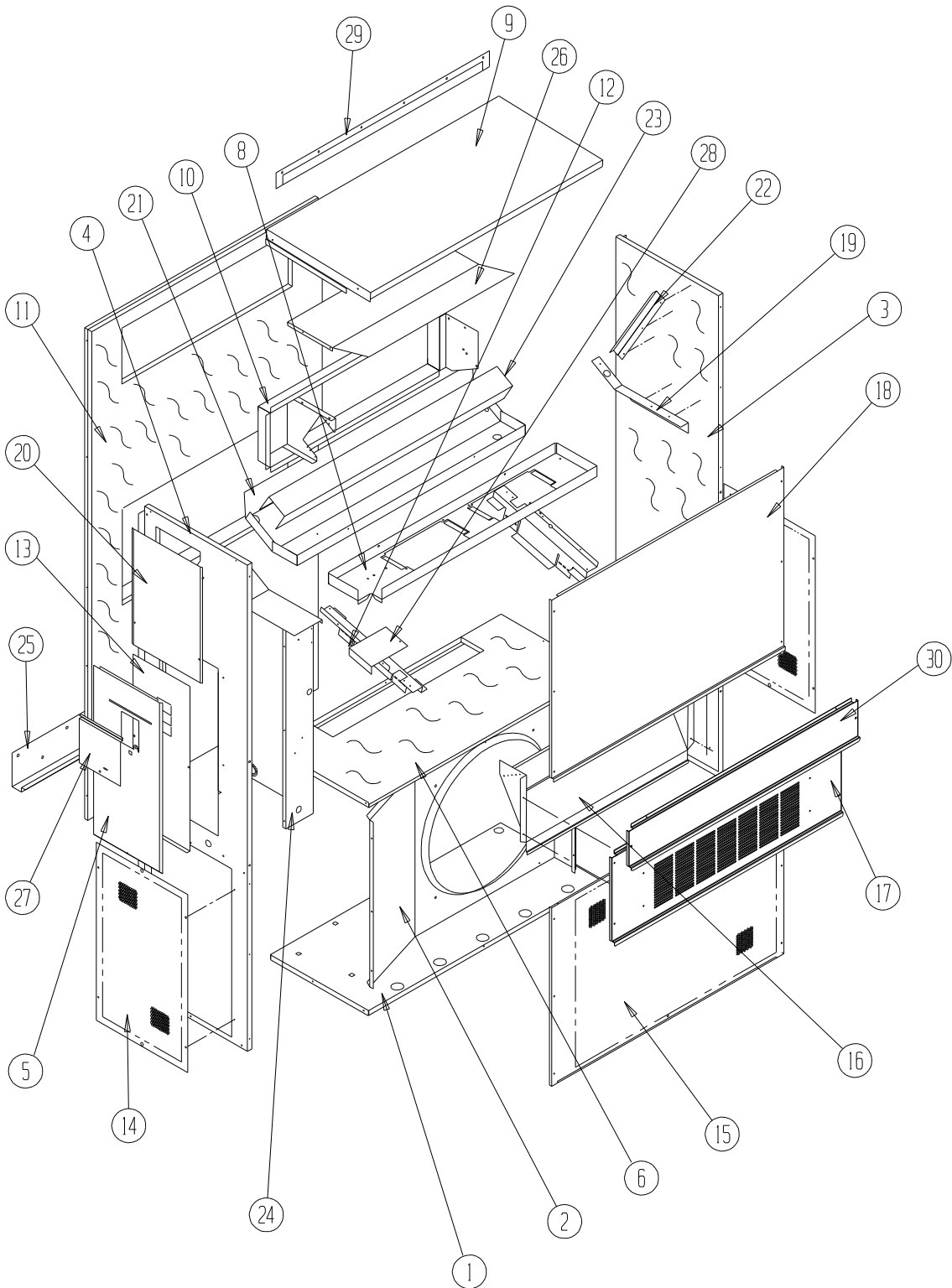

SEXP-522

# CABINET COMPONENTS

Dwg. No.	Part Number	Description	W17L1-A W18L1-A	W24L1-A, -B	W24L1-F
1	S127-204	Lower Base	X	X	X
1	S127-370 ③	Lower Base	X	X	X
2	125-023	Fan Shroud	X	X	X
2	125-056 ③	Fan Shroud	X	X	X
3	S500-317-* ①	Right Side	X	X	X
3	S500-458 ②	Right Side	X	X	X
3	S500Y527 ③	Right Side	X	X	X
4	S500-318-* ①	Left Side	X	X	X
4	S500-459 ②	Left Side	X	X	X
4	S500-529 ③	Left Side	X	X	X
5	S533-109-* ①	Control Panel Cover (Outer)	X	X	X
5	S533-184 ②	Control Panel Cover (Outer)	X	X	X
5	S533-204 ③	Control Panel Cover (Outer)	X	X	X
6	S521Y204	Condenser Partition	X	X	X
8	121Y336	Blower Partition	X	X	X
9	S506-137-* ①	Top	X	X	X
9	S506-270 ②	Top	X	X	X
9	S506-276 ③	Top	X	X	X
10	S111Y032	Outlet Air Frame Assembly	X	X	X
11	S508-097	Back	X	X	X
11	S508-208 ②	Back	X	X	X
11	S508-220 ③	Back	X	X	X
12	113Y195	Filter Bracket	2	2	2
13	S132-0104	Control Panel Cover (Inner)	X	X	X
14	118-056-* ①	Side Grille	2	2	2
14	118-060 ②	Side Grille	2	2	2
14	118-067 ③	Side Grille	2	2	2
15	118-051-* ①	Condenser Grille	X	X	X
15	118-071 ②	Condenser Grille	X	X	X
15	118-077 ③	Condenser Grille	X	X	X
16	BFAD-2	Fresh Air Damper Assembly	X	X	X
17	S552-451-* ①	Vent Option Door	X	X	X
17	S552-454 ②	Vent Option Door	X	X	X
17	S552-460 ③	Vent Option Door	X	X	X
18	S514-163-* ①	Upper Front	X	X	X
18	S514-164 ②	Upper Front	X	X	X
18	S514-167 ③	Upper Front	X	X	X
19	105Y850	Side Support	X	X	X
20	S143-034-* ①	Right Side Cover Plate (Outer)	X	X	X
20	S143-103 ②	Right Side Cover Plate (Outer)	X	X	X
20	S143-127 ③	Right Side Cover Plate (Outer)	X	X	X
21	S123-092	Drain Pan	X	X	X
22	147-044	Left Evaporator Support	X	X	X
23	137-195	Bottom Evaporator Fill	X	X	X
24	Control Panel Assembly	See Control Panel Assy. Drawing & Parts List Assy.	X	X	X
25	113-140	Bottom Mounting Bracket	X	X	X
26	135Y127	Heat Shield	X	X	X
27	S153-218-* ①	Disconnect Access Door	X	X	X
27	S153-387 ②	Disconnect Access Door	X	X	X
27	S153-405 ③	Disconnect Access Door	X	X	X
28	137-259	Fill Plate	X	X	X
29	113-141-* ①	Top Rain Flashing	X	X	X
29	113-361 ③	Top Rain Flashing	X	X	X
30	S552-452-* ①	Filter Door	X	X	X
30	S552-455 ②	Filter Door	X	X	X
30	S552-461 ③	Filter Door	X	X	X
NS	S536-176	Condenser Partition Block Off Plate	X	X	X

① Exterior cabinet parts are manufactured with various paint color options. To ensure that you receive the proper paint color, you must include the complete model and serial number of the unit for which cabinet parts are being ordered.

② Note: Exterior cabinet parts are manufactured from aluminum Code "A"

③ Note: Exterior cabinet parts are manufactured from stainless steel Code "S"

NS = Not Shown

# FUNCTIONAL COMPONENTS

---

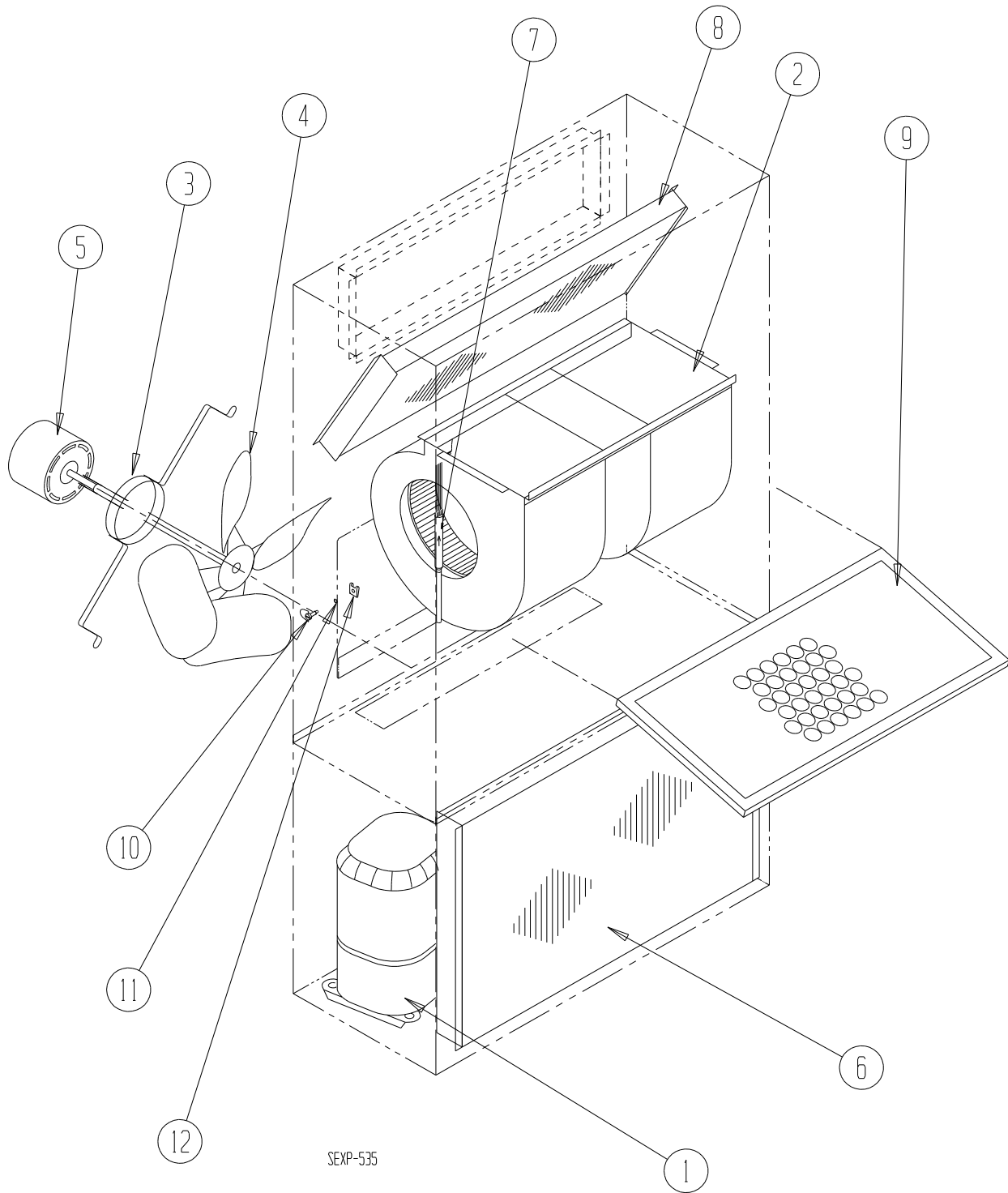

# FUNCTIONAL COMPONENTS

Dwg. No.	Part No.	Description	W17L1-A	W18L1-A	W24L1-A	W24L1-D	W24L1-B	W24L1-F
1	8000-313	Compressor	X	X				
1	8000-314	Compressor			X			
1	<del>8000-316</del>	<del>Compressor</del>				*		
1	8000-315	Compressor					X	
1	<del>8000-316</del>	Compressor						X
2	S900-248	Blower Assembly			X		X	X
2	S900-291	Blower Assembly	X	X				
3	8200-001	Fan Motor Mount	X	X	X		X	X
4	5151-033	Fan Blade	X	X	X		X	X
5	8103-016	Condensor Motor	X	X	X		X	X
6	5051-092BX	Condensor Coil	X	X				
6	5051-155BX	Condensor Coil			X		X	X
7	5651-209	TXV	X					
7	5625-104	Distributor		X				
7	5625-103	Distributor			X		X	X
7	5625-013	Distributor	X					
8	5060-066BX	Evaporator Coil	X	X	X		X	X
9	7004-011	Air Filter 1" Throw-Away	X	X	X		X	X
9	7003-032	Air Filter 1" Washable ①	X	X	X		X	X
9	7004-025	Air Filter 2" Pleated ①	X	X	X		X	X
10	1171-022	1/4" Turn Fastener	X	X	X		X	X
11	1171-024	1/4" Turn Retainer	X	X	X		X	X
12	1171-023	1/4" Receptacle	X	X	X		X	X
NS	8612-027	LAC Modulating	X					
NS	5201-001	Filter Drier	X	X	X		X	X
NS	1804-0385	High Pressure Switch (Flare)	X	X	X		X	X
NS	1804-0386	Low Pressure Switch (Flare)	X	X	X		X	X
NS	CMA-28	Low Ambient Control (Flare) ①	X	X	X		X	X

NS = Not Shown

① = Optional on these models

# CONTROL PANEL

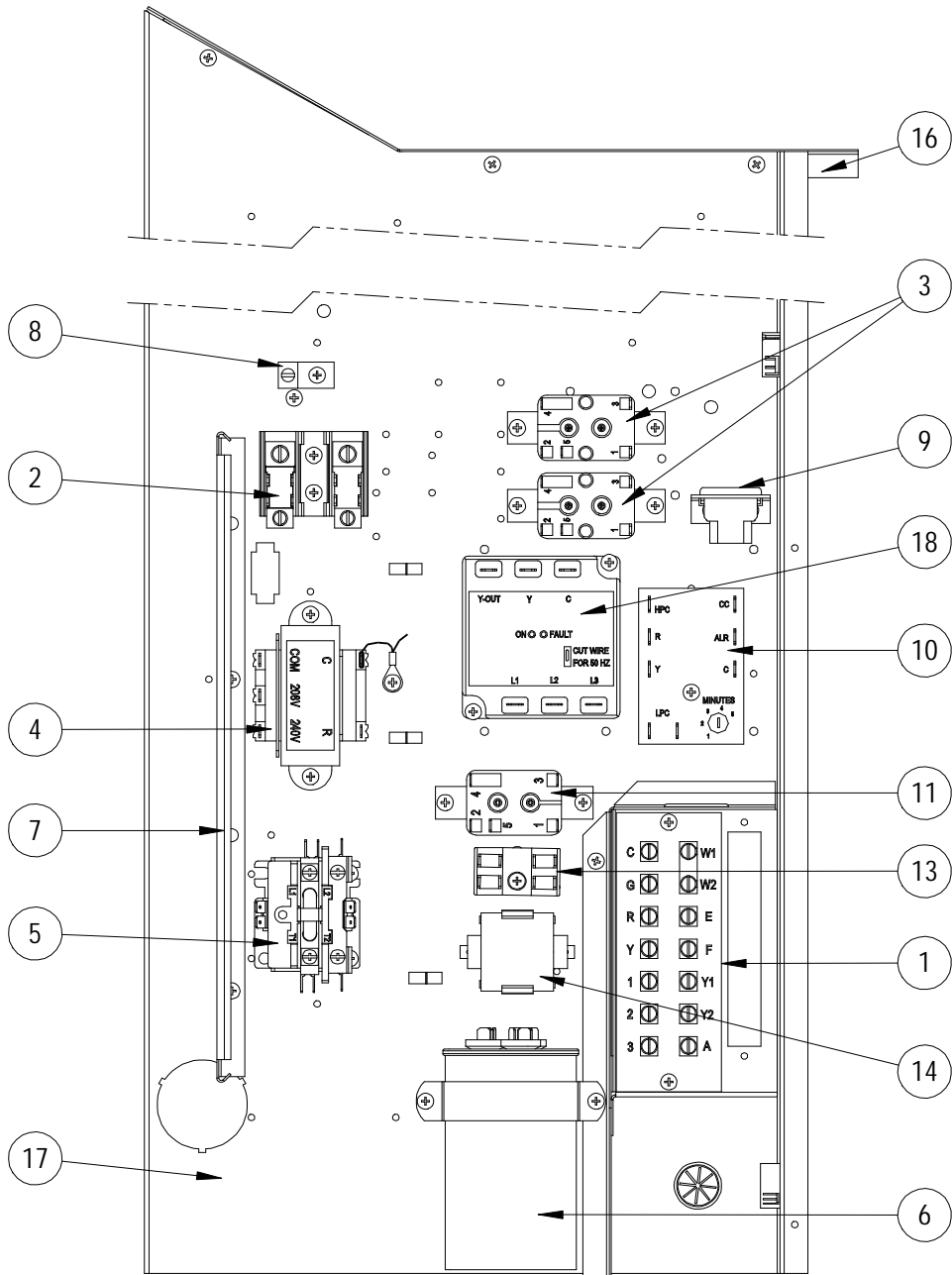

SEXP-523 A

# CONTROL PANEL

Drawing No.	Part No.	Description	W17L1-A, W18L1-A	W24L1-A, W24L1-B	W24L1-B	W24L1-F
1	8607-024	Low Voltage Terminal Strip	X	X	X	X
2	8607-013	Terminal Block 2 Pole	X	X		2
2	8607-014	Terminal Block 3 Pole			X	
3	8201-009	Blower Control Relay	2	X	X	X
4	8407-034	Transformer	X	X	X	X
5	8401-007	Compressor Contactor	X	X		
5	8401-002	Compressor Contactor			X	X
6	8552-046	Compressor Capacitor	X			
6	8552-047	Compressor Capacitor		X		
6	8552-002	Outdoor Motor Capacitor			X	X
7	135-122	Wire Shield	X	X	X	X
8	8611-006	Ground Terminal	X	X	X	X
9	3000-968	6-Pin Connector	X	X	X	X
10	8201-088	Compressor Control Module (Opt.)	X	X	X	X
11	8201-062	Alarm Relay (Optional)	X	X	X	X
13	8607-017	Terminal Block (Optional) (Shown)	X	X	X	X
14	8551-004	Start Device (PTCR) (Optional)	X	X	X	X
16	117Y137	Control Panel Top	X	X	X	X
17	117Y123	Control Panel	X	X	X	X
18	8201-085	Phase Monitor			X	X
NS	8615-035	Circuit Breaker 20A 2 Pole (Opt.) Ⓞ	X			
NS	8615-036	Circuit Breaker 25A 2 Pole (Opt.) Ⓞ		X		
NS	8615-067	Toggle Disconnect (Optional) Ⓞ				X
NS	8615-056	Circuit Breaker 15A 3 Pole (Opt.) Ⓞ			X	
NS	4095-143	Wiring Diagram	X	X		
NS	4095-243	Wiring Diagram			X	
NS	4095-632	Wiring Diagram				X

NS = Not Shown

# BLOWER ASSEMBLY

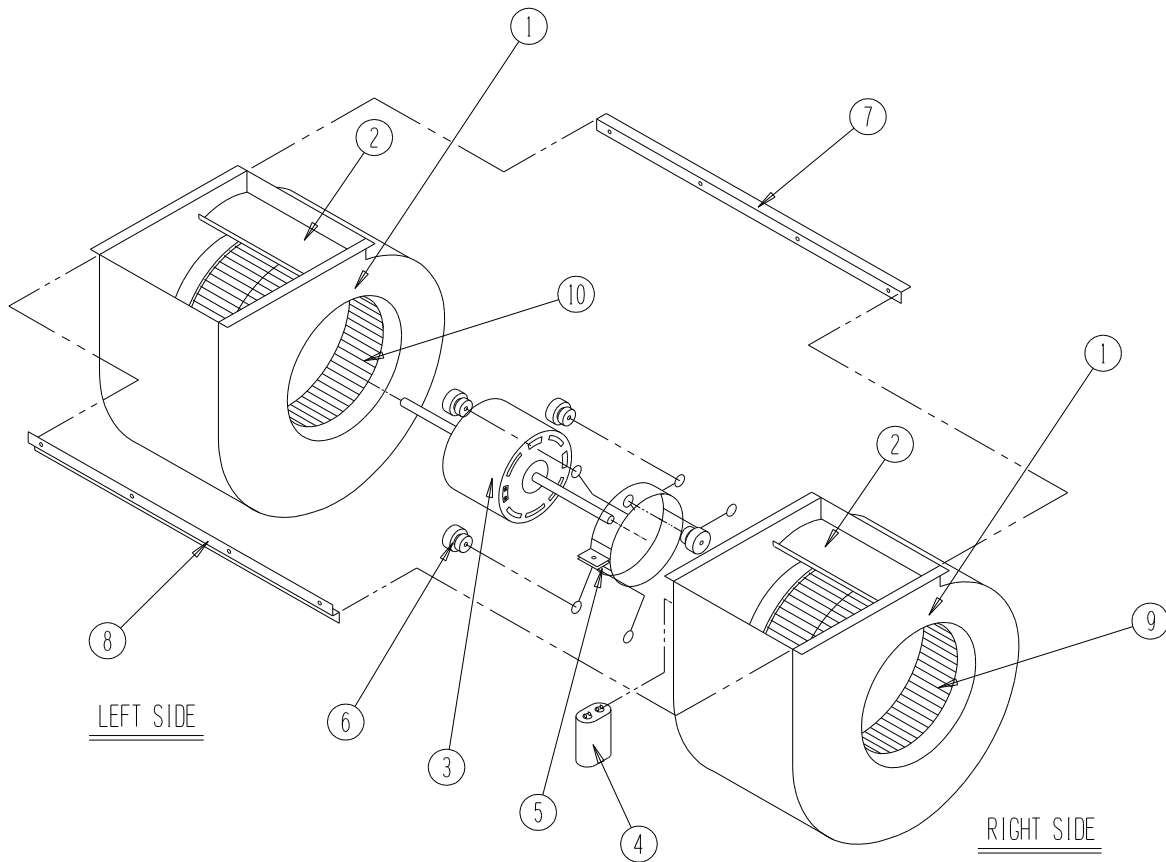

SEXP-346

Drawing No.	Part No.	Description	S900-248	S900-291
1	151-115	Housing	2	2
2	144-183	Cutoff	2	2
3	8102-011	Blower Motor (230/208)	X	
3	8102-014	Blower Motor (230/208)		X
4	8552-002	Capacitor	X	X
5	8200-031	Motor Mount	X	X
6	5451-011	Grommets	6	6
7	105-1061	Back Brace	X	X
8	103-435	Front Brace	X	X
9	5152-092	Wheel 9-6 CW	X	X
10	5152-093	Wheel 9-6 CCW	X	X