REPLACEMENT PARTS MANUAL

WALL MOUNTED PACKAGE AIR CONDITIONER

Models: **W70A13** **W70L13**

General Notes

- Revised and/or additional pages may be issued from time to time.
- A complete and current manual consists of pages shown in the following contents section.

Important

- Contact the installing and/or local Bard distributor for all parts requirements. Make sure you have the complete model and serial number available from the unit rating plates.

Contents

Description	Page
Cabinet Components	
♦ Exploded View - Right Hand	2
♦ Usage List - Right Hand	3
♦ Exploded View - Left Hand	4
♦ Usage List - Left Hand	5
Functional Components	
♦ Exploded View	6
♦ Usage List	7
Control Panel	
♦ Exploded View	8
♦ Usage List	9
Blower Assembly	
♦ Exploded View	10
♦ Usage List	10



Bard Manufacturing Company, Inc.
Bryan, Ohio 43506
Since 1914...Moving ahead, just as planned.

Manual: 2110-489
Supersedes: **NEW**
File: Tab 16
Date: 02-10-09

CABINET COMPONENTS

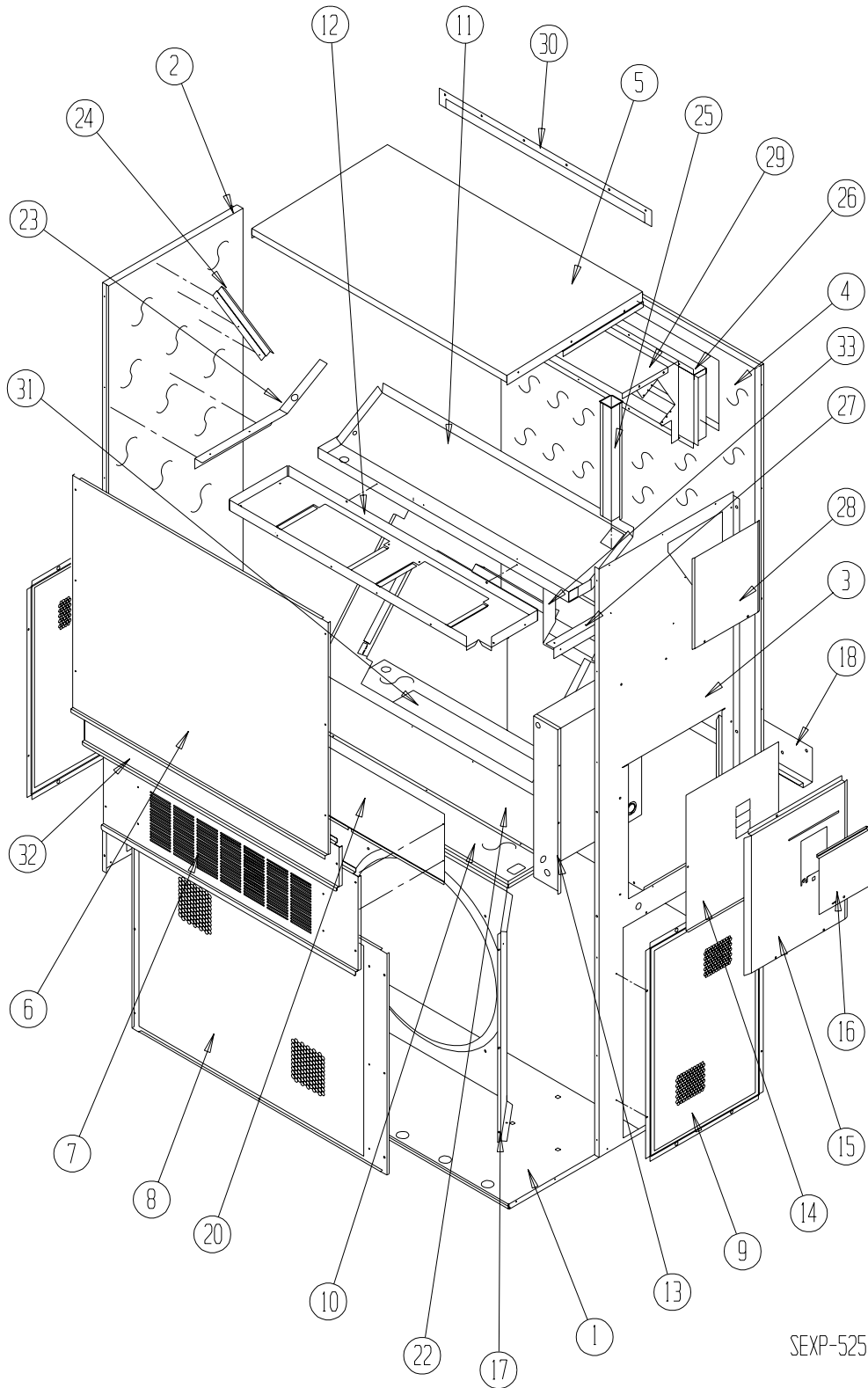

SEXP-525

This drawing is referenced in Table on Page 3

CABINET COMPONENTS

Dwg. No.	Part Number	Description	W70A13
1	S127X214	Lower Base	X
2	S500-316-* ①	Left Side	X
3	S500-315-* ①	Right Side	X
4	S508-159	Back	X
5	S506-142-* ①	Top	X
6	S515-144-* ①	Upper Front	X
7	S553-383-* ①	Vent Option Door	X
8	118-052-* ①	Condenser Grille	X
9	118-058-* ①	Side Grille	2
10	S521X333	Condenser Partition	X
11	S123-102	Drain Pan	X
12	121X216	Blower Partition	X
13	Control Panel Assembly	See Control Panel Assembly Drawing and Parts List	X
14	S132-114	Control Panel Cover (Inner)	X
15	S533-113-* ①	Control Panel Cover (Outer)	X
16	S153-218-* ①	Disconnect Access Door	X
17	125-029	Fan Shroud	X
18	113-140	Bottom Mounting Bracket	X
20	BOP-5	Blank Off Plate	X
22	NOT USED	Filter Tray	
23	105X877	Left Side Support	X
24	147-046	Left Evaporator Support	X
25	135-128	Raceway	X
26	S111X030	Outlet Air Frame Assembly	X
27	105X878	Right Side Support	X
28	S143-042-* ①	Right Side Cover Plate (Outer)	X
29	135X123	Heat Shield	X
30	113-150-* ①	Top Rain Flashing	X
31	S536-258	Cond. Partition Block Off Plate	X
32	S553-384-* ①	Filter Door Assembly	X
33	NOT USED	Inlet Airframe	

① Exterior cabinet parts are manufactured with various paint color options. To insure that you receive the proper paint color, you must include the complete model and serial number of the unit for which cabinet parts are being ordered.

This Table is references drawing on Page 2

CABINET COMPONENTS

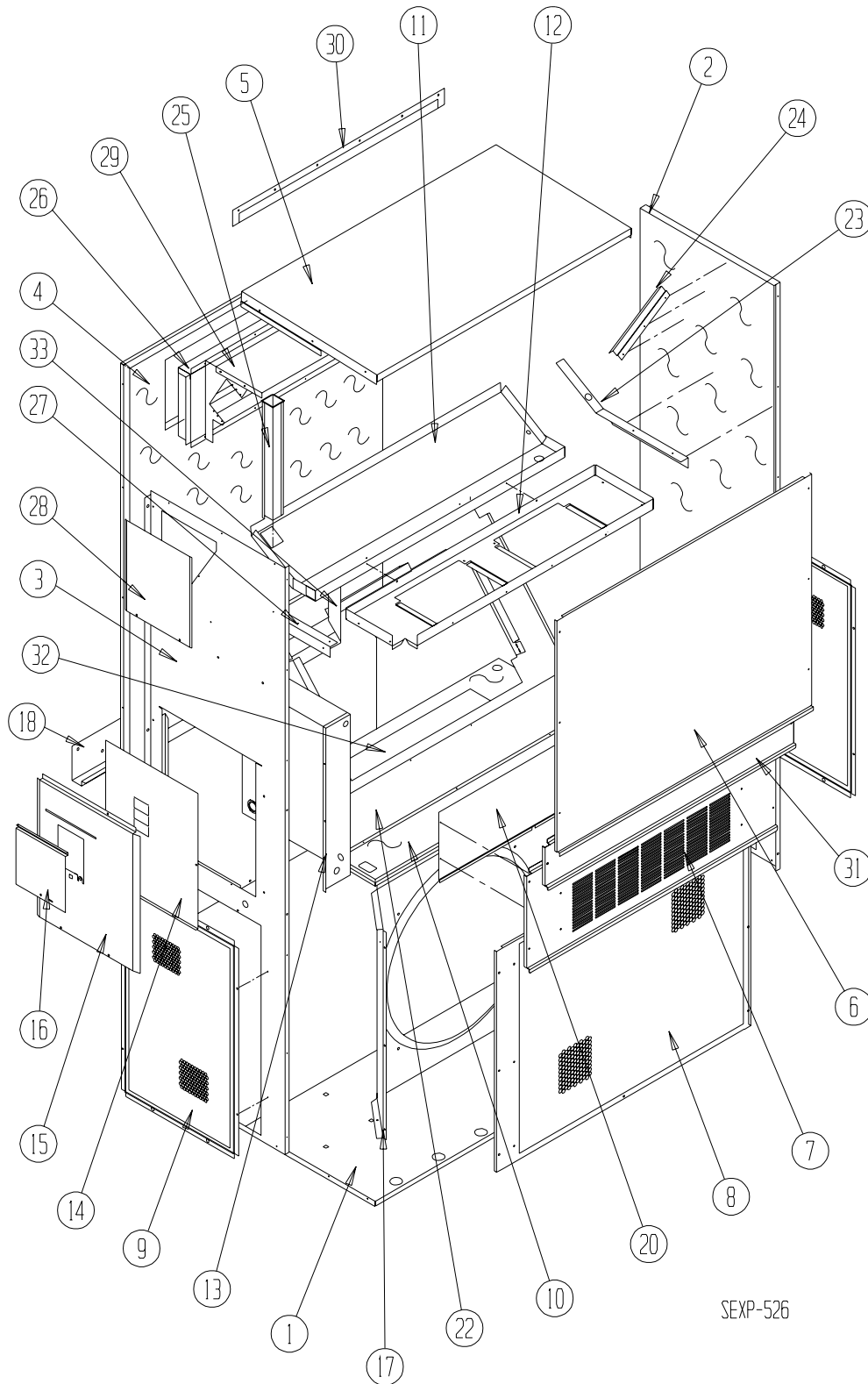

SEXP-526

This drawing is referenced in Table on Page 5

CABINET COMPONENTS

Drawing No.	Part No.	Description	W70L13
1	S127Y214	Lower Base	X
2	S500-367-* ①	Right Side	X
3	S500-368-* ①	Left Side	X
4	S508-159	Back	X
5	S506-142-* ①	Top	X
6	S515-144-* ①	Upper Front	X
7	S552-383-* ①	Vent Option Door	X
8	118-052-*①	Condenser Grille	X
9	118-058-*①	Side Grille	2
10	S521Y333	Condenser Partition	X
11	S123-091	Drain Pan	X
12	121Y216	Blower Partition	X
13	Control Panel Assembly	See Control Panel Assembly Drawing & Parts List	X
14	S132-114	Control Panel Cover (Inner)	X
15	S533-140-* ①	Control Panel Cover (Outer)	X
16	S153-218-* ①	Disconnect Access Door	X
17	125-029	Fan Shroud	X
18	113-140	Bottom Mounting Bracket	X
20	BOP-5	Blank Off Plate	X
22	NOT USED	Filter Tray	
23	105Y877	Left Side Support	X
24	147-046	Left Evaporator Support	X
25	135-128	Raceway	2
26	S111Y030	Outlet Air Frame Assembly	X
27	105Y878	Right Side Support	X
28	S143-042-* ①	Right Side Cover Plate (Outer)	X
29	135Y123	Heat Shield	X
30	113-150-*①	Top Rain Flashing	X
31	S553-384-* ①	Filter Door Assembly	X
32	S536-498	Condenser Partition Block Off Plate	X
33	NOT USED	Inlet Airframe	

① Exterior cabinet parts are manufactured with various paint color options. To insure that you receive the proper paint color, you must include the complete model and serial number of the unit for which cabinet parts are being ordered.

This Table is references drawing on Page 4

FUNCTIONAL COMPONENTS

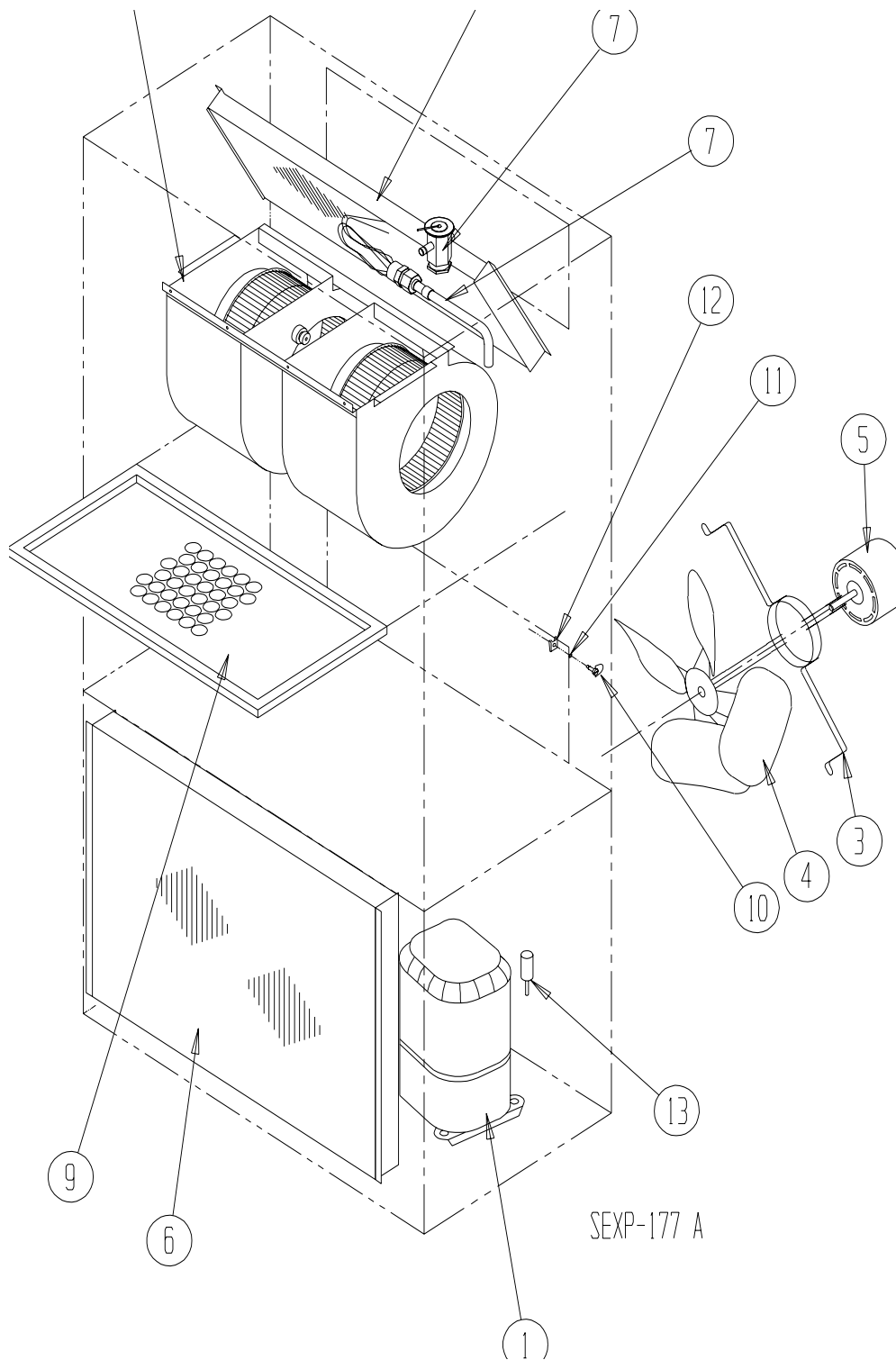

This Exploded View references Table on Page 7

FUNCTIONAL COMPONENTS

Dwg. No.	Part Number	Description	W70A13	W70L13
1	8000-337	Compressor	X	X
2	S900-185	Blower Assembly	X	X
3	8200-004	Fan Motor Mount	X	X
4	5151-030	Fan Blade	X	X
5	8106-016	Condenser Motor	X	X
6	5051-088BX	Condenser Coil	X	X
7	800-0395	Distributor Assembly	X	X
7	5651-189	TXV	X	X
8	5060-082BX	Evaporator Coil	X	X
9	NOT USED	Air Filter		
10	1171-022	1/4 Turn Fastener	X	X
11	1171-024	1/4 Turn Retainer	X	X
12	1171-023	1/4 Receptacle		X
NS	5201-002	Filter Drier	X	X
NS	1804-0385	High Pressure Switch (Flare)	X	X
NS	1804-0386	Low Pressure Switch (Flare)	X	X
NS	CMA-28	Low Ambient Control (Flare) ①	X	X

NS – Not Shown

① – Optional on these models

This Table references Exploded View on Page 6

CONTROL PANEL

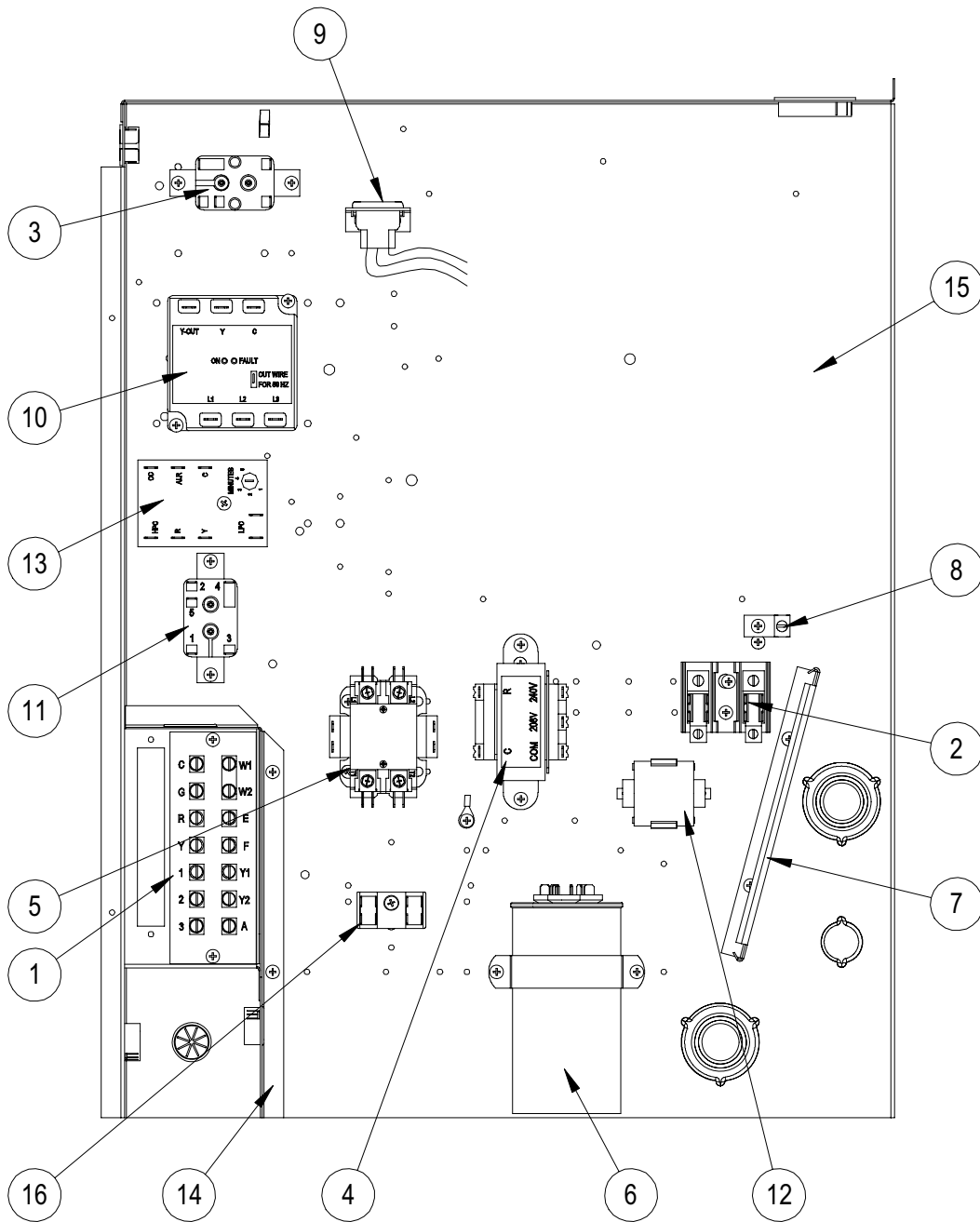

SEXP-512

This drawing is referenced in Tables on Page 9

CONTROL PANEL

Drawing No.	Part No.	Description	W70A13	W70L13
1	8607-024	Low Voltage Terminal Strip	X	X
2	8607-013	Terminal Block 2 Pole	X	X
3	8201-009	Blower Control Relay	X	X
4	8407-034	Transformer	X	X
5	8401-025	Compressor Contactor	X	X
6	8552-082	Compressor Capacitor	X	X
7	135-130	Wire Shield	X	X
8	8611-006	Ground Terminal	X	X
9	3000-1277	6 Pin Connector	X	X
11	8201-062	Alarm Relay ①	X	X
12	8551-004	Start Device (PTCR)	X	X
13	8201-088	Compressor Control Module	X	X
14	117X139	Low Voltage Box	X	
14	117Y139	Low Voltage Box		X
15	117X143	Control Panel	X	
15	117Y143	Control Panel		X
16	8607-017	Terminal Block ①	X	X
NS	8615-041	Circuit Breaker 60A 2 Pole ②	X	X
NS	4095-151	Wiring Diagram	X	X

① Optional on these models.

② Circuit breakers listed are for units without electric heat "0Z" models. Hot gas bypass models not available without electric heat. See Heater Replacement Parts Manual for units with electric heat.

NS = Not shown

This Table is references drawing on Page 8

BLOWER ASSEMBLY

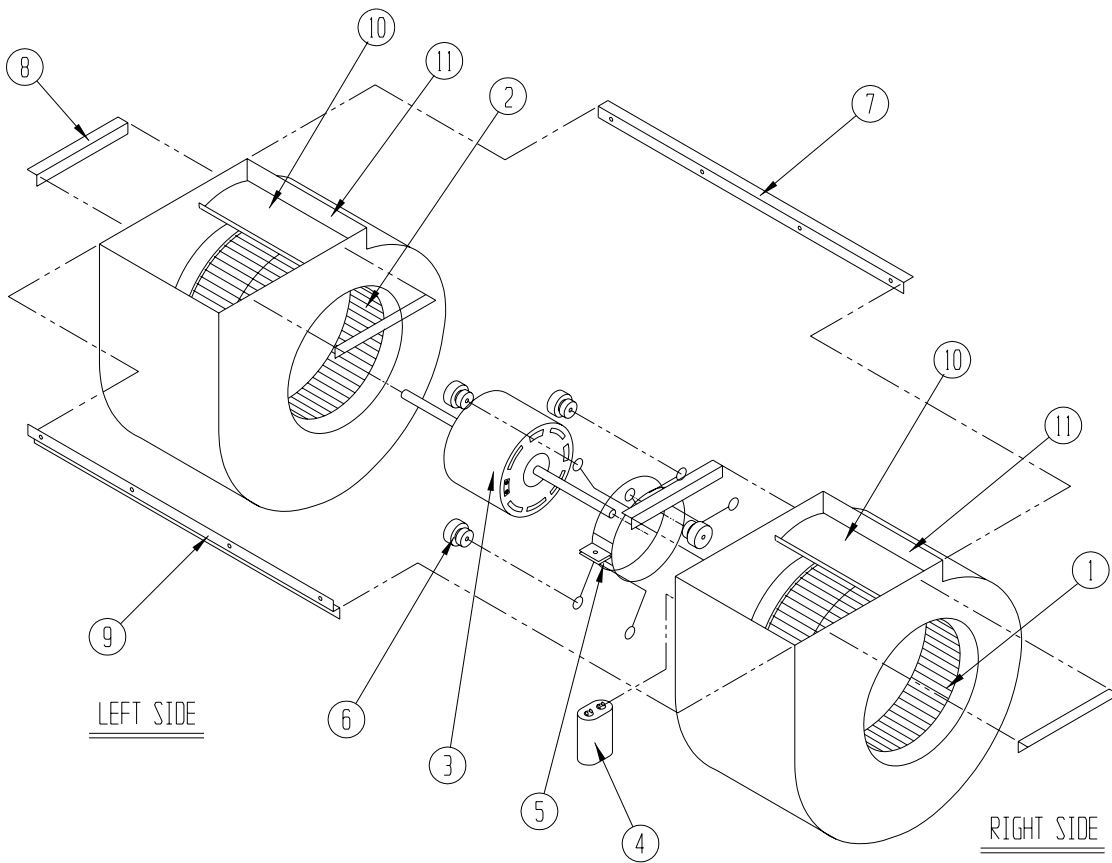

SEXP-178

Drawing No.	Part No.	Description	900-185
1	5152-011	10 Inch Wheel (CW)	X
2	5152-012	10 Inch Wheel (CCW)	X
3	8106-046	Blower Motor (230/208)	X
4	8552-091	Capacitor	X
5	8200-040	Motor Mount	X
6	5451-011	Grommets	6
7	105-881	Back Brace	X
8	105-880	Side Angle	4
9	103-389	Front Brace	X
10	151-101	Housing	2
11	144-166	Diffuser	2