

---

# REPLACEMENT PARTS MANUAL

---

## WALL-MOUNTED PACKAGED AIR CONDITIONER

Models:

WA3S3-A WA4S3-A WA5S3-A WL3S2-A WL4S2-A WL5S2-A  
WA3S3-B WA4S3-B WA5S3-B WL3S2-B WL4S2-B WL5S2-B  
WA3S3-C WA4S3-C WA5S3-C WL3S2-C WL4S2-C WL5S2-C

---

### General Notes

- Revised and/or additional pages may be issued from time to time.
- A complete and current manual consists of pages shown in the following contents section.

### Important

- Contact the installing and/or local Bard distributor for all parts requirements. Make sure to have the complete model and serial number available from the unit rating plates.

### Contents

Description	Page
Cabinet Components – Right Hand	
♦ Exploded View .....	2
♦ Usage List (WA3S3) .....	3
♦ Usage List (WA4S3 & WA5S3) .....	4
Cabinet Components – Left Hand	
♦ Exploded View .....	5
♦ Usage List (WL3S2) .....	6
♦ Usage List (WL4S2 & WL5S2).....	7
Functional Components – RH (shown)/LH (mirrored)	
♦ Exploded View .....	8
♦ Usage List (Right Hand).....	9
♦ Usage List (Left Hand).....	10
Control Panel – RH (shown)/LH (mirrored)	
♦ Exploded View .....	11
♦ Usage List (Right Hand).....	12
♦ Usage List (Left Hand).....	13
Blower Assembly – Right & Left Hand	
♦ Exploded View .....	14
♦ Usage List .....	14



Climate Control Solutions

Bard Manufacturing Company, Inc.  
Bryan, Ohio 43506  
www.bardhvac.com

Manual: 2110-493N  
Supersedes: 2110-493M  
Date: 10-15-18

# CABINET COMPONENTS - RIGHT HAND

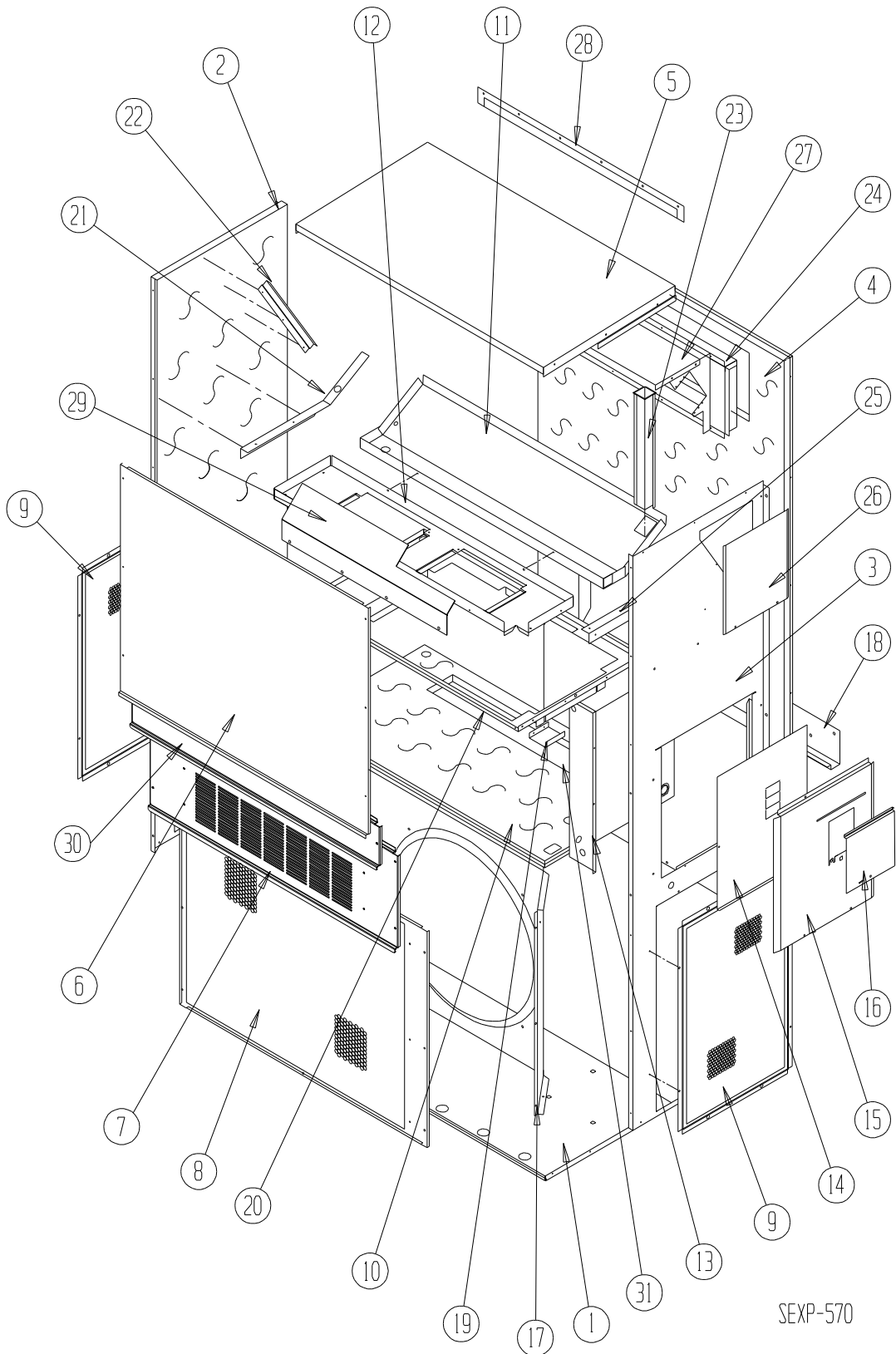

SEXP-570

## CABINET COMPONENTS – RIGHT HAND (WA3S3)

Drawing No.	Part No.	Description	WA3S3-A	WA3S3-B	WA3S3-C
1	S127-342-4	Lower Base	X	X	X
1	S127X405 ③	Lower Base	X	X	X
2	S500-262-* ①	Left Side	X	X	X
2	S500-464 ②	Left Side	X	X	X
2	S500-518 ③	Left Side	X	X	X
3	S500-261-* ①	Right Side	X	X	X
3	S500-463 ②	Right Side	X	X	X
3	S500-517 ③	Right Side	X	X	X
4	S508-098	Back	X	X	X
4	S508-191 ②	Back	X	X	X
4	S508-221 ③	Back	X	X	X
5	S506-142-* ①	Top	X	X	X
5	S506-251 ②	Top	X	X	X
5	S506-274 ③	Top	X	X	X
6	S515-144-* ①	Upper Front	X	X	X
6	S515-142 ②	Upper Front	X	X	X
6	S515-162 ③	Upper Front	X	X	X
7	S553-383-* ①	Vent Option Door	X	X	X
7	S553-408-* ①	Vent Option Door with ERV	X	X	X
7	S552-456 ②	Vent Option Door	X	X	X
7	S553-449 ③	Vent Option Door	X	X	X
8	118-048-* ①	Condenser Grille	X	X	X
8	118-064 ②	Condenser Grille	X	X	X
8	118-072 ③	Condenser Grille	X	X	X
9	118-057-* ①	Side Grille	2	2	2
9	118-063 ②	Side Grille	2	2	2
9	118-073 ③	Side Grille	2	2	2
10	S521X258	Condenser Partition	X	X	X
11	S523-125	Drain Pan Assembly	X	X	X
12	121X216	Blower Partition	X	X	X
13	Control Panel Assy.	See Control Panel Assembly Drawing and Parts List	X	X	X
14	S132-114	Control Panel Cover (Inner)	X	X	
14	S132-183	Control Panel Cover (Inner)			X
15	S533-113-* ①	Control Panel Cover (Outer)	X	X	X
15	S533-185 ②	Control Panel Cover (Outer)	X	X	X
15	S533-195 ③	Control Panel Cover (Outer)	X	X	X
16	S153-218-* ①	Disconnect Access Door	X	X	X
16	S153-387 ②	Disconnect Access Door	X	X	X
16	S153-405 ③	Disconnect Access Door	X	X	X
17	125-051	Fan Shroud	X	X	X
17	125-061 ③	Fan Shroud	X	X	X
18	113-140	Bottom Mounting Bracket	X	X	X
19	137-209	Fill	X	X	X
20	131X099	Filter Tray	X	X	X
21	105X877	Left Side Support	X	X	X
22	147-046	Left Evaporator Support	X	X	X
23	135-128	Raceway	2	2	2
24	S111X034	Outlet Air Frame Assembly	X	X	X
25	105X878	Right Side Support	X	X	X
26	S143-042-* ①	Right Side Cover Plate (Outer)	X	X	X
26	S143-105 ②	Right Side Cover Plate (Outer)	X	X	X
26	S143-125 ③	Right Side Cover Plate (Outer)	X	X	X
27	135-129	Heat Shield	X	X	X
28	113-150-* ①	Top Rain Flashing	X	X	X
28	113-359 ②	Top Rain Flashing	X	X	X
29	135-175	Air Deflector	X	X	X
30	S553-384-* ①	Filter Door Assembly	X	X	X
30	S552-457 ②	Filter Door Assembly	X	X	X
30	S553-450 ③	Filter Door Assembly	X	X	X
31	S536-258	Condenser Partition Blank-Off Plate	X	X	X

① Exterior cabinet parts are manufactured with various paint color options. To ensure the proper paint color is received, include the complete model and serial number of the unit for which cabinet parts are being ordered.

② Exterior cabinet parts are manufactured from aluminum Code "A"

③ Exterior cabinet parts are manufactured from stainless steel Code "S"

# CABINET COMPONENTS – RIGHT HAND (WA4S3 & WA5S3)

Drawing No.	Part No.	Description	WA4S3-A	WA4S3-B	WA4S3-C	WA5S3-A	WA5S3-B	WA5S3-C
1	S127-342-4	Lower Base	X	X	X	X	X	X
1	S127X405 ③	Lower Base	X	X	X	X	X	X
2	S500-316-* ①	Left Side	X	X	X	X	X	X
2	S500-545 ②	Left Side	X	X	X	X	X	X
2	S500-543 ③	Left Side	X	X	X	X	X	X
3	S500-315-* ①	Right Side	X	X	X	X	X	X
3	S500-546 ②	Right Side	X	X	X	X	X	X
3	S500-544 ③	Right Side	X	X	X	X	X	X
4	S508-129	Back	X	X	X	X	X	X
4	S508-229 ②	Back	X	X	X	X	X	X
4	S508-228 ③	Back	X	X	X	X	X	X
5	S506-142-* ①	Top	X	X	X	X	X	X
5	S506-251 ②	Top	X	X	X	X	X	X
5	S506-274 ③	Top	X	X	X	X	X	X
6	S515-144-* ①	Upper Front	X	X	X	X	X	X
6	S514-142 ②	Upper Front	X	X	X	X	X	X
6	S514-162 ③	Upper Front	X	X	X	X	X	X
7	S553-383-* ①	Vent Option Door	X	X	X	X	X	X
7	S553-408-* ①	Vent Option Door with ERV	X	X	X	X	X	X
7	S552-456 ②	Vent Option Door	X	X	X	X	X	X
7	S553-449 ③	Vent Option Door	X	X	X	X	X	X
8	118-052-* ①	Condenser Grille	X	X	X	X	X	X
8	118-080 ②	Condenser Grille	X	X	X	X	X	X
8	118-078 ③	Condenser Grille	X	X	X	X	X	X
9	118-058-* ①	Side Grille	2	2	2	2	2	2
9	118-081 ②	Side Grille	2	2	2	2	2	2
9	118-079 ③	Side Grille	2	2	2	2	2	2
10	S521X258	Condenser Partition	X	X	X	X	X	X
11	S523-125	Drain Pan Assembly	X	X	X	X	X	X
12	121X216	Blower Partition	X	X	X	X	X	X
13	Control Panel Assy.	See Control Panel Assembly Drawing and Parts List	X	X	X	X	X	X
14	S132-114	Control Panel Cover (Inner)	X	X		X	X	
14	S132-183	Control Panel Cover (Inner)			X			X
15	S533-113-* ①	Control Panel Cover (Outer)	X	X	X	X	X	X
15	S533-185 ②	Control Panel Cover (Outer)	X	X	X	X	X	X
15	S533-195 ③	Control Panel Cover (Outer)	X	X	X	X	X	X
16	S153-218-* ①	Disconnect Access Door	X	X	X	X	X	X
16	S153-387 ②	Disconnect Access Door	X	X	X	X	X	X
16	S153-405 ③	Disconnect Access Door	X	X	X	X	X	X
17	125-050	Fan Shroud	X	X	X	X	X	X
17	125-062 ③	Fan Shroud	X	X	X	X	X	X
18	113-140	Bottom Mounting Bracket	X	X	X	X	X	X
19	137-209	Fill	X	X	X	X	X	X
20	131X099	Filter Tray	X	X	X	X	X	X
21	105X877	Left Side Support	X	X	X	X	X	X
22	147-046	Left Evaporator Support	X	X	X	X	X	X
23	135-128	Raceway	2	2	2	2	2	2
24	S111X034	Outlet Air Frame Assembly	X	X	X	X	X	X
25	105X878	Right Side Support	X	X	X	X	X	X
26	S143-042-* ①	Right Side Cover Plate (Outer)	X	X	X	X	X	X
26	S143-105 ②	Right Side Cover Plate (Outer)	X	X	X	X	X	X
26	S143-125 ③	Right Side Cover Plate (Outer)	X	X	X	X	X	X
27	135-129	Heat Shield	X	X	X	X	X	X
28	113-150-* ①	Top Rain Flashing	X	X	X	X	X	X
28	113-359 ②	Top Rain Flashing	X	X	X	X	X	X
30	S553-384-* ①	Filter Door Assembly	X	X	X	X	X	X
30	S552-457 ②	Filter Door Assembly	X	X	X	X	X	X
30	S553-450 ③	Filter Door Assembly	X	X	X	X	X	X
31	S536-258	Condenser Partition Blank-Off Plate	X	X	X	X	X	X

① Exterior cabinet parts are manufactured with various paint color options. To ensure the proper paint color is received, include the complete model and serial number of the unit for which cabinet parts are being ordered.

② Exterior cabinet parts are manufactured from aluminum Code "A"

③ Exterior cabinet parts are manufactured from stainless steel Code "S"

# CABINET COMPONENTS - LEFT HAND

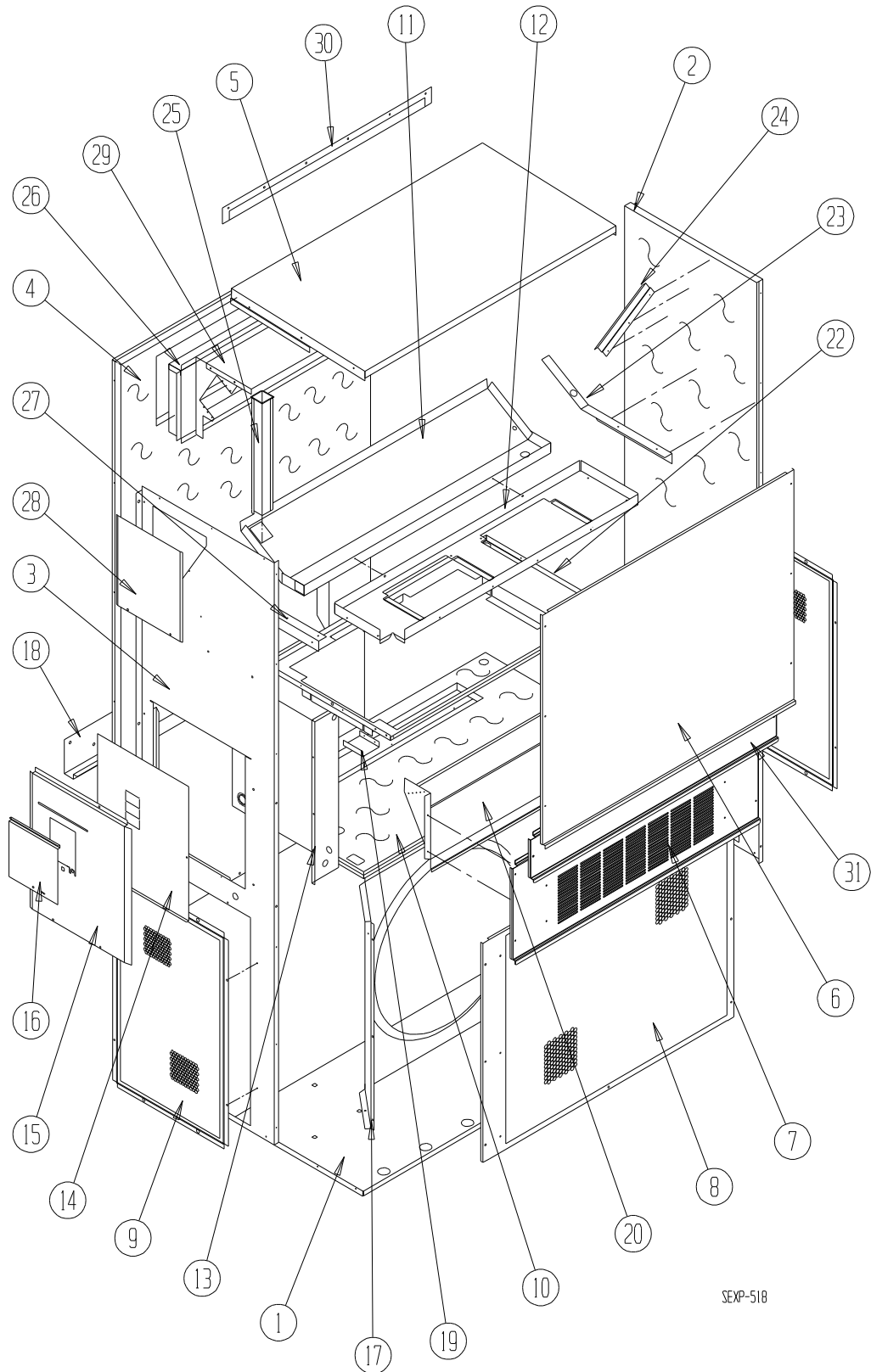

SEXP-518

# CABINET COMPONENTS – LEFT HAND (WL3S2)

Drawing No.	Part No.	Description	WL3S2-A	WL3S2-B	WL3S2-C
1	S127-403-4	Lower Base	X	X	X
1	S127X405 ③	Lower Base	X	X	X
2	S500-319-* ①	Right Side	X	X	X
2	S500-465 ②	Right Side	X	X	X
2	S500-516 ③	Right Side	X	X	X
3	S500-320-* ①	Left Side	X	X	X
3	S500-466 ②	Left Side	X	X	X
3	S500-519 ③	Left Side	X	X	X
4	S508-098	Back	X	X	X
4	S508-191 ②	Back	X	X	X
4	S508-221 ③	Back	X	X	X
5	S506-142-* ①	Top	X	X	X
5	S506-251 ②	Top	X	X	X
5	S506-274 ③	Top	X	X	X
6	S515-144-* ①	Upper Front	X	X	X
6	S514-142 ②	Upper Front	X	X	X
6	S514-162 ③	Upper Front	X	X	X
7	S553-383-* ①	Vent Option Door	X	X	X
7	S552-456 ②	Vent Option Door	X	X	X
7	S553-449 ③	Vent Option Door	X	X	X
8	118-049-* ①	Condenser Grille	X	X	X
8	118-065 ②	Condenser Grille	X	X	X
8	118-074 ③	Condenser Grille	X	X	X
9	118-057-* ①	Side Grille	2	2	2
9	118-063 ②	Side Grille	2	2	2
9	118-073 ③	Side Grille	2	2	2
10	S521Y258	Condenser Partition	X	X	X
11	S523-137	Drain Pan Assembly	X	X	X
12	121Y216	Blower Partition	X	X	X
13	Control Panel Assy.	See Control Panel Assembly Drawing and Parts List	X	X	X
14	S132-114	Control Panel Cover (Inner)	X	X	
14	S132-306	Control Panel Cover (Inner)			X
15	S533-140-* ①	Control Panel Cover (Outer)	X	X	X
15	S533-186 ②	Control Panel Cover (Outer)	X	X	X
15	S533-203 ③	Control Panel Cover (Outer)	X	X	X
16	S153-218-* ①	Disconnect Access Door	X	X	X
16	S153-387 ②	Disconnect Access Door	X	X	X
16	S153-405 ③	Disconnect Access Door	X	X	X
17	125-051	Fan Shroud	X	X	X
17	125-061 ③	Fan Shroud	X	X	X
18	113-140	Bottom Mounting Bracket	X	X	X
19	137-209	Fill	X	X	X
20	BFAD-5	Fresh Air Damper Assembly	X	X	X
22	131Y099	Filter Tray	X	X	X
23	105Y877	Left Side Support	X	X	X
24	147-046	Left Evaporator Support	X	X	X
25	135-128	Raceway	2	2	2
26	S111Y034	Outlet Air Frame Assembly	X	X	X
27	105Y877	Right Side Support	X	X	X
28	S143-042-* ①	Right Side Cover Plate (Outer)	X	X	X
28	S143-105 ②	Right Side Cover Plate (Outer)	X	X	X
28	S143-125 ③	Right Side Cover Plate (Outer)	X	X	X
29	135-129	Heat Shield	X	X	X
30	113-150-* ①	Top Rain Flashing	X	X	X
30	113-359 ③	Top Rain Flashing	X	X	X
31	S553-384-* ①	Filter Door Assembly	X	X	X
31	S552-457 ②	Filter Door Assembly	X	X	X
31	S553-450 ③	Filter Door Assembly	X	X	X
NS	S536-498	Condenser Partition Blank-Off Plate	X	X	X

① Exterior cabinet parts are manufactured with various paint color options. To ensure the proper paint color is received, include the complete model and serial number of the unit for which cabinet parts are being ordered.

② Exterior cabinet parts are manufactured from aluminum Code "A"

③ Exterior cabinet parts are manufactured from stainless steel Code "S"

NS = Not Shown

## CABINET COMPONENTS – LEFT HAND (WL4S2 & WL5S2)

Drawing No.	Part No.	Description	WL4S2-A	WL4S2-B	WL4S2-C	WL5S2-A	WL5S2-B	WL5S2-C
1	S127-403-4	Lower Base	X	X	X	X	X	X
1	S127Y405 ③	Lower Base	X	X	X	X	X	X
2	S500-367* ①	Right Side	X	X	X	X	X	X
2	S500-547 ②	Right Side	X	X	X	X	X	X
2	S500-681 ③	Right Side	X	X	X	X	X	X
3	S500-368-* ①	Left Side	X	X	X	X	X	X
3	S500-548 ②	Left Side	X	X	X	X	X	X
3	S500-682 ③	Left Side	X	X	X	X	X	X
4	S508-129 ①	Back	X	X	X	X	X	X
4	S508-229 ②	Back	X	X	X	X	X	X
4	S508-228 ③	Back	X	X	X	X	X	X
5	S506-142-* ①	Top	X	X	X	X	X	X
5	S506-251 ②	Top	X	X	X	X	X	X
5	S506-274 ③	Top	X	X	X	X	X	X
6	S515-144-* ①	Upper Front	X	X	X	X	X	X
6	S514-142 ②	Upper Front	X	X	X	X	X	X
6	S514-162 ③	Upper Front	X	X	X	X	X	X
7	S553-383-* ①	Vent Option Door	X	X	X	X	X	X
7	S552-456 ②	Vent Option Door	X	X	X	X	X	X
7	S553-449 ③	Vent Option Door	X	X	X	X	X	X
8	118-053-* ①	Condenser Grille	X	X	X	X	X	X
8	118-082 ②	Condenser Grille	X	X	X	X	X	X
8	118-091 ③	Condenser Grille	X	X	X	X	X	X
9	118-058-* ①	Side Grille	2	2	2	2	2	2
9	118-081 ②	Side Grille	2	2	2	2	2	2
9	118-079 ③	Side Grille	2	2	2	2	2	2
10	S521Y258	Condenser Partition	X	X	X	X	X	X
11	S523-137	Drain Pan Assembly	X	X	X	X	X	X
12	121Y216	Blower Partition	X	X	X	X	X	X
13	Control Panel Assy.	See Control Panel Assembly Drawing and Parts List	X	X	X	X	X	X
14	S132-114	Control Panel Cover (Inner)	X	X		X	X	
14	S132-306	Control Panel Cover (Inner)			X			X
15	S533-140-* ①	Control Panel Cover (Outer)	X	X	X	X	X	X
15	S533-186 ②	Control Panel Cover (Outer)	X	X	X	X	X	X
15	S533-203 ③	Control Panel Cover (Outer)	X	X	X	X	X	X
16	S153-218-* ①	Disconnect Access Door	X	X	X	X	X	X
16	S153-387 ②	Disconnect Access Door	X	X	X	X	X	X
16	S153-405 ③	Disconnect Access Door	X	X	X	X	X	X
17	125-050	Fan Shroud	X	X	X	X	X	X
17	125-062 ③	Fan Shroud	X	X	X	X	X	X
18	113-140	Bottom Mounting Bracket	X	X	X	X	X	X
19	137-209	Fill	X	X	X	X	X	X
20	BFAD-5	Fresh Air Damper Assembly	X	X	X	X	X	X
22	131Y099	Filter Tray	X	X	X	X	X	X
23	105Y878	Left Side Support	X	X	X	X	X	X
24	147-046	Left Evaporator Support	X	X	X	X	X	X
25	135-128	Raceway	2	2	2	2	2	2
26	S111Y034	Outlet Air Frame Assembly	X	X	X	X	X	X
27	105Y877	Right Side Support	X	X	X	X	X	X
28	S143-042-* ①	Right Side Cover Plate (Outer)	X	X	X	X	X	X
28	S143-105 ②	Right Side Cover Plate (Outer)	X	X	X	X	X	X
28	S143-125 ③	Right Side Cover Plate (Outer)	X	X	X	X	X	X
29	135-129	Heat Shield	X	X	X	X	X	X
30	113-150-* ①	Top Rain Flashing	X	X	X	X	X	X
30	113-359 ②	Top Rain Flashing	X	X	X	X	X	X
31	S553-384-* ①	Filter Door Assembly	X	X	X	X	X	X
31	S552-457 ②	Filter Door Assembly	X	X	X	X	X	X
31	S553-450 ③	Filter Door Assembly	X	X	X	X	X	X
NS	S536-498	Condenser Partition Blank-Off Plate	X	X	X	X	X	X

① Exterior cabinet parts are manufactured with various paint color options. To ensure the proper paint color is received, include the complete model and serial number of the unit for which cabinet parts are being ordered.

② Exterior cabinet parts are manufactured from aluminum Code "A"

③ Exterior cabinet parts are manufactured from stainless steel Code "S"

NS = Not Shown

# FUNCTIONAL COMPONENTS - RH (shown)/LH (mirrored)

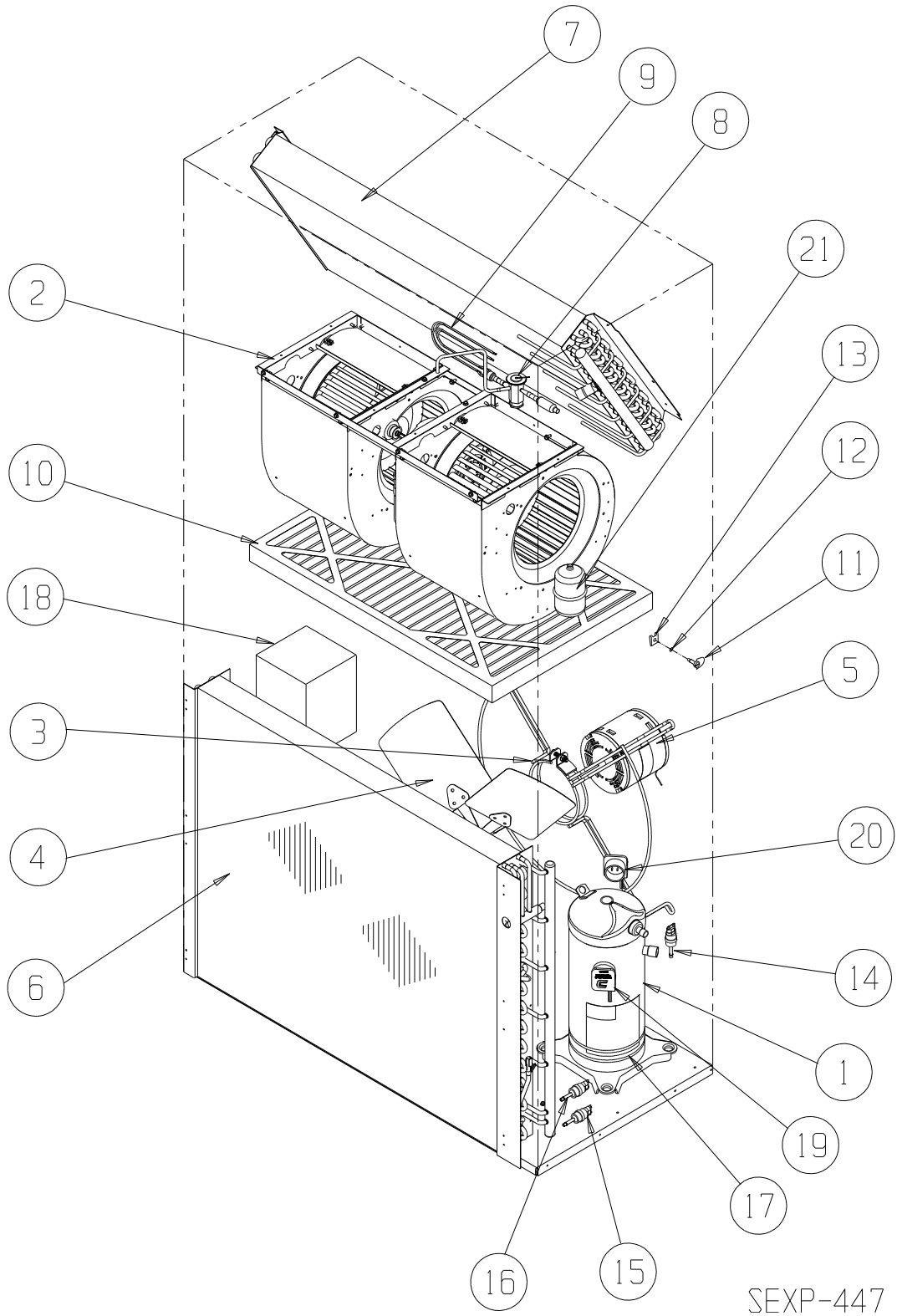

SEXP-447 A



## FUNCTIONAL COMPONENTS - RIGHT HAND

Drawing No.	Part No.	Description	WA3S3-A	WA3S3-B	WA3S3-C	WA4S3-A	WA4S3-B	WA4S3-C	WA5S3-A	WA5S3-B	WA5S3-C
1	8000-379	Compressor	X								
1	8000-380	Compressor		X							
1	8000-381	Compressor			X						
1	8000-382	Compressor				X					
1	8000-383	Compressor					X				
1	8000-384	Compressor						X			
1	8000-385	Compressor							X		
1	8000-386	Compressor								X	
1	8000-387	Compressor									X
2	S900-272-001	Blower Assembly	X	X	X						
2	S900-273-002	Blower Assembly				X	X	X			
2	S900-273-003	Blower Assembly							X	X	X
3	8200-004	Fan Motor Mount	X	X	X	X	X	X	X	X	X
4	5151-060	Fan Blade	X	X	X	X	X	X	X	X	X
5	8105-039	Condenser Motor	X	X		X	X		X	X	
5	8105-030	Condenser Motor			X			X			X
6	5051-131BX	Condenser Coil	X	X	X						
6	5051-129BX	Condenser Coil				X	X	X	X	X	X
7	5060-124BX	Evaporator	X	X	X						
7	5060-122BX	Evaporator				X	X	X	X	X	X
8	905-0634	TXV Assembly	X	X	X						
8	905-0635	TXV Assembly				X	X	X			
8	905-0636	TXV Assembly							X	X	X
9	800-0340	Cooling Distributor	X	X	X						
9	800-0342	Cooling Distributor				X	X	X	X	X	X
10	7004-016	20" x 30" x 1" Disposable	X	X	X	X	X	X	X	X	X
10	7003-030	20" x 30" x 1" Washable	X	X	X	X	X	X	X	X	X
10	7004-027	20" x 30" x 2" Pleated Filter	X	X	X	X	X	X	X	X	X
11	1171-022	1/4 Turn Fastener	X	X	X	X	X	X	X	X	X
12	1171-024	1/4 Turn Retainer	X	X	X	X	X	X	X	X	X
13	1171-023	1/4 Turn Receptacle	X	X	X	X	X	X	X	X	X
14	8406-140	Low Pressure Switch, 40 PSIG (Screw On)	X	X	X	X	X	X	X	X	X
15	8406-112	Low Ambient Control (Flare) ①	X	X	X	X	X	X	X	X	X
16	8406-142	High Pressure Switch, 650 PSIG (Screw On)	X	X	X	X	X	X	X	X	X
17	8605-017	Crankcase Heater				X	X		X	X	
17	8605-018	Crankcase Heater						X			X
17	8605-019	Crankcase Heater	X	X							
17	8605-020	Crankcase Heater			X						
18	8407-003	Step-Down Transformer 1.5 KVA			X						
18	8407-004	Step-Down Transformer 2.0 KVA						X			X
19	3000-1222	Compressor Power Lead				X			X		
19	3000-1224	Compressor Power Lead	X								
19	3000-1230	Compressor Power Lead					X	X		X	X
19	3000-1231	Compressor Power Lead		X	X						
20	3000-1223	Compressor Staging Solenoid Lead	X	X	X	X	X	X	X	X	X
21	5201-001	Liquid Line Filter Drier	X	X	X						
21	5201-002	Liquid Line Filter Drier				X	X	X	X	X	X
NS	6031-009	Coremax Valve Core	2	2	2	2	2	2	2	2	2

① = Optional

# FUNCTIONAL COMPONENTS – LEFT HAND

Drawing No.	Part No.	Description	WL3S2-A	WL3S2-B	WL3S2-C	WL4S2-A	WL4S2-B	WL4S2-C	WL5S2-A	WL5S2-B	WL5S2-C
1	8000-379	Compressor	X								
1	8000-380	Compressor		X							
1	8000-381	Compressor			X						
1	8000-382	Compressor				X					
1	8000-383	Compressor					X				
1	8000-384	Compressor						X			
1	8000-385	Compressor							X		
1	8000-386	Compressor								X	
1	8000-387	Compressor									X
2	S900-272-001	Blower Assembly	X	X	X						
2	S900-273-002	Blower Assembly				X	X	X			
2	S900-273-003	Blower Assembly							X	X	X
3	8200-004	Fan Motor Mount	X	X	X	X	X	X	X	X	X
4	5151-060	Fan Blade	X	X	X	X	X	X	X	X	X
5	8105-039	Condenser Motor	X	X		X	X		X	X	
5	8105-030	Condenser Motor			X			X			X
6	5051-165BX	Condenser Coil	X	X	X						
6	5051-166BX	Condenser Coil				X	X	X	X	X	X
7	5060-124BX	Evaporator	X	X	X						
7	5060-122BX	Evaporator				X	X	X	X	X	X
8	905-0631	TXV Assembly	X	X	X						
8	905-0632	TXV Assembly				X	X	X			
8	905-0633	TXV Assembly							X	X	X
9	800-0340	Cooling Distributor	X	X	X						
9	800-0342	Cooling Distributor				X	X	X	X	X	X
10	7004-016	20" x 30" x 1" Disposable	X	X	X	X	X	X	X	X	X
10	7003-030	20" x 30" x 1" Washable	X	X	X	X	X	X	X	X	X
10	7004-027	20" x 30" x 2" Pleated Filter	X	X	X	X	X	X	X	X	X
11	1171-022	1/4 Turn Fastener	X	X	X	X	X	X	X	X	X
12	1171-024	1/4 Turn Retainer	X	X	X	X	X	X	X	X	X
13	1171-023	1/4 Turn Receptacle	X	X	X	X	X	X	X	X	X
14	8406-140	Low Pressure Switch, 40 PSIG (Screw On)	X	X	X	X	X	X	X	X	X
15	8406-112	Low Ambient Control (Flare) ①	X	X	X	X	X	X	X	X	X
16	8406-142	High Pressure Switch, 650 PSIG (Screw On)	X	X	X	X	X	X	X	X	X
17	8605-017	Crankcase Heater				X	X		X	X	
17	8605-018	Crankcase Heater						X			X
17	8605-019	Crankcase Heater	X	X							
17	8605-020	Crankcase Heater			X						
18	8407-003	Step-Down Transformer 1.5 KVA			X						
18	8407-004	Step-Down Transformer 2.0 KVA						X			X
19	3000-1222	Compressor Power Lead	X			X			X		
19	3000-1224	Compressor Power Lead									
19	3000-1230	Compressor Power Lead					X	X		X	X
19	3000-1231	Compressor Power Lead		X	X						
20	3000-1223	Compressor Staging Solenoid Lead	X	X	X	X	X	X	X	X	X
21	5201-001	Liquid Line Filter Drier	X	X	X						
21	5201-002	Liquid Line Filter Drier				X	X	X	X	X	X
NS	6031-009	Coremax Valve Core	2	2	2	2	2	2	2	2	2

① = Optional

# CONTROL PANEL – RH (shown)/LH (mirrored)

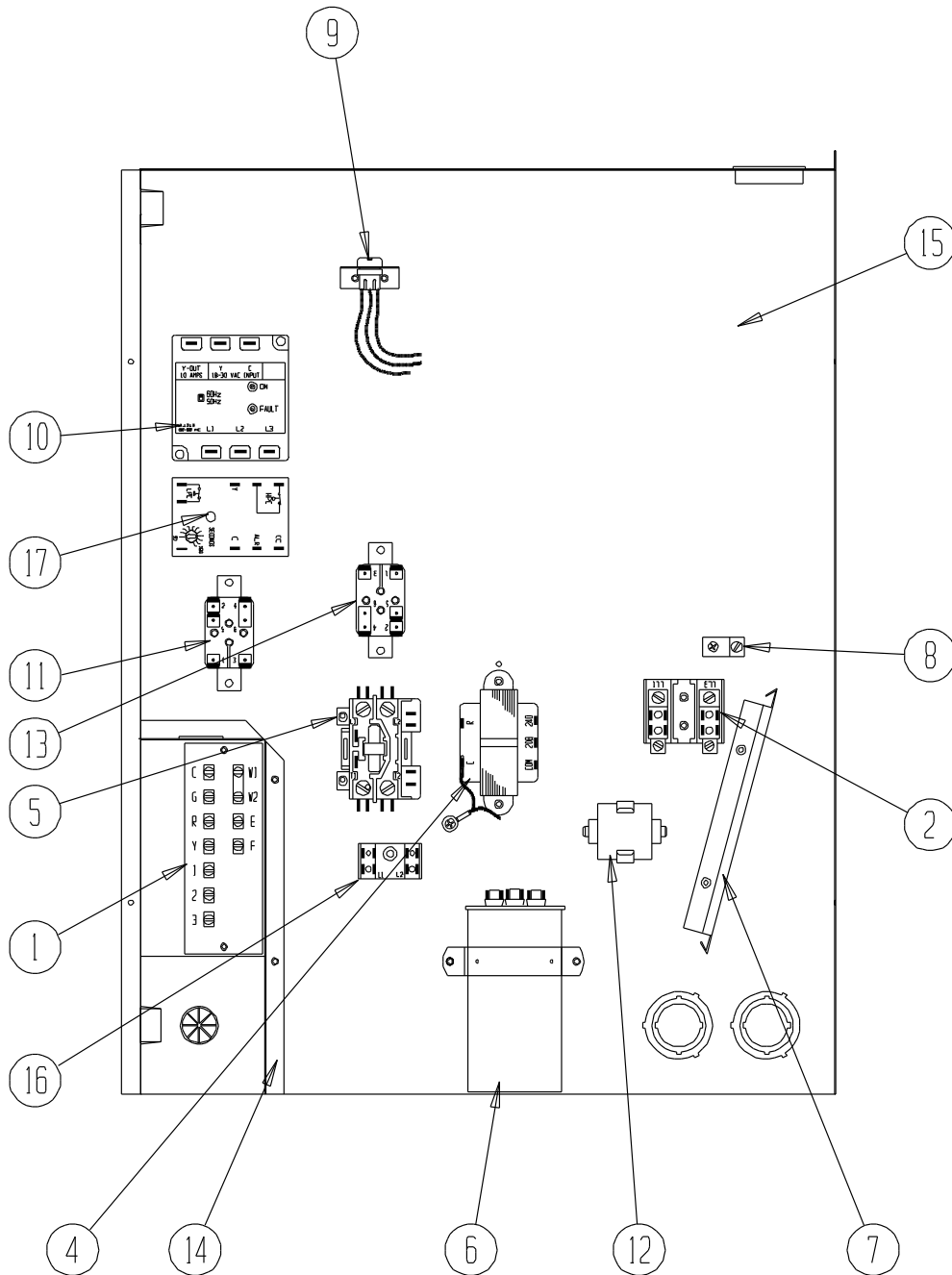

SEXP-449

# CONTROL PANEL – RIGHT HAND

Drawing No.	Part No.	Description	WA3S3-A	WA3S3-B	WA3S3-C	WA4S3-A	WA4S3-B	WA4S3-C	WA5S3-A	WA5S3-B	WA5S3-C
1	8607-024	Low Voltage Terminal Strip	X	X	X	X	X	X	X	X	X
2	8607-013	Terminal Block 2-Pole	X			X			X		
2	8607-014	Terminal Block 3-Pole		X	X		X	X		X	X
2	8607-015	Phenolic Insulator			X			X			X
4	8407-068	Transformer (50VA)	X	X		X	X		X	X	
4	8407-069	Transformer (50VA)			X			X			X
5	8401-025	Compressor Contactor	X			X			X		
5	8401-002	Compressor Contactor		X	X		X	X		X	X
6	8552-080	Compressor/Fan Capacitor	X								
6	8552-094	Compressor/Fan Capacitor				X					
6	8552-055	Compressor/Fan Capacitor							X		
6	8552-005	Outdoor Fan Capacitor		X			X			X	
6	8552-026	Outdoor Fan Capacitor			X			X			X
7	135-130	Wire Shield	X	X	X	X	X	X	X	X	X
8	8611-006	Ground Terminal	X	X	X	X	X	X	X	X	X
9	3000-1318	6-Pin Connector	X	X	X	X	X	X	X	X	X
10	8201-085	Phase Monitor (3-PH Only)		X	X		X	X		X	X
11	8201-062	Alarm Relay ①	X	X	X	X	X	X	X	X	X
12	8551-004	Motor Starting Device (1-PH Only)	X			X			X		
13	8201-009	Crankcase Heat Relay	X	X	X	X	X	X	X	X	X
14	117X139	Low Voltage Box	X	X	X	X	X	X	X	X	X
15	117X143	Control Panel	X	X	X	X	X	X	X	X	X
16	8607-017	Terminal Block ①	X	X	X	X	X	X	X	X	X
17	8201-164	Compressor Control Module	X	X	X	X	X	X	X	X	X
NS	4095-153	Wiring Diagram	X			X			X		
NS	4095-253	Wiring Diagram		X			X			X	
NS	4095-353	Wiring Diagram			X			X			X

NS = Not Shown

① = Optional

## CONTROL PANEL - LEFT HAND

Drawing No.	Part No.	Description	WL3S2-A	WL3S2-B	WL3S2-C	WL4S2-A	WL4S2-B	WL4S2-C	WL5S2-A	WL5S2-B	WL5S2-C
1	8607-024	Low Voltage Terminal Strip	X	X	X	X	X	X	X	X	X
2	8607-013	Terminal Block 2-Pole	X			X			X		
2	8607-014	Terminal Block 3-Pole		X	X		X	X		X	X
2	8607-015	Phenolic Insulator			X			X			X
4	8407-068	Transformer (50VA)	X	X		X	X		X	X	
4	8407-069	Transformer (50VA)			X			X			X
5	8401-025	Compressor Contactor	X			X			X		
5	8401-002	Compressor Contactor		X	X		X	X		X	X
6	8552-080	Compressor/Fan Capacitor	X								
6	8552-094	Compressor/Fan Capacitor				X					
6	8552-055	Compressor/Fan Capacitor							X		
6	8552-005	Outdoor Fan Capacitor		X			X			X	
6	8552-026	Outdoor Fan Capacitor			X			X			X
7	135-130	Wire Shield	X	X	X	X	X	X	X	X	X
8	8611-006	Ground Terminal	X	X	X	X	X	X	X	X	X
9	3000-1318	6-Pin Connector	X	X	X	X	X	X	X	X	X
10	8201-085	Phase Monitor (3-PH Only)		X	X		X	X		X	X
11	8201-062	Alarm Relay ①	X	X	X	X	X	X	X	X	X
12	8551-004	Motor Starting Device (1-PH Only)	X			X			X		
13	8201-009	Crankcase Heat Relay	X	X	X	X	X	X	X	X	X
14	117Y139	Low Voltage Box	X	X	X	X	X	X	X	X	X
15	117Y143	Control Panel	X	X	X	X	X	X	X	X	X
16	8607-017	Terminal Block ①	X	X	X	X	X	X	X	X	X
17	8201-148	Compressor Control Module	X	X	X	X	X	X	X	X	X
NS	4095-153	Wiring Diagram	X			X			X		
NS	4095-253	Wiring Diagram		X			X			X	
NS	4095-353	Wiring Diagram			X			X			X

NS = Not Shown

① = Optional

# BLOWER ASSEMBLY

Drawing No.	Part No.	Description	WA/L3S*-A	WA/L3S*-B	WA/L3S*-C	WA/L4S*-A	WA/L4S*-B	WA/L4S*-C	WA/L5S*-A	WA/L5S*-B	WA/L5S*-C
1	5152-011	10 Inch Wheel (CW)	X	X	X	X	X	X	X	X	X
2	5152-012	10 Inch Wheel (CCW)	X	X	X	X	X	X	X	X	X
3	S8106-052-0037A	1/2 HP ECM Motor with Programmed Control	X	X	X						
3	S8107-017-0039B	3/4 HP ECM Motor with Programmed Control				X	X	X			
3	S8107-017-0036A	3/4 HP ECM Motor with Programmed Control							X	X	X
4	C8106-052-0037A	Programmed Motor Control-Only	X	X	X						
4	C8107-017-0039B	Programmed Motor Control-Only				X	X	X			
4	C8107-017-0036A	Programmed Motor Control-Only							X	X	X
5	112-344	Blower Motor Control Bracket	X	X	X	X	X	X	X	X	X
6	8200-040	Motor Mount	X	X	X	X	X	X	X	X	X
7	5451-011	Grommets	6	6	6	6	6	6	6	6	6
8	105-881	Back Brace	X	X	X	X	X	X	X	X	X
9	105-880	Side Angle	4	4	4	4	4	4	4	4	4
10	103-389	Front Brace	X	X	X	X	X	X	X	X	X
11	151-101	Housing	2	2	2	2	2	2	2	2	2
12	144-166	Diffuser	2	2	2	2	2	2	2	2	2

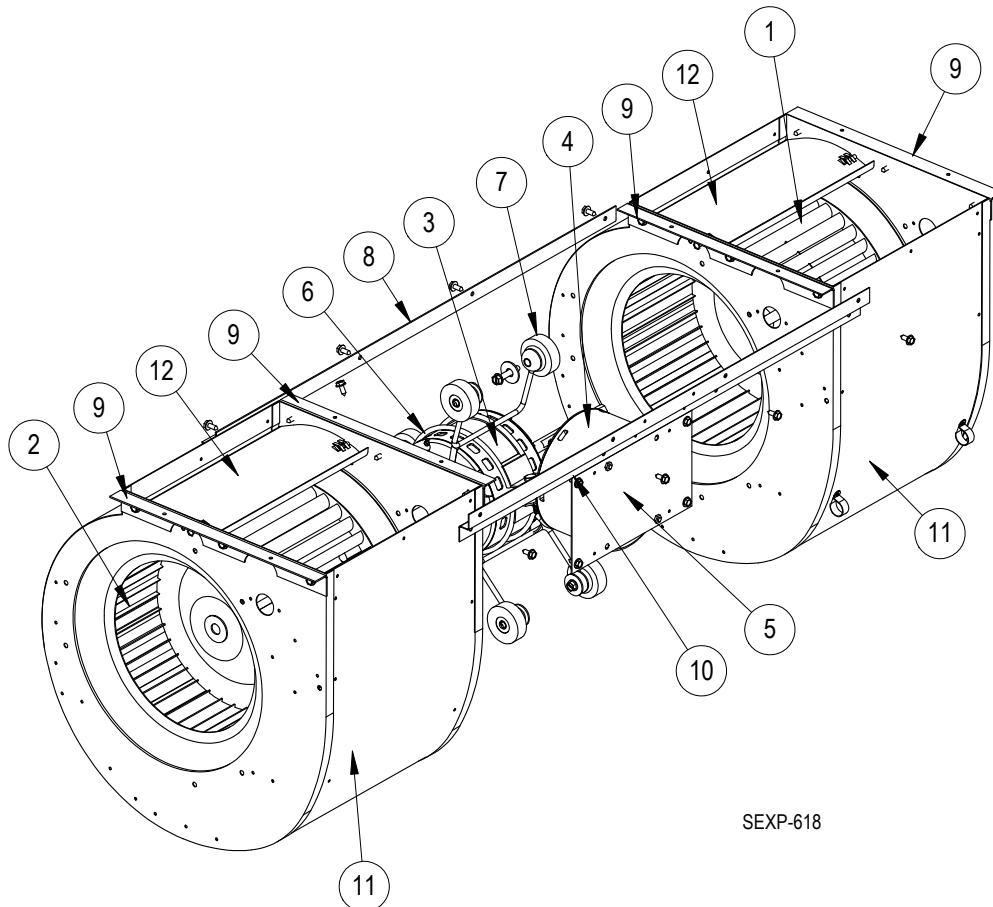

SEXP-618