REPLACEMENT PARTS MANUAL

WALL MOUNTED VARIABLE CAPACITY ENVIRONMENTAL CONTROL UNITS

Models: **W3RV1, W3LV1**

General Notes

- Revised and/or additional pages may be issued from time to time.
- A complete and current manual consists of pages shown in the following contents section.

Important

- Contact the installing and/or local Bard distributor for all parts requirements. Make sure you have the complete model and serial number available from the unit rating plates.

Contents

Description	Page
Cabinet Components	
♦ Exploded View – Right	2
♦ Usage List – Right	3
Cabinet Components	
♦ Exploded View – Left	4
♦ Usage List – Left	5
Functional Components	
♦ Exploded View – Right	6
♦ Exploded View – Left	7
♦ Usage List – Right & Left	8
Control Panel	
♦ Exploded View – Right	9
♦ Exploded View – Left	10
♦ Usage List – Right & Left	11
Blower Assembly	
♦ Exploded View	12
♦ Usage List	12



Bard Manufacturing Company, Inc.
Bryan, Ohio 43506
Since 1914...Moving ahead, just as planned.

Manual: 2110-495C
Supersedes: 2110-495B
File: Tab 16
Date: 05-02-11

CLIMATE CONTROL SOLUTIONS

CABINET COMPONENTS – RIGHT

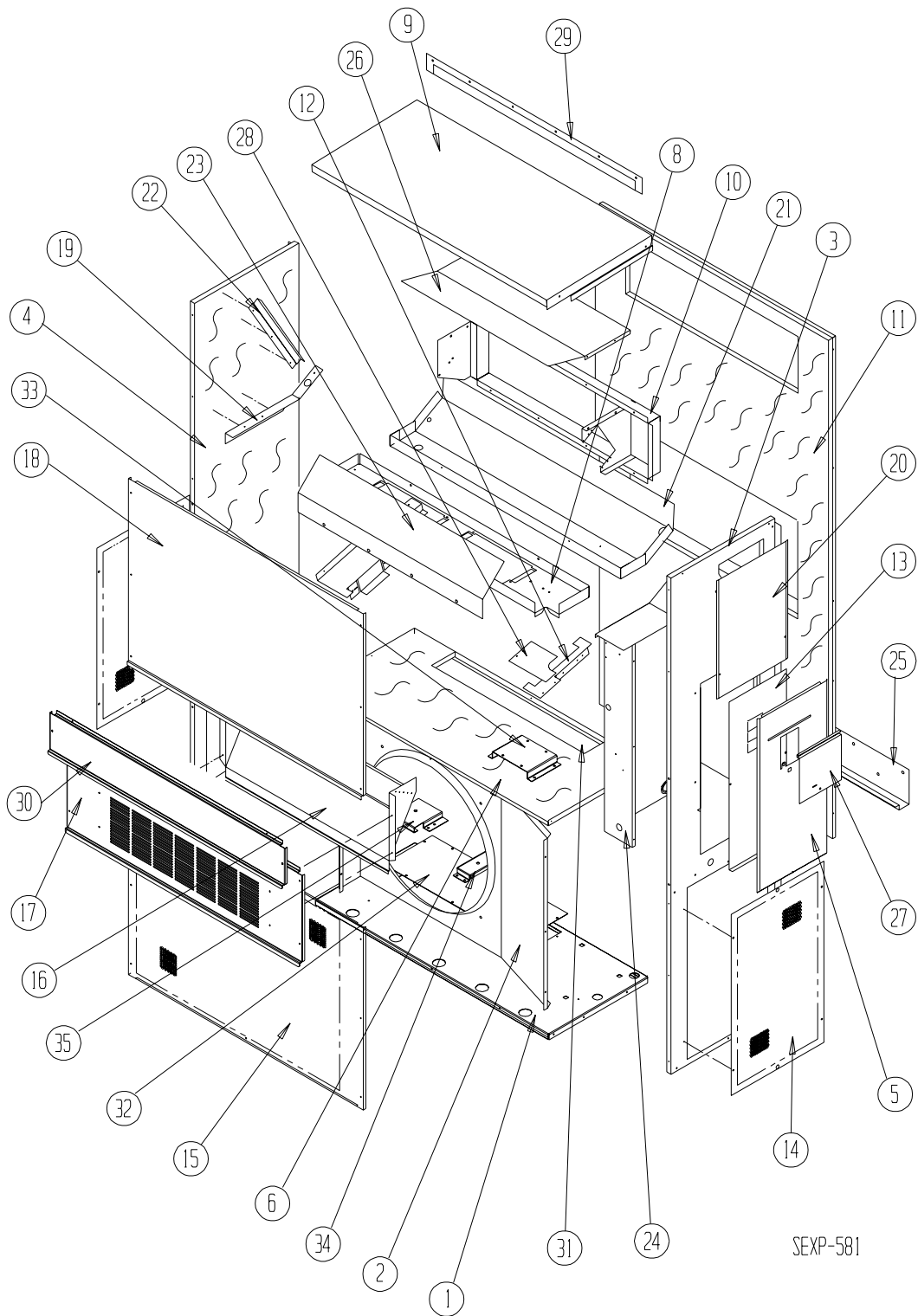

CABINET COMPONENTS – RIGHT

Drawing No.	Part No.	Description	W3RV1-R,S	W3RV1-T
1	S127X390	Lower Base	X	X
1	S127X391 ①	Lower Base	X	X
2	125-022	Fan Shroud	X	X
2	125-057 ③	Fan Shroud	X	X
3	S500-228-* ①	Right Side	X	X
3	S500-441 ②	Right Side	X	X
3	S500-527 ③	Right Side	X	X
4	S500-229-* ①	Left Side	X	X
4	S500-442 ②	Left Side	X	X
4	S500X528 ③	Left Side	X	X
5	S533-109-* ①	Control Panel Cover (Outer)	X	X
5	S533-182 ②	Control Panel Cover (Outer)	X	X
5	S533-197 ③	Control Panel Cover (Outer)	X	X
6	S521X384	Condenser Partition	X	X
8	121X182	Blower Partition	X	X
9	S506-130-* ①	Top	X	X
9	S506-245 ②	Top	X	X
9	S506-275 ③	Top	X	X
10	S111X030	Outlet Airframe Assembly	X	X
11	S508-088	Back	X	X
11	S508-185 ②	Back	X	X
11	S508-222 ③	Back	X	X
12	113X195	Filter Bracket	2	2
13	S132-104	Control Panel Cover (Inner)	X	
13	S132-208	Control Panel Cover (Inner)		X
14	118-056-* ①	Side Grille	2	2
14	118-060 ②	Side Grille	2	2
14	118-067 ③	Side Grille	2	2
15	118-059-* ①	Condenser Grille	X	X
15	118-061 ②	Condenser Grille	X	X
15	118-066 ③	Condenser Grille	X	X
16	BFAD-3	Fresh Air Damper Assembly	X	X
17	S552-443-* ①	Vent Option Door	X	X
17	S552-446 ②	Vent Option Door	X	X
17	S552-458 ③	Vent Option Door	X	X
18	S514-160-* ①	Upper Front	X	X
18	S514-161 ②	Upper Front	X	X
18	S514-166 ③	Upper Front	X	X
19	105X850	Left Side Support	X	X
20	S143-034-* ①	Right Side Cover Plate (Outer)	X	X
20	S143-103 ②	Right Side Cover Plate (Outer)	X	X
20	S143-127 ③	Right Side Cover Plate (Outer)	X	X
21	S123-127	Drain Pan	X	X
22	147-044	Evaporator Support	X	X
23	135-124	Air Baffle	X	X
24	Control Panel Assembly	See Control Panel Assembly Drawing and Parts List	X	X
25	113-140	Bottom Mounting Bracket	1	1
26	135X123	Heat Shield	X	X
27	S153-218-* ①	Disconnect Access Door	X	X
27	S153-387 ②	Disconnect Access Door	X	X
27	S153-405 ③	Disconnect Access Door	X	X
28	137-259	Fill Plate	X	X
29	113-149-* ①	Top Rain Flashing	X	X
29	113-360 ③	Top Rain Flashing	X	X
30	S552-444-* ①	Filter Door	X	X
30	S552-447 ②	Filter Door	X	X
30	S552-459 ③	Filter Door	X	X
31	S536X609	Condenser Partition Block-Off Plate	X	X
32	136-607	Base Grille Plate	X	X
32	136-608 ①	Base Grille Plate	X	X
33	113-412	Fan Motor Control Mount	X	X
34	113-406	Accumulator Bracket	X	X
35	113-407	Receiver Bracket	X	X

① Exterior cabinet parts are manufactured with various paint color options. To insure that you receive the proper paint color, you must include the complete model and serial number of the unit for which cabinet parts are being ordered.

② Note: Exterior cabinet parts are manufactured from aluminum Code "A"

③ Note: Exterior cabinet parts are manufactured from stainless steel Code "S"

CABINET COMPONENTS – LEFT

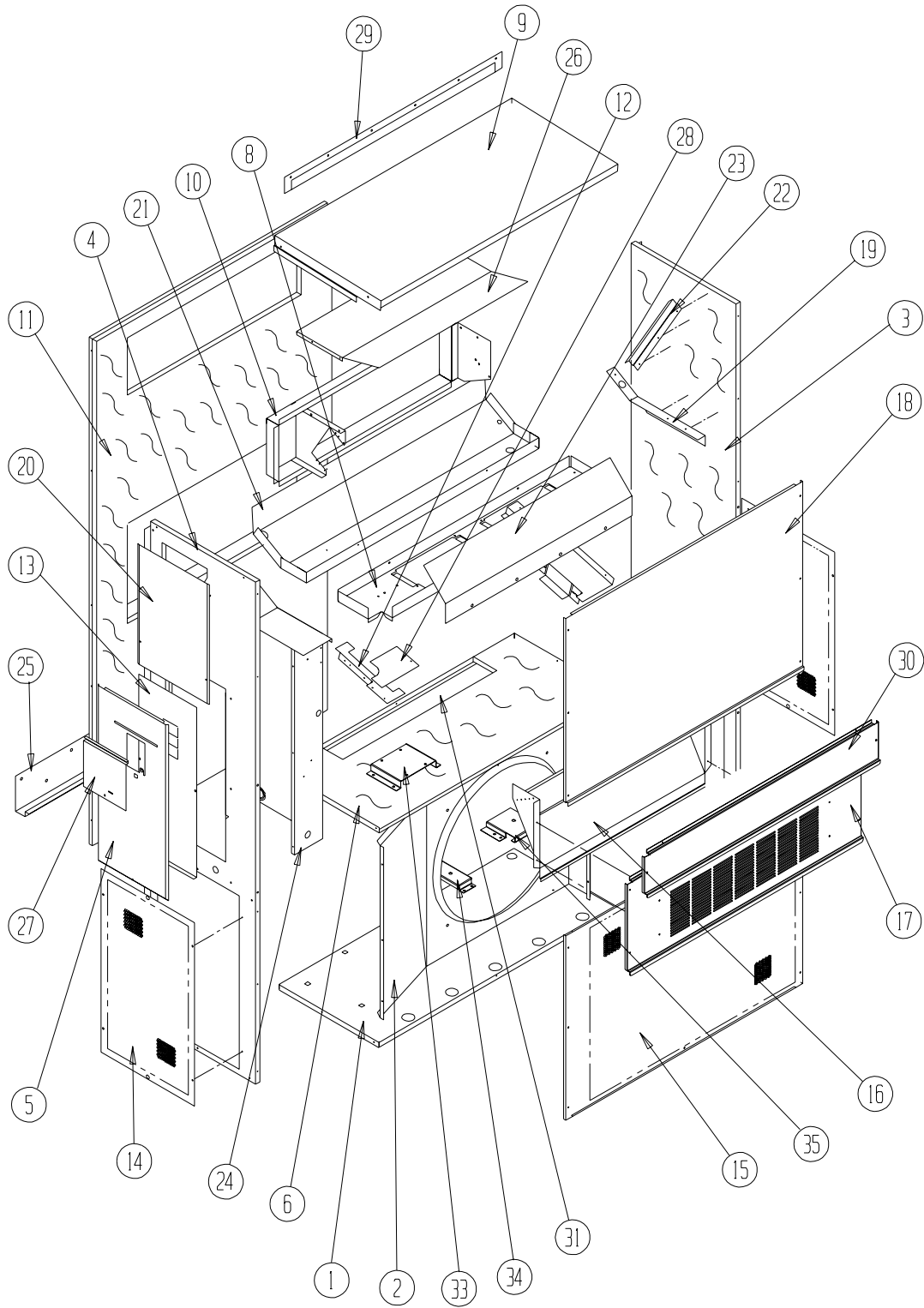

SEXP-584

CABINET COMPONENTS – LEFT

Drawing No.	Part No.	Description	W3LV1-R,S	W3LV1-T
1	S127Y199	Lower Base	X	X
1	S127Y368 ③	Lower Base	X	X
2	125-022	Fan Shroud	X	X
2	125-057 ③	Fan Shroud	X	X
3	S500-318-* ①	Right Side	X	X
3	S500-458 ②	Right Side	X	X
3	S500Y528 ③	Right Side	X	X
4	S500-317-* ①	Left Side	X	X
4	S500-459 ②	Left Side	X	X
4	S500-529 ③	Left Side	X	X
5	S533-136-* ①	Control Panel Cover (Outer)	X	X
5	S533-184 ②	Control Panel Cover (Outer)	X	X
5	S533-204 ③	Control Panel Cover (Outer)	X	X
6	S521Y384	Condenser Partition	X	X
8	121Y182	Blower Partition	X	X
9	S506-130-* ①	Top	X	X
9	S506-245 ②	Top	X	X
9	S506-275 ③	Top	X	X
10	S111Y030	Outlet Airframe Assembly	X	X
11	S508-088	Back	X	X
11	S508-185 ②	Back	X	X
11	S508-222 ③	Back	X	X
12	113Y195	Filter Bracket	2	2
13	S132-104	Control Panel Cover (Inner)	X	
13	S132-208	Control Panel Cover (Inner)		X
14	118-056-* ①	Side Grille	2	2
14	118-060 ②	Side Grille	2	2
14	118-067 ③	Side Grille	2	2
15	118-047-* ①	Condenser Grille	X	X
15	118-062 ②	Condenser Grille	X	X
15	118-075 ③	Condenser Grille	X	X
16	BFAD-3	Fresh Air Damper Assembly	X	X
17	S552-443-* ①	Vent Option Door	X	X
17	S552-446 ②	Vent Option Door	X	X
17	S552-458 ③	Vent Option Door	X	X
18	S514-160-* ①	Upper Front	X	X
18	S514-161 ②	Upper Front	X	X
18	S514-166 ③	Upper Front	X	X
19	105Y850	Left Side Support	X	X
20	S143-034-* ①	Side Cover Plate (Outer)	X	X
20	S143-103 ②	Side Cover Plate (Outer)	X	X
20	S143-127 ③	Side Cover Plate (Outer)	X	X
21	S123-130	Drain Pan	X	X
22	147-044	Right Evaporator Support	X	X
23	135-124	Air Baffle	X	X
24	Control Panel Assembly	See Control Panel Assembly Drawing and Parts List	X	X
25	113-140	Bottom Mounting Bracket	1	1
26	135Y123	Heat Shield	X	X
27	S153-218-* ①	Disconnect Access Door	X	X
27	S153-387 ②	Disconnect Access Door	X	X
27	S153-405 ③	Disconnect Access Door	X	X
28	137-259	Fill Plate	X	X
29	113-149-* ①	Top Rain Flashing	X	X
29	113-360 ③	Top Rain Flashing	X	X
30	S552-444-* ①	Filter Door	X	X
30	S552-447 ②	Filter Door	X	X
30	S552-459 ③	Filter Door	X	X
31	S536Y609	Condenser Partition Block-Off Plate	X	X
33	113-412	Fan Motor Control Mount	X	X
34	113-406	Accumulator Bracket	X	X
35	113-407	Receiver Bracket	X	X

① Exterior cabinet parts are manufactured with various paint color options. To insure that you receive the proper paint color, you must include the complete model and serial number of the unit for which cabinet parts are being ordered.

② Note: Exterior cabinet parts are manufactured from aluminum Code "A"

③ Note: Exterior cabinet parts are manufactured from stainless steel Code "S"

FUNCTIONAL COMPONENTS – RIGHT HAND

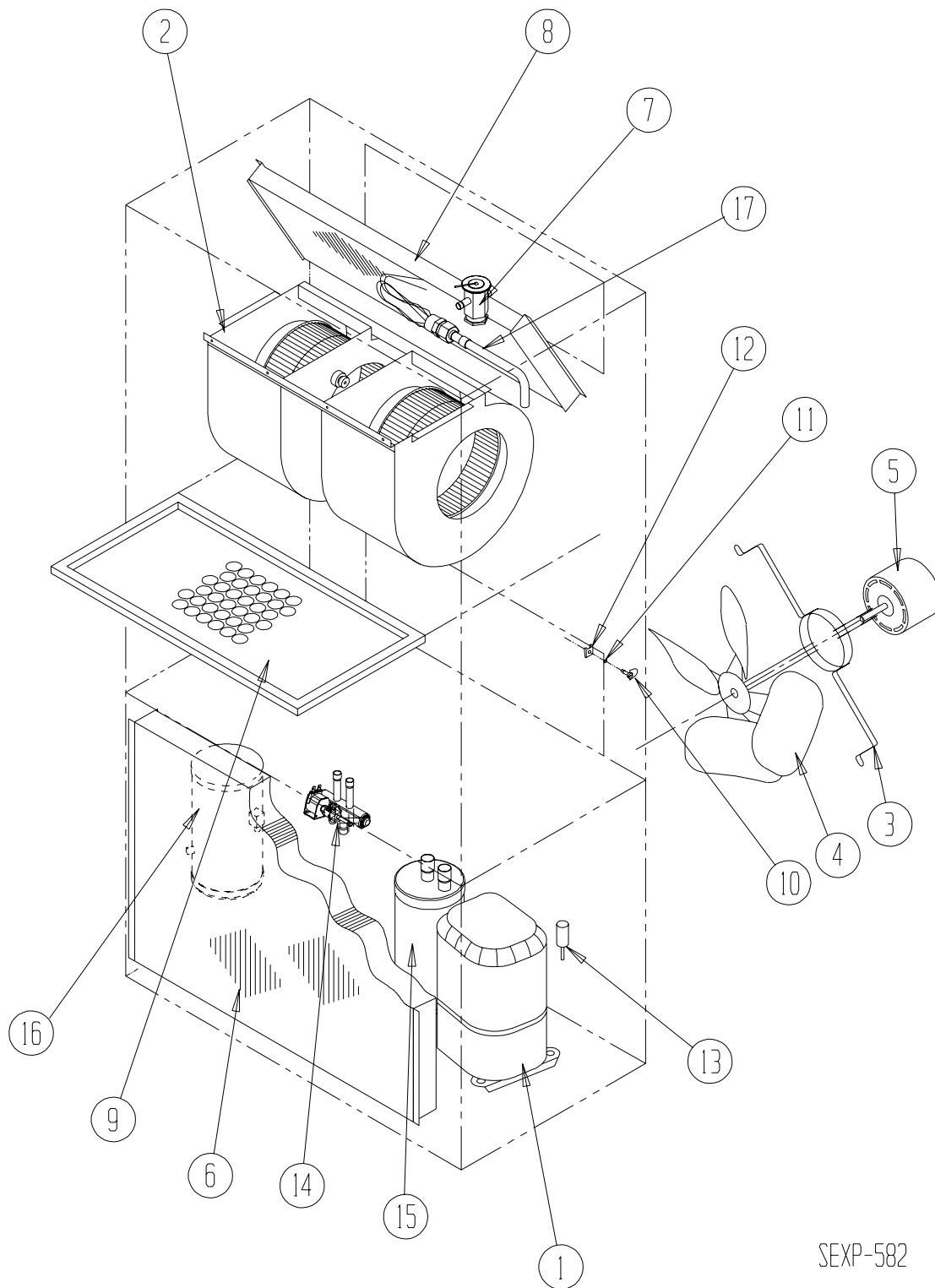

SEXP-582

FUNCTIONAL COMPONENTS – LEFT HAND

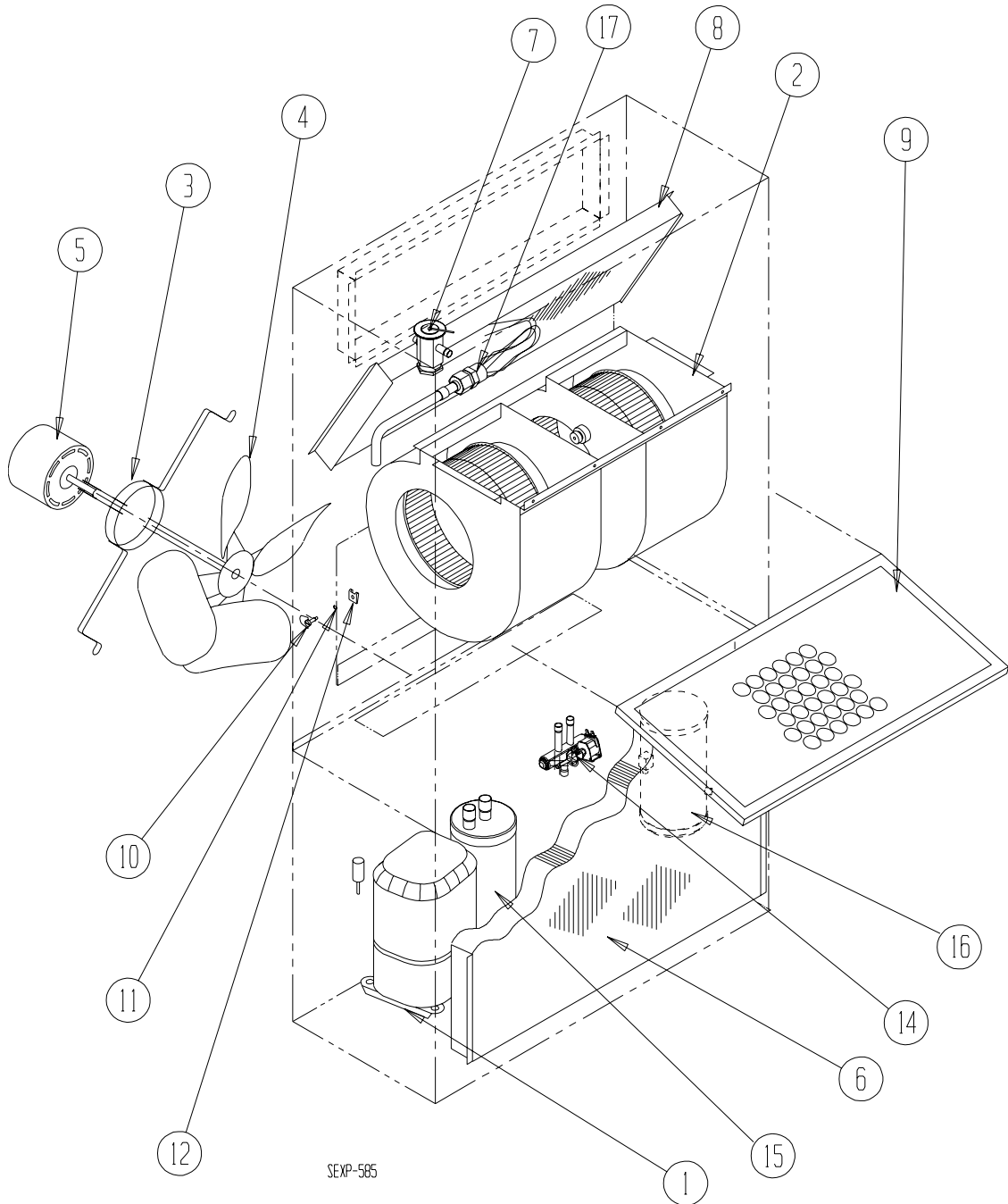

FUNCTIONAL COMPONENTS – RIGHT & LEFT HAND

Drawing No.	Part No.	Description	W3RV1-R	W3RV1-S	W3RV1-T	W3LV1-R	W3LV1-S	W3LV1-T
1	8000-355	Compressor	X			X		
1	8000-356	Compressor		X			X	
1	8000-357	Compressor			X			X
2	S900-307-001	Blower Assembly	X	X	X	X	X	X
3	8200-001	Fan Motor Mount	X	X	X	X	X	X
4	5151-045	Fan Blade	X	X	X	X	X	X
5	S8106-047-0076	1/2 HP ECM Motor with Programmed Control	X	X	X	X	X	X
5	C8106-047-0076	Programmed Motor Control - Only	X	X	X	X	X	X
6	5051-066BX	Condenser Coil	X	X	X			
6	5051-089BX	Condenser Coil				X	X	X
7	5651-214	Cooling TXV	X	X	X	X	X	X
8	5060-064BX	Evaporator Coil	X	X	X	X	X	X
9	7004-019	Air Filter 1" Throw-Away	X	X	X	X	X	X
9	7003-031	Air Filter 1" Washable ①	X	X	X	X	X	X
9	7004-026	Air Filter 2" Pleated ①	X	X	X	X	X	X
10	1171-022	1/4 Turn Fastener	X	X	X	X	X	X
11	1171-024	1/4 Turn Retainer	X	X	X	X	X	X
12	1171-023	1/4 Turn Receptacle	X	X	X	X	X	X
13	1804-0385	High Pressure Switch (Flare)	X	X	X	X	X	X
13	1804-0107	Low Pressure Switch (Flare)	X	X	X	X	X	X
14	5650-049	Solenoid Valve	X	X	X	X	X	X
15	5202-022	Accumulator	X	X	X	X	X	X
16	5203-004	Receiver	X	X	X	X	X	X
17	800-0392	Cooling Distributor Assembly	X	X	X	X	X	X
NS	5201-001	Filter Drier	X	X	X	X	X	X
NS	8605-017	Crankcase Heater	X	X		X	X	
NS	8605-018	Crankcase Heater			X			X
NS	8408-039	Discharge Line Thermostat	X	X	X	X	X	X
NS	8406-128	Pressure Transducer	X	X	X	X	X	X

NS – Not Shown

① – Optional

CONTROL PANEL – RIGHT HAND

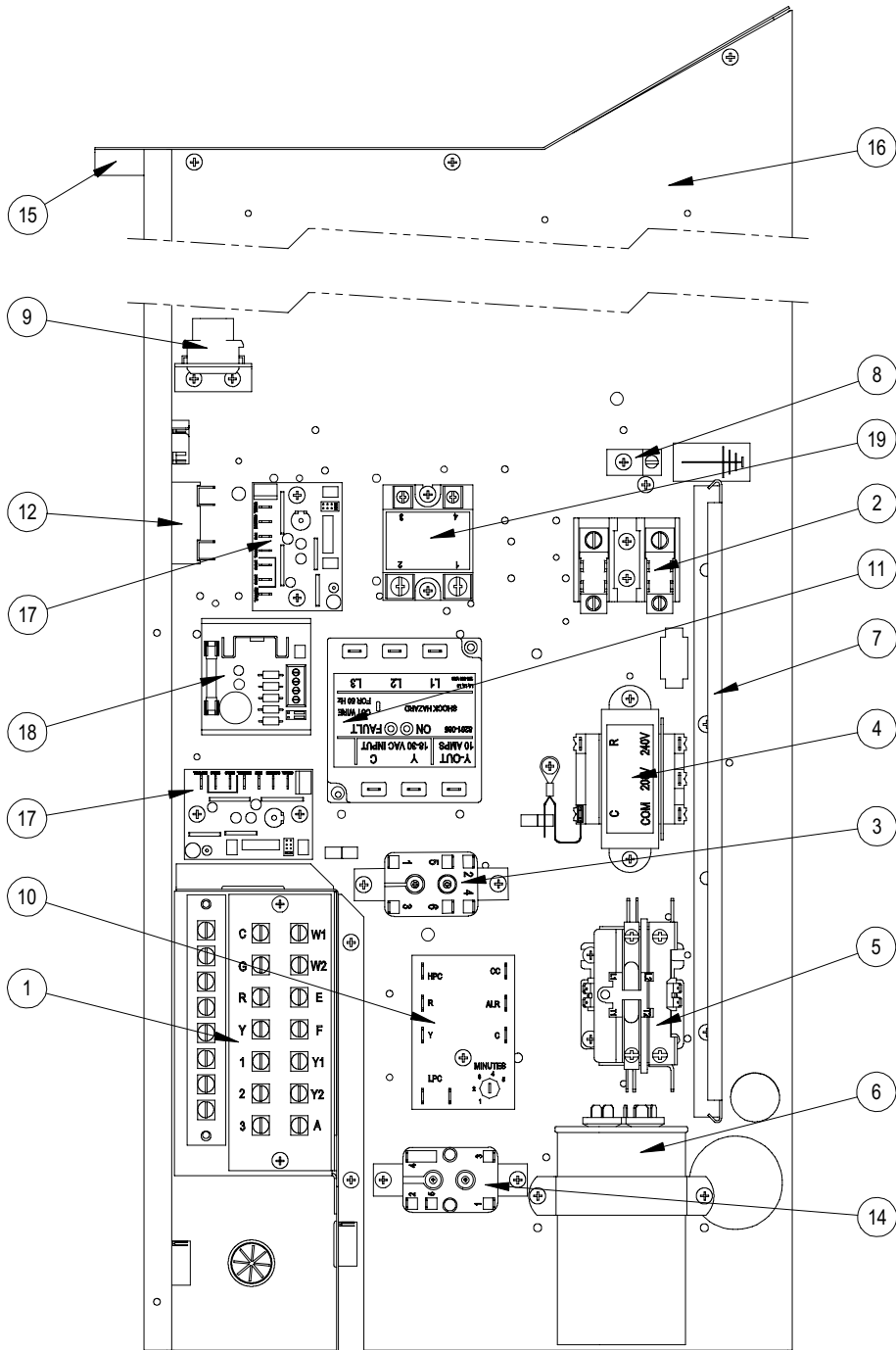

SXP-580

CONTROL PANEL – LEFT HAND

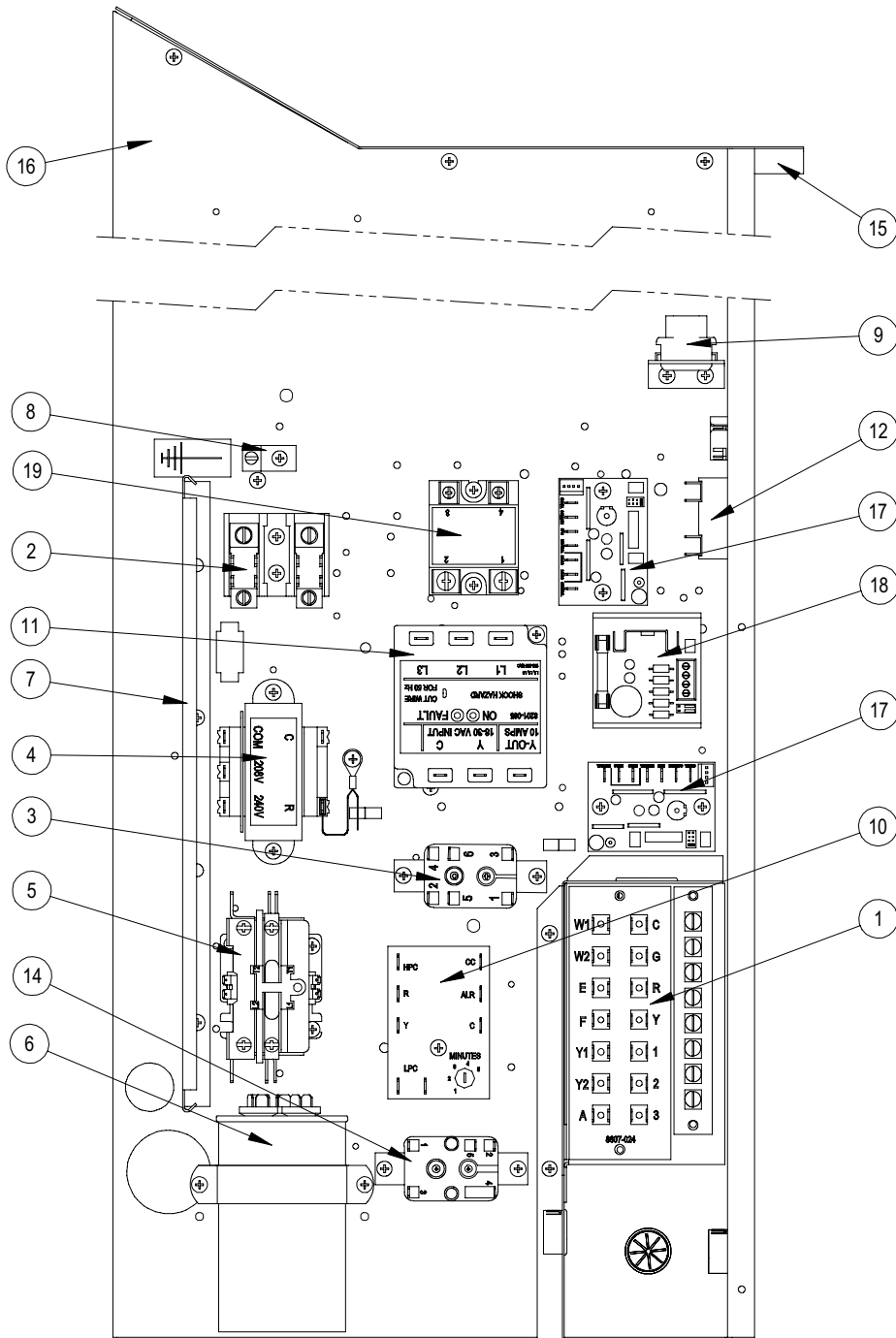

SEXP-586

CONTROL PANEL – RIGHT & LEFT HAND

Drawing No.	Part No.	Description	W3RV1-R	W3RV1-S	W3RV1-T	W3LV1-R	W3LV1-S	W3LV1-T
1	8607-024	Low Voltage Terminal Strip	X	X	X	X	X	X
2	8607-013	Terminal Block 2 Pole	X			X		
2	8607-014	Terminal Block 3 Pole		X	X		X	X
2	8607-015	Phenolic Insulator			X			X
3	8201-009	Crankcase Heat Relay	X			X		
4	8407-048	Transformer	X	X		X	X	
4	8407-050	Transformer			X			X
5	8401-007	Compressor Contactor	X			X		
5	8401-027	Compressor Contactor		X	X		X	X
6	8552-01	Compressor Capacitor	X			X		
7	135-122	Wire Shield	X	X	X	X	X	X
8	8611-006	Ground Terminal	X	X	X	X	X	X
9	3000-1357	6 Pin Connector	X	X	X	X	X	X
10	8201-088	Compressor Control Module (Optional)	X	X	X	X	X	X
11	8201-126	Phase Monitor		X	X		X	X
12	8607-017	Terminal Block			X			X
14	8201-062	Alarm Relay	X	X	X	X	X	X
15	117X137	Control Panel Top	X	X	X			
15	117Y137	Control Panel Top				X	X	X
16	117X123	Control Panel	X	X	X			
16	117Y123	Control Panel				X	X	X
17	8201-124	Blower Control Board	2	2	2	2	2	2
18	8301-033	5VDC Supply	X	X	X	X	X	X
19	8201-123	Solid State Relay	X	X	X	X	X	X
NS	8301-014	Outdoor Air Sensor	X	X	X	X	X	X
NS	8403-066	Thermostat Controller	X	X	X	X	X	X
NS	8614-041	Fuse Block			X			X
NS	8614-042	Fuses			X			X
NS	8615-038	Circuit Breaker 35A 2 Pole (Opt) ①	X			X		
NS	8615-052	Circuit Breaker 30A 3 Pole (Opt) ①		X			X	
NS	8615-068	Toggle Disconnect (Optional)			X			X
NS	3000-1356	Indoor Blower Power Harness	X	X	X	X	X	X
NS	3000-1358	Indoor Blower Low Voltage	X	X	X	X	X	X
NS	3000-1359	Outdoor Blower Low Voltage	X	X	X	X	X	X
NS	3000-1360	Pressure Transducer Harness	X	X	X	X	X	X
NS	3000-1276	Compressor Harness	X			X		
NS	3000-1244	Compressor Harness		X	X		X	X
NS	4095-157	Wiring Diagram	X			X		
NS	4095-254	Wiring Diagram		X			X	
NS	4095-354	Wiring Diagram			X			X

NS – Not Shown

① Circuit breakers listed are for units without electric heat "0Z" models.
See Heater Replacement Parts Manual for units with electric heat.

BLOWER ASSEMBLY

900-307-001

Drawing No.	Part No.	Description	
1	151-111	Blower Housing	2
2	144-174	Diffuser	2
3	S8106-041-0075	Programmed Motor w/Control	X
4	C8106-041-0075	Programmed Motor Control-Only	X
5	8200-031	Motor Mount	X
6	5451-011	Grommets	6
7	105-870	Back Brace </td <td>X</td>	X
8	103-401	Front Brace	X
9	5152-090	Wheel (CW)	X
10	5152-091	Wheel (CCW)	X
11	113-314	Blower Motor Control Mount	X

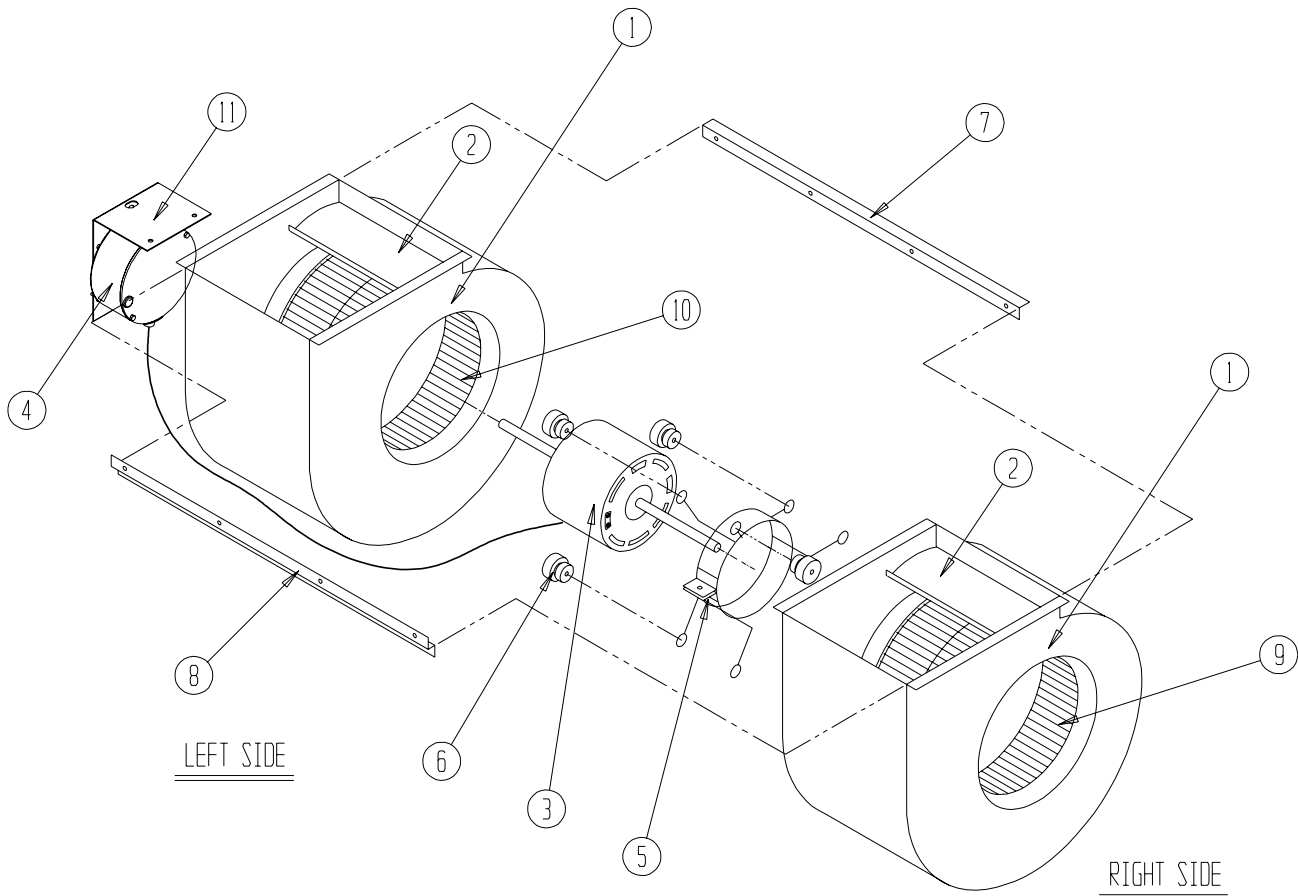

SEXP-583