REPLACEMENT PARTS MANUAL

WALL MOUNTED VARIABLE CAPACITY ENVIRONMENTAL CONTROL UNITS

Models: **W5RV1 W5LV1**

General Notes

- Revised and/or additional pages may be issued from time to time.
- A complete and current manual consists of pages shown in the following contents section.

Important

- Contact the installing and/or local Bard distributor for all parts requirements. Make sure you have the complete model and serial number available from the unit rating plates.

Contents

Description	Page
Cabinet Components — Right & Left	
♦ Exploded View (Right)	2
♦ Usage List	3
♦ Exploded View (Left)	4
♦ Usage List	5
Functional Components — Right & Left	
♦ Exploded View (Right)	6
♦ Exploded View (Left)	7
♦ Usage List	8
Control Panel — Right & Left	
♦ Exploded View (Right)	10
♦ Exploded View (Left)	11
♦ Usage List	12
Blower Assembly	
♦ Exploded View	13
♦ Usage List	13



Bard Manufacturing Company, Inc.
Bryan, Ohio 43506
Since 1914...Moving ahead, just as planned.

Manual: 2110-496B
Supersedes: 2110-496A
File: Tab 16
Date: 05-02-11

CABINET COMPONENTS — RIGHT

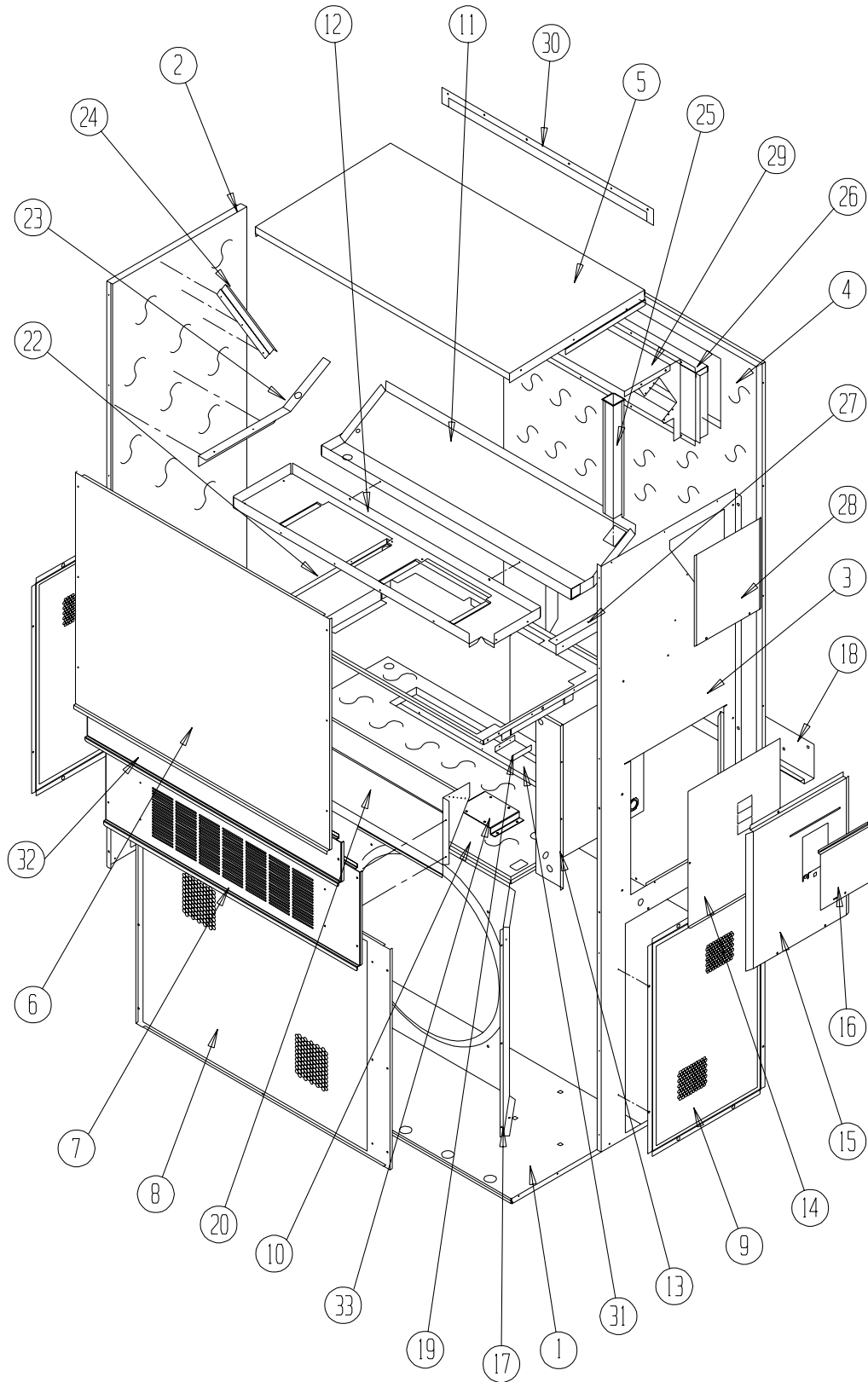

SEXP-587

This Exploded View references Table on Page 3

CABINET COMPONENTS — RIGHT

Dwg. No.	Part Number	Description	W5RV1-R, S	
			W5RV1-R	W5RV1-T
1	S127X214	Lower Base	X	X
1	S127X369 ③	Lower Base	X	X
2	S500-262-* ①	Left Side	X	X
2	S500-464 ②	Left Side	X	X
2	S500X516 ③	Left Side	X	X
3	S500-261-* ①	Right Side	X	X
3	S500-463 ②	Right Side	X	X
3	S500-517 ③	Right Side	X	X
4	S508-098	Back	X	X
4	S508-191 ②	Back	X	X
4	S508-221 ③	Back	X	X
5	S506-142-* ①	Top	X	X
5	S506-251 ②	Top	X	X
5	S506-274 ③	Top	X	X
6	S515-144-* ①	Upper Front	X	X
6	S514-142 ②	Upper Front	X	X
6	S514-162 ③	Upper Front	X	X
7	S552-383-* ①	Vent Option Door	X	X
7	S553-408-* ①	Vent Option Door with ERV	X	X
7	S552-456 ②	Vent Option Door	X	X
7	S553-449 ③	Vent Option Door	X	X
8	118-048-* ①	Condenser Grille	X	X
8	118-064 ②	Condenser Grille	X	X
8	118-072 ③	Condenser Grille	X	X
9	118-057-* ①	Side Grille	2	2
9	118-063 ②	Side Grille	2	2
9	118-073 ③	Side Grille	2	2
10	S521X258	Condenser Partition	X	X
11	S123-102	Drain Pan	X	X
12	121X216	Blower Partition	X	X
13	Control Panel Assy.	See Control Panel Assy. Dwg. & Parts List	X	X
14	S132-114	Control Panel Cover (Inner)	X	
14	S132-171	Control Panel Cover (Inner)		X
15	S533-113-* ①	Control Panel Cover (Outer)	X	X
15	S533-185 ②	Control Panel Cover (Outer)	X	X
15	S533-195 ③	Control Panel Cover (Outer)	X	X
16	S153-218-* ①	Disconnect Access Door	X	X
16	S153-387 ②	Disconnect Access Door	X	X
16	S153-405 ③	Disconnect Access Door	X	X
17	125-024	Fan Shroud	X	X
17	125-058 ③	Fan Shroud	X	X
18	113-140	Bottom Mounting Bracket	X	X
19	137-209	Fill	X	X
20	BFAD-5	Fresh Air Damper Assembly	X	X
22	131X099	Filter Tray	X	X
23	105X877	Left Side Support	X	X
24	147-046	Left Evaporator Support	X	X
25	135-128	Raceway	X	X
26	S111X034	Outlet Air Frame Assembly	X	X
27	105X878	Right Side Support	X	X
28	S143-042-* ①	Right Side Cover Plate (Outer)	X	X
28	S143-105 ②	Right Side Cover Plate (Outer)	X	X
28	S143-125 ③	Right Side Cover Plate (Outer)	X	X
29	135-129	Heat Shield	X	X
30	113-150-* ①	Top Rain Flashing	X	X
30	113-359 ③	Top Rain Flashing	X	X
31	S536X610	Cond. Partition Block Off Plate	X	X
32	S553-384-* ①	Filter Door Assembly	X	X
32	S552-457 ②	Filter Door Assembly	X	X
32	S553-450 ③	Filter Door Assembly	X	X
33	113-412	Fan Motor Control Mount	X	X

① Exterior cabinet parts are manufactured with various paint color options. To insure that you receive the proper paint color, you must include the complete model and serial number of the unit for which cabinet parts are being ordered.

② Note: Exterior cabinet parts are manufactured from aluminum Code "A"

③ Note: Exterior cabinet parts are manufactured from stainless steel Code "S"

CABINET COMPONENTS — LEFT

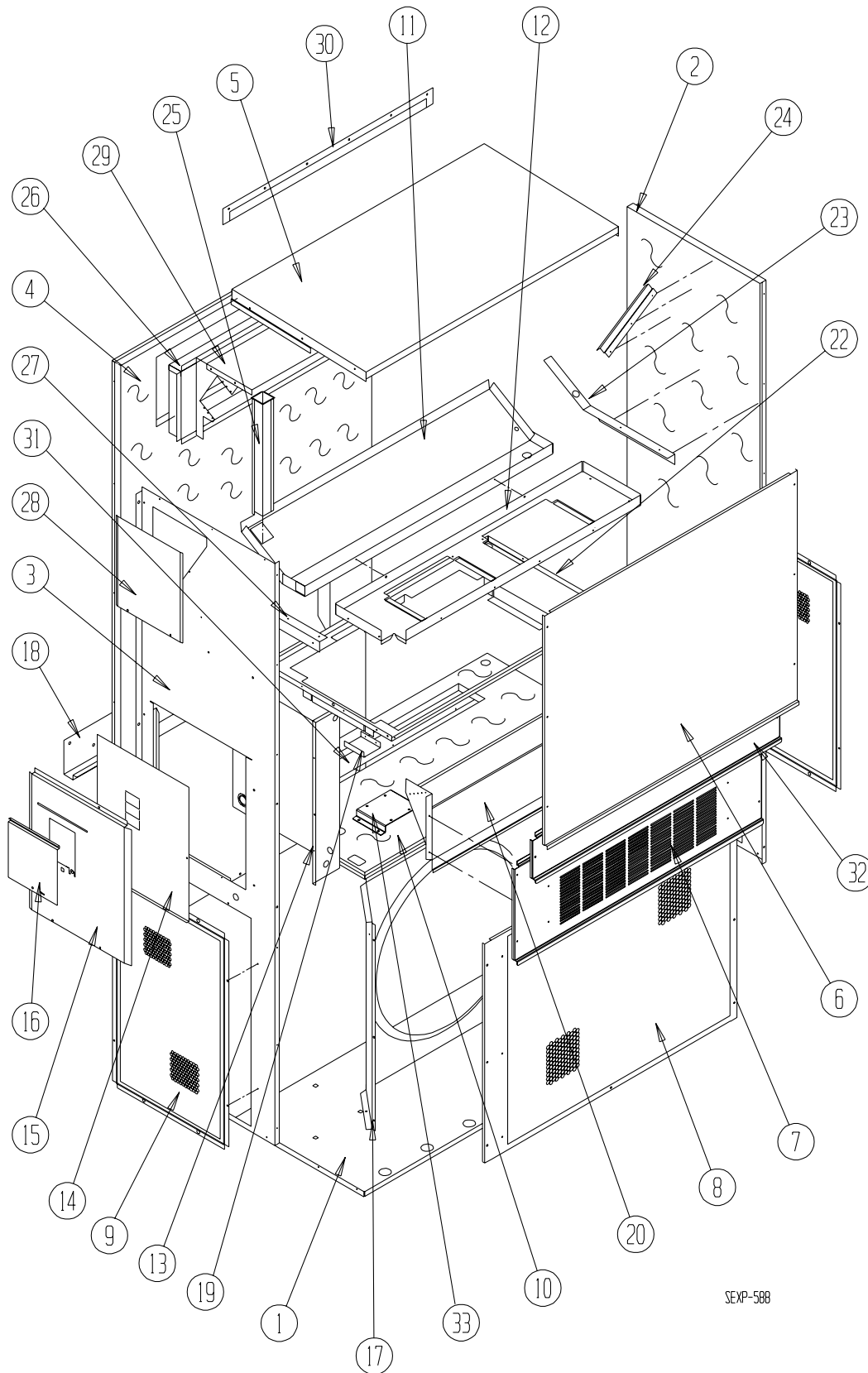

SEXP-588

This Exploded View references Table on Page 5

CABINET COMPONENTS — LEFT

Drawing No.	Part No.	Description	W5LV1-R, S	
			W5LV1-T	
1	S127Y214	Lower Base	X	X
1	S127Y369 ③	Lower Base	X	X
2	S500-319-* ①	Right Side	X	X
2	S500-465 ②	Right Side	X	X
2	S500Y516 ③	Right Side	X	X
3	S500-320-* ①	Left Side	X	X
3	S500-466 ②	Left Side	X	X
3	S500-519 ③	Left Side	X	X
4	S508-098	Back	X	X
4	S508-191 ②	Back	X	X
4	S508-221 ③	Back	X	X
5	S506-142-* ①	Top	X	X
5	S506-251 ②	Top	X	X
5	S506-274 ③	Top	X	X
6	S515-144-* ①	Upper Front	X	X
6	S514-142 ②	Upper Front	X	X
6	S514-162 ③	Upper Front	X	X
7	S552-383-* ①	Vent Option Door	X	X
7	S552-456 ②	Vent Option Door	X	X
7	S553-449 ③	Vent Option Door	X	X
8	118-049-* ①	Condenser Grille	X	X
8	118-065 ②	Condenser Grille	X	X
8	118-074 ③	Condenser Grille	X	X
9	118-057-* ①	Side Grille	2	2
9	118-063 ②	Side Grille	2	2
9	118-073 ③	Side Grille	2	2
10	S521Y258	Condenser Partition	X	X
11	123-091	Drain Pan	X	X
12	121Y216	Blower Partition	X	X
13	Control Panel Assembly	See Control Panel Assembly Drawing & Parts List	X	X
14	S133-114	Control Panel Cover (Inner)	X	
14	S133-171	Control Panel Cover (Inner)		X
15	S533-140-* ①	Control Panel Cover (Outer)	X	X
15	S533-186 ②	Control Panel Cover (Outer)	X	X
15	S533-203 ③	Control Panel Cover (Outer)	X	X
16	S153-218-* ①	Disconnect Access Door	X	X
16	S153-387 ②	Disconnect Access Door	X	X
16	S153-405 ③	Disconnect Access Door	X	X
17	125-024	Fan Shroud	X	X
17	125-058 ③	Fan Shroud	X	X
18	113-140	Bottom Mounting Bracket	X	X
19	137-209	Fill	X	X
20	BFAD-5	Fresh Air Damper Assembly	X	X
22	131Y099	Filter Tray	X	X
23	105Y878	Left Side Support	X	X
24	147-046	Left Evaporator Support	X	X
25	135-128	Raceway	2	2
26	S111Y034	Outlet Air Frame Assembly	X	X
27	105Y877	Right Side Support	X	X
28	S143-042-* ①	Right Side Cover Plate (Outer)	X	X
28	S143-105 ②	Right Side Cover Plate (Outer)	X	X
28	S143-125 ③	Right Side Cover Plate (Outer)	X	X
29	135-129	Heat Shield	X	X
30	113-150-* ①	Top Rain Flashing	X	X
30	113-359 ③	Top Rain Flashing	X	X
31	S536Y610	Condenser Partition Block Off Plate	X	X
32	S553-384-* ①	Filter Door Assembly	X	X
32	S552-457 ②	Filter Door Assembly	X	X
32	S553-450 ③	Filter Door Assembly	X	X
33	113-412	Fan Motor Control Board	X	X

① Exterior cabinet parts are manufactured with various paint color options. To insure that you receive the proper paint color, you must include the complete model and serial number of the unit for which cabinet parts are being ordered.

② Note: Exterior cabinet parts are manufactured from aluminum Code "A"

③ Note: Exterior cabinet parts are manufactured from stainless steel Code "S"

FUNCTIONAL COMPONENTS — RIGHT HAND

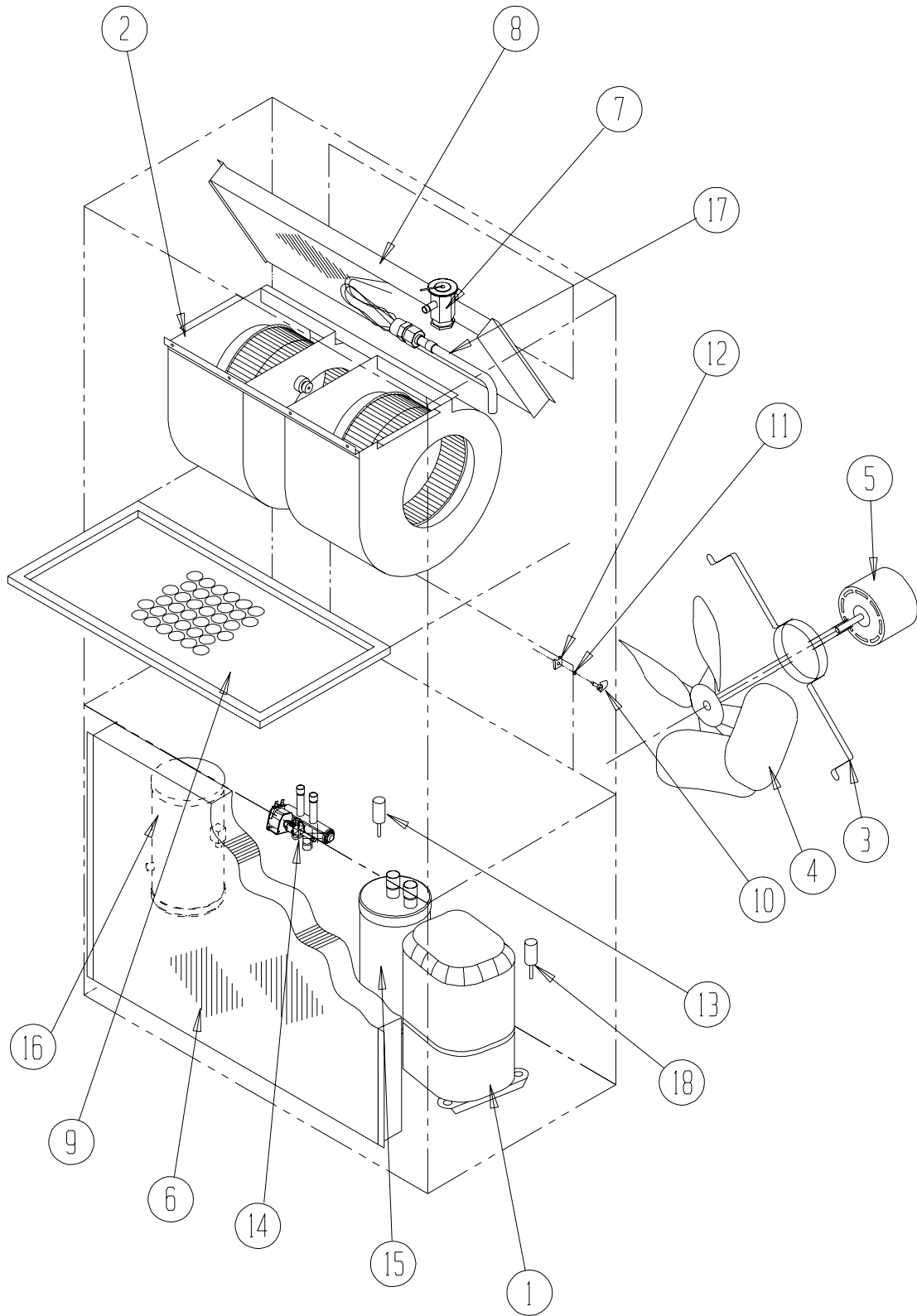

SEXP-589

This Exploded View references Table on Page 8

FUNCTIONAL COMPONENTS — LEFT HAND

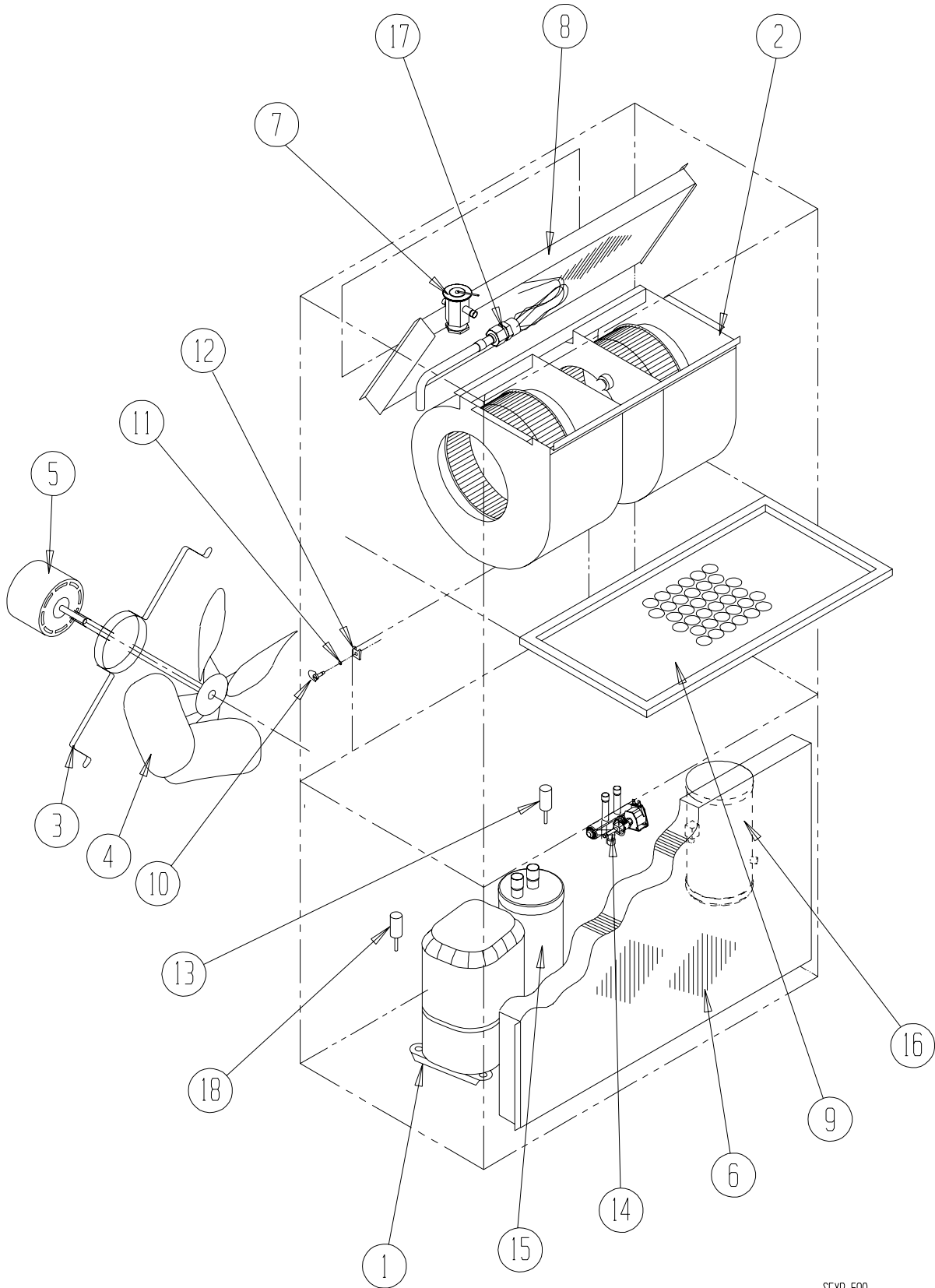

SEXP-590

This Exploded View references Table on Page 8

FUNCTIONAL COMPONENTS — RIGHT & LEFT HAND

Drawing No.	Part No.	Description	W5RV1-R	W5RV1-S	W5RV1-T	W5LV1-R	W5LV1-S	W5LV1-T
1	8000-352	Compressor	X			X		
1	8000-360	Compressor		X			X	
1	8000-361	Compressor			X			X
2	S900-273-009	Blower Assembly	X	X	X	X	X	X
3	8200-004	Fan Motor Mount	X	X	X	X	X	X
4	5151-027	Fan Blade	X	X	X	X	X	X
5	S8106-047-0080	1/2 HP ECM Motor with Programmed Control	X	X	X	X	X	X
5	C8106-047-0080	Programmed Motor Control - Only	X	X	X	X	X	X
6	5051-083BX	Condenser Coil	X	X	X			
6	5051-153BX	Condenser Coil				X	X	X
7	5651-215	Cooling TXV	X	X	X	X	X	X
8	5060-082BX	Evaporator Coil	X	X	X	X	X	X
9	7004-016	Air Filter 1" Throw-Away	X	X	X	X	X	X
9	7003-030	Air Filter 1" Washable ①	X	X	X	X	X	X
9	7004-027	Air Filter 2" Pleated ①	X	X	X	X	X	X
10	1171-022	1/4 Turn Fastener	X	X	X	X	X	X
11	1171-024	1/4 Turn Retainer	X	X	X	X	X	X
12	1171-023	1/4 Turn Receptacle	X	X	X	X	X	X
13	1804-0462	High Pressure Switch (Flare) - Red Leads	X	X	X	X	X	X
14	5650-049	Solenoid Valve	X	X	X	X	X	X
15	5202-018	Accumulator	X	X	X	X	X	X
16	5203-006	Receiver	X	X	X	X	X	X
17	800-0395	Cooling Distributor Assembly	X	X	X	X	X	X
18	1804-0107	Low Pressure Switch (Flare) - Blue Leads	X	X	X	X	X	X
NS	5201-002	Filter Drier	X	X	X	X	X	X
NS	8605-017	Crankcase Heater	X	X		X	X	
NS	8605-018	Crankcase Heater			X			X
NS	8408-039	Discharge Line Thermostat	X	X	X	X	X	X
NS	8406-128	Pressure Transducer	X	X	X	X	X	X

NS – Not Shown

① – Optional

This Table references Drawings on Pages 6 & 7

This page intentionally left blank.

CONTROL PANEL — RIGHT HAND

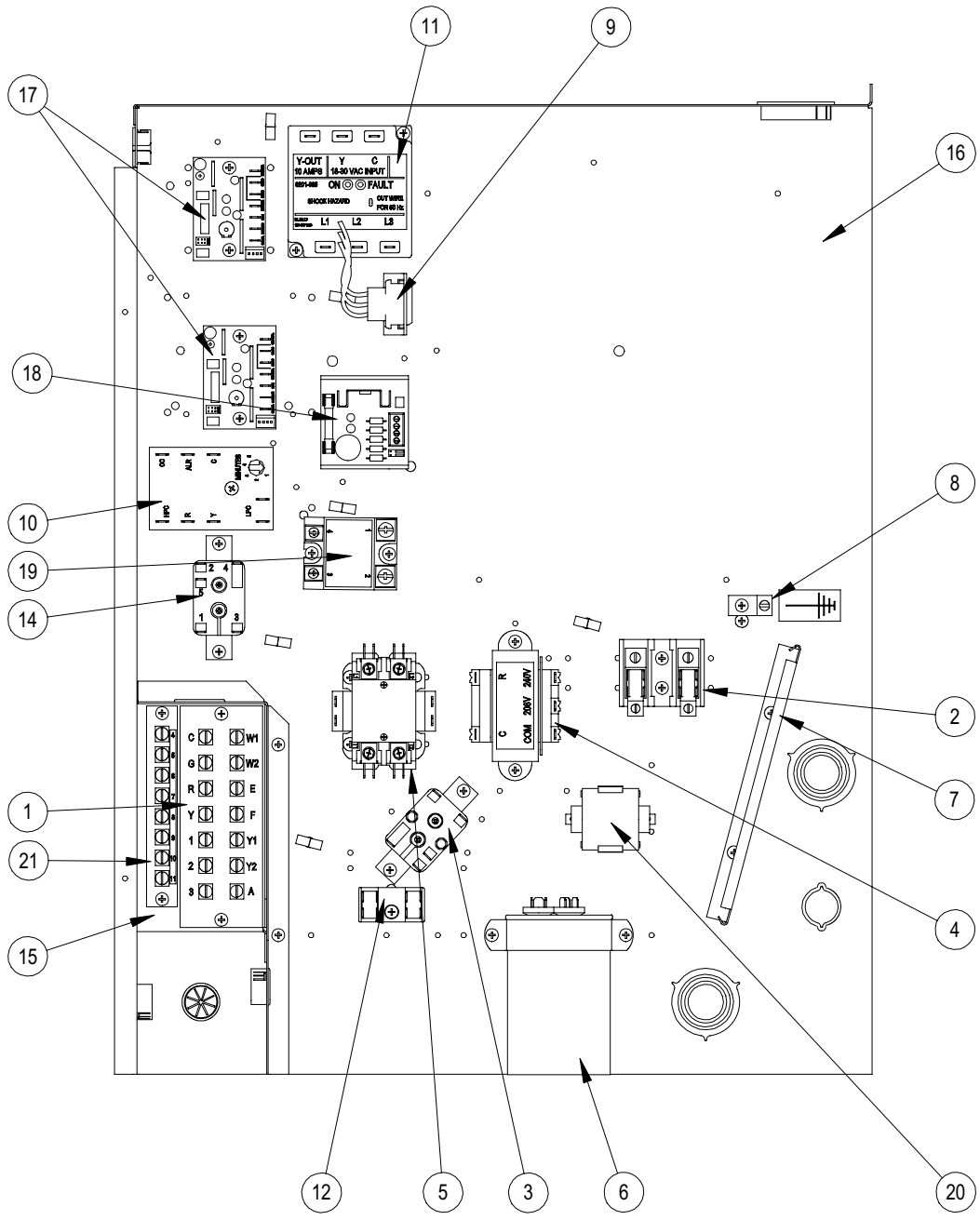

SEXP-591

This Exploded View references Table on Page 12

CONTROL PANEL — LEFT HAND

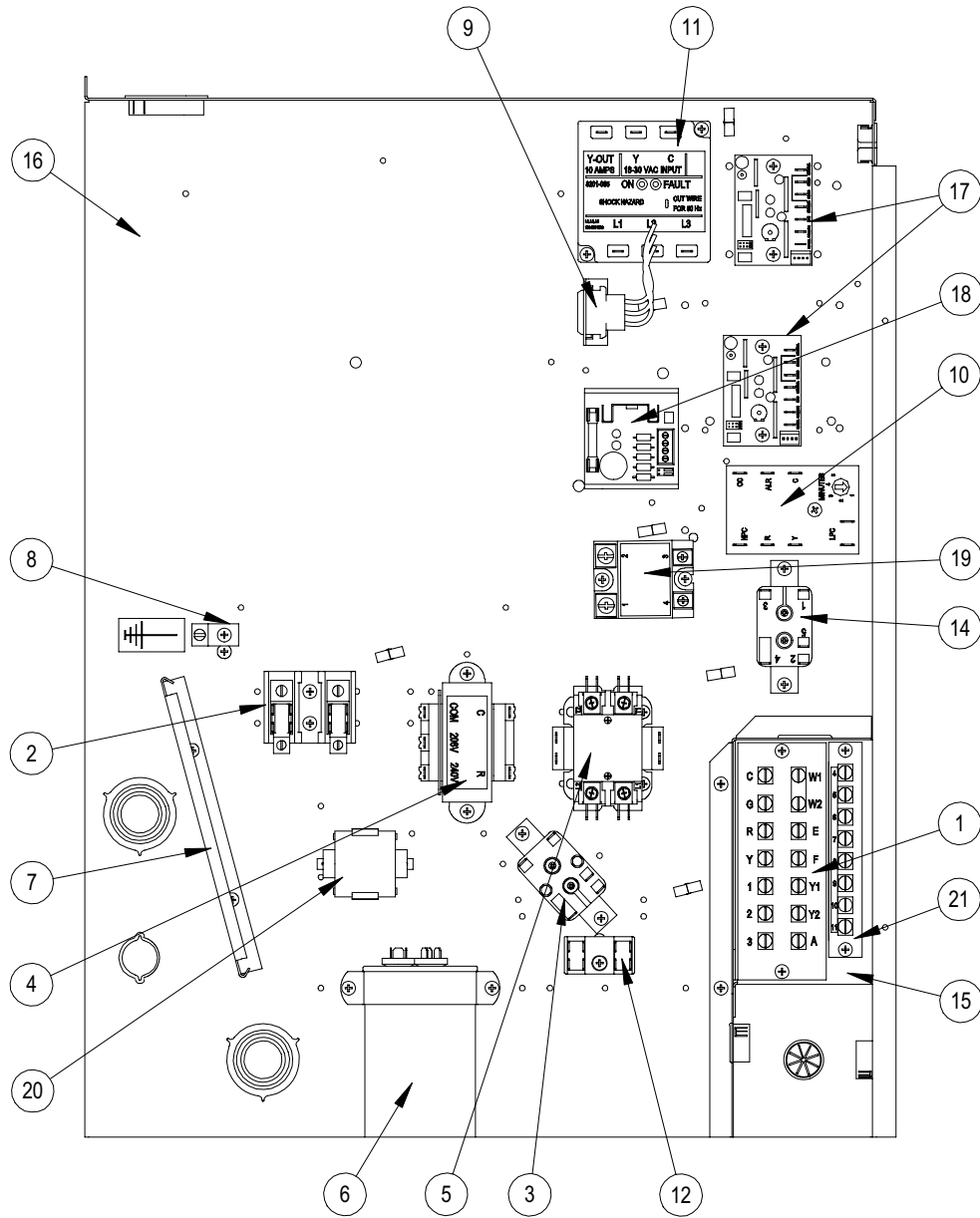

SEXP-592

This Exploded View references Table on Page 12

CONTROL PANEL — RIGHT & LEFT HAND

Drawing No.	Part No.	Description	W5RV1-R	W5RV1-S	W5RV1-T	W5LV1-R	W5LV1-S	W5LV1-T
1	8607-024	Low Voltage Terminal Strip	X	X	X	X	X	X
2	8607-013	Terminal Block 2 Pole	X			X		
2	8607-014	Terminal Block 3 Pole		X	X		X	X
2	8607-015	Phenolic Insulator			X			X
3	8201-009	Crankcase Heat Relay	X	X		X	X	
4	8407-048	Transformer	X	X		X	X	
4	8407-050	Transformer			X			X
5	8401-025	Compressor Contactor	X			X		
5	8401-027	Compressor Contactor		X	X		X	X
6	8552-092	Compressor Capacitor	X			X		
7	135-130	Wire Shield	X	X	X	X	X	X
8	8611-006	Ground Terminal	X	X	X	X	X	X
9	3000-1357	6 Pin Connector	X	X	X	X	X	X
10	8201-088	Compressor Control Module	X	X	X	X	X	X
11	8201-126	Phase Monitor		X	X		X	X
12	8607-017	Terminal Block			X			X
14	8201-062	Alarm Relay	X	X	X	X	X	X
15	S117X139	Low Voltage Box	X	X	X	X	X	X
16	117X143	Control Panel	X	X	X			
16	117Y143	Control Panel				X	X	X
17	8201-124	Blower Control Board	2	2	2	2	2	2
18	8301-041	5VDC Supply	X	X	X	X	X	X
19	8201-123	Solid State Relay	X	X	X	X	X	X
20	8551-004	Motor Starting Device	X			X		
21	8607-021	Terminal Strip (8 Terminal)	X	X	X	X	X	X
NS	8301-014	Outdoor Air Sensor	X	X	X	X	X	X
NS	8403-066	Thermostat Controller	X	X	X	X	X	X
NS	8614-041	Fuse Block			X			X
NS	8614-042	Fuses			X			X
NS	8615-041	Circuit Breaker 60A 2 Pole (Opt) ①	X			X		
NS	8615-043	Circuit Breaker 40A 3 Pole (Opt) ①		X			X	
NS	8615-068	Toggle Disconnect (Optional)			X			X
NS	3000-1221	Indoor Blower Power Harness	X	X	X	X	X	X
NS	3000-1358	Indoor Blower Low Voltage	X	X	X	X	X	X
NS	3000-1359	Outdoor Blower Low Voltage	X	X	X	X	X	X
NS	3000-1360	Pressure Transducer Harness	X	X	X	X	X	X
NS	3000-1224	Compressor Harness	X			X		
NS	3000-1231	Compressor Harness		X	X		X	X
NS	4095-157	Wiring Diagram	X			X		
NS	4095-254	Wiring Diagram		X			X	
NS	4095-354	Wiring Diagram			X			X

NS – Not Shown

① Circuit breakers listed are for units without electric heat "0Z" models. See Heater Replacement Parts Manual for units with electric heat.

This Table references Drawings on Pages 10 & 11

BLOWER ASSEMBLY

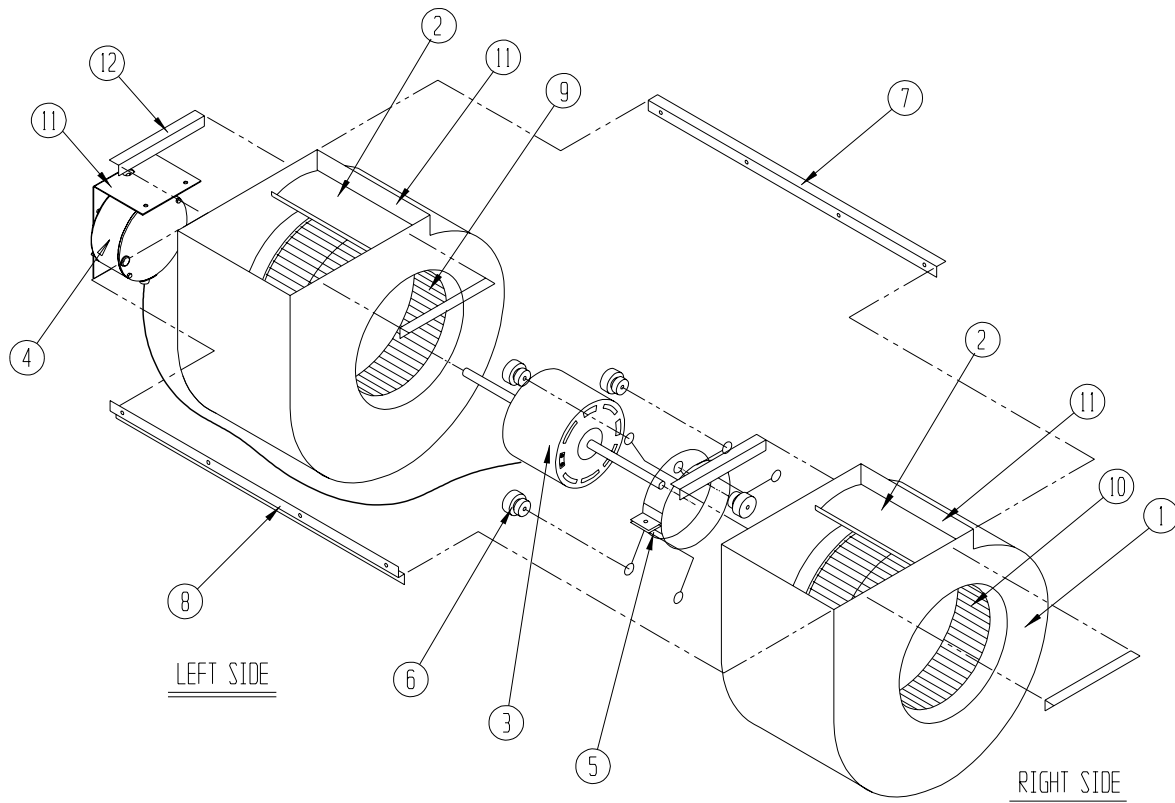

SEXP-593

900-273-009

Drawing No.	Part No.	Description	
1	151-101	Blower Housing	2
2	144-166	Diffuser	2
3	S8107-011-0079	Programmed Motor w/Control	X
4	C8107-011-0079	Programmed Motor Control-Only	X
5	8200-040	Motor Mount	X
6	5451-011	Grommets	6
7	105-881	Back Brace	X
8	103-389	Front Brace	X
9	5152-011	Wheel (CW)	X
10	5152-012	Wheel (CCW)	X
11	113-314	Blower Motor Control Mount	X
12	105-880	Blower Angle	4