REPLACEMENT PARTS MANUAL

WALL MOUNTED PACKAGE AIR CONDITIONER

Models:

W42A2-A	W48A2-A	W60A2-A	W70A2-A	W42A2DA	W48A2DA	W60A2DA
W42A2-B	W48A2-B	W60A2-B	W70A2-B	W42A2DB	W48A2DB	W60A2DB
W42A2-C	W48A2-C	W60A2-C	W70A2-C	W42A2DC	W48A2DC	W60A2DC
W42A2-E	W48A2-E	W60A2-E	W70A2-F			
W42A2-F	W48A2-F	W60A2-F				

Contents

Description	Page	Description	Page
Cabinet Components		Blower Assembly	
♦ Exploded View	2	♦ Exploded View	16
♦ Usage List	3	♦ Usage List	16
♦ Usage List	4		
Functional Components		General Notes	
♦ Exploded View	6	➤ Revised and/or additional pages may be issued from time to time.	
♦ Usage List	7	➤ A complete and current manual consists of pages shown in the following contents section.	
♦ Usage List	8		
♦ Usage List	9	Important	
Control Panel		➤ Contact the installing and/or local Bard distributor for all parts requirements. Make sure to have the complete model and serial number available from the unit rating plates.	
♦ Exploded View	10		
♦ Usage List	11		
♦ Usage List	12		
♦ Usage List	13		
Control Panel – Dehum. Models			
♦ Exploded View	14		
♦ Usage List	15		



Bard Manufacturing Company, Inc.
Bryan, Ohio 43506
www.bardvac.com

Manual: 2110-500M
Supersedes: 2110-500L
Date: 11-1-16

CABINET COMPONENTS

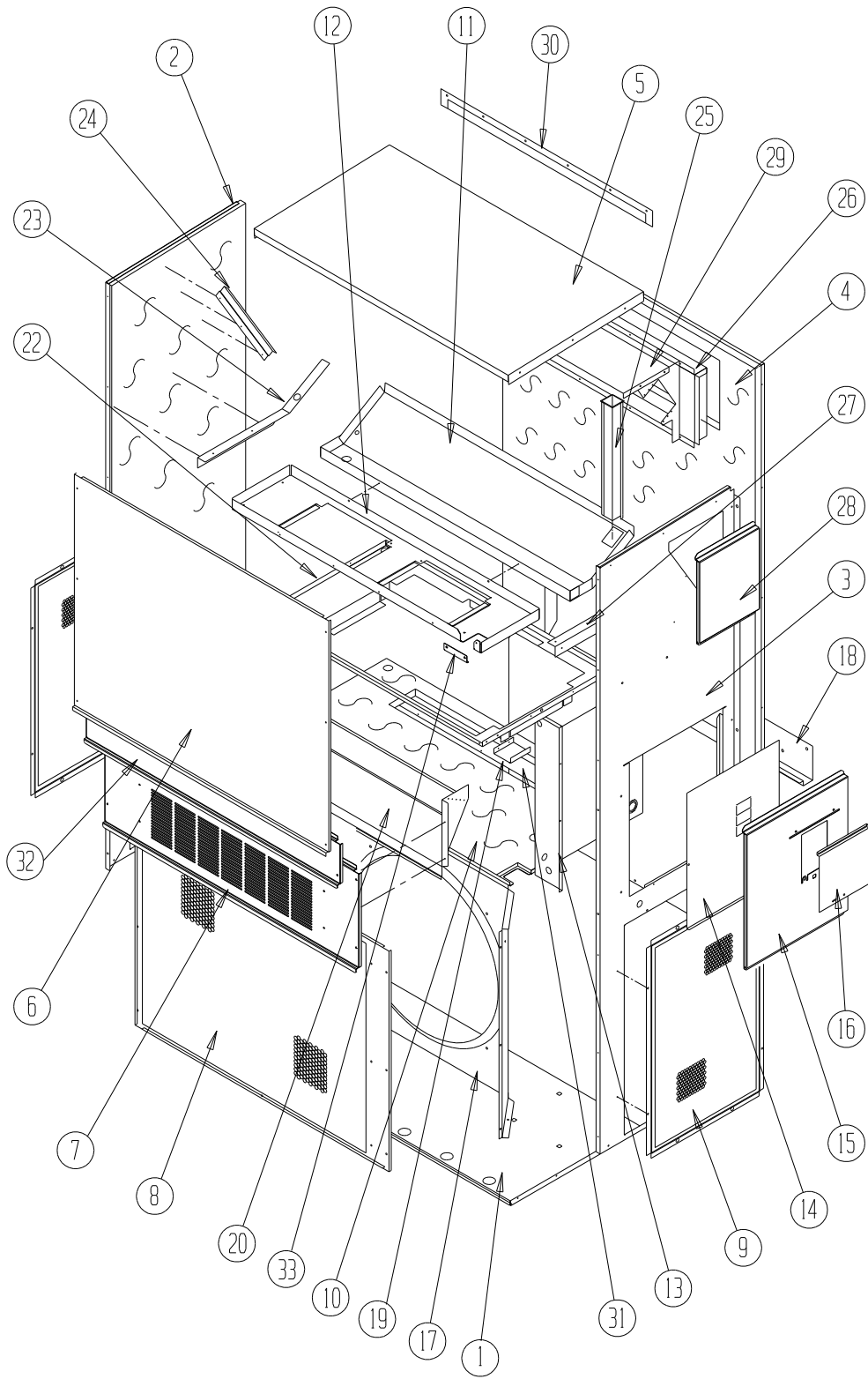

SEXP-658 A

This drawing is referenced in tables on pages 3 and 4

CABINET COMPONENTS

Dwg No.	Part Number	Description	W42A2-A, B, E	W42A2-C, F	W42A2DA, B	W42A2DC	W48A2-A, B, E	W48A2-C, F	W48A2DA, B	W48A2DC
1	127-425	Lower Base	X	X	X	X	X	X	X	X
1	127-430 ③	Lower Base	X	X	X	X	X	X	X	X
2	S501-686-* ①	Left Side	X	X	X	X	X	X	X	X
2	S501-699 ②	Left Side	X	X	X	X	X	X	X	X
2	S501-701 ③	Left Side	X	X	X	X	X	X	X	X
3	S501-677-* ①	Right Side	X	X	X	X	X	X	X	X
3	S501-698 ②	Right Side	X	X	X	X	X	X	X	X
3	S501-700 ③	Right Side	X	X	X	X	X	X	X	X
4	S508-098	Back	X	X	X	X	X	X	X	X
4	S508-275 ②	Back	X	X	X	X	X	X	X	X
4	S508-221 ③	Back	X	X	X	X	X	X	X	X
5	S507-307-* ①	Top	X	X	X	X	X	X	X	X
5	S507-309 ②	Top	X	X	X	X	X	X	X	X
5	S507-310 ③	Top	X	X	X	X	X	X	X	X
6	S515-230-* ①	Upper Front	X	X	X	X	X	X	X	X
6	S514-231 ②	Upper Front	X	X	X	X	X	X	X	X
6	S514-232 ③	Upper Front	X	X	X	X	X	X	X	X
7	S553-522-* ①	Vent Option Door	X	X	X	X	X	X	X	X
7	S553-529-* ①	Vent Option Door with ERV	X	X	X	X	X	X	X	X
7	S553-525 ②	Vent Option Door	X	X	X	X	X	X	X	X
7	S553-527 ③	Vent Option Door	X	X	X	X	X	X	X	X
8	118-048-* ①	Condenser Grille	X	X	X	X	X	X	X	X
8	118-064 ②	Condenser Grille	X	X	X	X	X	X	X	X
8	118-072 ③	Condenser Grille	X	X	X	X	X	X	X	X
9	118-057-* ①	Side Grille	2	2	2	2	2	2	2	2
9	118-063 ②	Side Grille	2	2	2	2	2	2	2	2
9	118-073 ③	Side Grille	2	2	2	2	2	2	2	2
10	S521X462	Condenser Partition	X	X	X	X	X	X	X	X
11	S123-122	Drain Pan	X	X	X	X	X	X	X	X
11	S123-125 ②③	Drain Pan	X	X	X	X	X	X	X	X
12	121X463	Blower Partition	X	X	X	X	X	X	X	X
13	Control Panel Assy.	See Control Panel Assy. Drawing & Parts List	X	X	X	X	X	X	X	X
14	S132-114	Control Panel Cover (Inner)	X		X		X		X	
14	S132-171	Control Panel Cover (Inner)		X		X		X		X
15	S533-225-* ①	Control Panel Cover (Outer)	X	X	X	X	X	X	X	X
15	S533-229 ②	Control Panel Cover (Outer)	X	X	X	X	X	X	X	X
15	S533-230 ③	Control Panel Cover (Outer)	X	X	X	X	X	X	X	X
16	S153-218-* ①	Disconnect Access Door	X	X	X	X	X	X	X	X
16	S153-387 ②	Disconnect Access Door	X	X	X	X	X	X	X	X
16	S153-405 ③	Disconnect Access Door	X	X	X	X	X	X	X	X
17	125-024	Fan Shroud	X	X	X	X	X	X	X	X
17	125-058 ③	Fan Shroud	X	X	X	X	X	X	X	X
18	113-140	Bottom Mounting Bracket	X	X	X	X	X	X	X	X
19	137-209	Fill	X	X	X	X	X	X	X	X
20	BFAD-5	Fresh Air Damper Assembly	X	X	X	X	X	X	X	X
22	131X099	Filter Tray	X	X	X	X	X	X	X	X
23	105X877	Left Side Support	X	X	X	X	X	X	X	X
24	147-046	Left Evaporator Support	X	X	X	X	X	X	X	X
25	135-128	Raceway	2	2	2	2	2	2	2	2
26	S111X034	Outlet Air Frame Assembly	X	X	X	X	X	X	X	X
27	105X878	Right Side Support	X	X	X	X	X	X	X	X
28	S543-172-* ①	Right Side Cover Plate (Outer)	X	X	X	X	X	X	X	X
28	S543-176 ②	Right Side Cover Plate (Outer)	X	X	X	X	X	X	X	X
28	S543-177 ③	Right Side Cover Plate (Outer)	X	X	X	X	X	X	X	X
29	135-129	Heat Shield	X	X	X	X	X	X	X	X
30	113-150-* ①	Top Rain Flashing	X	X	X	X	X	X	X	X
30	113-359 ③	Top Rain Flashing	X	X	X	X	X	X	X	X
31	S536-258	Cond. Partition Block Off Plate	X	X	X	X	X	X	X	X
32	S553-521-* ①	Filter Door Assembly	X	X	X	X	X	X	X	X
32	S553-526 ②	Filter Door Assembly	X	X	X	X	X	X	X	X
32	S553-528 ③	Filter Door Assembly	X	X	X	X	X	X	X	X
33	105-1302	Grommet Retainer	X	X	X	X	X	X	X	X

① Exterior cabinet parts are manufactured with various paint color options. To ensure the proper paint color is received, reference the following codes:
 Beige -X, White -1, Buckeye Gray -4, Desert Brown -5, Dark Bronze -8
 ② Exterior cabinet parts are manufactured from aluminum Code "A"
 ③ Exterior cabinet parts are manufactured from stainless steel Code "S"

CABINET COMPONENTS

Dwg No.	Part Number	Description	W60A2-A, B, E	W60A2-C, F	W60A2DA, B	W60A2DC	W70A2-A, B	W70A2-C, F
1	127-425	Lower Base	X	X	X	X	X	X
1	127-430 ③	Lower Base	X	X	X	X	X	X
2	S501-686-* ①	Left Side	X	X	X	X	X	X
2	S501-699 ②	Left Side	X	X	X	X	X	X
2	S501-701 ③	Left Side	X	X	X	X	X	X
3	S501-677-* ①	Right Side	X	X	X	X	X	X
3	S501-698 ②	Right Side	X	X	X	X	X	X
3	S501-700 ③	Right Side	X	X	X	X	X	X
4	S508-098	Back	X	X	X	X	X	X
4	S508-275 ②	Back	X	X	X	X	X	X
4	S508-221 ③	Back	X	X	X	X	X	X
5	S507-307-* ①	Top	X	X	X	X	X	X
5	S507-309 ②	Top	X	X	X	X	X	X
5	S507-310 ③	Top	X	X	X	X	X	X
6	S515-230-* ①	Upper Front	X	X	X	X	X	X
6	S514-231 ②	Upper Front	X	X	X	X	X	X
6	S514-232 ③	Upper Front	X	X	X	X	X	X
7	S553-522-* ①	Vent Option Door	X	X	X	X	X	X
7	S553-529-* ①	Vent Option Door with ERV	X	X	X	X	X	X
7	S553-525 ②	Vent Option Door	X	X	X	X	X	X
7	S553-527 ③	Vent Option Door	X	X	X	X	X	X
8	118-048-* ①	Condenser Grille	X	X	X	X	X	X
8	118-064 ②	Condenser Grille	X	X	X	X	X	X
8	118-072 ③	Condenser Grille	X	X	X	X	X	X
9	118-057-* ①	Side Grille	2	2	2	2	2	2
9	118-063 ②	Side Grille	2	2	2	2	2	2
9	118-073 ③	Side Grille	2	2	2	2	2	2
10	S521X462	Condenser Partition	X	X	X	X	X	X
11	S123-122	Drain Pan	X	X	X	X	X	X
11	S123-125 ②③	Drain Pan	X	X	X	X	X	X
12	121X463	Blower Partition	X	X	X	X	X	X
13	Control Panel Assy.	See Control Panel Assy. Drawing & Parts List	X	X	X	X	X	X
14	S132-114	Control Panel Cover (Inner)	X		X		X	
14	S132-171	Control Panel Cover (Inner)		X		X		X
15	S533-225-* ①	Control Panel Cover (Outer)	X	X	X	X	X	X
15	S533-229 ②	Control Panel Cover (Outer)	X	X	X	X	X	X
15	S533-230 ③	Control Panel Cover (Outer)	X	X	X	X	X	X
16	S153-218-* ①	Disconnect Access Door	X	X	X	X	X	X
16	S153-387 ②	Disconnect Access Door	X	X	X	X	X	X
16	S153-405 ③	Disconnect Access Door	X	X	X	X	X	X
17	125-024	Fan Shroud	X	X	X	X		
17	125-058 ③	Fan Shroud	X	X	X	X	X	X
17	125-085	Fan Shroud					X	X
18	113-140	Bottom Mounting Bracket	X	X	X	X	X	X
19	137-209	Fill	X	X	X	X	X	X
20	BFAD-5	Fresh Air Damper Assembly	X	X	X	X	X	X
22	131X099	Filter Tray	X	X	X	X	X	X
23	105X877	Left Side Support	X	X	X	X	X	X
24	147-046	Left Evaporator Support	X	X	X	X	X	X
25	135-128	Raceway	2	2	2	2	2	2
26	S111X034	Outlet Air Frame Assembly	X	X	X	X	X	X
27	105X878	Right Side Support	X	X	X	X	X	X
28	S543-172-* ①	Right Side Cover Plate (Outer)	X	X	X	X	X	X
28	S543-176 ②	Right Side Cover Plate (Outer)	X	X	X	X	X	X
28	S543-177 ③	Right Side Cover Plate (Outer)	X	X	X	X	X	X
29	135-129	Heat Shield	X	X	X	X	X	X
30	113-150-* ①	Top Rain Flashing	X	X	X	X	X	X
30	113-359 ③	Top Rain Flashing	X	X	X	X	X	X
31	S536-258	Cond. Partition Block Off Plate	X	X	X	X	X	X
32	S553-521-* ①	Filter Door Assembly	X	X	X	X	X	X
32	S553-526 ②	Filter Door Assembly	X	X	X	X	X	X
32	S553-528 ③	Filter Door Assembly	X	X	X	X	X	X
33	105-1302	Grommet Retainer	X	X	X	X	X	X

① Exterior cabinet parts are manufactured with various paint color options. To ensure the proper paint color is received, reference the following codes: Beige -X, White -1, Buckeye Gray -4, Desert Brown -5, Dark Bronze -8

② Exterior cabinet parts are manufactured from aluminum Code "A"

③ Exterior cabinet parts are manufactured from stainless steel Code "S"

This page intentionally left blank

FUNCTIONAL COMPONENTS

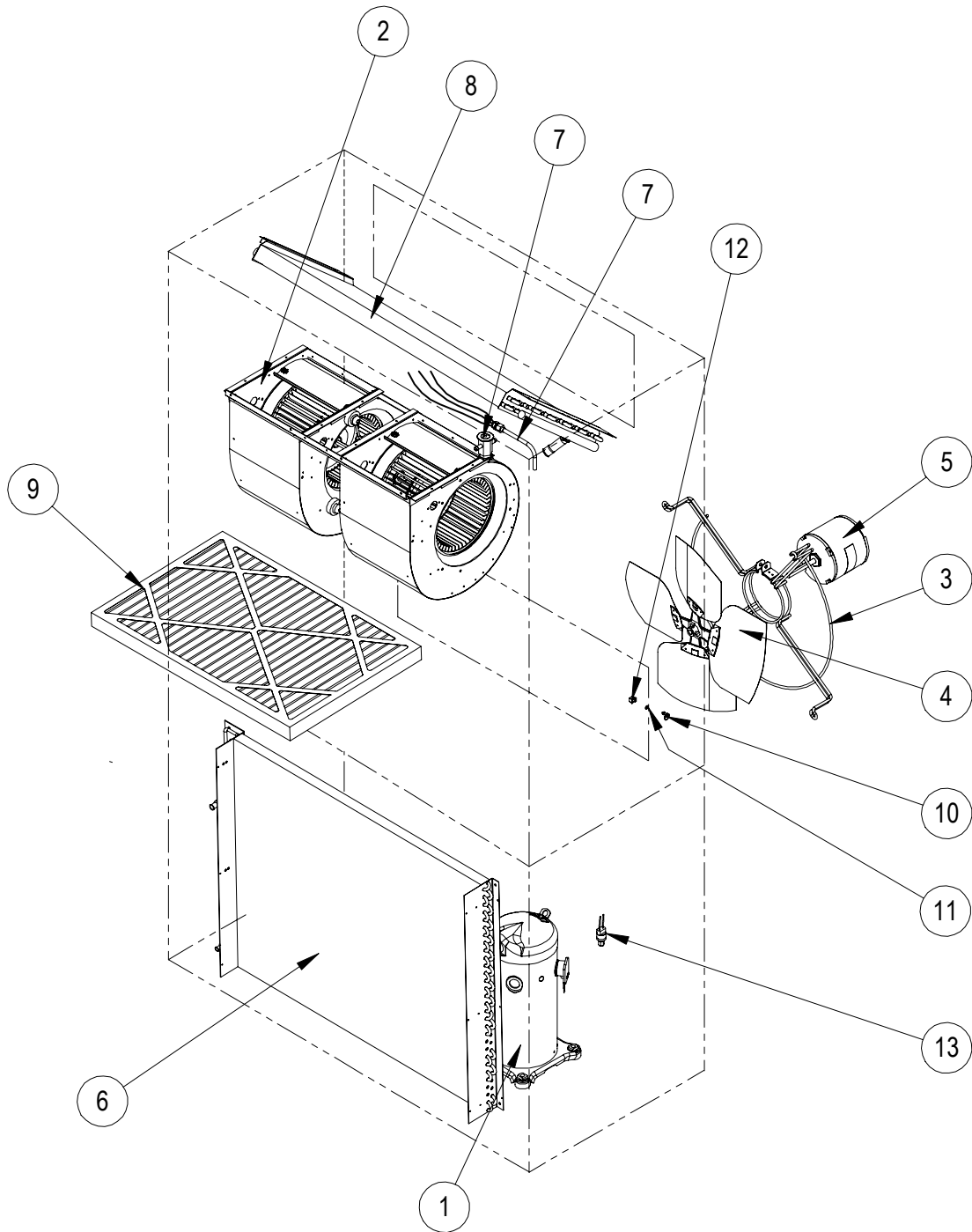

SEXP-177 A

This drawing is referenced in tables on pages 7, 8 and 9

FUNCTIONAL COMPONENTS

Dwg No.	Part Number	Description	W42A2-A	W42A2-B, E	W42A2-C	W42A2-F	W42A2DA	W42A2DB	W42A2DC
1	8000-318	Compressor	X				X		
1	8000-319	Compressor		X				X	
1	8000-320	Compressor			X	X			X
2	S900-320	Blower Assembly	X	X		X	X	X	
2	S900-321	Blower Assembly			X				X
3	8200-004	Fan Motor Mount	X	X	X	X	X	X	X
4	5151-060	Fan Blade	X	X	X	X	X	X	X
5	8105-030	Condenser Motor			X				X
5	8105-039	Condenser Motor	X	X		X	X	X	
6	5051-179BX	Condenser Coil	X	X	X	X	X	X	X
7	5651-208	Expansion Valve Assembly					X	X	X
7	800-0420	Distributor Assembly	X	X	X	X			
7	800-0421	Distributor Assembly					X	X	X
8	917-0205BX	Evaporator Coil					X	X	X
8	917-0206BX	Evaporator Coil	X	X	X	X			
9	7004-016	Air Filter 1" Throw-Away	X	X	X	X	X	X	X
9	7003-030	Air Filter 1" Washable	X	X	X	X	X	X	X
9	7004-027	Air Filter 2" Pleated	X	X	X	X	X	X	X
10	1171-022	1/4 Turn Fastener	X	X	X	X	X	X	X
11	1171-024	1/4 Turn Retainer	X	X	X	X	X	X	X
12	1171-023	1/4 Receptacle	X	X	X	X	X	X	X
13	1804-0385	High Pressure Switch (Flare)	X	X	X	X	X	X	X
13	1804-0386	Low Pressure Switch (Flare)	X	X	X	X	X	X	X
NS	5201-022	Filter Drier	X	X	X	X	X	X	X
NS	5650-042	Rev. Valve Solenoid, Red Casing (Ranco)					X	X	X
NS	5650-046	Rev. Valve Solenoid, Black Casing (San Hua)					X	X	X
NS	5650-051	Dehum. Valve 4-Pipe 1/2 x 1/2 with 24V Solenoid Coil					X	X	X
NS	5651-219	Check Valve					2	2	2
NS	CMA-28	Low Ambient Control (Flare) ①	X	X	X	X			
NS	CMA-32	Low Ambient Control (Flare) ①					X	X	
NS	CMA-34	460V Modulating Low Ambient Control ①							X
NS	5451-024	Tubing Isolation Grommet	2	2	2	2	2	2	2
NS	6031-009	Coremax Valve Core	X	X	X	X	X	X	X

NS – Not Shown

① – Optional on these models

FUNCTIONAL COMPONENTS

Dwg No.	Part Number	Description	W48A2-A	W48A2-B, E	W48A2-C	W48A2-F	W48A2DA	W4828DB	W48A2DC	W60A2-A	W60A2-B, E	W60A2-C	W60A2-F	W60A2DA	W60A2DB	W60A2DC
1	8000-324	Compressor							X					X		
1	8000-325	Compressor		X						X					X	
1	8000-401	Compressor			X	X		X								
1	8000-402	Compressor							X							
1	8000-400	Compressor	X				X									
1	8000-326	Compressor										X	X			X
2	S900-320	Blower Assembly	X	X		X	X	X								
2	S900-321	Blower Assembly			X				X							
2	S900-185	Blower Assembly							X	X					X	
2	S900-186	Blower Assembly									X					X
3	8200-004	Fan Motor Mount	X	X	X	X	X	X	X	X	X	X	X	X	X	X
4	5151-060	Fan Blade	X	X	X	X	X	X	X	X	X	X	X	X	X	X
5	8105-030	Condenser Motor			X			X				X				X
5	8105-039	Condenser Motor	X	X		X	X	X	X	X		X	X	X	X	
6	5051-179BX	Condenser Coil	X	X	X	X	X	X								
6	5051-180BX	Condenser Coil							X	X	X	X	X	X	X	X
7	800-0422	Distributor Assembly	X	X	X	X										
7	800-0421	Distributor Assembly					X	X	X							
7	800-0423	Distributor Assembly								X	X	X	X			
7	800-0430	Distributor Assembly													X	X
7	5651-223	Expansion Valve					X	X	X						X	X
7	5651-241	Expansion Valve												X	X	X
8	917-0207BX	Evaporator Coil	X	X	X	X										
8	917-0208BX	Evaporator Coil							X	X	X	X				
8	917-0205BX	Evaporator Coil					X	X	X							
8	917-0203BX	Evaporator Coil												X	X	X
9	7004-016	Air Filter 1" Throw-Away	X	X	X	X	X	X	X	X	X	X	X	X	X	X
9	7003-030	Air Filter 1" Washable	X	X	X	X	X	X	X	X	X	X	X	X	X	X
9	7004-027	Air Filter 2" Pleated	X	X	X	X	X	X	X	X	X	X	X	X	X	X
10	1171-022	1/4 Turn Fastener	X	X	X	X	X	X	X	X	X	X	X	X	X	X
11	1171-024	1/4 Turn Retainer	X	X	X	X	X	X	X	X	X	X	X	X	X	X
12	1171-023	1/4 Receptacle	X	X	X	X	X	X	X	X	X	X	X	X	X	X
13	1804-0385	High Pressure Switch (Flare)	X	X	X	X	X	X	X	X	X	X	X	X	X	X
13	1804-0386	Low Pressure Switch (Flare)	X	X	X	X	X	X	X	X	X	X	X	X	X	X
NS	5201-022	Filter Drier	X	X	X	X	X	X	X	X	X	X	X	X	X	X
NS	5650-042	Rev. Valve Solenoid, Red Casing (Ranco)					X	X	X					X	X	X
NS	5650-046	Rev. Valve Solenoid, Black Casing (San Hua)					X	X	X					X	X	X
NS	5650-051	Dehum. Valve 4-Pipe 1/2 x 1/2 with 24V Solenoid Coil					X	X	X					X	X	X
NS	CMA-28	Low Ambient Control (Flare) ①	X	X	X	X				X	X	X	X			
NS	CMA-32	Low Ambient Control (Flare) ①					X	X						X	X	
NS	CMA-34	460V Modulating Low Ambient Control ①						X								X
NS	5651-219	Check Valve					2	2	2					2	2	2
NS	5451-024	Tubing Isolation Grommet	2	2	2	2	2	2	2	2	2	2	2	2	2	2
NS	6031-009	Coremax Valve Core	X	X	X	X	X	X	X	X	X	X	X	X	X	X

NS – Not Shown

① – Optional on these models

This table references drawing on page 6

FUNCTIONAL COMPONENTS

Dwg No.	Part Number	Description	W70A2-A	W70A2-B	W70A2-C	W70A2-F
1	8000-403	Compressor	X			
1	8000-404	Compressor		X		
1	8000-405	Compressor			X	X
2	S900-185	Blower Assembly	X	X		X
2	S900-186	Blower Assembly			X	
3	8200-049	Fan Motor Mount	X	X	X	X
4	5151-062	Fan Blade	X	X	X	X
5	8106-067	Condenser Motor			X	
5	8106-016	Condenser Motor	X	X		X
6	5051-180BX	Condenser Coil	X	X	X	X
7	800-0425	Distributor Assembly	X	X	X	X
8	917-0209BX	Evaporator Coil	X	X	X	X
9	7004-016	Air Filter 1" Throw-Away	X	X	X	X
9	7003-030	Air Filter 1" Washable	X	X	X	X
9	7004-027	Air Filter 2" Pleated	X	X	X	X
10	1171-022	1/4 Turn Fastener	X	X	X	X
11	1171-024	1/4 Turn Retainer	X	X	X	X
12	1171-023	1/4 Receptacle	X	X	X	X
NS	5201-022	Filter Drier	X	X	X	X
NS	CMA-28	Low Ambient Control (Flare) ①	X	X	X	X
NS	1804-0385	High Pressure Switch (Flare)	X	X	X	X
NS	1804-0386	Low Pressure Switch (Flare)	X	X	X	X
NS	5451-024	Tubing Isolation Grommet	2	2	2	2
NS	CMC-29	Freeze Thermostat Kit	X	X	X	X
NS	6031-009	Coremax Valve Core	X	X	X	X

NS – Not Shown

① – Optional on these models

This table references drawing on page 6

CONTROL PANEL

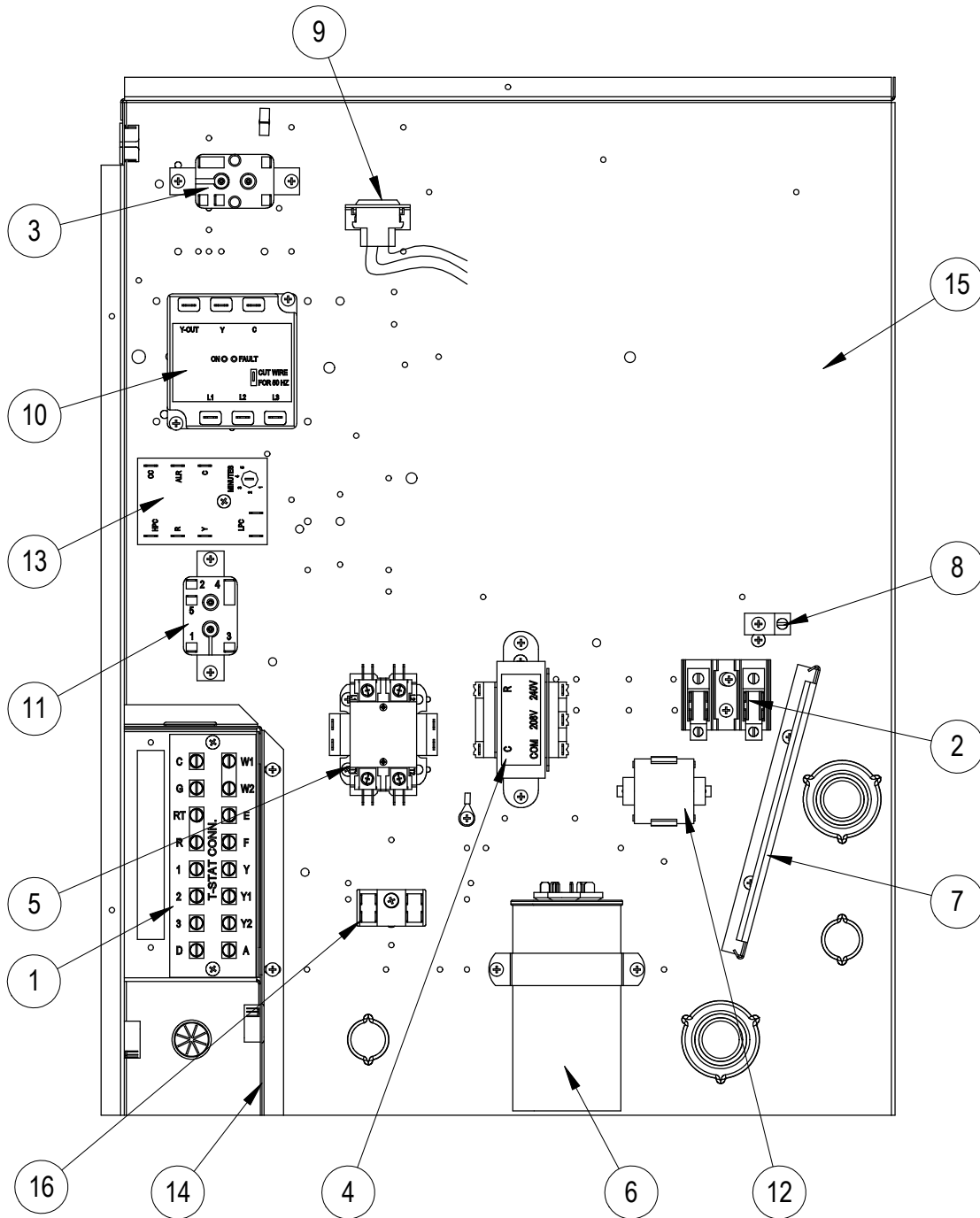

SEXP-659

This drawing is referenced in tables on pages 11, 12 and 13

CONTROL PANEL

Dwg No.	Part Number	Description	W42A2-A	W42A2-B	W42A2-C	W42A2-E	W42A2-F	W48A2-A	W48A2-B	W48A2-C	W48A2-E	W48A2-F
1	8607-034	Low Voltage Terminal Strip	X	X	X	X	X	X	X	X	X	X
2	8607-013	Terminal Block 2 Pole	X				2	X				2
2	8607-014	Terminal Block 3 Pole		X	X	X			X		X	
2	8607-015	Phenolic Insulator			X					X		
3	8201-009	Blower Control Relay	X	X		X	X	X	X		X	X
3	8201-032	Blower Control Relay			X					X		
4	8407-034	Transformer	X	X		X	X	X	X		X	X
4	8407-042	Transformer			X					X		
5	8401-002	Compressor Contactor		X	X	X	X		X	X	X	X
5	8401-025	Compressor Contactor	X					X				
6	8552-005	Outdoor Motor Capacitor		X		X	X		X		X	X
6	8552-026	Outdoor Motor Capacitor			X					X		
6	8552-079	Compressor Capacitor	X									
6	8552-089	Compressor Capacitor						X				
7	135-130	Wire Shield	X	X	X	X	X	X	X	X	X	X
8	8611-006	Ground Terminal	X	X	X	X	X	X	X	X	X	X
9	3000-1017	6 Pin Connector	X	X	X	X	X	X	X	X	X	X
10	8201-126	Phase Monitor		X	X	X	X		X	X	X	X
11	8201-062	Alarm Relay ①	X	X	X	X	X	X	X	X	X	X
12	8551-004	Start Device	X					X				
13	8201-148	Compressor Control Module	X	X	X	X	X	X	X	X	X	X
14	117X333	Low Voltage Box	X	X	X	X	X	X	X	X	X	X
15	117X340	Control Panel	X	X	X	X	X	X	X	X	X	X
16	8607-017	Terminal Block ①	X	X	X	X	X	X	X	X	X	X
NS	8615-040	Circuit Breaker 50A 2 Pole ②	X					X				
NS	8615-042	Circuit Breaker 35A 3 Pole ②		X		X			X		X	
NS	8615-067	Toggle Disconnect ②			X		X			X		X
NS	4095-163	Wiring Diagram	X					X				
NS	4095-255	Wiring Diagram		X					X			
NS	4095-357	Wiring Diagram			X					X		
NS	4095-256	Wiring Diagram				X					X	
NS	4095-635	Wiring Diagram					X					X

① Optional on these models.

② Circuit breakers listed are for units without electric heat "OZ" models. See heater replacement parts manual for units with electric heat.

NS – Not Shown

CONTROL PANEL

Dwg No.	Part Number	Description	W60A2-A	W60A2-B	W60A2-C	W60A2-E	W60A2-F
1	8607-034	Low Voltage Terminal Strip	X	X	X	X	X
2	8607-013	Terminal Block 2 Pole	X				2
2	8607-014	Terminal Block 3 Pole		X	X	X	
2	8607-015	Phenolic Insulator			X		
3	8201-009	Blower Control Relay	X	X		X	X
3	8201-032	Blower Control Relay			X		
4	8407-034	Transformer	X	X		X	X
4	8407-042	Transformer			X		
5	8401-002	Compressor Contactor		X	X	X	X
5	8401-025	Compressor Contactor	X				
6	8552-058	Compressor Capacitor	X				
6	8552-005	Outdoor Motor Capacitor		X			
6	8552-026	Outdoor Motor Capacitor			X		
6	8552-005	Outdoor Motor Capacitor				X	X
7	135-130	Wire Shield	X	X	X	X	X
8	8611-006	Ground Terminal	X	X	X	X	X
9	3000-1017	6 Pin Connector	X	X	X	X	X
10	8201-126	Phase Monitor		X	X	X	X
11	8201-062	Alarm Relay ①	X	X	X	X	X
12	8551-004	Start Device (PTCR) ①	X				
13	8201-148	Compressor Control Module	X	X	X	X	X
14	117X333	Low Voltage Box	X	X	X	X	X
15	117X340	Control Panel	X	X	X	X	X
16	8607-017	Terminal Block ①	X	X	X	X	X
NS	8615-041	Circuit Breaker 60A 2 Pole ②	X				
NS	8615-043	Circuit Breaker 40A 3 Pole ②		X		X	
NS	8615-067	Toggle Disconnect ②			X		X
NS	4095-163	Wiring Diagram	X				
NS	4095-255	Wiring Diagram		X			
NS	4095-357	Wiring Diagram			X		
NS	4095-256	Wiring Diagram				X	
NS	4095-635	Wiring Diagram					X

① Optional on these models.

② Circuit breakers listed are for units without electric heat "OZ" models. See heater replacement parts manual for units with electric heat.

NS – Not Shown

This table references drawing on page 10

CONTROL PANEL

Dwg No.	Part Number	Description	W70A2-A	W70A2-B	W70A2-C	W70A2-F
1	8607-034	Low Voltage Terminal Strip	X	X	X	X
2	8607-013	Terminal Block 2 Pole	X			2
2	8607-014	Terminal Block 3 Pole		X	X	
2	8607-015	Phenolic Insulator			X	
3	8201-009	Blower Control Relay	X	X		X
3	8201-032	Blower Control Relay			X	
4	8407-034	Transformer	X	X		X
4	8407-042	Transformer			X	
5	8401-002	Compressor Contactor		X	X	X
5	8401-025	Compressor Contactor	X			
6	8552-082	Compressor Capacitor	X			
6	8552-004	Outdoor Motor Capacitor		X		
6	8552-005	Outdoor Motor Capacitor			X	X
7	135-130	Wire Shield	X	X	X	X
8	8611-006	Ground Terminal	X	X	X	X
9	3000-1017	6 Pin Connector	X	X	X	X
10	8201-126	Phase Monitor		X	X	X
11	8201-062	Alarm Relay ①	X	X	X	X
12	8551-004	Start Device (PTCR) ①	X			
13	8201-148	Compressor Control Module	X	X	X	X
14	117X333	Low Voltage Box	X	X	X	X
15	117X340	Control Panel	X	X	X	X
16	8607-017	Terminal Block ①	X	X	X	X
NS	8615-041	Circuit Breaker 60A 2 Pole ②	X			
NS	8615-045	Circuit Breaker 50A 3 Pole ②		X		
NS	8615-067	Toggle Disconnect ②			X	X
NS	4095-165	Wiring Diagram	X			
NS	4095-257	Wiring Diagram		X		
NS	4095-358	Wiring Diagram			X	
NS	4095-259	Wiring Diagram				X

① Optional on these models.

② Circuit breakers listed are for units without electric heat "OZ" models. See heater replacement parts manual for units with electric heat.

NS – Not Shown

This table references drawing on page 10

CONTROL PANEL - DEHUM. MODELS

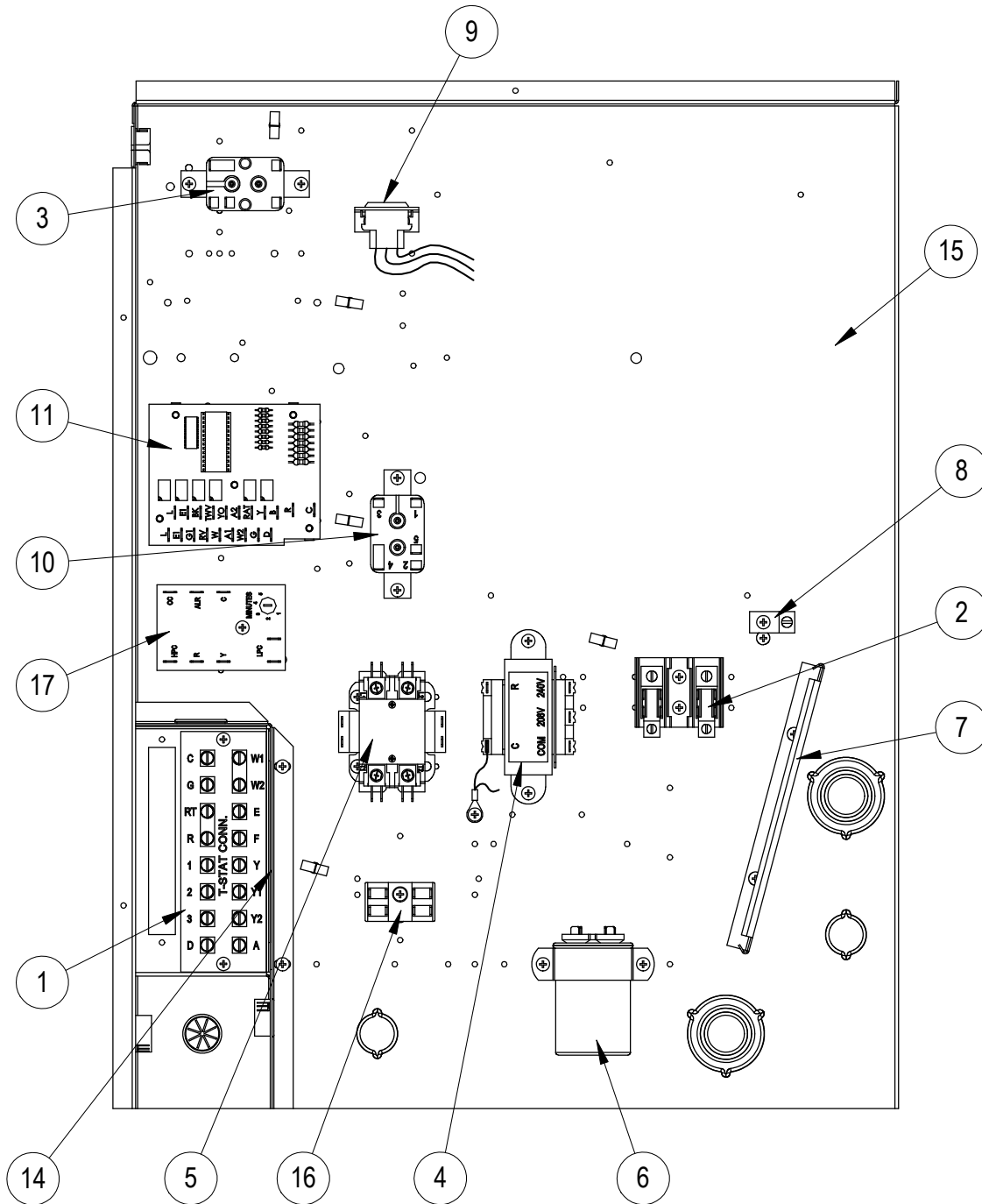

SEXP-660

CONTROL PANEL – DEHUM. MODELS

Dwg No.	Part Number	Description	W42A2DA	W42A2DB	W42A2DC	W48A2DA	W48A2DB	W48A2DC	W60A2DA	W60A2DB	W60A2DC
1	8607-034	Low Voltage Terminal Strip	X	X	X	X	X	X	X	X	X
2	8607-013	Terminal Block 2 Pole	X			X			X		
2	8607-014	Terminal Block 3 Pole		X	X		X	X		X	X
2	8607-015	Phenolic Insulator			X			X			X
3	8201-009	Blower Control Relay	X	X		X	X		X	X	
3	8201-032	Blower Control Relay			X			X			X
4	8407-035	Transformer	X	X		X	X		X	X	
4	8407-042	Transformer			X			X			X
5	8401-002	Compressor Contactor		X	X		X	X		X	X
5	8401-025	Compressor Contactor	X			X			X		
6	8552-079	Compressor Capacitor 45/10 MFD-370V	X								
6	8552-005	Outdoor Motor Capacitor 10 MFD-370V		X			X				
6	8552-026	Outdoor Motor Capacitor 15 MFD-370V			X			X			X
6	8552-089	Compressor Capacitor 70/10 MFD-370V				X					
6	8552-058	Compressor Capacitor 80/10 MFD-440V							X		
6	8552-004	Outdoor Motor Capacitor 7.5 MFD-370V								X	
7	135-130	Wire Shield	X	X	X	X	X	X	X	X	X
8	8611-006	Ground Terminal	X	X	X	X	X	X	X	X	X
9	3000-1017	6 Pin Connector	X	X	X	X	X	X	X	X	X
10	8201-062	Relay	X	X	X	X	X	X	X	X	X
11	8201-113	Logic Board	X	X	X	X	X	X	X	X	X
14	117X333	Low Voltage Box	X	X	X	X	X	X	X	X	X
15	117X340	Control Panel	X	X	X	X	X	X	X	X	X
16	8607-017	Terminal Block (Optional)	X	X	X	X	X	X	X	X	X
17	8201-148	Compressor Control Module	X	X	X	X	X	X	X	X	X
NS	8615-040	Circuit Breaker 50A 2 Pole ①	X			X					
NS	8615-042	Circuit Breaker 35A 3 Pole ①		X			X				
NS	8615-067	Toggle Disconnect ①			X			X			X
NS	8615-041	Circuit Breaker 60A 2 Pole ①							X		
NS	8615-044	Circuit Breaker 45A 3 Pole ①								X	
NS	4095-164	Wiring Diagram	X			X			X		
NS	4095-258	Wiring Diagram		X			X			X	
NS	4095-359	Wiring Diagram			X			X			X

① Circuit breakers listed are for units without electric heat "OZ" models. See heater replacement parts manual for units with electric heat.

NS – Not Shown

BLOWER ASSEMBLY

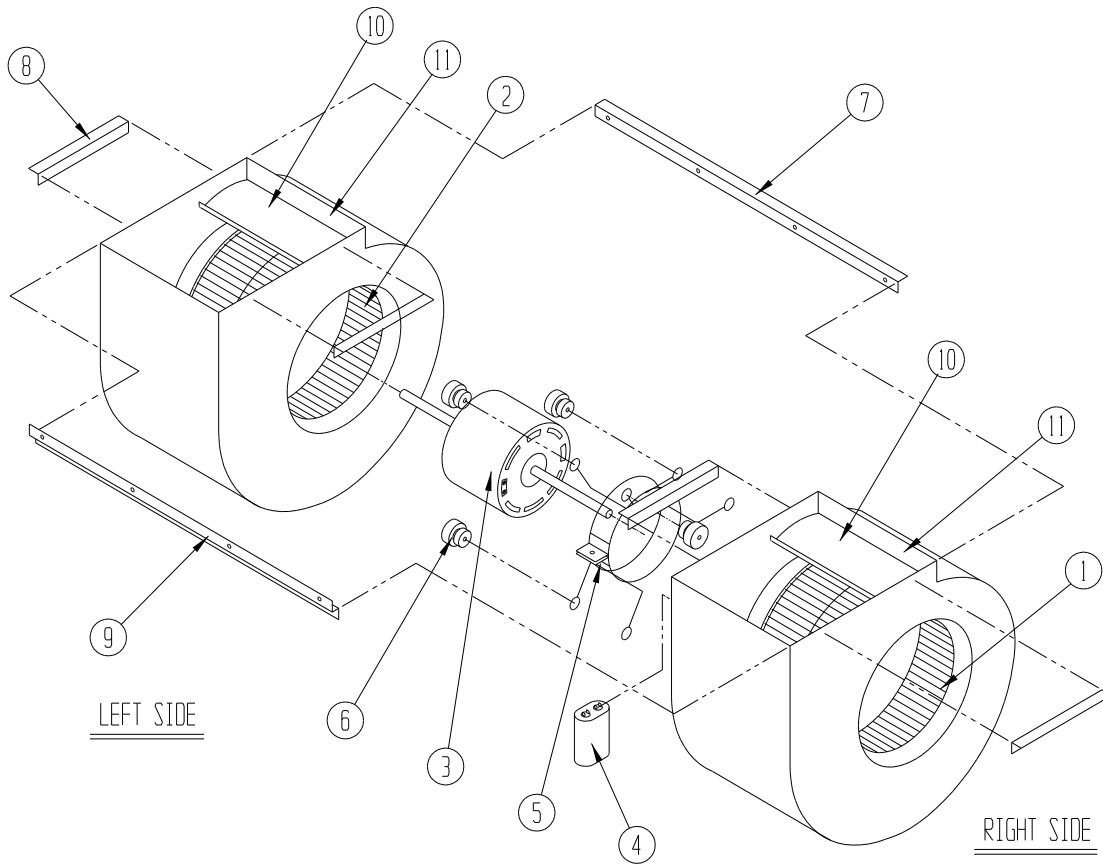

SEXP-178

Dwg No.	Part Number	Description	900-320	900-321	900-185	900-186
1	5152-011	10 Inch Wheel (CW)			X	X
1	5152-057	9 Inch Wheel (CW)	X	X		
2	5152-012	10 Inch Wheel (CW)			X	X
2	5152-058	9 Inch Wheel (CW)	X	X		
3	8105-061	Blower Motor (230/208)	X			
3	8105-062	Blower Motor (460)		X		
3	8106-046	Blower Motor (230/208)			X	
3	8106-025	Blower Motor (460)				X
4	8552-091	Capacitor	X	X	X	
4	8552-005	Capacitor				X
5	8200-040	Motor Mount	X	X	X	X
6	5451-011	Grommets	6	6	6	6
7	105-881	Back Brace	X	X	X	X
8	105-880	Side Angle	4	4	4	4
9	103-389	Front Brace	X	X	X	X
10	151-101	Housing	2	2	2	2
11	144-166	Diffuser	2	2	2	2