

# REPLACEMENT PARTS MANUAL

## WALL MOUNTED PACKAGE HEAT PUMP MODEL 24WH6

Manual 2110-502

Revision B

Date 8-23-90

Supersedes 1-25-90

\*\*\*\*\*  
\* GENERAL NOTES \*  
\*\*\*\*\*

\*Revised and/or additional pages may be issued from time to time.  
\*A complete and current manual consists of pages dated as shown in the following index.

\*\*\*\*\*  
\*\* INDEX \*\*  
\*\*\*\*\*

<u>Page Description</u>	<u>Page</u>	<u>Date</u>	<u>Supersedes</u>
Cabinet Components--Exploded View	1	7-11-89	
" " --Usage List	2	1-25-90	
Functional Components--Exploded View	3	7-11-89	
" " --Usage List	4	8-23-90	7-11-89
Control Panel--Layout	5	7-11-89	
" " --Usage List	6	7-11-89	
Blower Assembly--Exploded View	7	7-11-89	
" " --Usage List	8	7-11-89	

\*\*\*\*\*  
\*\*\* IMPORTANT \*\*\*  
\*\*\*\*\*

Contact the installing and/or local Bard distributor for all parts requirements. Make sure you have the complete model and serial number available from the unit rating plate.

CABINET COMPONENTS

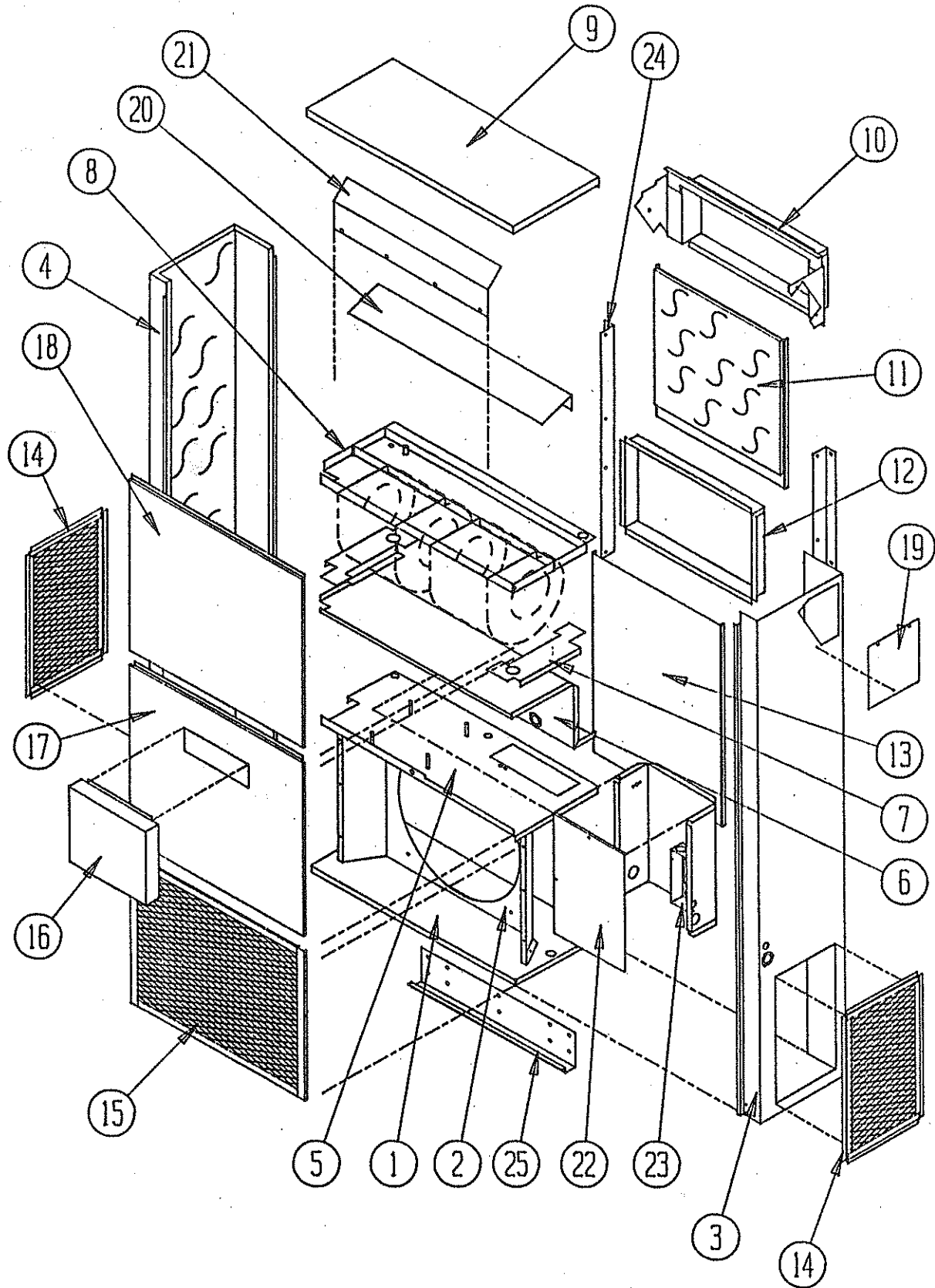

Date: 7-11-89  
Supersedes:

CABINET COMPONENTS

Item No.	Part No.	Description	U S A G E
1	126-001	Lower Base	X
2	124-001	Fan Shroud	X
3	501-162	Right Side Assembly	X
4	501-163	Left Side Assembly	X
5	127-103	Compressor Base	X
6	520-096	Compressor Partition	X
7	130-001	Filter Support	X
8	121-089	Water Pan Assembly	X
9	506-094	Top	X
10	111-015	Supply Air Frame	X
11	508-054	Upper Back	X
12	111-016	Inlet Air Frame	X
13	108-055	Lower Back	X
14	119-002	Side Condenser Grille	X
15	119-001	Front Condenser Grille	X
16	962001	Fresh Air Damper	X
17	552-106	Service Door	X
18	514-045	Upper Front	X
19	542-001	Side Cover Plate	X
20	136-112	Evaporator Bottom Support Fill	X
21	134-004	Air Baffle	X
22	Control Panel Cvr	See Control Panel Assembly Drawing and Parts List	X
23	Control Panel Asy	See Control Panel Assembly Drawing and Parts List	X
24	112-002	Side Mounting Bracket	X
25	112-001	Bottom Support Bracket	X

Date: 1-25-90  
Supersedes: 7-11-89

FUNCTIONAL COMPONENTS

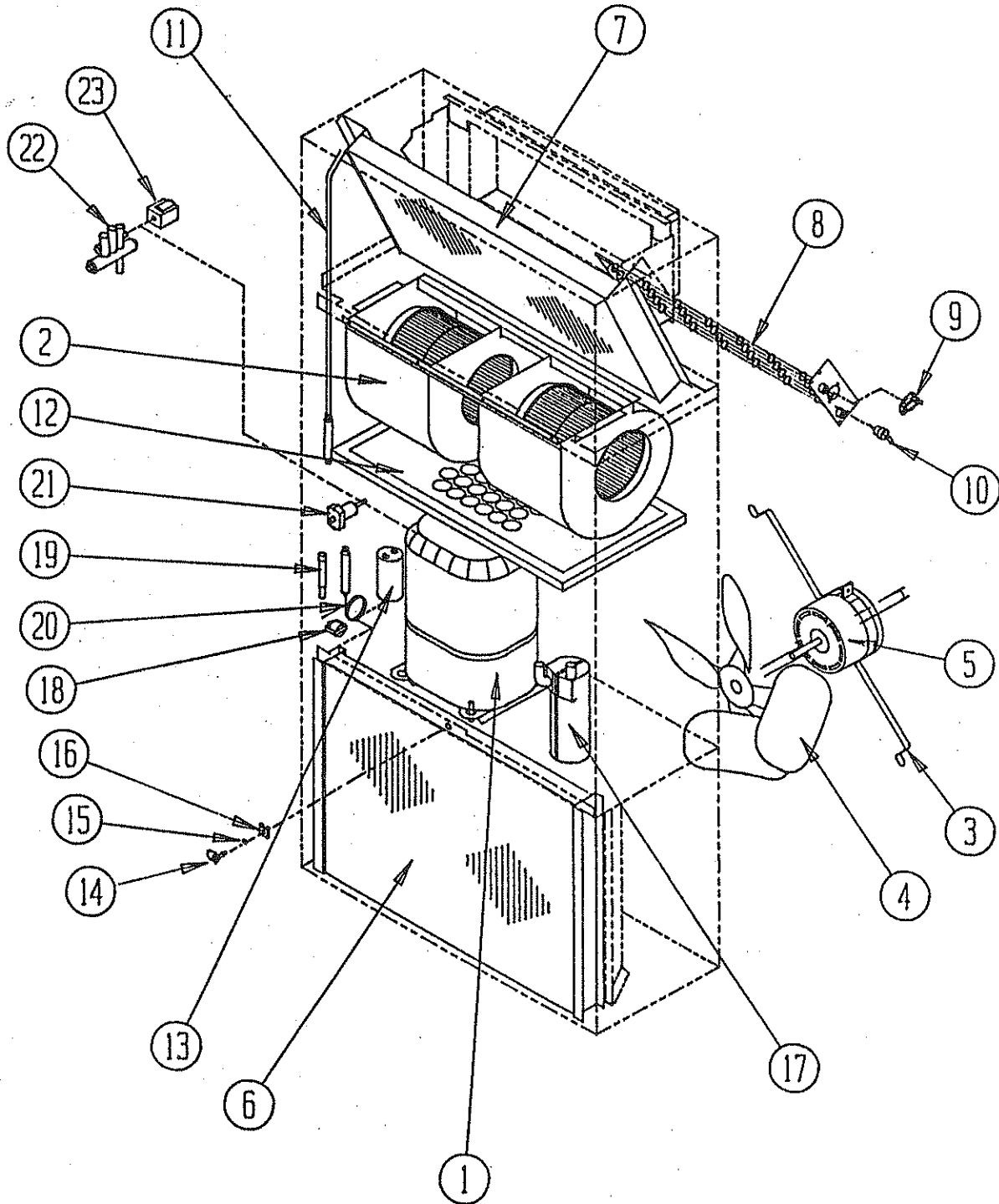

Date: 7-11-89  
Supersedes:

FUNCTIONAL COMPONENTS

Dwg. No.	Part No.	Description	1	1	1	1	1	1	2	2	2	2	2	2	2	2	2
			8	8	8	8	8	8	4	4	4	4	4	4	4	4	4
			W	W	W	W	W	W	W	W	W	W	W	W	W	W	W
			H	H	H	H	H	H	H	H	H	H	H	H	H	H	H
			6	6	6	6	6	6	6	6	6	6	6	6	6	6	6
			A	A	A	A	A	A	A	A	A	A	A	A	A	A	A
			O	O	O	O	O	O	O	O	O	O	O	O	O	O	O
			0	4	8	0	4	8	0	4	8	0	4	8	0	4	8
			N	N	N	C	C	C	N	N	N	C	C	C	C	C	N
1	8000-112	Compressor															X
1	8000-100	Compressor	X	X	X	X	X	X									
1	8000-101	Compressor							X	X	X	X	X	X	X	X	
2	900-038	Blower Assembly (Complete)	X	X	X	X	X	X	X	X	X	X	X	X	X	X	X
3	8200-023	Motor Mount--Fan	X	X	X	X	X	X	X	X	X	X	X	X	X	X	X
4	5151-033	Fan Blade F10H8.7	X	X	X	X	X	X	X	X	X	X	X	X	X	X	X
5	8103-016	Motor--Fan 1/5 hp	X	X	X	X	X	X	X	X	X	X	X	X	X	X	X
6	5051-041	Condenser Coil	X	X	X	X	X	X	X	X	X	X	X	X	X	X	X
7	5060-048	Evaporator Coil	X	X	X	X	X	X	X	X	X	X	X	X	X	X	X
8	8604-088	Heat Strip 4KW		1			1			1				1		1	1
8	8604-090	Heat Strip 8KW			1			1			1					1	1
9	8402-048	Limit Switch 160 Degree		X	X		X	X		X	X			X	X	X	X
10	8402-030	Thermal Cutoff		1	2		1	2		1	2			1	2	2	2
11	800-0087	Cooling Capillary Tube Assembly (36x.059)	X	X	X	X	X	X									
11	800-0089	Cooling Capillary Tube Assembly (28x.059)							X	X	X	X	X	X	X	X	X
12	7004-006	Filter 14x25	X	X	X	X	X	X	X	X	X	X	X	X	X	X	X
13	8552-032	Capacitor 35/370V															X
13	8552-027	Capacitor 25/370V	X	X	X	X	X	X									
13	8552-045	Capacitor 30/370V							X	X	X	X	X	X	X	X	
14	1171-019	1/4 Turn Fastener	X	X	X	X	X	X	X	X	X	X	X	X	X	X	X
15	1171-021	Retainer Clip	X	X	X	X	X	X	X	X	X	X	X	X	X	X	X
16	1171-020	Fastener Receptacle	X	X	X	X	X	X	X	X	X	X	X	X	X	X	X
17	5202-013	Accumulator	X	X	X	X	X	X	X	X	X	X	X	X	X	X	X
18	8408-018	Defrost Thermostat	X	X	X	X	X	X	X	X	X	X	X	X	X	X	X
19	5651-036	Check Valve	X	X	X	X	X	X	X	X	X	X	X	X	X	X	X
20	800-0119	Heating Capillary Tube Assy. (32-1/2x.080)							X	X	X	X	X	X	X	X	X
20	800-0117	Heating Capillary Tube Assy. (25 x .070)	X	X	X	X	X	X									
21	8406-011	High Pressure Switch	X	X	X	X	X	X	X	X	X	X	X	X	X	X	X
22	5650-009	Reversing Valve	X	X	X	X	X	X	X	X	X	X	X	X	X	X	X
23	5650-008	Reversing Valve Solenoid Coil	X	X	X	X	X	X	X	X	X	X	X	X	X	X	X
24	905-0091	Complete Liquid Line Assembly	X	X	X	X	X										
24	905-0092	Complete Liquid Line Assembly						X	X	X	X	X	X	X	X	X	X

Date: 8-23-90  
Supersedes: 7-11-89

CONTROL PANEL

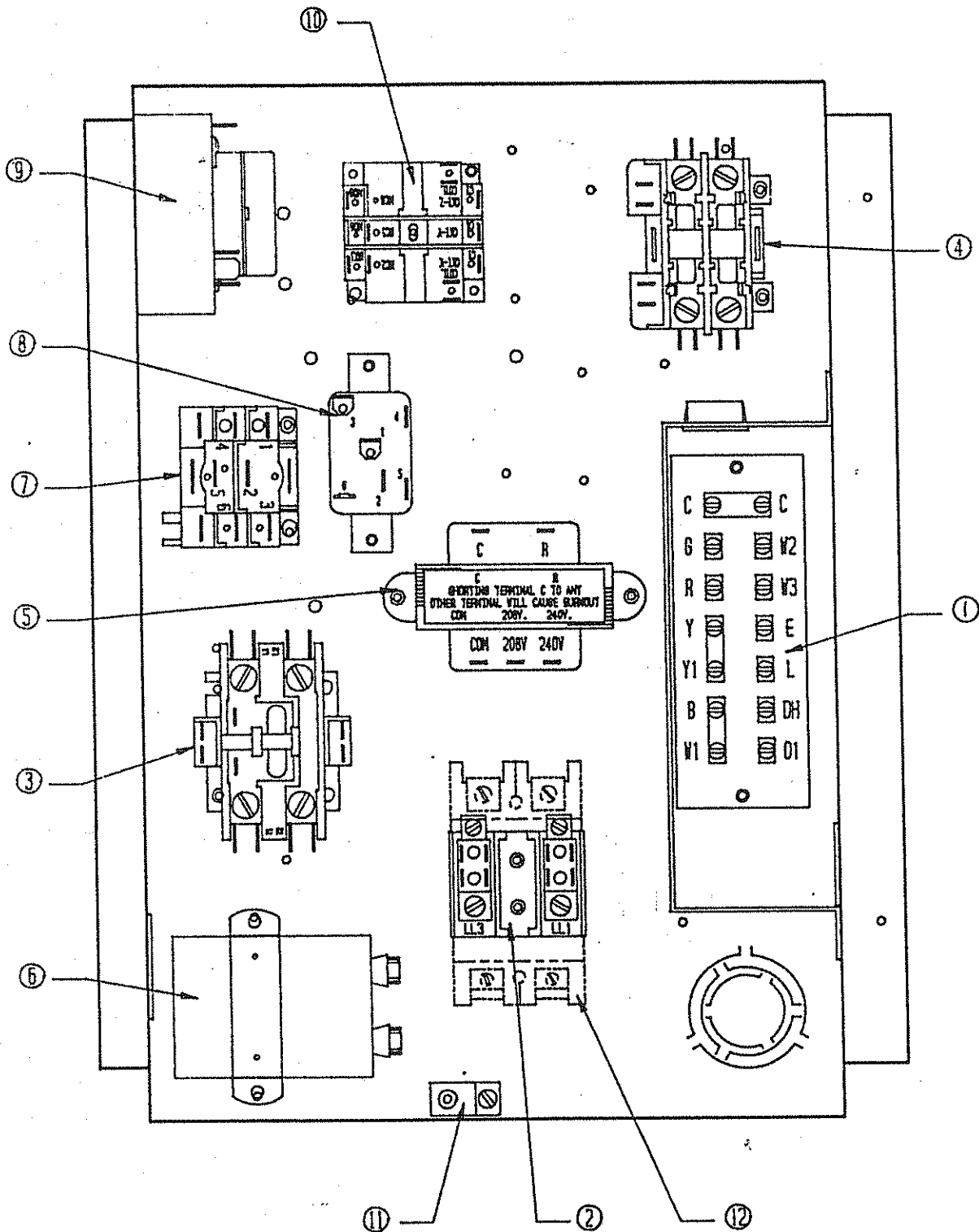

Date: 7-11-89  
Supersedes:

CONTROL PANEL

Dwg. No.	Part No.	Description	1 8 W H 6   A O O N	1 8 W H 6   A O 4 N	1 8 W H 6   A O 8 N	1 8 W H 6   A O 4 C	1 8 W H 6   A O 8 C	2 4 W H 6   A O 0 N	2 4 W H 6   A O 4 N	2 4 W H 6   A O 8 N	2 4 W H 6   A O 4 C	2 4 W H 6   A O 8 C	2 4 W H 6   A O 8 C	2 4 W H 6   A O 8 C
1	8607-019	Low Voltage Terminal Block	X	X	X	X	X	X	X	X	X	X	X	X
2	8607-013	Terminal Block 230V		X	X				X	X				X
3	8401-007	Contacto--Compressor 25A	1	1	1	1	1	1	1	1	1	1	1	1
4	8401-006	Contacto--Heater 2P18		1	1		1	1		1	1		1	1
5	8407-035	Transformer	X	X	X	X	X	X	X	X	X	X	X	X
6	8552-002	Capacitor 5/370V	X	X	X	X	X	X	X	X	X	X	X	X
7	8201-024	Relay--Compressor Fault	X	X	X	X	X	X	X	X	X	X	X	
8	8201-009	Relay--Blower	X	X	X	X	X	X	X	X	X	X	X	X
9	8612-012	Timer	X	X	X	X	X	X	X	X	X	X	X	X
10	8201-047	Relay--Defrost	X	X	X	X	X	X	X	X	X	X	X	X
11	8611-006	Ground Lug	X	X	X	X	X	X	X	X	X	X	X	X
12	8615-009	Circuit Breaker					X							
12	8615-010	Circuit Breaker										X		
12	8615-013	Circuit Breaker									X			
12	8615-016	Circuit Breaker					X						X	
12	8615-022	Circuit Breaker				X								
	4011-110	Wiring Diagram	X					X						
	4011-120	Wiring Diagram		X					X					
	4011-130	Wiring Diagram			X					X				
	4011-111	Wiring Diagram				X					X			
	4011-121	Wiring Diagram					X					X		
	4011-131	Wiring Diagram						X					X	
	4011-430	Wiring Diagram												X
	132-001	Control Panel Cover	X	X	X			X	X	X				X
	132-068	Control Panel Cover				X	X	X			X	X	X	

Date: 7-11-89  
Supersedes:

BLOWER ASSEMBLY

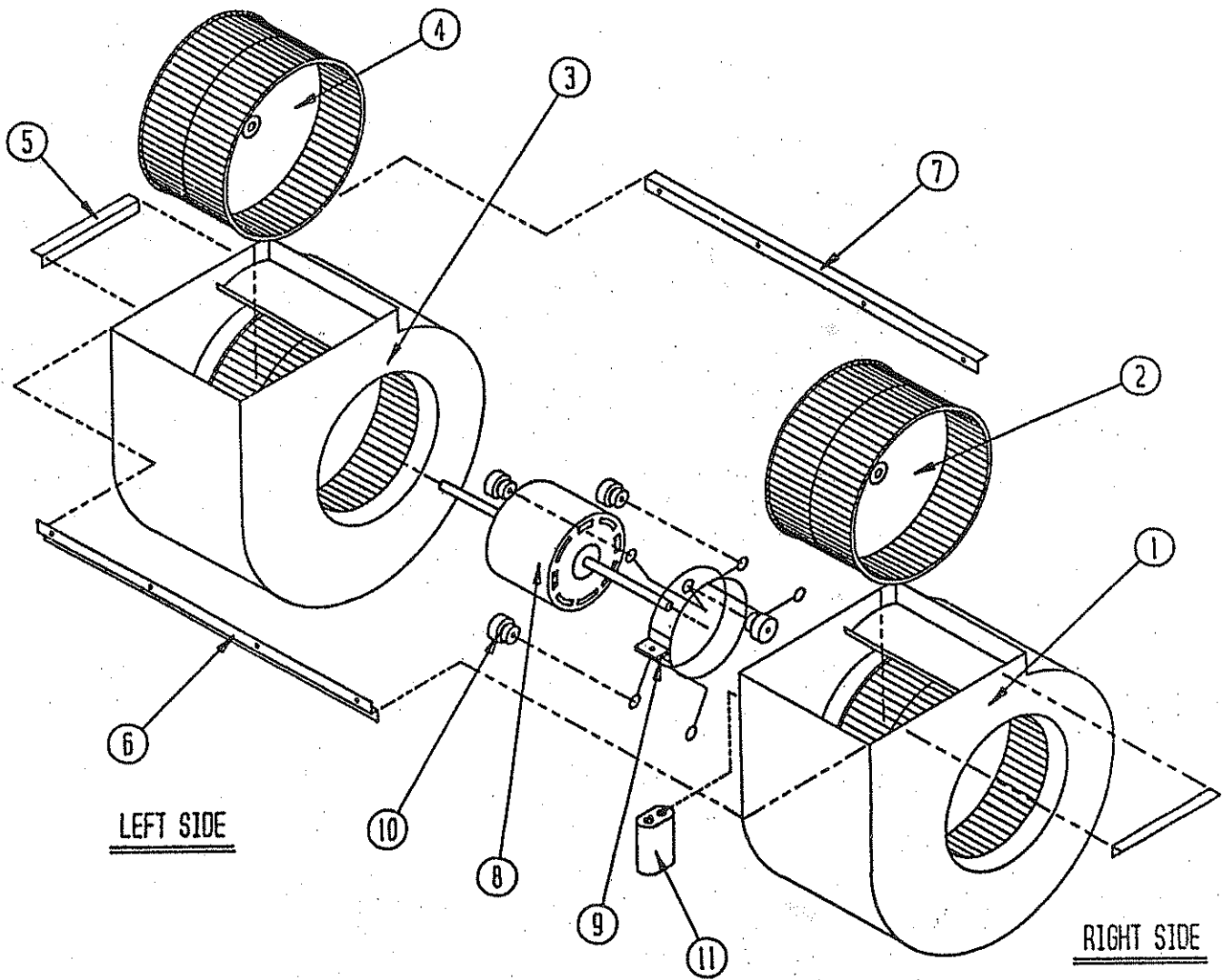

Date: 7-11-89  
Supersedes:



BLOWER ASSEMBLY

Dwg. No.	Part No.	Description	900-038
1	5152-051	Blower Housing And Wheel Assembly	X
2	5152-028	Blower Wheel	X
3	5152-052	Blower Housing And Wheel Assembly	X
4	5152-029	Blower Wheel	X
5	104-001	Angle	X
6	102-300	Offset	X
7	104-505	Angle Back Brace	X
8	8102-009	Blower Motor	X
9	8200-031	Blower Motor Mount	X
10	5451-011	Grommet	X
11	8552-004	Capacitor 7.5/370V	X

Date: 7-11-89  
Supersedes: