

REPLACEMENT PARTS MANUAL

WALL MOUNTED PACKAGE HEAT PUMP MODELS 48WH6 (SUFFIX D016 MODELS)

Manual 2110-513 Revision Date 2-20-91 Supersedes

* GENERAL NOTES *

*Revised and/or additional pages may be issued from time to time.
*A complete and current manual consists of pages dated as shown in the following index.

** INDEX **

<u>Page Description</u>	<u>Page</u>	<u>Date</u>	<u>Supersedes</u>
Cabinet Components--Exploded View	1	2-20-91	
" " --Usage List	2	2-20-91	
Functional Components--Exploded View	3	2-20-91	
" " --Usage List	4	2-20-91	
Control Panel W/Circuit Breaker--Layout	5	2-20-91	
" " " " --Usage List	6	2-20-91	
Blower Assembly--Exploded View	7	2-20-91	
" " --Usage List	8	2-20-91	

*** IMPORTANT ***

Contact the installing and/or local Bard distributor for all parts requirements. Make sure you have the complete model and serial number available from the unit rating plate.

CABINET COMPONENTS

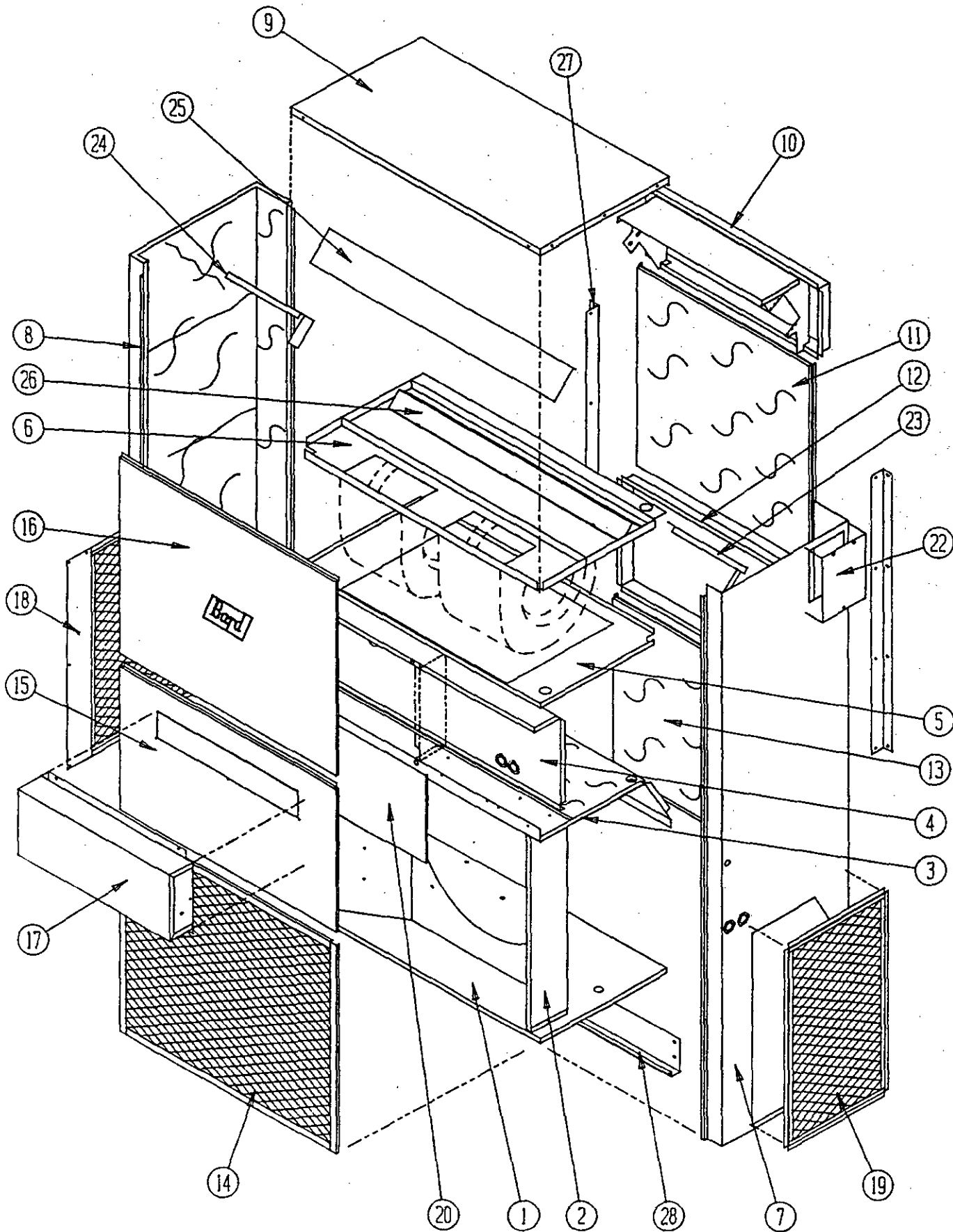

Date: 2-20-91
Supersedes:

CABINET COMPONENTS

Item	Part No.	Description	U S A G E
1	127-005	Lower Base	X
2	124-003	Fan Shroud	X
3	520-133	Condenser Partition	X
4	Control Pnl. Assy.	See Control Panel Assembly Drawing and Parts List	X
5	130-075	Filter Tray	X
6	521-006	Water Pan/Blower Partition	X
7	501-168	Right Side	X
8	501-169	Left Side	X
9	506-097	Top	X
10	111-019	Outlet Airframe Assembly	X
11	508-059	Upper Back	X
12	111-020	Inlet Air Frame Assembly	X
13	108-060	Lower Back	X
14	119-005	Coil Grille	X
15	552-108	Service Door	X
16	514-047	Upper Front	X
17	962002	Fresh Air Damper	X
18	119-006	Left Side Grille	X
19	119-008	Right Side Grille	X
20	Control Cover	See Control Panel Assembly Drawing and Parts List	X
22	542X005	Right Side Cover Plate	X
23	140-010	Support--Right Coil	X
24	140-011	Support--Left Coil	X
25	134-011	Top Evaporator Fill	X
26	136-003	Bottom Evaporator Fill	X
27	112-009	Side Mounting Bracket	X
28	112-006	Bottom Mounting Bracket	X

Date: 2-20-91
Supersedes:

FUNCTIONAL COMPONENTS

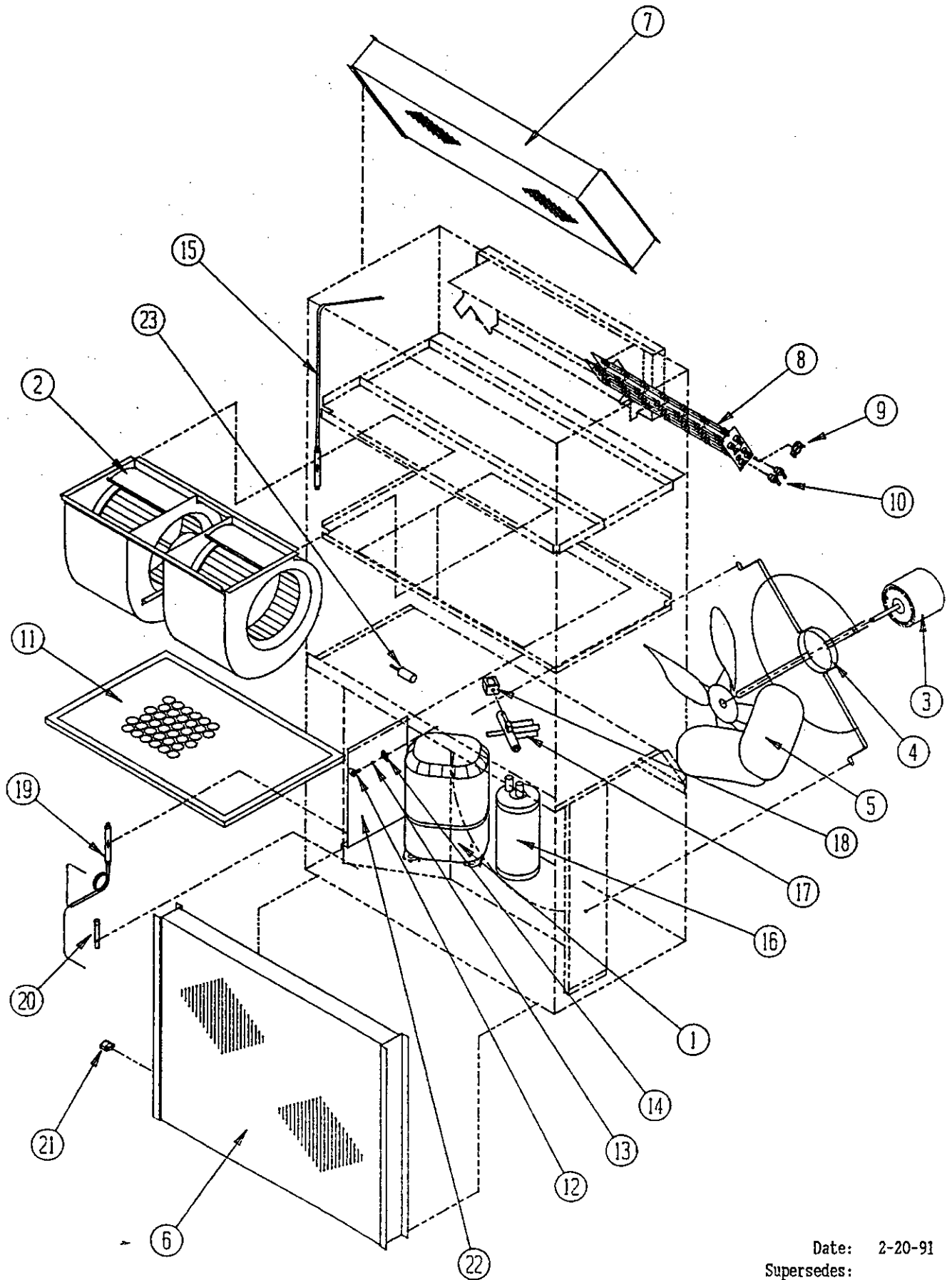

Date: 2-20-91
Supersedes:

FUNCTIONAL COMPONENTS

Dwg. No.	Part No.	Description	48WH6A00C	48WH6A01C	48WH6A15C	48WH6A20C	48WH6B00C	48WH6B09C	48WH6B15C	48WH6B18C	48WH6C00C	48WH6C09C	48WH6C15C
1	8000-082	Compressor AV5546E					x	x	x	x			
1	8000-083	Compressor AV5546E									x	x	x
1	8000-107	Compressor CRL3-0350-PFV	x	x	x	x							
2	900-119	Blower Assembly (Complete)	x	x	x	x	x	x	x	x			
2	900-120	Blower Assembly (Complete)									x	x	x
3	8105-035	Condenser Motor	x	x	x	x	x	x	x				
3	8105-030	Condenser Motor									x	x	x
4	8200-004	Motor Mount--Condenser	x	x	x	x	x	x	x	x	x	x	x
5	5151-027	Fan Blade	x	x	x	x	x	x	x	x	x	x	x
6	5051-029	Condenser Coil	x	x	x	x	x	x	x	x	x	x	x
7	5060-025	Evaporator Coil	x	x	x	x	x	x	x	x	x	x	x
8	8604-047	Heat Strip			x				x				
8	8604-048	Heat Strip						x		2			
8	8604-052	Heat Strip											x
8	8604-072	Heat Strip										x	
8	8604-091	Heat Strip		x		2							
9	8402-047	Limit Control		x	x	x		x	x	x		x	x
10	8402-032	Thermal Cutoff 4K9239H		2	3	4		2	3	4			
10	8402-057	Thermal Cutoff 4K4218AH										2	3
11	7004-016	Air Filter 20 x 30 x 1	x	x	x	x	x	x	x	x	x	x	x
12	1171-019	1/4 Turn Fastener	x	x	x	x	x	x	x	x	x	x	x
13	1171-021	Retainer Washer	x	x	x	x	x	x	x	x	x	x	x
14	1171-020	Receptacle	x	x	x	x	x	x	x	x	x	x	x
15	800-0131	Cooling Capillary Assembly	x	x	x	x	x	x	x	x	x	x	x
16	5202-018	Accumulator	x	x	x	x	x	x	x	x	x	x	x
17	5650-006	Reversing Valve	x	x	x	x	x	x	x	x	x	x	x
18	5650-008	Reversing Valve Solenoid Coil	x	x	x	x	x	x	x	x	x	x	x
19	800-0096	Heating Capillary Assembly	x	x	x	x	x	x	x	x	x	x	x
20	5651-036	Check Valve	x	x	x	x	x	x	x	x	x	x	x
21	8408-016	Defrost Thermostat	x	x	x	x	x	x	x	x	x	x	x
23	8406-049	Low Pressure Switch	x	x	x	x	x	x	x	x	x	x	x

Date: 2-20-91
Supersedes:

CONTROL PANEL WITH CIRCUIT BREAKER

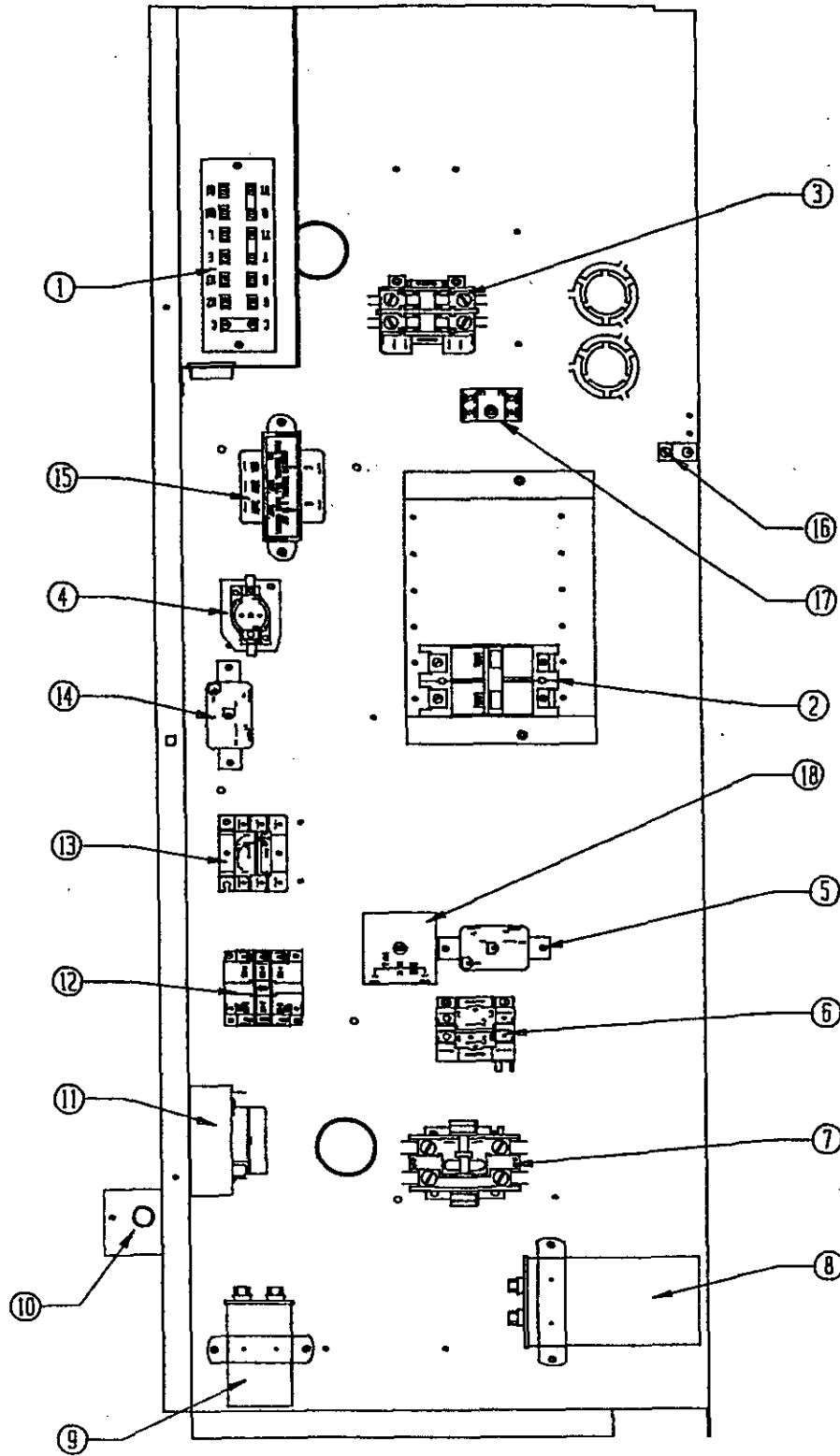

Date: 2-20-91
Supersedes:

CONTROL PANEL
WITH CIRCUIT BREAKER

Dwg. No.	Part No.	Description	4 8 W H 6 A 0 0 C	4 8 W H 6 A 0 0 C	4 8 W H 6 A 0 5 C	4 8 W H 6 A 2 0 0 C	4 8 W H 6 B 0 0 C	4 8 W H 6 B 0 9 C	4 8 W H 6 B 1 5 C	4 8 W H 6 B 1 8 C	4 8 W H 6 C 0 0 C	4 8 W H 6 C 0 9 C	4 8 W H 6 C 1 5 C
1	8607-019	Low Voltage Terminal Strip	X	X	X	X	X	X	X	X	X	X	X
2	8615-016	Circuit Breaker (60A)	X	2	2	3							
2	8615-013	Circuit Breaker (30A)			X								
2	8615-021	Circuit Breaker (45A)					X		X	X			
2	8615-011	Circuit Breaker (60A)						X	X				
2	8615-007	Circuit Breaker (50A)							X				
2	8615-034	Circuit Breaker (40A)											X
2	8615-030	Circuit Breaker (20A)								X			
2	8615-032	Circuit Breaker (30A)									X		
3	8401-006	Heat Contactor		X	2	2		X		2			
3	8401-010	Heat Contactor							X				
3	8401-002	Heat Contactor										X	X
5	8201-008	Heating Blower Relay		X	X	X		X	X	X			
6	8201-032	Defrost Relay									X	X	X
6	8201-024	Compressor Fault Relay	X	X	X	X							
7	8401-003	Compressor Contactor	X	X	X	X							
7	8401-002	Compressor Contactor					X	X	X	X	X	X	X
8	8552-030	Compressor Capacitor 40/440	X	X	X	X							
9	8552-005	Condenser Motor Capacitor 10/370	X	X	X	X	X	X	X	X			
9	8552-026	Condenser Motor Capacitor 15/370									X	X	X
10	8406-010	High Pressure Switch	X	X	X	X	X	X	X	X	X	X	X
11	8612-012	Timer	X	X	X	X	X	X	X	X	X	X	X
12	8201-047	Defrost Relay	X	X	X	X	X	X	X	X	X	X	X
13	8201-013	Emergency Heat Relay			X	X				X			
14	8201-008	Blower Relay	X	X	X	X	X	X	X	X			
14	8201-032	Blower Relay									X	X	X
15	8407-035	Transformer	X	X	X	X	X	X	X	X			
15	8407-040	Transformer									X	X	X
16	8611-006	Ground Terminal	X	2	3	3	X	X	2	2	X	X	X
17	8607-017	Terminal Block									X	X	X
18	8201-050	Time Delay Relay (Compressor)	X	X	X	X	X	X	X	X	X	X	X
	4089-114	Wiring Diagram	X										
	4089-134	Wiring Diagram		X									
	4089-146	Wiring Diagram			X								
	4089-154	Wiring Diagram				X							
	4089-212	Wiring Diagram					X						
	4089-222	Wiring Diagram						X					
	4089-232	Wiring Diagram							X				
	4089-242	Wiring Diagram								X			
	4089-312	Wiring Diagram									X		
	4089-322	Wiring Diagram										X	
	4089-332	Wiring Diagram											X
	132-089	Control Panel Cover									X	X	X
	132-095	Control Panel Cover	X	X	X	X	X	X	X	X			

Date: 2-20-91
Supersedes:

BLOWER ASSEMBLY

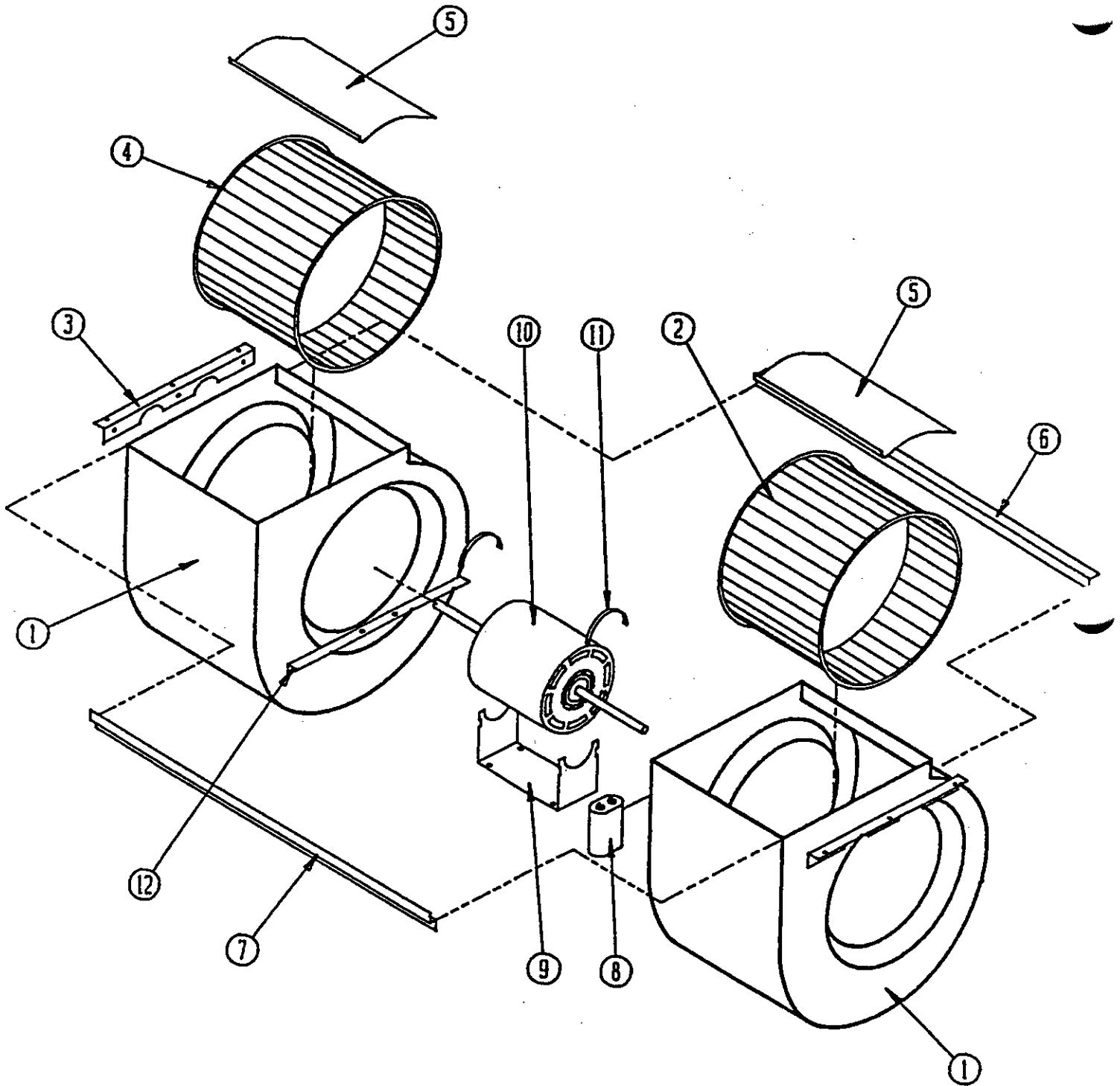

Date: 2-20-91
Supersedes:

2110-513
Page: 7

BLOWER ASSEMBLY

Dwg. No.	Part No.	Description	9 0 0 0 1 1 1 9	9 0 0 0 1 2 0	9 0 0 0 1 2 1
1	151-068	Blower Housing	2	2	2
2	5152-011	Blower Wheel 10-8, CW	x	x	
2	5152-057	Blower Wheel 9-8, CW			x
3	104-791	Blower Angle	2	2	2
4	5152-012	Blower Wheel 10-8, CCW	x	x	
4	5152-058	Blower Wheel 9-8, CCW			x
5	144-126	Diffuser	2	2	2
6	104-802	Back Brace	x	x	x
7	102-389	Front Offset	x	x	x
8	8552-005	Capacitor 10/370	x	x	x
9	128-002	Motor Mount--Cradle	x	x	x
10	8106-023	Motor	x		x
10	8106-025	Motor		x	
11	8200-018	Motor Mount Latch	2	2	2
12	104-788	Motor Support Angle	2	2	2

Date: 2-20-91
Supersedes:

