Replacement Parts Manual

WALL MOUNTED PACKAGE HEAT PUMPS

MODEL: WH381
WH431
WH491

General Notes

- Revised and/or additional pages may be issued from time to time.
- A complete and current manual consists of pages shown in the following contents section.

Important

- Contact the installing and/or local Bard distributor for all parts requirements. Make sure you have the complete model and serial number available from the unit rating plates.

Contents

| <i>Description</i> | <i>Page</i> |
|-----------------------|-------------|
| Cabinet Components | |
| • Exploded View | 1 |
| • Usage List | 2 |
| Functional Components | |
| • Exploded View | 3 |
| • Usage List | 4 |
| Control Panel | |
| • Layout | 5 |
| • Usage List | 6 |
| Blower Assembly | |
| • Exploded View | 7 |
| • Usage List | 7 |



BARD MANUFACTURING COMPANY
Bryan, Ohio 43506

Since 1914...Moving ahead, just as planned.

Manual: 2110-525A
File: Tab 17
Date: 09-09-98

CABINET COMPONENTS

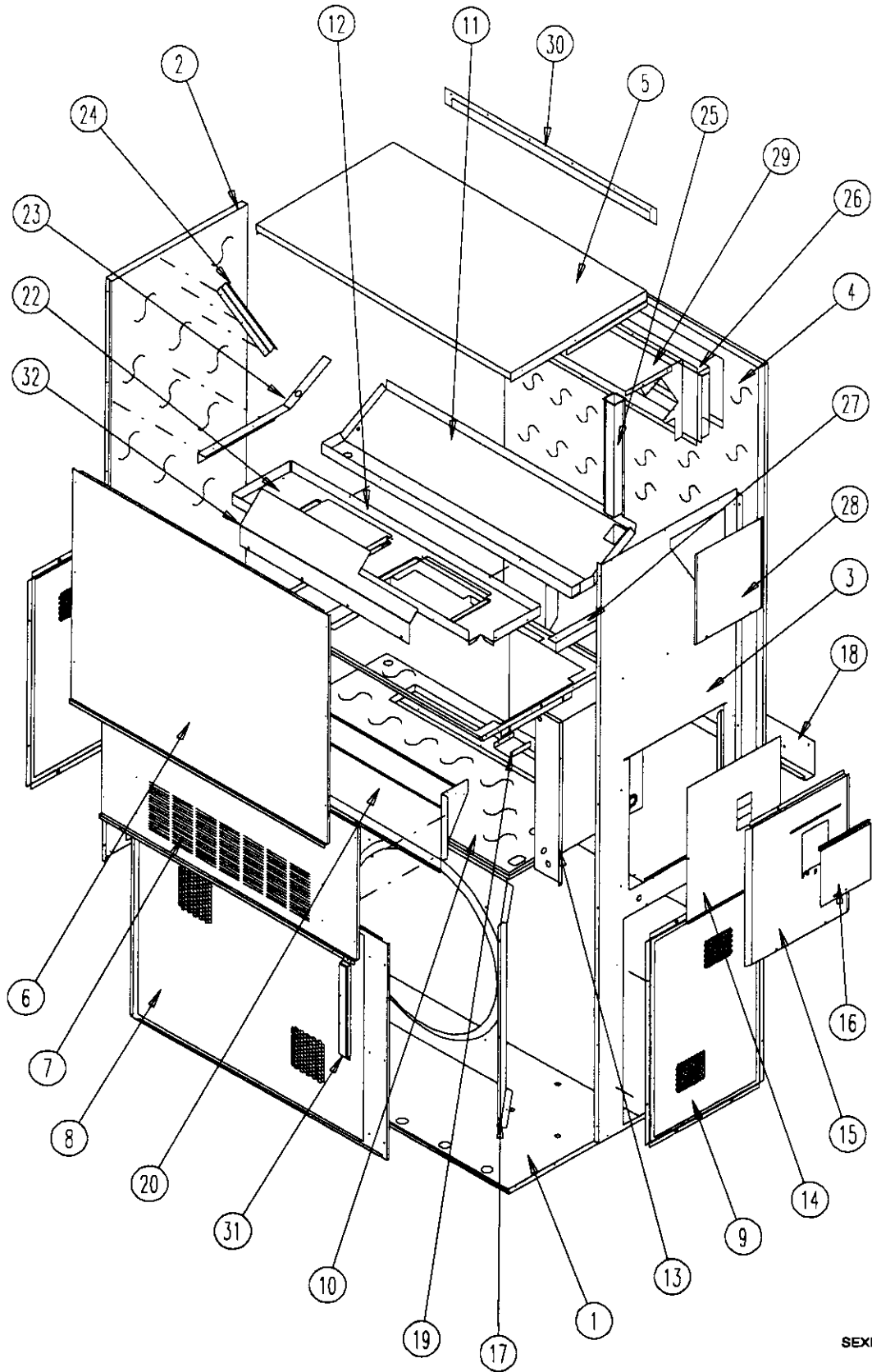

SEXP-305

CABINET COMPONENTS

| Dwg No. | Part No. | Description | WH381-A, B | WH381-C | WH431-A, B | WH431-C | WH491-A, B | WH491-C |
|---------|------------------------|---|------------|---------|------------|---------|------------|---------|
| 1 | S127-299 | Lower Base | X | X | X | X | X | X |
| 2 | S500-562-* ① | Left Side | X | X | X | X | X | X |
| 3 | S500-261-* ① | Right Side | X | X | X | X | X | X |
| 4 | S609-098 | Back | X | X | X | X | X | X |
| 5 | S506-142-* ① | Top | X | X | X | X | X | X |
| 6 | S514-077-* ① | Upper Front | X | X | X | X | X | X |
| 7 | S552-224-* ① | Service Door | X | X | X | X | X | X |
| 8 | 118-044-* ① | Condenser Grille | X | X | X | X | X | X |
| 9 | 118-032-* ① | Side Grille | 2 | 2 | 2 | 2 | 2 | 2 |
| 10 | S521X258 | Condenser Partition | X | X | X | X | X | X |
| 11 | 123-102 | Drain Pan | X | X | X | X | X | X |
| 12 | 121X216 | Blower Partition | X | X | X | X | X | X |
| 13 | Control Panel Assembly | See Control Panel Assembly Drawing and Parts List | X | X | X | X | X | X |
| 14 | S133-114 | Control Panel Cover (Inner) | X | | X | | X | |
| 14 | S133-115 | Control Panel Cover (Inner) | | X | | X | | X |
| 15 | S533-113-* ① | Control Panel Cover (Outer) | X | X | X | X | X | X |
| 16 | S153-322-* ① | Disconnect Access Door | X | X | X | X | X | X |
| 17 | 125-036 | Fan Shroud | X | X | X | X | X | X |
| 18 | 113-140 | Bottom Mounting Bracket | X | X | X | X | X | X |
| 19 | 137-209 | Fill | X | X | X | X | X | X |
| 20 | 960024 | Fresh Air Damper Assembly | X | X | X | X | X | X |
| 22 | 131X099 | Filter Tray | X | X | X | X | X | X |
| 23 | 105X877 | Left Side Support | X | X | X | X | X | X |
| 24 | 147-046-* ① | Left Evaporator Support | X | X | X | X | X | X |
| 25 | 135-128 | Raceway | 2 | 2 | 2 | 2 | 2 | 2 |
| 26 | 111X034 | Outlet Airframe Assembly | X | X | X | X | X | X |
| 27 | 105X878 | Right Side Support | X | X | X | X | X | X |
| 28 | 143-042-* ① | Right Side Cover Plate (Outer) | X | X | X | X | X | X |
| 29 | 135-129 | Heat Shield | X | X | X | X | X | X |
| 30 | 113-150-* ① | Top Rain Flashing | X | X | X | X | X | X |
| 31 | 113-259-* ① | Thermostat Shield | X | X | X | X | X | X |
| 32 | 135-175 | Air Baffle | X | X | X | X | X | X |

① Exterior cabinet parts are manufactured with various paint color options. To insure that you receive the proper paint color, you must include the complete model and serial number of the unit for which cabinet parts are being ordered.

FUNCTIONAL COMPONENTS

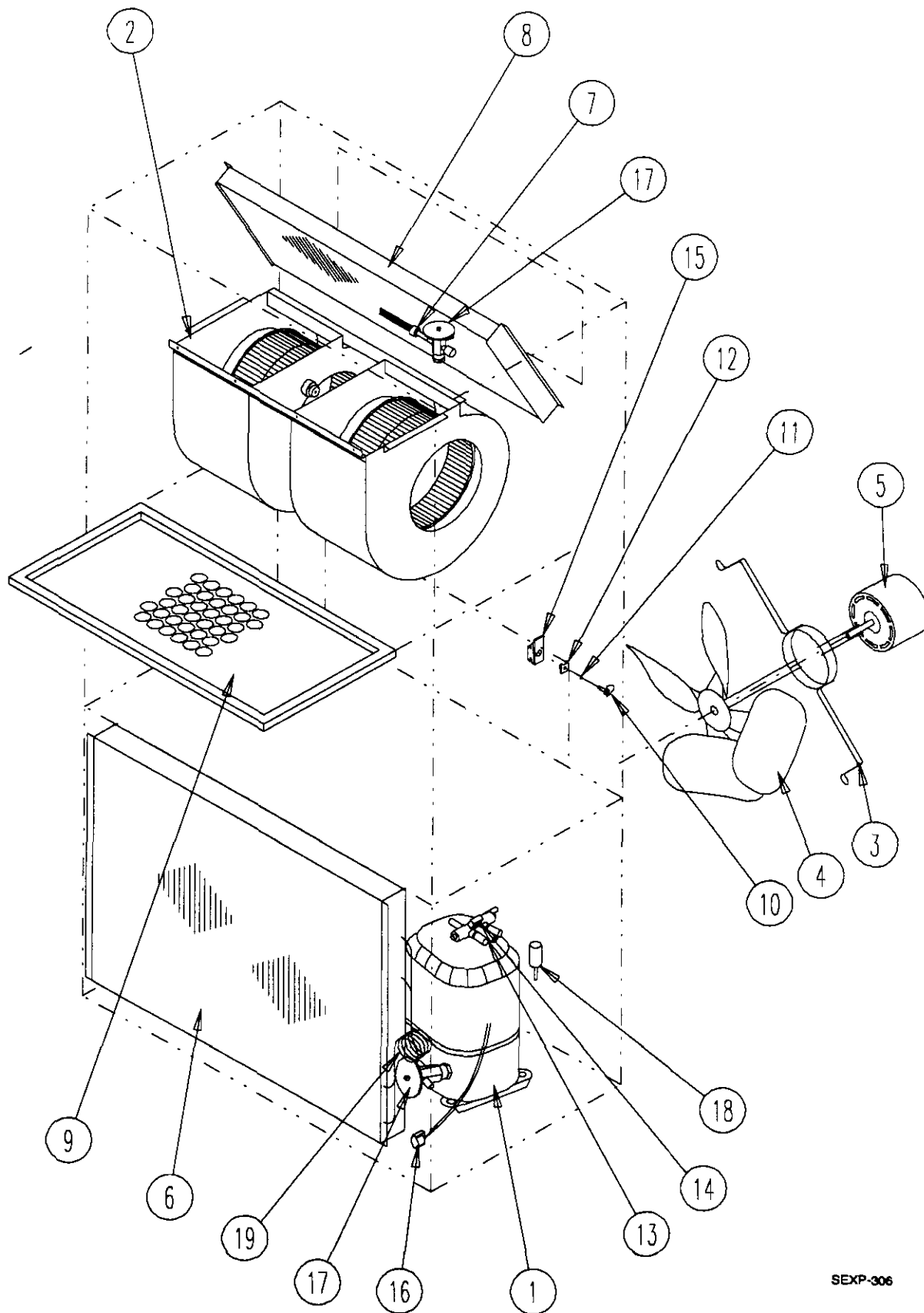

SEXP-306

FUNCTIONAL COMPONENTS

| Dwg No. | Part No. | Description | WH381-A | WH381-B | WH381-C | WH431-A | WH431-B | WH431-C | WH491-A | WH491-B | WH491-C |
|---------|-----------|--------------------------------|---------|---------|---------|---------|---------|---------|---------|---------|---------|
| 1 | 8000-218 | Compressor | | | | | | | X | | |
| 1 | 8000-221 | Compressor | | | | | | | | X | |
| 1 | 8000-222 | Compressor | | | | | | | | | X |
| 1 | 8000-175 | Compressor | X | | | | | | | | |
| 1 | 8000-163 | Compressor | | X | | | | | | | |
| 1 | 8000-164 | Compressor | | | X | | | | | | |
| 1 | 8000-176 | Compressor | | | | X | | | | | |
| 1 | 8000-229 | Compressor | | | | | X | | | | |
| 1 | 8000-230 | Compressor | | | | | | X | | | |
| 2 | S900-242 | Blower Assembly | X | X | | X | X | | X | X | |
| 2 | S900-243 | Blower Assembly | | | X | | | X | | | X |
| 3 | 8200-004 | Fan Motor Mount | X | X | X | X | X | X | X | X | X |
| 4 | 5151-054 | Fan Blade | X | X | X | X | X | X | X | X | X |
| 5 | 8105-039 | Condenser Motor | X | X | | X | X | | X | X | |
| 5 | 8105-046 | Condenser Motor | | | X | | | X | | | X |
| 6 | 5051-107 | Condenser Coil | X | X | X | X | X | X | | | |
| 6 | 5051-077 | Condenser Coil | | | | | | | X | X | X |
| 7 | 800-0287 | Cooling Distributor Assembly | X | X | X | | | | | | |
| 7 | 800-0288 | Cooling Distributor Assembly | | | | X | X | X | X | X | X |
| 8 | 5060-070 | Evaporator Coil | X | X | X | | | | | | |
| 8 | 5060-082 | Evaporator Coil | | | | X | X | X | X | X | X |
| 9 | 7004-016 | Air Filter 1" Throw-away | X | X | X | X | X | X | X | X | X |
| 9 | 7003-030 | Air Filter 1" Washable | X | X | X | X | X | X | X | X | X |
| 9 | 7004-027 | Air Filter 2" Pleated | X | X | X | X | X | X | X | X | X |
| 10 | 1171-022 | 1/4" Turn Fastener | X | X | X | X | X | X | X | X | X |
| 11 | 1171-024 | 1/4" Turn Retainer | X | X | X | X | X | X | X | X | X |
| 12 | 1171-023 | 1/4" Receptacle | X | X | X | X | X | X | X | X | X |
| 13 | 5650-021 | Reversing Valve | X | X | X | X | X | X | | | |
| 13 | 5650-025 | Reversing Valve | | | | | | | X | X | X |
| 14 | 5650-022 | Reversing Valve Solenoid | X | X | X | X | X | X | X | X | X |
| 15 | 1171-044 | Latch - Locking | X | X | X | X | X | X | X | X | X |
| 16 | 8408-027 | Defrost Sensor | X | X | X | X | X | X | X | X | X |
| 17 | 5651-102 | Expansion Valve | 2 | 2 | 2 | 2 | 2 | 2 | | | |
| 17 | 5651-103 | Expansion Valve | | | | | | | 2 | 2 | 2 |
| 18 | 1804-0106 | High Pressure Switch (Flare) ① | X | X | X | X | X | X | X | X | X |
| 19 | 800-0210 | Heating Distributor Assembly | X | X | X | X | X | X | | | |
| 19 | 800-0211 | Heating Distributor Assembly | | | | | | | X | X | X |
| NS | 1804-0107 | Low Pressure Switch (Flare) ① | X | X | X | X | X | X | X | X | X |
| NS | 1804-0108 | Low Ambient Switch (Flare) ① | X | X | X | X | X | X | X | X | X |

NS - Not Shown

① - Optional

CONTROL PANEL

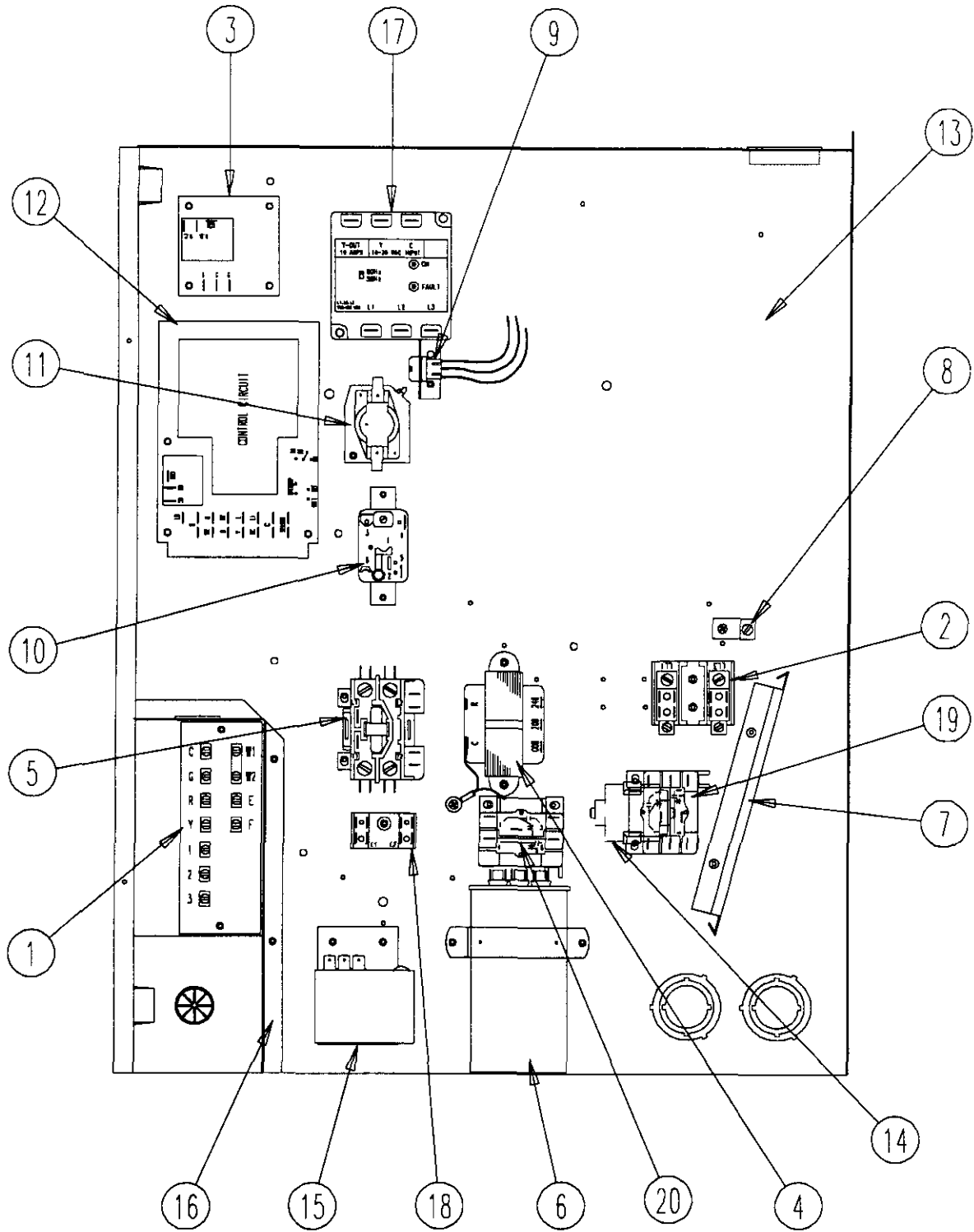

SEXP-311

CONTROL PANEL

| Dwg No. | Part No. | Description | WH381-A | WH381-B | WH381-C | WH431-A | WH431-B | WH431-C | WH491-A | WH491-B | WH491-C |
|---------|----------|-----------------------------|---------|---------|---------|---------|---------|---------|---------|---------|---------|
| 1 | 8607-019 | Low Voltage Terminal Strip | X | X | X | X | X | X | X | X | X |
| 2 | 8607-013 | Terminal Block 2 Pole | X | | | X | | | X | | |
| 2 | 8607-014 | Terminal Block 3 Pole | | X | X | | X | X | | X | X |
| 2 | 8607-015 | Phelon Insulator | | | X | | | X | | | X |
| 3 | 8201-056 | Blower Control | X | X | | X | X | | X | X | |
| 3 | 8201-032 | Blower Relay | | | X | | | X | | | X |
| 4 | 8407-035 | Transformer | X | X | | X | X | | X | X | |
| 4 | 8407-042 | Transformer | | | X | | | X | | | X |
| 5 | 8401-027 | Compressor Contactor | | | | | | | | X | |
| 5 | 8401-002 | Compressor Contactor | | X | X | | X | X | | | X |
| 5 | 8401-016 | Compressor Contactor | X | | | X | | | X | | |
| 6 | 8552-005 | Outdoor Motor Capacitor | | X | X | | X | X | | X | X |
| 6 | 8552-072 | Compressor Capacitor | X | | | | | | | | |
| 6 | 8552-045 | Compressor Capacitor | | | | | | | X | | |
| 6 | 8552-059 | Compressor Capacitor | | | | X | | | | | |
| 7 | 135-130 | Wire Shield | X | X | X | X | X | X | X | X | X |
| 8 | 8611-006 | Ground Terminal | X | X | X | X | X | X | X | X | X |
| 9 | 3000-977 | 6 Pin Connector | X | X | X | X | X | X | X | X | X |
| 10 | 8201-009 | Low Ambient Bypass Relay ① | X | X | X | X | X | X | X | X | X |
| 11 | 8201-065 | Low Pressure Bypass (TDR) ① | X | X | X | X | X | X | X | X | X |
| 12 | 8201-069 | Heat Pump Control Board | X | X | X | X | X | X | X | X | X |
| 13 | 117X143 | Control Panel | X | X | X | X | X | X | X | X | X |
| 14 | 8551-005 | Start Device | X | | | | | | | | |
| 15 | 8408-034 | Outdoor Fan Thermostat | X | X | X | X | X | X | X | X | X |
| 16 | 117X139 | Low Voltage Box | X | X | X | X | X | X | X | X | X |
| 17 | 8201-085 | Phase Monitor | | X | X | | X | X | | X | X |
| 18 | 8607-017 | Terminal Block ① | X | X | X | X | X | X | X | X | X |
| 19 | 8201-086 | Motor Speed Relay | | | X | | | X | | | X |
| 20 | 8201-032 | Outdoor Fan Relay | | | X | | | X | | | X |
| NS | 4096-116 | Wiring Diagram | X | | | X | | | X | | |
| NS | 4096-216 | Wiring Diagram | | X | | | X | | | | |
| NS | 4096-316 | Wiring Diagram | | | | | | X | | | |
| NS | 4096-217 | Wiring Diagram | | | | | | | | X | |
| NS | 4096-317 | Wiring Diagram | | | | | | | | | X |
| NS | 4096-318 | Wiring Diagram | | | X | | | | | | |

NS - Not Shown

① - Optional

BLOWER ASSEMBLY

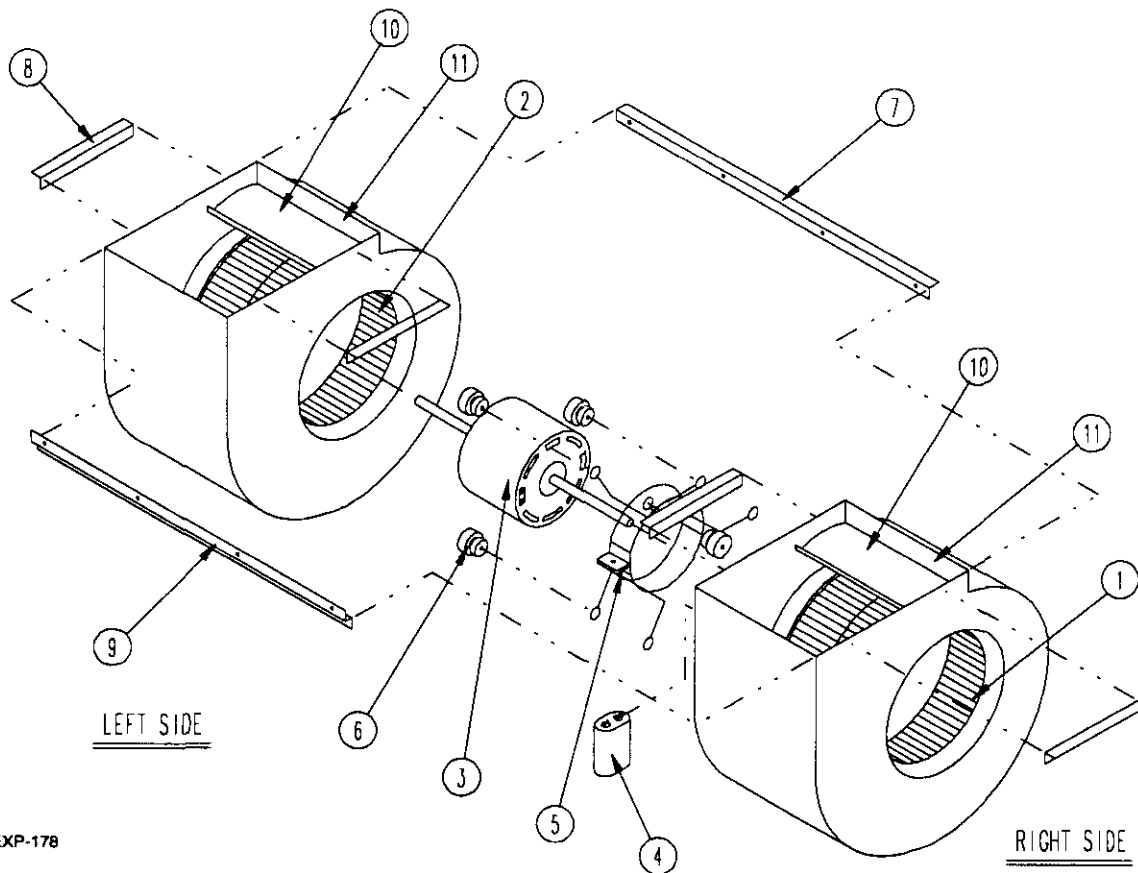

SEXP-178

| Dwg. No. | Part No. | Description | 900-242 | 900-243 |
|----------|----------|------------------------|---------|---------|
| 1 | 5152-011 | 10 Inch Wheel (CW) | X | X |
| 2 | 5152-012 | 10 Inch Wheel (CCW) | X | X |
| 3 | 8104-012 | Blower Motor (230/208) | X | |
| 3 | 8104-014 | Blower Motor (460) | | X |
| 4 | 8552-005 | Capacitor | X | X |
| 5 | 8200-040 | Motor Mount | X | X |
| 6 | 5451-001 | Grommets | 6 | 6 |
| 7 | 105-880 | Back Brace | X | X |
| 8 | 105-881 | Side Angle | 4 | 4 |
| 9 | 103-389 | Front Brace | X | X |
| 10 | 151-101 | Housing | 2 | 2 |
| 11 | 144-166 | Diffuser | 2 | 2 |