REPLACEMENT PARTS MANUAL

QTEC SERIES PACKAGED HEAT PUMP

Models:

QH242	QH302
QH362	QH422
QH482	QH602

General Notes

- Revised and/or additional pages may be issued from time to time.
- A complete and current manual consists of pages shown in the following contents section.

Contents

Description	Page
Cabinet Components	
♦ Exploded View	1
♦ Usage List	2
♦ Usage List	3
♦ Usage List	4
♦ Usage List	5
♦ Blank Page	6
Functional Components	
♦ Exploded View	7
♦ Usage List	8
♦ Usage List	9
♦ Usage List	10
♦ Blank Page	11
Upper Control Panel Components	
♦ Exploded View	12
♦ Usage List	13
♦ Usage List	14
♦ Usage List	15
♦ Usage List	16
♦ Usage List	17
♦ Usage List	18
Lower Control Panel Components	
♦ Exploded View	19
♦ Usage List	20
Blower Assembly Components	
♦ Exploded View	21
♦ Usage List	22
Optional Climate Control Components	
♦ Exploded View	23
♦ Usage List	24
Wall Sleeve Cabinet Components	
♦ Exploded View	25
♦ Usage List	26



BARD MANUFACTURING COMPANY
Bryan, Ohio 43506
Since 1914...Moving ahead, just as planned.

Manual: 2110-533A
Supersedes: 2110-533
File: Tab 14
Date: 03-22-01

CABINET COMPONENTS

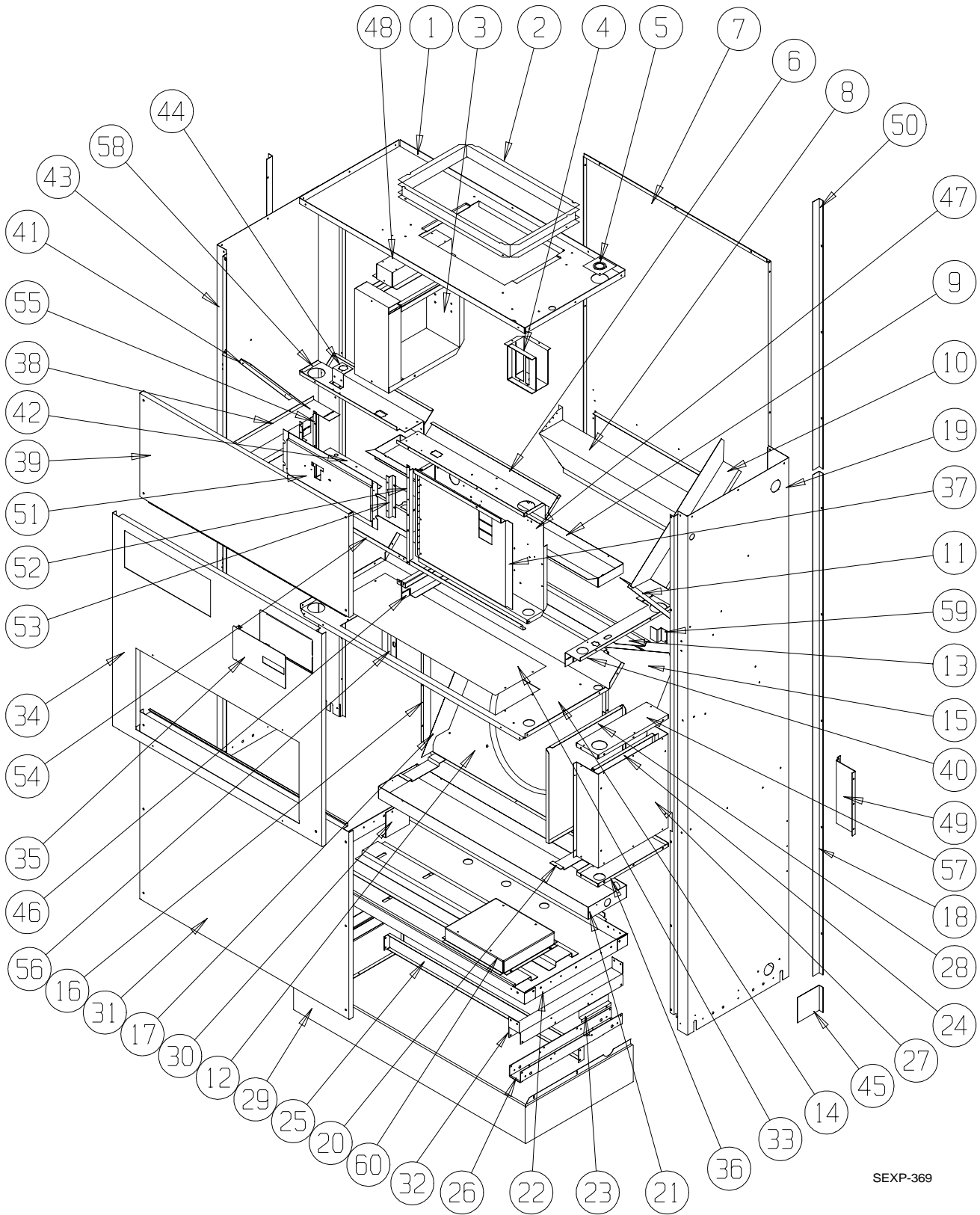

SEXP-369

This Exploded View is referenced in Tables on Page 2, 3,4 & 5

CABINET COMPONENTS

Drawing No.	Part No.	Description	QH242-A, B QH242LA, LB		QH242-C QH242LC		QH302-A, B QH302LA, LB		QH302-C QH302LC		QH362-A, -B QH362LA, LB		QH362-C QH362LC		QH422-A, B QH422LA, LB		QH422-C QH422LC	
1	506-225	Top Assembly	X	X	X	X	X	X	X	X	X	X	X	X	X	X	X	X
2	110-044	Outlet Duct Flange	2	2	2	2	2	2	2	2	2	2	2	2	2	2	2	2
3	See Page 12	Heater Package Assembly (Optional)	X	X	X	X	X	X	X	X	X	X	X	X	X	X	X	X
4	117-187	Low Voltage Box Assembly (Optional)	X	X	X	X	X	X	X	X	X	X	X	X	X	X	X	X
5	136-359	T. K. O. Plate	X	X	X	X	X	X	X	X	X	X	X	X	X	X	X	X
6	534-191	Evaporator Coil Shield – Right	X	X	X	X	X	X	X	X	X	X	X	X	X	X	X	X
7	508-133	Back Assembly	X	X	X	X	X	X	X	X	X	X	X	X	X	X	X	X
8	538-106	Fresh Air Damper Assembly	X	X	X	X	X	X	X	X	X	X	X	X	X	X	X	X
9	523-104	Evaporator Drain Pan Assembly	X	X	X	X	X	X	X	X	X	X	X	X	X	X	X	X
10	134-154	Wire Channel	X	X	X	X	X	X	X	X	X	X	X	X	X	X	X	X
11	140X277	Right Evaporator Support	X	X	X	X	X	X	X	X	X	X	X	X	X	X	X	X
12	124-032	Fan Shroud Back	X	X	X	X	X	X	X	X	X	X	X	X	X	X	X	X
13	142-055	Condenser Coil Fill	X	X	X	X	X	X	X	X	X	X	X	X	X	X	X	X
14	520-346	Condenser Partition Assembly	X	X	X	X	X	X	X	X	X	X	X	X	X	X	X	X
15	124X043	Fan Shroud Right Side	X	X	X	X	X	X	X	X	X	X	X	X	X	X	X	X
16	124Y043	Fan Shroud Left Side	X	X	X	X	X	X	X	X	X	X	X	X	X	X	X	X
17	140-229	Condenser Coil Support	2	2	2	2	2	2	2	2	2	2	2	2	2	2	2	2
18	135-177-* ①	Side Trim – Lower	2	2	2	2	2	2	2	2	2	2	2	2	2	2	2	2
19	500-392-* ①	Right Side Assembly	X	X	X	X	X	X	X	X	X	X	X	X	X	X	X	X
20	140-227	Subcooling Loop Hold Down	3	3	3	3	3	3	3	3	3	3	3	3	3	3	3	3
21	123-094	Condenser Drain Pan Assembly	X	X	X	X	X	X	X	X	X	X	X	X	X	X	X	X
22	527-309-X	Lower Base Assembly	X	X	X	X	X	X	X	X	X	X	X	X	X	X	X	X
23	102-415	Pile Seal Offset	2	2	2	2	2	2	2	2	2	2	2	2	2	2	2	2
24	117-240	Lower Control Panel Plate	X	X	X	X	X	X	X	X	X	X	X	X	X	X	X	X
25	135-189	Base Shield	X	X	X	X	X	X	X	X	X	X	X	X	X	X	X	X
26	140-276	Lower Roller Support	2	2	2	2	2	2	2	2	2	2	2	2	2	2	2	2
27	See Page 7	Control Panel Components	X	X	X	X	X	X	X	X	X	X	X	X	X	X	X	X
28	133-164	Control Panel Door – Lower	X	X	X	X	X	X	X	X	X	X	X	X	X	X	X	X
29	534-155-6	Base Trim Assembly	X	X	X	X	X	X	X	X	X	X	X	X	X	X	X	X
30	140-230	Drain Pan Support	X	X	X	X	X	X	X	X	X	X	X	X	X	X	X	X
31	552-332-* ①	Condenser Door Assembly	X	X	X	X	X	X	X	X	X	X	X	X	X	X	X	X
32	140-280	Upper Roller Support	2	2	2	2	2	2	2	2	2	2	2	2	2	2	2	2
33	536-351	Condenser Blank Off Plate	X	X	X	X	X	X	X	X	X	X	X	X	X	X	X	X
34	552-330-* ①	Filter Door Assembly	X	X	X	X	X	X	X	X	X	X	X	X	X	X	X	X
35	152-336-* ①	Circuit Breaker Door	X	X	X	X	X	X	X	X	X	X	X	X	X	X	X	X
36	116-238	Lower Control Panel Bottom	X	X	X	X	X	X	X	X	X	X	X	X	X	X	X	X
37	132-166	Pull Disconnect Door Inner		X		X		X		X		X		X		X		X
37	132-165	Circuit Breaker Door Inner	X		X		X		X		X		X		X		X	
38	113-281	Left Filter Bracket	X	X	X	X	X	X	X	X	X	X	X	X	X	X	X	X
39	552-331-* ①	Blower Door Assembly	X	X	X	X	X	X	X	X	X	X	X	X	X	X	X	X

Continued on Page 3

① Exterior cabinet parts are manufactured with various color options. To insure that you receive the proper color, you must include the complete models and serial number of the unit for which parts are being ordered.

This Table references Exploded View on Page 1

CABINET COMPONENTS

Drawing No.	Part No.	Description	QH242-A, B QH242LA, LB		QH242-C QH242LC		QH302-A, B QH302LA, LB		QH302-C QH302LC		QH362-A, -B QH362LA, LB		QH362-C QH362LC		QH422-A, B QH422LA, LB		QH422-C QH422LC	
<i>Continued from Page 2</i>																		
40	113-282	Right Filter Bracket	X	X	X	X	X	X	X	X	X	X	X	X	X	X	X	X
41	140Y277	Left Evaporator Support	X	X	X	X	X	X	X	X	X	X	X	X	X	X	X	X
42	117-243	Relay Control Panel	X	X	X	X	X	X	X	X	X	X	X	X	X	X	X	X
43	500-391-* ①	Left Side Assembly	X	X	X	X	X	X	X	X	X	X	X	X	X	X	X	X
44	113-142	Expansion Valve Mounting Plate	X	X	X	X	X	X	X	X	X	X	X	X	X	X	X	X
45	135-165-* ①	Base Trim Extension	2	2	2	2	2	2	2	2	2	2	2	2	2	2	2	2
46	112X283	Center Right Filter Bracket	X	X	X	X	X	X	X	X	X	X	X	X	X	X	X	X
46	112Y283	Center Left Filter Bracket	X	X	X	X	X	X	X	X	X	X	X	X	X	X	X	X
47	See Page 17	Pull Disconnect Assembly				X			X			X						X
47	See Page 15	Circuit Breaker Box Assembly	X			X			X			X						X
48	112-229	Heatstrip Bracket	X	X	X	X	X	X	X	X	X	X	X	X	X	X	X	X
49	112-234	Mounting Bracket	2	2	2	2	2	2	2	2	2	2	2	2	2	2	2	2
50	135-178-* ①	Side Trim – Upper	2	2	2	2	2	2	2	2	2	2	2	2	2	2	2	2
51	See page 13	Thermostat Mounting Plate	X	X	X	X	X	X	X	X	X	X	X	X	X	X	X	X
52	104-1096	Left Thermostat Support Angle	X	X	X	X	X	X	X	X	X	X	X	X	X	X	X	X
53	103-442	Thermostat Support Offset	2	2	2	2	2	2	2	2	2	2	2	2	2	2	2	2
54	104-1097	Front Filter Angle	X	X	X	X	X	X	X	X	X	X	X	X	X	X	X	X
55	104-1096	Right Thermostat Support Angle	X	X	X	X	X	X	X	X	X	X	X	X	X	X	X	X
56	102-434	Sleeve Offset	X	X	X	X	X	X	X	X	X	X	X	X	X	X	X	X
57	117-237	Lower Control Panel Top	X	X	X	X	X	X	X	X	X	X	X	X	X	X	X	X
58	534-190	Evaporator Coil Shield – Left	X	X	X	X	X	X	X	X	X	X	X	X	X	X	X	X
59	103-443	Door Latch Offset	X	X	X	X	X	X	X	X	X	X	X	X	X	X	X	X
60	140-282	Transformer Support			X				X			X						X

- ① Exterior cabinet parts are manufactured with various color options. To insure that you receive the proper color, you must include the complete models and serial number of the unit for which parts are being ordered.

This Table references Exploded View on Page 1

CABINET COMPONENTS

Drawing No.	Part No.	Description		
			QH482-A, -B QH482LA, LB QH602-A, -B	QH482-C QH482LC QH602-C
1	506-226	Top Assembly	X	X
2	110-044	Outlet Duct Flange	2	2
3	See Page 12	Heater Package Assembly (Optional)	X	X
4	117-187	Low Voltage Box Assembly (Optional)	X	X
5	136-359	T. K. O. Plate	X	X
6	534-195	Evaporator Coil Shield – Right	X	X
7	508-149	Back Assembly	X	X
8	538-106	Fresh Air Damper Assembly	X	X
9	523-105	Evaporator Drain Pan Assembly	X	X
10	134-154	Wire Channel	X	X
11	140X277	Right Evaporator Support	X	X
12	124-046	Fan Shroud Back	X	X
13	143-066	Condenser Coil Fill	X	X
14	520-347	Condenser Partition Assembly	X	X
15	124-041	Fan Shroud Right Side	X	X
16	124-045	Fan Shroud Left Side	X	X
17	140-229	Condenser Coil Support	2	2
18	135-177-* ①	Side Trim – Lower	2	2
19	500-392-* ①	Right Side Assembly	X	X
20	140-227	Subcooling Loop Hold Down	3	3
21	123-099	Condenser Drain Pan Assembly	X	X
22	527-294	Lower Base Assembly	X	X
23	102-415	Pile Seal Offset	2	2
24	117-240	Lower Control Panel Plate	X	X
25	134-194	Base Shield	X	X
26	140-276	Lower Roller Support	2	2
27	See Page 7	Control Panel Components	X	X
28	133-164	Control Panel Door – Lower	X	X
29	534-174-6	Base Trim Assembly		
30	140-230	Drain Pan Support	X	X
31	552-334-* ①	Condenser Door Assembly	X	X
32	140-280	Upper Roller Support	2	2
33	536-351	Condenser Blank Off Plate		
34	552-335-* ①	Filter Door Assembly	X	X
35	152-336-* ①	Circuit Breaker Door	X	X
36	116-238	Lower Control Panel Bottom	X	X
37	132-166	Pull Disconnect Door Inner		X
37	132-165	Circuit Breaker Door Inner	X	
38	112-281	Left Filter Bracket	X	X
39	552-333-* ①	Blower Door Assembly	X	X

Continued on Page 5

- ① Exterior cabinet parts are manufactured with various color options. To insure that you receive the proper color, you must include the complete models and serial number of the unit for which parts are being ordered.

This Table references Exploded View on Page 1

CABINET COMPONENTS

Drawing No.	Part No.	Description	QH482-A, -B QH482LA, LB QH602-A, -B		QH482-C QH482LC QH602-C	
<i>Continued from Page 4</i>						
40	112-286	Right Filter Bracket		X		X
41	140Y277	Left Evaporator Support		X		X
42	116-243	Relay Control Panel		X		X
43	500-393-* ①	Left Side Assembly		X		X
44	113-142	Expansion Valve Mounting Plate		X		X
45	134-165-* ①	Base Trim Extension		2		2
46	112X283	Center Right Filter Bracket		X		X
46	112Y283	Center Left Filter Bracket		X		X
47	See Page 17	Pull Disconnect Assembly				X
47	See Page 15	Circuit Breaker Box Assembly		X		
48	112-229	Heatstrip Bracket		X		X
49	112-234	Mounting Bracket		2		2
50	135-178-* ①	Side Trim – Upper		2		2
51	See page 13	Thermostat Mounting Plate		X		X
52	104-1096	Left Thermostat Support Angle		X		X
53	103-442	Thermostat Support Offset		X		X
54	104-1097	Front Filter Angle		X		X
55	104-1096	Right Thermostat Support Angle		X		X
56	102-434	Sleeve Offset		X		X
57	117-237	Lower Control Panel Top		X		X
58	534-190	Evaporator Coil Shield – Left		X		X
59	103-443	Door Latch Offset		X		X
60	140-282	Transformer Support				X

- ① Exterior cabinet parts are manufactured with various color options. To insure that you receive the proper color, you must include the complete models and serial number of the unit for which parts are being ordered.

This Table references Exploded View on Page 1

This page has been left blank intentionally.

FUNCTIONAL COMPONENTS

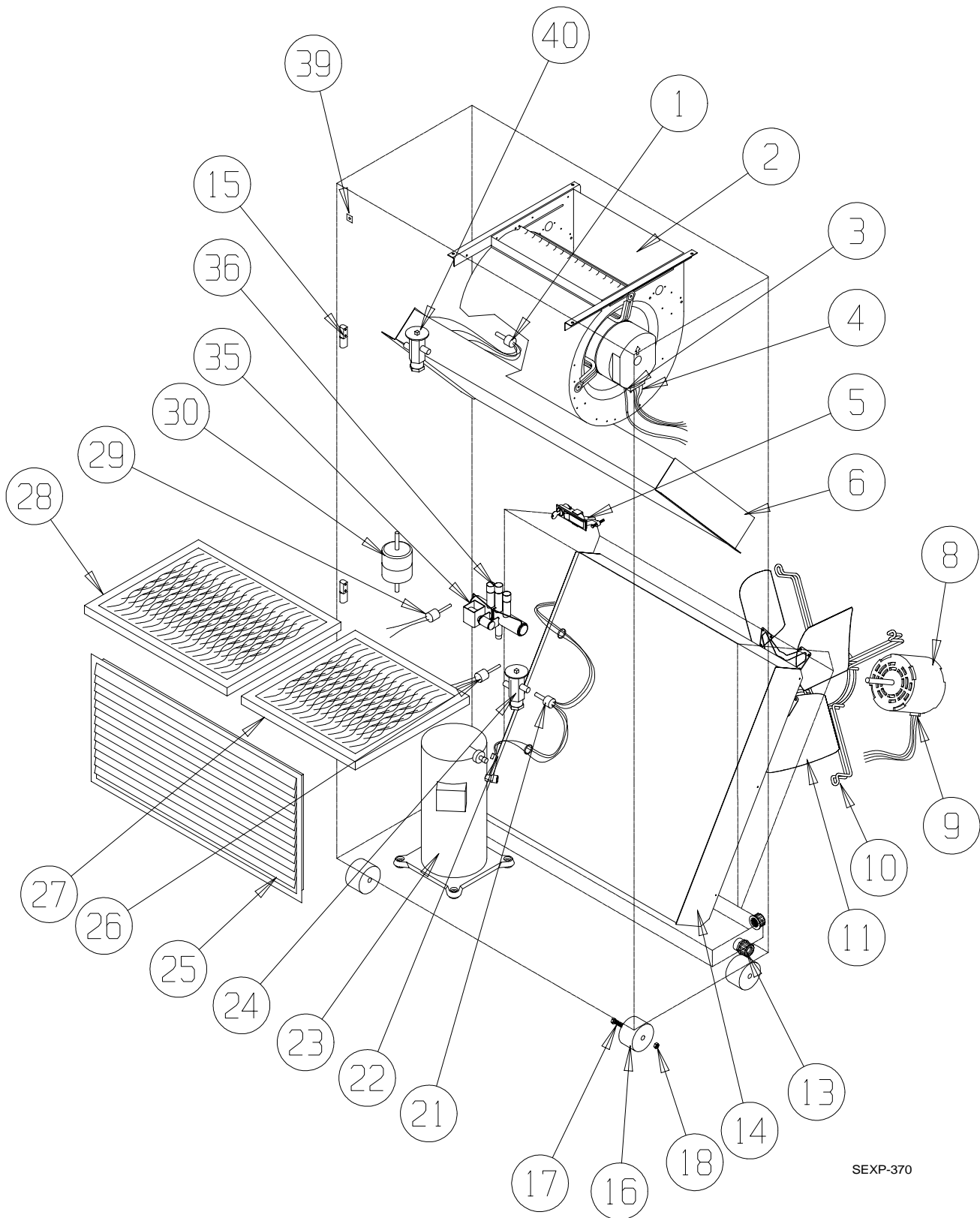

SEXP-370

This Exploded View is referenced in Tables on pages 8, 9, 10 & 11

FUNCTIONAL COMPONENTS

Drawing No.	Part No.	Description	QH242-A	QH242-B	QH242-C	QH302-A	QH302-B	QH302-C	QH362-A	QH362-B	QH362-C	QH422-A	QH422-B	QH422-C
			QH242LA	QH242LB	QH242LC	QH302LA	QH302LB	QH302LC	QH362LA	QH362LB	QH362LC	QH422LA	QH422LB	QH422LC
1	5625-015	Distributor Cooling	X	X	X	X	X	X						
1	5625-020	Distributor Cooling	X	X	X	X	X	X	X	X	X	X	X	X
2	900-225-001	Blower Assembly	X	X	X									
2	900-225-002	Blower Assembly				X	X	X						
2	900-225-004	Blower Assembly							X	X	X	X	X	X
3	3000-1145	Wire Harness High Voltage			X			X			X			X
3	3000-1046	Wire Harness High Voltage	X	X		X	X		X	X		X	X	
4	3000-1042	Wire Harness Low Voltage	X	X	X	X	X	X	X	X	X	X	X	X
5	1171-049	Keylatch/Circuit Breaker Door	X	X	X	X	X	X	X	X	X	X	X	X
6	5060-089	Evaporator Coil	X	X	X	X	X	X						
6	5060-090	Evaporator Coil							X	X	X	X	X	X
8	8103-038	Motor			X			X			X			X
8	8103-037	Motor	X	X		X	X		X	X		X	X	
9	3000-1141	Wire Harness	X	X	X	X	X	X	X	X	X	X	X	X
10	8200-001	Motor Mount	X	X	X	X	X	X	X	X	X	X	X	X
11	5151-050	Fan Blade	X	X	X	X	X	X	X	X	X	X	X	X
13	6094-003	Drain Fitting	1	1	1	1	1	1	1	1	1	1	1	1
14	5051-095	Condenser Coil	X	X	X	X	X	X						
14	5051-096	Condenser Coil							X	X	X	X	X	X
15	5400-005	Hinge	2	2	2	2	2	2	2	2	2	2	2	2
16	1171-035	Wheel	4	4	4	4	4	4	4	4	4	4	4	4
17	1012-129	Bolt - Shoulder	4	4	4	4	4	4	4	4	4	4	4	4
18	1012-224	Nut - Locking	4	4	4	4	4	4	4	4	4	4	4	4
21	5625-008	Distributor - Heating	X	X	X	X	X	X						
21	5625-010	Distributor - Heating							X	X	X	X	X	X
22	910-1257	Defrost Sensor	X	X	X	X	X	X	X	X	X	X	X	X
23	8000-171	Compressor	X											
23	8000-201	Compressor		X										
23	8000-202	Compressor			X									
23	8000-172	Compressor				X								
23	8000-203	Compressor					X							
23	8000-204	Compressor						X						
23	8000-175	Compressor							X					
23	8000-163	Compressor								X				
23	8000-164	Compressor									X			
23	8000-177	Compressor										X		
23	8000-205	Compressor											X	
23	8000-206	Compressor												X
24	5651-137	TXV Heating	X	X	X									
24	5651-138	TXV Heating				X	X	X						
24	5651-102	TXV Heating							X	X	X	X	X	X
25	7051-034	Return Air Grille	X	X	X	X	X	X	X	X	X	X	X	X
26	8406-055	High Pressure Control	X	X	X	X	X	X	X	X	X	X	X	X
27	7004-009	Air Filter	X	X	X	X	X	X	X	X	X	X	X	X
27	7004-032	Filter 2" Fiberglass (Optional)	X	X	X	X	X	X	X	X	X	X	X	X
27	7004-034	Filter 2" Pleated (Optional)	X	X	X	X	X	X	X	X	X	X	X	X
28	7004-010	Air Filter	X	X	X	X	X	X	X	X	X	X	X	X
28	7004-033	Filter 2" Fiberglass (Optional)	X	X	X	X	X	X	X	X	X	X	X	X
28	7004-035	Filter 2" Pleated (Optional)	X	X	X	X	X	X	X	X	X	X	X	X

Continued on Page 7

This Table references Exploded View on Page 7

FUNCTIONAL COMPONENTS

Drawing No.	Part No.	Description	QH242-A	QH242LA	QH242-B	QH242LB	QH242-C	QH242LC	QH302-A	QH302LA	QH302-B	QH302LB	QH302-C	QH302LC	QH362-A	QH362LA	QH362-B	QH362LB	QH362-C	QH362LC	QH422-A	QH422LA	QH422-B	QH422LB	QH422-C	QH422LC
			<i>Continued from page 8</i>																							
29	8406-061	Low Pressure Control	X	X	X	X	X	X	X	X	X	X	X	X	X	X	X	X	X	X	X	X	X	X	X	X
30	5201-009	Filter / Drier	X	X	X	X	X	X	X	X	X	X	X	X	X	X	X	X	X	X	X	X	X	X	X	X
35	5650-020	Reversing Valve	X	X	X				X	X	X															
35	5650-021	Reversing Valve							X	X	X															
35	5650-025	Reversing Valve												X	X	X	X	X	X	X	X	X	X	X	X	X
36	5650-022	Solenoid Coil	X	X	X	X	X	X	X	X	X	X	X	X	X	X	X	X	X	X	X	X	X	X	X	X
39	1012-315	"U" Clip Fastener	10	10	10	10	10	10	10	10	10	10	10	10	10	10	10	10	10	10	10	10	10	10	10	10
40	5651-137	TXV Cooling	X	X	X																					
40	5651-138	TXV Cooling						X	X	X																
40	5651-102	TXV Cooling												X	X	X	X	X	X	X	X	X	X	X	X	X
NS	1804-0108	Low Ambient Control	X	X	X	X	X	X	X	X	X	X	X	X	X	X	X	X	X	X	X	X	X	X	X	X

Drawing No.	Part No.	Description	QH242-A	QH242-B	QH242-C	QH302-A	QH302-B	QH302-C	QH362-A	QH362-B	QH362-C	QH422-A	QH422-B	QH422-C
			NS	4100-105	Wiring Diagram	X			X			X		
NS	4100-207	Wiring Diagram		X			X			X			X	
NS	4100-307	Wiring Diagram			X			X			X			X

Drawing No.	Part No.	Description	QH242LA	QH242LB	QH242LC	QH302LA	QH302LB	QH302LC	QH362LA	QH362LB	QH362LC	QH422LA	QH422LB	QH422LC
			NS	4100-106	Wiring Diagram	X			X			X		
NS	4100-208	Wiring Diagram		X			X			X			X	
NS	4100-308	Wiring Diagram			X			X			X			X

These Tables reference Exploded View on Page 7

FUNCTIONAL COMPONENTS

Drawing No.	Part No.	Description	QH482-A	QH482LA	QH482-B	QH482LB	QH482-C	QH482LC	QH602-A	QH602-B	QH602-C
1	5625-022	Cooling Distributor	X		X		X				
1	5625-018	Cooling Distributor							X	X	X
2	900-225-005	Blower Assembly	X		X		X				
2	900-254-001	Blower Assembly							X	X	X
3	3000-1145	Wire Harness High Voltage					X				X
3	3000-1046	Wire Harness High Voltage	X		X				X	X	
4	3000-1042	Wire Harness Low Voltage	X		X		X		X	X	X
5	1171-049	Keylatch/Circuit Breaker Door	X		X		X		X	X	X
6	5060-095	Evaporator Coil	X		X		X				
6	5060-108	Evaporator Coil							X	X	X
8	8103-038	Motor					X				X
8	8103-021	Motor	X		X				X	X	
9	3000-1141	Wire Harness	X		X		X		X	X	X
10	8200-001	Motor Mount	X		X		X		X	X	X
11	5151-050	Fan Blade	X		X		X		X	X	X
13	6094-003	Drain Fitting	1		1		1		1	1	1
14	5051-104	Condenser Coil	X		X		X		X	X	X
15	5400-005	Hinge	2		2		2		2	2	2
16	1171-035	Wheel	4		4		4		4	4	4
17	1012-129	Bolt - Shoulder	4		4		4		4	4	4
18	1012-224	Nut - Locking	4		4		4		4	4	4
21	5625-007	Distributor - Heating	X		X		X		X	X	X
22	910-1257	Defrost Sensor	X		X		X		X	X	X
23	8000-218	Compressor							X		
23	8000-221	Compressor								X	
23	8000-222	Compressor									X
23	8000-150	Compressor	X								
23	8000-162	Compressor			X						
23	8000-248	Compressor					X				
24	5651-103	TXV Heating	X		X		X				
24	5651-163	TXV Heating							X	X	X
25	7051-039	Return Air Grille	X		X		X		X	X	X
26	8406-055	High Pressure Control	X		X		X		X	X	X
27	7004-009	Air Filter	X		X		X		X	X	X
27	7004-032	Filter 2" Fiberglass (Optional)	X		X		X		X	X	X
27	7004-034	Filter 2" Pleated (Optional)	X		X		X		X	X	X
28	7004-011	Air Filter	X		X		X		X	X	X
28	7004-036	Filter 2" Fiberglass (Optional)	X		X		X		X	X	X
28	7004-037	Filter 2" Pleated (Optional)	X		X		X		X	X	X
29	8406-061	Low Pressure Control	X		X		X		X	X	X
30	5201-009	Filter / Drier	X		X		X		X	X	X
35	5650-025	Reversing Valve	X		X		X		X	X	X
36	5650-022	Solenoid Coil	X		X		X		X	X	X
39	1012-315	"U" Clip Fastener	10		10		10		10	10	10
40	5651-103	TXV Cooling	X		X		X				
NS	1804-0108	Low Ambient Control	X		X		X		X	X	X

These Tables reference Exploded View on Page 7

FUNCTIONAL COMPONENTS

Drawing			QH482-A	QH482-B	QH482-C	QH482LA	QH482LB	QH482LC	QH602-A	QH602-B	QH602-C
No.	Part No.	Description									
NS	4100-105	Wiring Diagram	X						X		
NS	4100-207	Wiring Diagram		X						X	
NS	4100-307	Wiring Diagram			X						X
NS	4100-106	Wiring Diagram				X					
NS	4100-208	Wiring Diagram					X				
NS	4100-308	Wiring Diagram						X			

This Table references Exploded View on Page 7

UPPER CONTROL PANEL COMPONENTS

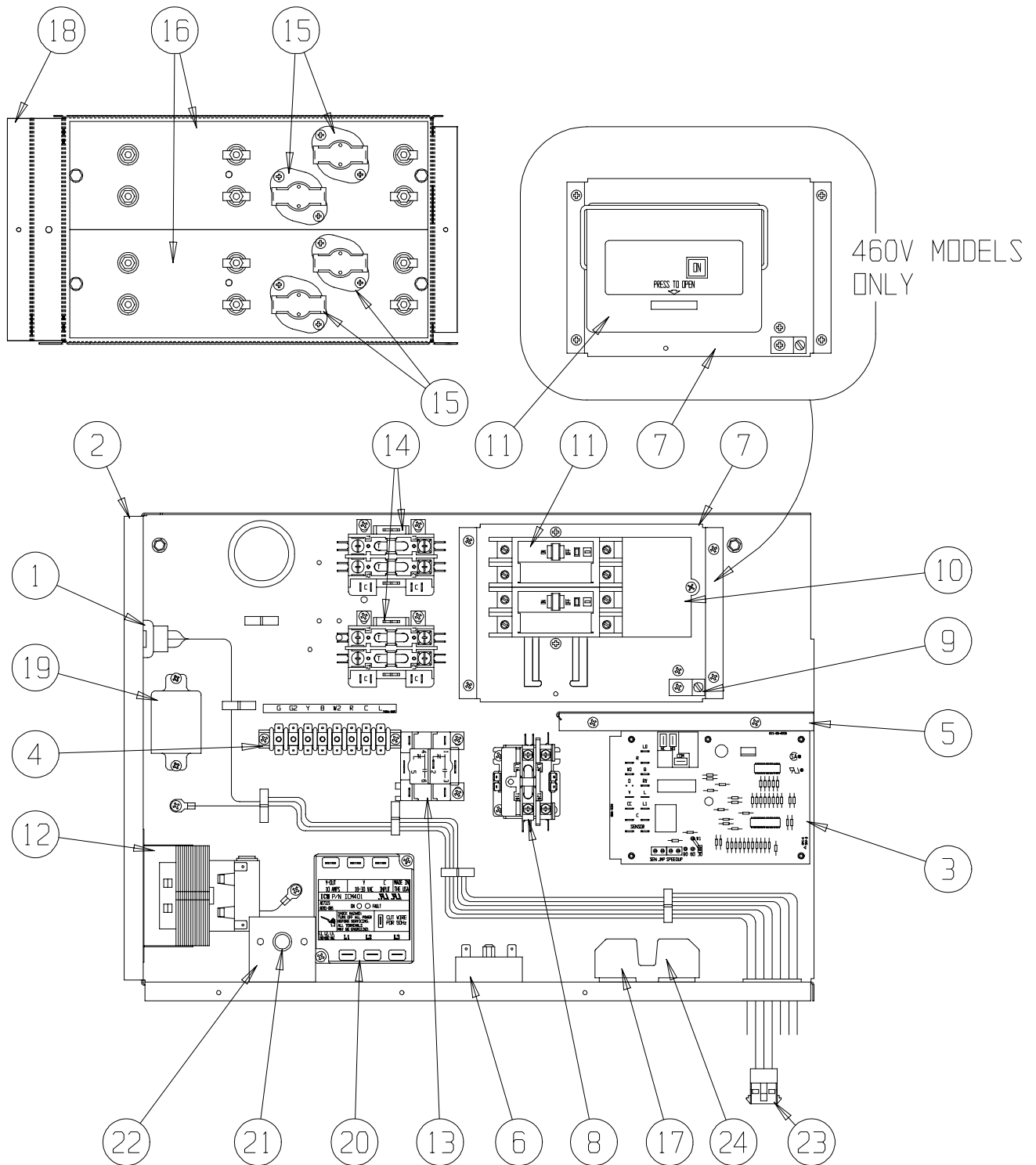

SEXP-373

This Exploded View is referenced in Tables on pages 13,14,15,16,17 & 18

UPPER CONTROL PANEL COMPONENTS

Drawing No.	Part No.	Description	QH242-A02	QH302-A02	QH362-A02	QH422-A02	QH482-A02	QH602-A02	QH242-A05	QH302-A05	QH362-A05	QH422-A05	QH482-A05	QH242LA05	QH302LA05	QH362LA05	QH422LA05	QH482LA05	QH242LA10	QH302LA10	QH362LA10	QH422LA10	QH482LA10	
1	3000-1149	Wire Set P2	X	X	X	X	X	X	X	X	X	X	X	X	X	X	X	X	X	X	X	X	X	X
2	116-241	Control Panel	X	X	X	X	X	X	X	X	X	X	X	X	X	X	X	X	X	X	X	X	X	X
3	8201-069	Heat Pump Control	X	X	X	X	X	X	X	X	X	X	X	X	X	X	X	X	X	X	X	X	X	X
4	8607-022	Terminal Block	X	X	X	X	X	X	X	X	X	X	X	X	X	X	X	X	X	X	X	X	X	X
5	116-242	Box Partition	X	X	X	X	X	X	X	X	X	X	X	X	X	X	X	X	X	X	X	X	X	X
6	8201-078	Low Pressure TDR	X	X	X	X	X	X	X	X	X	X	X	X	X	X	X	X	X	X	X	X	X	X
7	126-267	Circuit Breaker Base	X	X	X	X	X	X	X	X	X	X	X	X	X	X	X	X	X	X	X	X	X	X
8	8401-007	Contactor	X	X	X	X	X	X	X	X	X	X	X	X	X	X	X	X	X	X	X	X	X	X
8	8401-016	Contactor	X	X	X	X	X	X	X	X	X	X	X	X	X	X	X	X	X	X	X	X	X	X
9	8611-006	Ground Lug	X	X	X	X	X	X	X	X	X	X	X	X	X	X	X	X	X	X	X	X	X	X
10	8615-047	Jumper Bar Base																						
11	8615-036	Circuit Breaker 2 Pole 25A Ckt A	X																					
11	8615-037	Circuit Breaker 2 Pole 30A Ckt A																						
11	8615-038	Circuit Breaker 2 Pole 35A Ckt A																						
11	8615-055	Circuit Breaker 2 Pole 40A Ckt A																						
11	8615-039	Circuit Breaker 2 Pole 45A Ckt A																						
11	8615-040	Circuit Breaker 2 Pole 50A Ckt A																						
11	8615-040	Circuit Breaker 2 Pole 50A Ckt B																						
11	8615-041	Circuit Breaker 2 Pole 60A Ckt A																						
12	8407-035	Transformer	X																					
14	8401-006	Contactor 2 Pole 20A																						
15	8402-100	Limits																						

Continued on Page 14

This Table references Exploded View on Page 12

UPPER CONTROL PANEL COMPONENTS

Drawing No.	Part No.	Description	QH242-A02	QH302-A02	QH362-A02	QH422-A02	QH482-A02	QH602-A02	QH242-A05	QH302-A05	QH362-A05	QH422-A05	QH482-A05	QH242LA05	QH302LA05	QH362LA05	QH422LA05	QH482LA05	QH242LA10	QH302LA10	QH362LA10	QH422LA10	QH482LA10	
16	8604-103	Heat Strip 5 KW																						
16	8604-104	Heat Strip 10 KW																						
18	116-191	Heat Strip Wrapper																						
19	8201-048	Relay																						
21	8611-094	Indicator Light																						
22	112-225	Bracket																						
23	3000-1148	Wire Set																						
NS	8201-015	Staging Relay SR																						
NS	132-145	Heat Strip Cover																						
NS	4101-100	Wiring Diagram																						
NS	4101-101	Wiring Diagram																						
NS	4101-102	Wiring Diagram																						
NS	4101-103	Wiring Diagram																						
NS	4101-104	Wiring Diagram																						
NS	4101-105	Wiring Diagram																						
NS	4101-106	Wiring Diagram																						

Continued From Page 13

NS = Not Shown

This Table references Exploded View on Page 12

UPPER CONTROL PANEL COMPONENTS

Drawing No.	Part No.	Description	QH42-B0Z	QH302-B0Z	QH362-B0Z	QH422-B0Z	QH482-B0Z	QH242-B06	QH302-B06	QH362-B06	QH422-B06	QH482-B06	QH242LB06	QH302LB06	QH362LB06	QH422LB06	QH482LB06	QH242LB09	QH302LB09	QH362LB09	QH422LB09	QH482LB09	
1	3000-1049	Wire Set PL2	X	X	X	X	X	X	X	X	X	X	X	X	X	X	X	X	X	X	X	X	X
2	116-241	Control Panel	X	X	X	X	X	X	X	X	X	X	X	X	X	X	X	X	X	X	X	X	X
3	8201-069	Heat Pump Control	X	X	X	X	X	X	X	X	X	X	X	X	X	X	X	X	X	X	X	X	X
4	8607-022	Terminal Block	X	X	X	X	X	X	X	X	X	X	X	X	X	X	X	X	X	X	X	X	X
5	116-242	Box Partition	X	X	X	X	X	X	X	X	X	X	X	X	X	X	X	X	X	X	X	X	X
6	8201-078	Low Pressure Bypass TDR	X	X	X	X	X	X	X	X	X	X	X	X	X	X	X	X	X	X	X	X	X
7	126-267	Circuit Breaker Base	X	X	X	X	X	X	X	X	X	X	X	X	X	X	X	X	X	X	X	X	X
8	8401-002	Contactors	X	X	X	X	X	X	X	X	X	X	X	X	X	X	X	X	X	X	X	X	X
9	8611-006	Ground Lug	X	X	X	X	X	X	X	X	X	X	X	X	X	X	X	X	X	X	X	X	X
11	8615-054	Circuit Breaker 3 Pole 20A	X	X	X	X	X	X	X	X	X	X	X	X	X	X	X	X	X	X	X	X	X
11	8615-051	Circuit Breaker 3 Pole 25A																					
11	8615-052	Circuit Breaker 3 Pole 30A																					
11	8615-042	Circuit Breaker 3 Pole 35A																					
11	8615-043	Circuit Breaker 3 Pole 40A																					
11	8615-044	Circuit Breaker 3 Pole 45A																					
11	8615-045	Circuit Breaker 3 Pole 50A																					
11	8615-046	Circuit Breaker 3 Pole 60A																					
12	8407-035	Transformer	X	X	X	X	X	X	X	X	X	X	X	X	X	X	X	X	X	X	X	X	X
14	8401-006	Contactors 2 Pole 20A																					
15	8402-100	Limits																					

Continued on Page 16

This Table references Exploded View on Page 12

UPPER CONTROL PANEL COMPONENTS

Drawing No.	Part No.	Description	QH242-B0Z	QH302-B0Z	QH362-B0Z	QH422-B0Z	QH482-B06	QH242-B06	QH302-B06	QH362-B06	QH422-B06	QH482-B06	QH242-B06	QH302-B06	QH362-B06	QH422-B06	QH482-B06	QH242-B09	QH302-B09	QH362-B09	QH422-B09	QH482-B09	QH242-B09	QH302-B09	QH362-B09	QH422-B09	QH482-B09												
16	8604-105	Heat Strip 6 KW						X	X																														
16	8604-106	Heat Strip 9 KW						X	X																														
18	116-191	Heat Strip Wrapper						X	X																														
19	8201-048	Relay						X	X																														
20	8201-085	Phase Monitor						X	X																														
21	8611-094	Indicator Light	X	X	X	X	X	X	X																														
22	112-225	Bracket	X	X	X	X	X	X	X																														
23	3000-1148	Wire Set PL3	X	X	X	X	X	X	X																														
NS	8201-015	Staging Relay SR																																					
NS	132-145	Heat Strip Cover						X	X																														
NS	4101-200	Wiring Diagram	X	X	X	X	X	X	X																														
NS	4101-201	Wiring Diagram						X	X																														
NS	4101-202	Wiring Diagram						X	X																														
NS	4101-203	Wiring Diagram																																					
NS	4101-204	Wiring Diagram																																					

Continued from Page 15

NS = Not Shown

This Table references Exploded View on Page 12

UPPER CONTROL PANEL COMPONENTS

Drawing No.	Part No.	Description	QH242-C02	QH302-C02	QH362-C02	QH422-C02	QH482-C02	QH602-C02	QH242-C06	QH302-C06	QH362-C06	QH422-C06	QH482-C06	QH242-C09	QH302-C09	QH362-C09	QH422-C09	QH482-C09
1	3000-1049	Wire Set PL2	X					X										
2	116-241	Control Panel	X	X				X										
3	8201-069	Heat Pump Control	X	X				X										
4	8607-022	Terminal Block	X	X				X										
5	1116-242	Box Partition	X	X				X										
6	8201-078	Low Pressure Bypass TDR	X	X				X										
7	126-269	Pull Disconnect Base	X	X				X										
8	8401-002	Contactors	X	X				X										
9	8611-006	Ground Lug	X	X				X										
11	8615-053	Pull Disconnect	X	X				X										
12	8407-035	Transformer	X	X				X										
13	8201-009	Relay OMR	X	X				X										
14	8401-002	Contactors 3 Pole 25A						X										
15	8402-100	Limits						2	2	2	4	2	2	2	2	2	2	2

Continued on Page 18

This Table references Exploded View on Page 12

UPPER CONTROL PANEL COMPONENTS

Drawing No.	Part No.	Description	QH242-C0Z QH302-C0Z QH362-C0Z QH422-C0Z QH482-C0Z	QH602-C0Z	QH242-C06 QH302-C06 QH362-C06 QH422-C06 QH482-C06	QH242-C09 QH302-C09 QH362-C09 QH422-C09 QH482-C09	QH302-C12	QH362-C15 QH422-C15 QH482-C15	QH242LC06 QH302LC06 QH362LC06 QH422LC06 QH482LC06	QH242LC09 QH302LC09 QH362LC09 QH422LC09 QH482LC09
16	8604-107	Heat Strip 6 KW 480V					2	X	X	X
16	8604-108	Heat Strip 9 KW 480V				X		X	X	X
17	8614-041	Fuse Holder	X			X		X	X	X
18	116-191	Heat Strip Wrapper				X		X	X	X
19	8201-048	Relay				X		X	X	X
20	8201-085	Phase Monitor	X			X		X	X	X
21	8611-094	Indicator Light	X			X		X	X	X
22	112-225	Bracket	X			X		X	X	X
23	3000-1148	Wire Set PL3	X			X		X	X	X
NS	8407-052	Transformer Stepdown 1.0 KVA	X			X		X	X	X
NS	8407-053	Transformer Stepdown 1.5 KVA	X			X		X	X	X
NS	8407-054	Transformer Stepdown 2.0 KVA	X			X		X	X	X
NS	8201-015	Staging Relay SR							X	X
24	8614-042	Fuses Class CC 7A ①		2						
24	8614-046	Fuses Class CC 5A ②		2			2	2	2	2
24	8614-047	Fuses Class CC 3.2A ③		2			2	2	2	2
NS	132-145	Heat Strip Cover				X		X	X	X
NS	4101-300	Wiring Diagram	X							
NS	4101-301	Wiring Diagram				X				
NS	4101-302	Wiring Diagram						X		
NS	4101-303	Wiring Diagram								
NS	4101-304	Wiring Diagram					X		X	X

Continued from Page 17

① 7 Amp fuses used with 2.0 KVA transformer. ② 5 Amp fuses used with 1.5 KVA transformer. ③ 3.2 Amp fuses used with 1KVA transformer.

NS = Not Shown

This Table references Exploded View on Page 12

LOWER CONTROL PANEL COMPONENTS

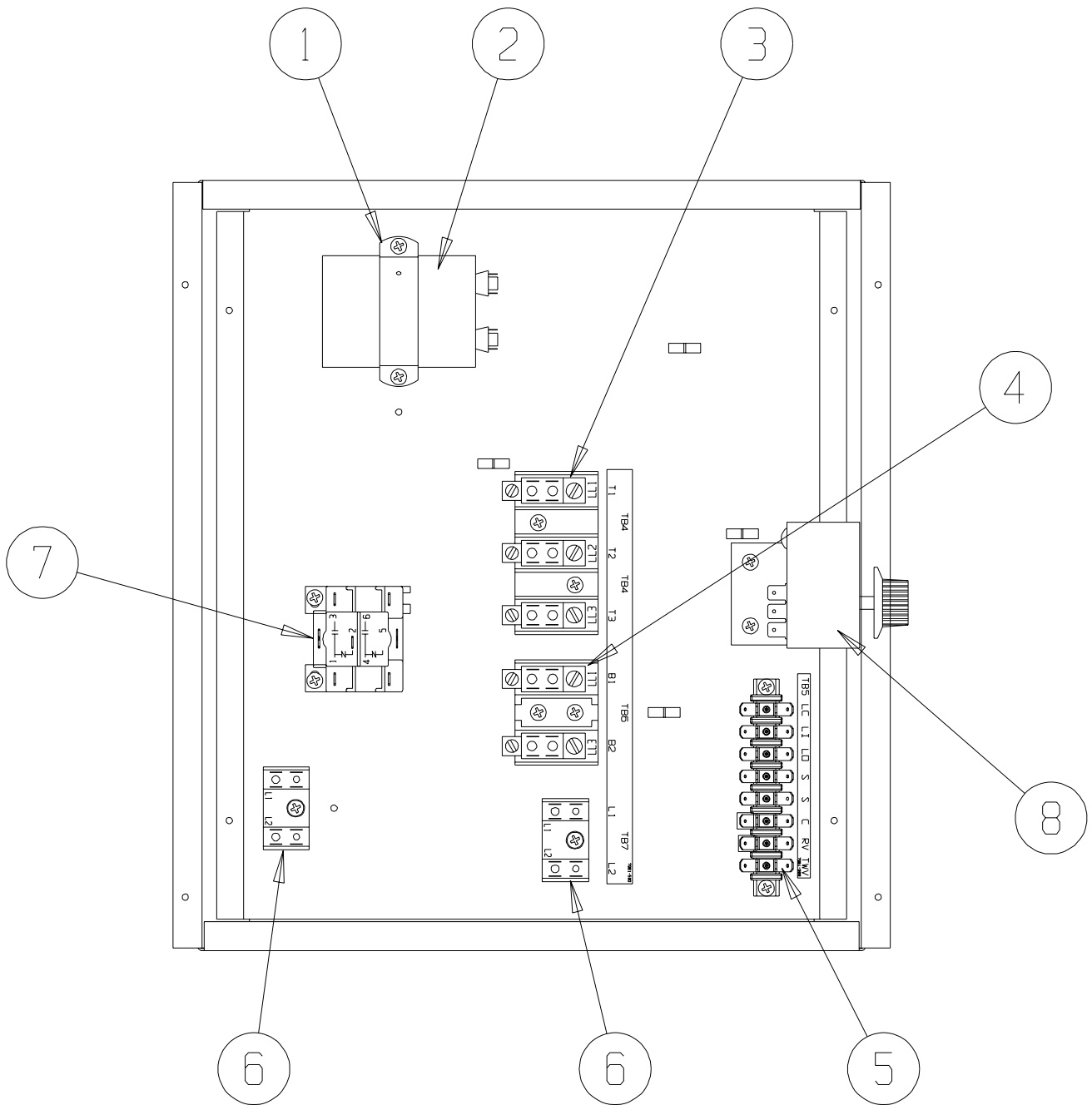

sexp-374

LOWER CONTROL PANEL COMPONENTS

Drawing			QH242-A, LA	QH302-A, LA	QH362-A, LA	QH422-A, LA	QH482-A, LA	QH602-A	QH242-B, LA	QH302-B, LA	QH362-B, LA	QH422-B, LA	QH482-B, LA	QH602-B, LA	QH242-C, LA	QH302-C, LA	QH362-C, LA	QH422-C, LA	QH482-C, LA	QH602-C, LA
No.	Part No.	Description																		
1	8552-008	Capacitor Strap	X	X	X	X	X	X												
1	8552-003	Capacitor Strap							X										X	
2	8552-002	Compressor Capacitor							X										X	
2	8552-050	Compressor Capacitor	X																	
2	8552-052	Compressor Capacitor		X																
2	8552-063	Compressor Capacitor			X															
2	8552-062	Compressor Capacitor				X	X													
2	8552-076	Compressor Capacitor						X												
3	8607-014	Terminal Block 3 Ter								X									X	
4	8607-013	Terminal Block 2 Ter	X	X	X	X	X	X												X
5	8607-022	Terminal Block 8 Pos	X	X	X	X	X	X		X										X
6	8607-017	Terminal Block 2 Ter	X	X	X	X	X	X		X										X
7	8201-032	Low Ambient Bypass Relay (Opt.)	X	X	X	X	X	X		X										X
8	8408-034	Outdoor Thermostat ①	X	X	X	X	X	X		X										X

① Optional on standard models. Standard on low ampacity models.

BLOWER ASSEMBLY COMPONENTS

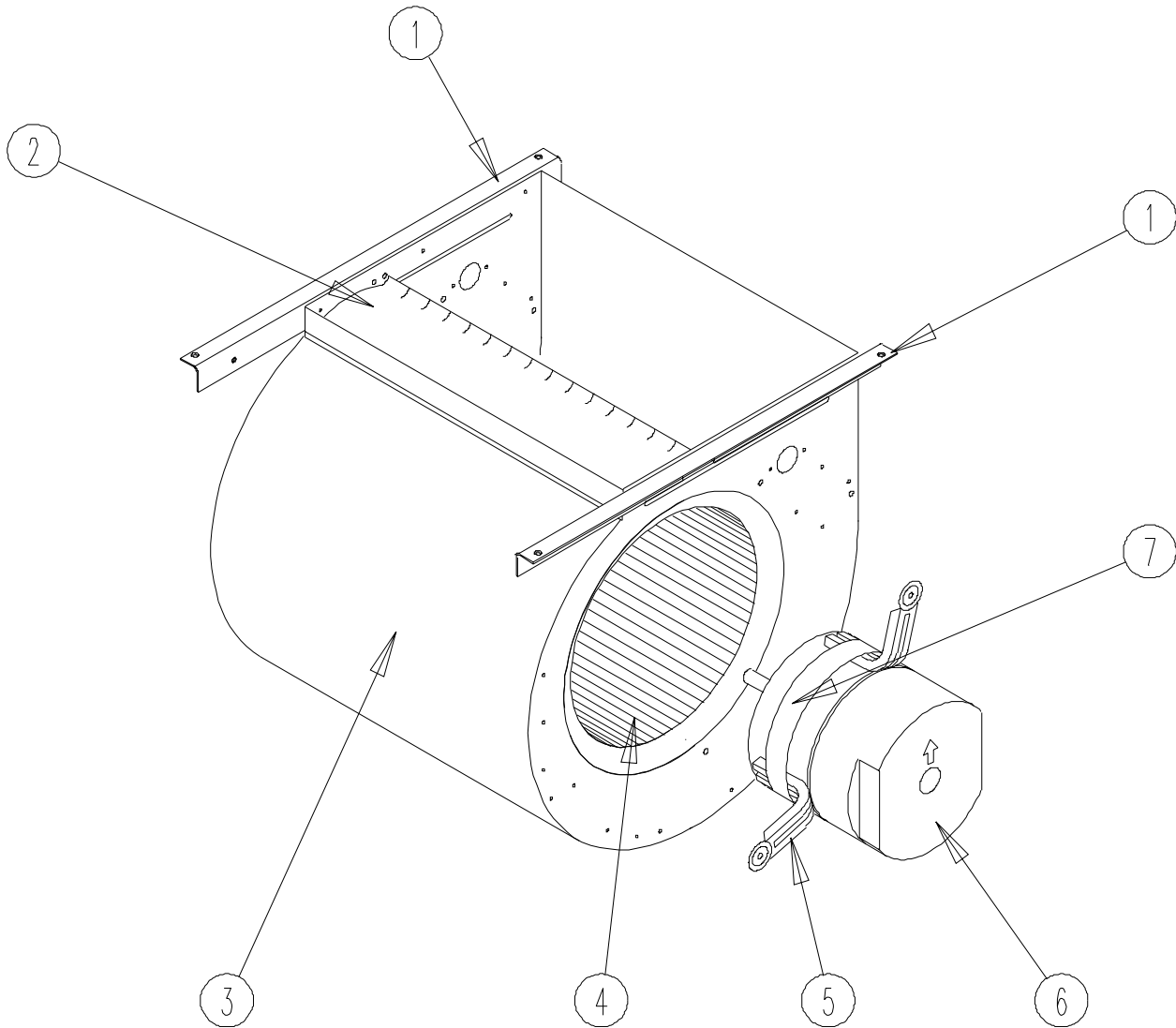

SEXP-245

BLOWER ASSEMBLY COMPONENTS

Drawing No.	Part No.	Description	900-225-001	900-225-002	900-225-004	900-225-005	900-254-001
1	104-980	Blower Angle	2	2	2	2	2
2	144-131	Diffuser	X	X	X	X	X
3	151-110	Blower Housing	X	X	X	X	X
4	5152-061	Blower Wheel	X	X	X	X	X
5	8200-034	Motor Mount Arm	3	3	3	3	3
6	8106-035-0003	Motor	X				
6	8106-035-0004	Motor		X			
6	8106-035-0005A	Motor			X		
6	8106-035-0013	Motor				X	
6	8107-009-0024	Motor					X
7	8200-033	Motor Mount Band	X	X	X	X	X

OPTIONAL CLIMATE CONTROLS

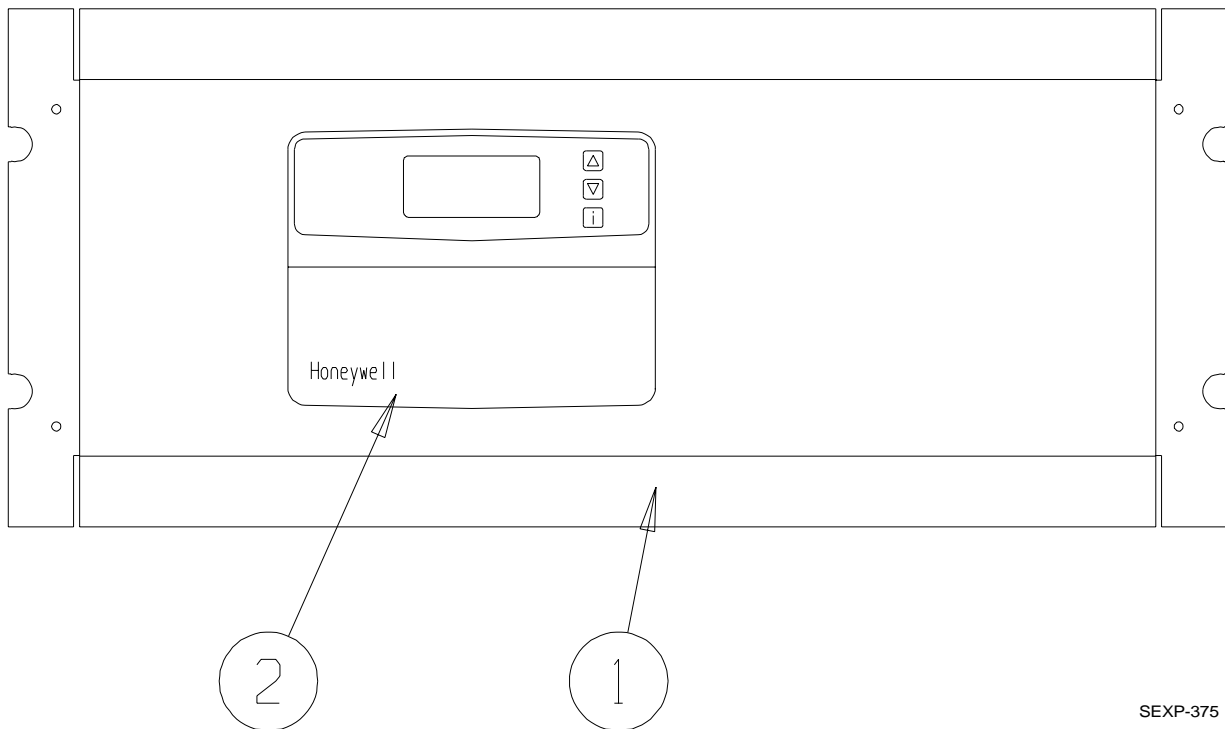
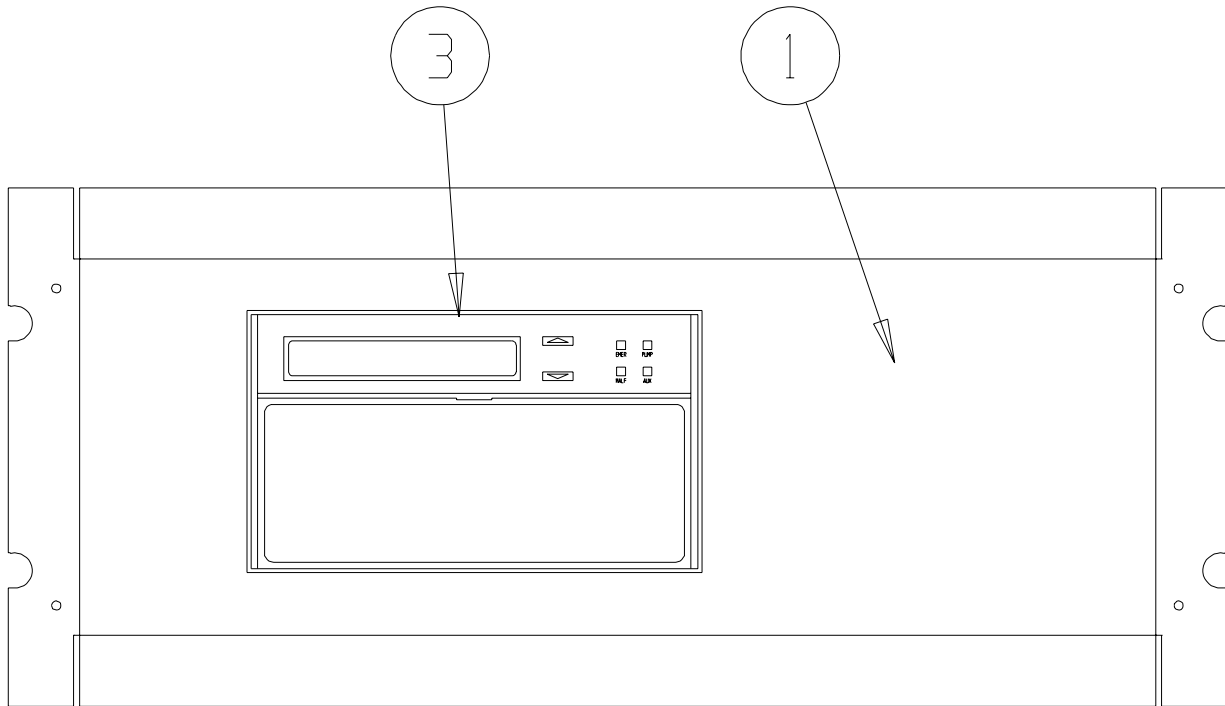

SEXP-375

OPTIONAL CLIMATE CONTROLS

Drawing No.	Part No.	Description	QH242, QH302 QH362, QH422			QH482, QH602		
			Option X	Option A	Option D	Option X	Option A	Option D
1	127-313-* ①	Thermostat Plate	X			X		
1	127-308-* ①	Thermostat Plate		X	X		X	X
2	8403-042	Electronic / Non-Programmable / Manual / Auto Change Over		X		X		
3	8403-034	Electronic / Programmable / Manual / Auto Change Over			X			X
NS	3000-1157	Wire Harness, Low Voltage Terminal Strip to PL2	X			X		
NS	3000-1156	Wire Harness, Thermostat to PL2		X			X	
NS	3000-1155	Wire Harness, Thermostat to PL2			X			X
NS	8607-019	Low Voltage Terminal Strip	X	X		X	X	
NS	4102-020	Wiring Diagram	X			X		
NS	4102-021	Wiring Diagram		X			X	
NS	4102-022	Wiring Diagram			X			X

① Exterior cabinet parts are manufactured with various color options. To insure that you receive the proper color, you must include the complete models and serial number of the unit for which parts are being ordered.

NS Not Shown

CLIMATE CONTROL OPTION NOMENCLATURE AS SHOWN IN UNIT MODEL NUMBER

QH 362 - A 09 X X X X X X

- X – None
- A – Electronic, non-programmable, manual change over
- D – Electronic, programmable, manual/auto change over

WALL SLEEVE CABINET COMPONENTS

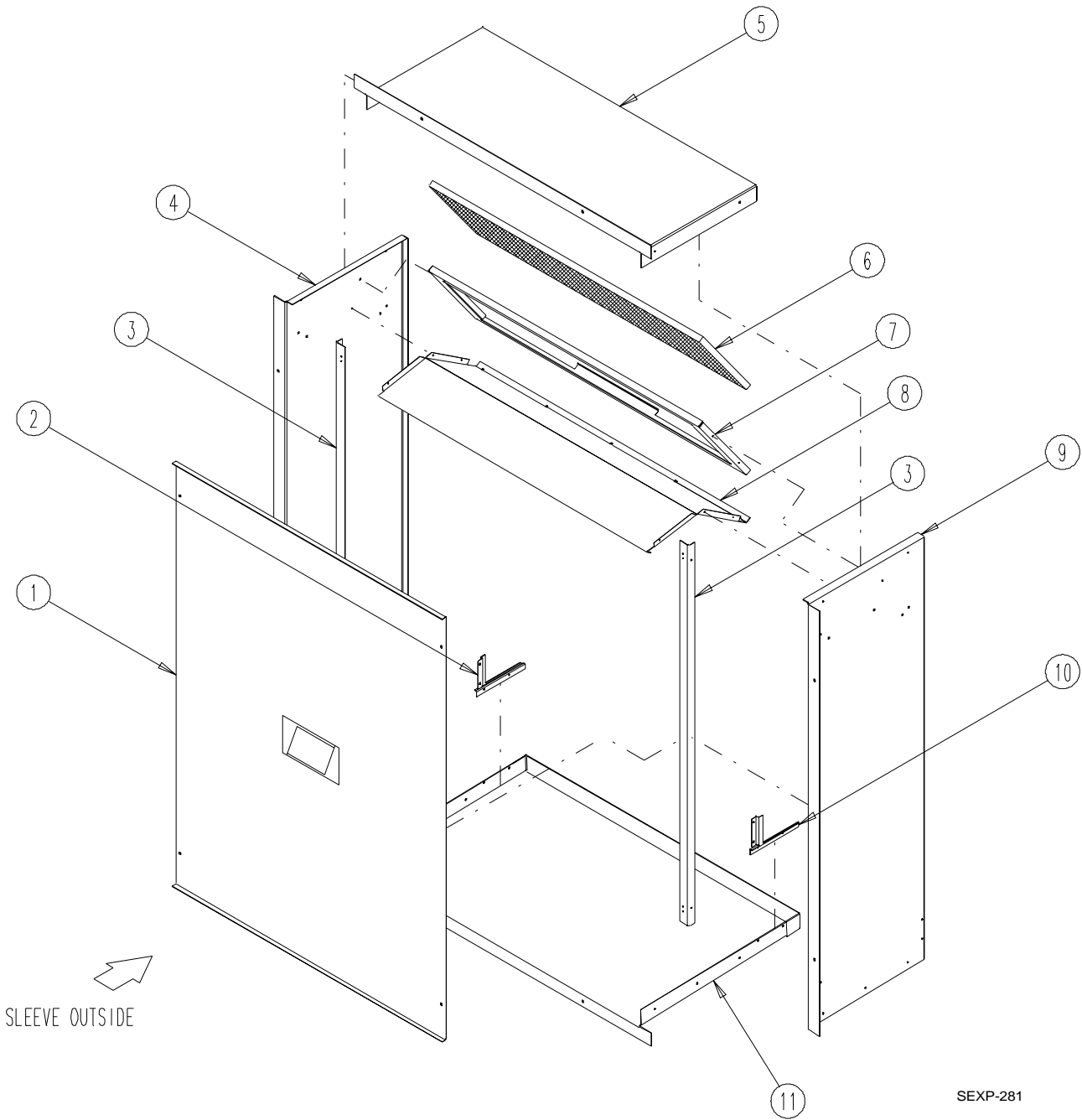

WALL SLEEVE CABINET COMPONENTS

Drawing No.	Part No.	Description	QWS42	QWS42-16	QWS48	QWS48-16
1	142-056	Cover	X	X		
1	142-068	Cover			X	X
2	136Y361	Left Side Seal Angle	X	X	X	X
3	104-988	Angle	2	2	2	2
4	110Y045	Left Side	X		X	
4	110Y048	Left Side		X		X
5	110-047	Top	X			
5	110-050	Top		X		
5	110-056	Top			X	
5	110-070	Top				X
6	7003-044	Mist Eliminator	X	X	X	X
7	130-120	Filter Tray	X	X		
7	130-128	Filter Tray			X	X
8	120-305	Partition	X			
8	120-309	Partition		X		
8	120-322	Partition			X	
8	120-348	Partition				X
9	110X045	Right Side	X		X	
9	110X048	Right Side		X		X
10	136X361	Right Side Seal Angle	X	X		
10	136-404	Right Side Seal Angle			X	X
11	111-046	Base	X			
11	111-049	Base		X		
11	111-055	Base			X	
11	111-071	Base				X