

# REPLACEMENT PARTS MANUAL

# QTEC SERIES PACKAGED HEAT PUMP

Models:

QH242D    QH302D  
QH362D    QH422D  
QH482D

## General Notes

- Revised and/or additional pages may be issued from time to time.
- A complete and current manual consists of pages shown in the following contents section.

## Contents

| Description                         | Page |
|-------------------------------------|------|
| Cabinet Components                  |      |
| ♦ Exploded View .....               | 1    |
| ♦ Usage List .....                  | 2    |
| ♦ Usage List .....                  | 3    |
| ♦ Usage List .....                  | 4    |
| ♦ Usage List .....                  | 5    |
| ♦ Blank Page .....                  | 6    |
| Functional Components               |      |
| ♦ Exploded View .....               | 7    |
| ♦ Usage List .....                  | 8    |
| ♦ Usage List .....                  | 9    |
| ♦ Usage List .....                  | 10   |
| Upper Control Panel Components      |      |
| ♦ Exploded View .....               | 11   |
| ♦ Usage List .....                  | 12   |
| ♦ Usage List .....                  | 13   |
| ♦ Usage List .....                  | 14   |
| Lower Control Panel Components      |      |
| ♦ Exploded View .....               | 15   |
| ♦ Usage List .....                  | 16   |
| Dehumidification Module Components  |      |
| ♦ Exploded View .....               | 16   |
| ♦ Usage List .....                  | 16   |
| Blower Assembly Components          |      |
| ♦ Exploded View .....               | 17   |
| ♦ Usage List .....                  | 18   |
| Optional Climate Control Components |      |
| ♦ Exploded View .....               | 19   |
| ♦ Usage List .....                  | 20   |
| Wall Sleeve Cabinet Components      |      |
| ♦ Exploded View .....               | 21   |
| ♦ Usage List .....                  | 22   |



**BARD MANUFACTURING COMPANY**  
Bryan, Ohio 43506  
*Since 1914...Moving ahead, just as planned.*

Manual: 2110-534B  
Supersedes: 2110-534A  
File: Tab 14  
Date: 05-03-01



# CABINET COMPONENTS

| Drawing No. | Part No.    | Description                         | QH242DA, B | QH242DC | QH302DA, B | QH302DC | QH362DA, B | QH362DC | QH422DA, B | QH422DC |
|-------------|-------------|-------------------------------------|------------|---------|------------|---------|------------|---------|------------|---------|
| 1           | 506-225     | Top Assembly                        | X          | X       | X          | X       | X          | X       | X          | X       |
| 2           | 110-044     | Outlet Duct Flange                  | 2          | 2       | 2          | 2       | 2          | 2       | 2          | 2       |
| 3           | See Page 12 | Heater Package Assembly (Optional)  | X          | X       | X          | X       | X          | X       | X          | X       |
| 4           | 117-187     | Low Voltage Box Assembly (Optional) | X          | X       | X          | X       | X          | X       | X          | X       |
| 5           | 136-359     | T. K. O. Plate                      | X          | X       | X          | X       | X          | X       | X          | X       |
| 6           | 534-191     | Evaporator Coil Shield – Right      | X          | X       | X          | X       | X          | X       | X          | X       |
| 7           | 508-133     | Back Assembly                       | X          | X       | X          | X       | X          | X       | X          | X       |
| 8           | 538-106     | Fresh Air Damper Assembly           | X          | X       | X          | X       | X          | X       | X          | X       |
| 9           | 523-104     | Evaporator Drain Pan Assembly       | X          | X       | X          | X       | X          | X       | X          | X       |
| 10          | 134-154     | Wire Channel                        | X          | X       | X          | X       | X          | X       | X          | X       |
| 11          | 140X277     | Right Evaporator Support            | X          | X       | X          | X       | X          | X       | X          | X       |
| 12          | 124-032     | Fan Shroud Back                     | X          | X       | X          | X       | X          | X       | X          | X       |
| 13          | 142-055     | Condenser Coil Fill                 | X          | X       | X          | X       | X          | X       | X          | X       |
| 14          | 520-346     | Condenser Partition Assembly        | X          | X       | X          | X       | X          | X       | X          | X       |
| 15          | 124X043     | Fan Shroud Right Side               | X          | X       | X          | X       | X          | X       | X          | X       |
| 16          | 124Y043     | Fan Shroud Left Side                | X          | X       | X          | X       | X          | X       | X          | X       |
| 17          | 140-229     | Condenser Coil Support              | 2          | 2       | 2          | 2       | 2          | 2       | 2          | 2       |
| 18          | 135-177-* ① | Side Trim – Lower                   | 2          | 2       | 2          | 2       | 2          | 2       | 2          | 2       |
| 19          | 500-392-* ① | Right Side Assembly                 | X          | X       | X          | X       | X          | X       | X          | X       |
| 20          | 140-227     | Subcooling Loop Hold Down           | 3          | 3       | 3          | 3       | 3          | 3       | 3          | 3       |
| 21          | 123-094     | Condenser Drain Pan Assembly        | X          | X       | X          | X       | X          | X       | X          | X       |
| 22          | 527-309-X   | Lower Base Assembly                 | X          | X       | X          | X       | X          | X       | X          | X       |
| 23          | 102-415     | Pile Seal Offset                    | 2          | 2       | 2          | 2       | 2          | 2       | 2          | 2       |
| 24          | 117-240     | Lower Control Panel Plate           | X          | X       | X          | X       | X          | X       | X          | X       |
| 25          | 135-189     | Base Shield                         | X          | X       | X          | X       | X          | X       | X          | X       |
| 26          | 140-276     | Lower Roller Support                | 2          | 2       | 2          | 2       | 2          | 2       | 2          | 2       |
| 27          | See Page 7  | Control Panel Components            | X          | X       | X          | X       | X          | X       | X          | X       |
| 28          | 133-164     | Control Panel Door – Lower          | X          | X       | X          | X       | X          | X       | X          | X       |
| 29          | 534-155-6   | Base Trim Assembly                  | X          | X       | X          | X       | X          | X       | X          | X       |
| 30          | 140-230     | Drain Pan Support                   | X          | X       | X          | X       | X          | X       | X          | X       |
| 31          | 552-332-* ① | Condenser Door Assembly             | X          | X       | X          | X       | X          | X       | X          | X       |
| 32          | 140-280     | Upper Roller Support                | 2          | 2       | 2          | 2       | 2          | 2       | 2          | 2       |
| 33          | 536-351     | Condenser Blank Off Plate           | X          | X       | X          | X       | X          | X       | X          | X       |
| 34          | 552-330-* ① | Filter Door Assembly                | X          | X       | X          | X       | X          | X       | X          | X       |
| 35          | 152-336-* ① | Circuit Breaker Door                | X          | X       | X          | X       | X          | X       | X          | X       |
| 36          | 116-238     | Lower Control Panel Bottom          | X          | X       | X          | X       | X          | X       | X          | X       |
| 37          | 132-166     | Pull Disconnect Door Inner          | X          | X       | X          | X       | X          | X       | X          | X       |
| 37          | 132-165     | Circuit Breaker Door Inner          | X          | X       | X          | X       | X          | X       | X          | X       |
| 38          | 113-281     | Left Filter Bracket                 | X          | X       | X          | X       | X          | X       | X          | X       |
| 39          | 552-331-* ① | Blower Door Assembly                | X          | X       | X          | X       | X          | X       | X          | X       |

*Continued on Page 3*

- ① Exterior cabinet parts are manufactured with various color options. To insure that you receive the proper color, you must include the complete models and serial number of the unit for which parts are being ordered.

**This Table references Exploded View on Page 1**

# CABINET COMPONENTS

| Drawing No.                  | Part No.              | Description                    | QH242DA, DB | QH242DC | QH302DA, DB | QH302DC | QH362-D, DB | QH362DC | QH422DA, DB | QH422DC |
|------------------------------|-----------------------|--------------------------------|-------------|---------|-------------|---------|-------------|---------|-------------|---------|
| <i>Continued from Page 2</i> |                       |                                |             |         |             |         |             |         |             |         |
| 40                           | 113-282               | Right Filter Bracket           | X           | X       | X           | X       | X           | X       | X           | X       |
| 41                           | 140Y277               | Left Evaporator Support        | X           | X       | X           | X       | X           | X       | X           | X       |
| 42                           | 117-243               | Relay Control Panel            | X           | X       | X           | X       | X           | X       | X           | X       |
| 43                           | 500-391- <sup>Ⓞ</sup> | Left Side Assembly             | X           | X       | X           | X       | X           | X       | X           | X       |
| 44                           | 113-142               | Expansion Valve Mounting Plate | X           | X       | X           | X       | X           | X       | X           | X       |
| 45                           | 135-165- <sup>Ⓞ</sup> | Base Trim Extension            | 2           | 2       | 2           | 2       | 2           | 2       | 2           | 2       |
| 46                           | 112X283               | Center Right Filter Bracket    | X           | X       | X           | X       | X           | X       | X           | X       |
| 46                           | 112Y283               | Center Left Filter Bracket     | X           | X       | X           | X       | X           | X       | X           | X       |
| 47                           | See Page 17           | Pull Disconnect Assembly       |             | X       |             | X       |             | X       |             | X       |
| 47                           | See Page 15           | Circuit Breaker Box Assembly   | X           |         | X           |         | X           |         | X           |         |
| 48                           | 112-229               | Heatstrip Bracket              | X           | X       | X           | X       | X           | X       | X           | X       |
| 49                           | 112-234               | Mounting Bracket               | 2           | 2       | 2           | 2       | 2           | 2       | 2           | 2       |
| 50                           | 135-178- <sup>Ⓞ</sup> | Side Trim – Upper              | 2           | 2       | 2           | 2       | 2           | 2       | 2           | 2       |
| 51                           | See page 13           | Thermostat Mounting Plate      | X           | X       | X           | X       | X           | X       | X           | X       |
| 52                           | 104-1096              | Left Thermostat Support Angle  | X           | X       | X           | X       | X           | X       | X           | X       |
| 53                           | 103-442               | Thermostat Support Offset      | 2           | 2       | 2           | 2       | 2           | 2       | 2           | 2       |
| 54                           | 104-1097              | Front Filter Angle             | X           | X       | X           | X       | X           | X       | X           | X       |
| 55                           | 104-1096              | Right Thermostat Support Angle | X           | X       | X           | X       | X           | X       | X           | X       |
| 56                           | 102-434               | Sleeve Offset                  | X           | X       | X           | X       | X           | X       | X           | X       |
| 57                           | 117-237               | Lower Control Panel Top        | X           | X       | X           | X       | X           | X       | X           | X       |
| 58                           | 534-190               | Evaporator Coil Shield – Left  | X           | X       | X           | X       | X           | X       | X           | X       |
| 59                           | 103-443               | Door Latch Offset              | X           | X       | X           | X       | X           | X       | X           | X       |
| 60                           | 140-282               | Transformer Support            |             | X       |             | X       |             | X       |             | X       |

- <sup>Ⓞ</sup> Exterior cabinet parts are manufactured with various color options. To insure that you receive the proper color, you must include the complete models and serial number of the unit for which parts are being ordered.

This Table references Exploded View on Page 1

# CABINET COMPONENTS

| Drawing<br>No. | Part No.    | Description                         | QH482DA, DB<br>QH602DA, DB | QH482DC |
|----------------|-------------|-------------------------------------|----------------------------|---------|
| 1              | 506-226     | Top Assembly                        | X                          | X       |
| 2              | 110-044     | Outlet Duct Flange                  | 2                          | 2       |
| 3              | See Page 12 | Heater Package Assembly (Optional)  | X                          | X       |
| 4              | 117-187     | Low Voltage Box Assembly (Optional) | X                          | X       |
| 5              | 136-359     | T. K. O. Plate                      | X                          | X       |
| 6              | 534-195     | Evaporator Coil Shield - Right      | X                          | X       |
| 7              | 508-149     | Back Assembly                       | X                          | X       |
| 8              | 538-106     | Fresh Air Damper Assembly           | X                          | X       |
| 9              | 523-105     | Evaporator Drain Pan Assembly       | X                          | X       |
| 10             | 134-154     | Wire Channel                        | X                          | X       |
| 11             | 140X277     | Right Evaporator Support            | X                          | X       |
| 12             | 124-046     | Fan Shroud Back                     | X                          | X       |
| 13             | 143-066     | Condenser Coil Fill                 | X                          | X       |
| 14             | 520-347     | Condenser Partition Assembly        | X                          | X       |
| 15             | 124-041     | Fan Shroud Right Side               | X                          | X       |
| 16             | 124-045     | Fan Shroud Left Side                | X                          | X       |
| 17             | 140-229     | Condenser Coil Support              | 2                          | 2       |
| 18             | 135-177-* ① | Side Trim - Lower                   | 2                          | 2       |
| 19             | 500-392-* ① | Right Side Assembly                 | X                          | X       |
| 20             | 140-227     | Subcooling Loop Hold Down           | 3                          | 3       |
| 21             | 123-099     | Condenser Drain Pan Assembly        | X                          | X       |
| 22             | 527-294     | Lower Base Assembly                 | X                          | X       |
| 23             | 102-415     | Pile Seal Offset                    | 2                          | 2       |
| 24             | 117-240     | Lower Control Panel Plate           | X                          | X       |
| 25             | 134-194     | Base Shield                         | X                          | X       |
| 26             | 140-276     | Lower Roller Support                | 2                          | 2       |
| 27             | See Page 7  | Control Panel Components            | X                          | X       |
| 28             | 133-164     | Control Panel Door - Lower          | X                          | X       |
| 29             | 534-174-6   | Base Trim Assembly                  | X                          | X       |
| 30             | 140-230     | Drain Pan Support                   | X                          | X       |
| 31             | 552-334-* ① | Condenser Door Assembly             | X                          | X       |
| 32             | 140-280     | Upper Roller Support                | 2                          | 2       |
| 33             | 536-351     | Condenser Blank Off Plate           | X                          | X       |
| 34             | 552-335-* ① | Filter Door Assembly                | X                          | X       |
| 35             | 152-336-* ① | Circuit Breaker Door                | X                          | X       |
| 36             | 116-238     | Lower Control Panel Bottom          | X                          | X       |
| 37             | 132-166     | Pull Disconnect Door Inner          |                            | X       |
| 37             | 132-165     | Circuit Breaker Door Inner          | X                          |         |
| 38             | 113-281     | Left Filter Bracket                 | X                          | X       |
| 39             | 552-333-* ① | Blower Door Assembly                | X                          | X       |

*Continued on Page 5*

- ① Exterior cabinet parts are manufactured with various color options. To insure that you receive the proper color, you must include the complete models and serial number of the unit for which parts are being ordered.

**This Table references Exploded View on Page 1**

# CABINET COMPONENTS

| Drawing No.                  | Part No.    | Description                    |                            |         |
|------------------------------|-------------|--------------------------------|----------------------------|---------|
|                              |             |                                | QH482DA, DB<br>QH602DA, DB | QH482DC |
| <i>Continued from Page 4</i> |             |                                |                            |         |
| 40                           | 113-286     | Right Filter Bracket           | X                          | X       |
| 41                           | 140Y277     | Left Evaporator Support        | X                          | X       |
| 42                           | 116-243     | Relay Control Panel            | X                          | X       |
| 43                           | 500-393-* ① | Left Side Assembly             | X                          | X       |
| 44                           | 113-142     | Expansion Valve Mounting Plate | X                          | X       |
| 45                           | 134-165-* ① | Base Trim Extension            | 2                          | 2       |
| 46                           | 112X283     | Center Right Filter Bracket    | X                          | X       |
| 46                           | 112Y283     | Center Left Filter Bracket     | X                          | X       |
| 47                           | See Page 17 | Pull Disconnect Assembly       |                            | X       |
| 47                           | See Page 15 | Circuit Breaker Box Assembly   | X                          |         |
| 48                           | 112-229     | Heatstrip Bracket              | X                          | X       |
| 49                           | 112-234     | Mounting Bracket               | 2                          | 2       |
| 50                           | 135-178-* ① | Side Trim – Upper              | 2                          | 2       |
| 51                           | See page 13 | Thermostat Mounting Plate      | X                          | X       |
| 52                           | 104-1096    | Left Thermostat Support Angle  | X                          | X       |
| 53                           | 103-442     | Thermostat Support Offset      | X                          | X       |
| 54                           | 104-1101    | Front Filter Angle             | X                          | X       |
| 55                           | 104-1096    | Right Thermostat Support Angle | X                          | X       |
| 56                           | 102-434     | Sleeve Offset                  | X                          | X       |
| 57                           | 117-237     | Lower Control Panel Top        | X                          | X       |
| 58                           | 534-190     | Evaporator Coil Shield – Left  | X                          | X       |
| 59                           | 103-443     | Door Latch Offset              | X                          | X       |
| 60                           | 140-282     | Transformer Support            |                            | X       |

- ① Exterior cabinet parts are manufactured with various color options. To insure that you receive the proper color, you must include the complete models and serial number of the unit for which parts are being ordered.

This Table references Exploded View on Page 1

**This page has been left blank intentionally.**

# FUNCTIONAL COMPONENTS

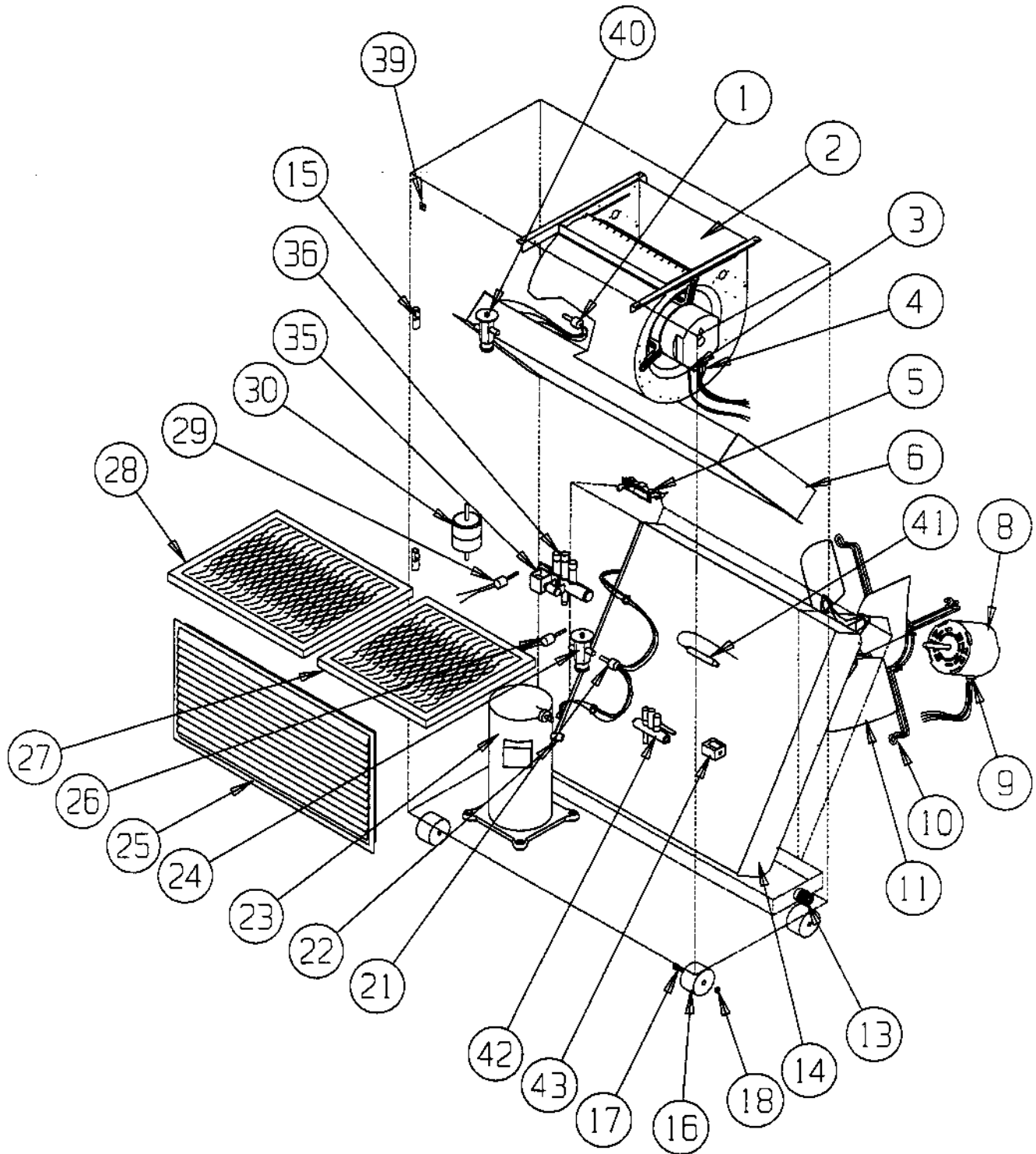

SEXP-376

This Exploded View is referenced in Tables on pages 8, 9 & 10



# FUNCTIONAL COMPONENTS

| Drawing |             |                                 | QH242DA | QH242DB | QH242DC | QH302DA | QH302DB | QH302DC | QH362DA | QH362DB | QH362DC | QH422DA | QH422DB | QH422DC |
|---------|-------------|---------------------------------|---------|---------|---------|---------|---------|---------|---------|---------|---------|---------|---------|---------|
| No.     | Part No.    | Description                     |         |         |         |         |         |         |         |         |         |         |         |         |
| 1       | 5625-015    | Distributor Cooling             | X       | X       | X       | X       | X       | X       |         |         |         |         |         |         |
| 1       | 5625-020    | Distributor Cooling             |         |         |         |         |         |         | X       | X       | X       | X       | X       | X       |
| 2       | 900-225-001 | Blower Assembly                 | X       | X       | X       |         |         |         |         |         |         |         |         |         |
| 2       | 900-225-002 | Blower Assembly                 |         |         |         | X       | X       | X       |         |         |         |         |         |         |
| 2       | 900-225-004 | Blower Assembly                 |         |         |         |         |         |         | X       | X       | X       | X       | X       | X       |
| 3       | 3000-1145   | Wire Harness High Voltage       |         |         | X       |         |         | X       |         |         | X       |         |         | X       |
| 3       | 3000-1046   | Wire Harness High Voltage       | X       | X       |         | X       | X       |         | X       | X       |         | X       | X       |         |
| 4       | 3000-1042   | Wire Harness Low Voltage        | X       | X       | X       | X       | X       | X       | X       | X       | X       | X       | X       | X       |
| 5       | 1171-049    | Keylatch/Circuit Breaker Door   | X       | X       | X       | X       | X       | X       | X       | X       |         |         |         |         |
| 6       | 917-0039    | Evaporator Coil Assembly        | X       | X       | X       | X       | X       | X       |         |         |         |         |         |         |
| 6       | 917-0040    | Evaporator Coil Assembly        |         |         |         |         |         |         | X       | X       | X       | X       | X       | X       |
| 8       | 8103-038    | Motor                           |         |         | X       |         |         | X       |         |         | X       |         |         | X       |
| 8       | 8103-037    | Motor                           | X       | X       |         | X       | X       |         | X       | X       |         | X       | X       |         |
| 9       | 3000-1141   | Wire Harness                    | X       | X       | X       | X       | X       | X       | X       | X       | X       | X       | X       | X       |
| 10      | 8200-001    | Motor Mount                     | X       | X       | X       | X       | X       | X       | X       | X       | X       | X       | X       | X       |
| 11      | 5151-050    | Fan Blade                       | X       | X       | X       | X       | X       | X       | X       | X       | X       | X       | X       | X       |
| 13      | 6094-003    | Drain Fitting                   | 1       | 1       | 1       | 1       | 1       | 1       | 1       | 1       | 1       | 1       | 1       | 1       |
| 14      | 5051-095    | Condenser Coil                  | X       | X       | X       | X       | X       | X       |         |         |         |         |         |         |
| 14      | 5051-096    | Condenser Coil                  |         |         |         |         |         |         | X       | X       | X       | X       | X       | X       |
| 15      | 5400-005    | Hinge                           | 2       | 2       | 2       | 2       | 2       | 2       | 2       | 2       | 2       | 2       | 2       | 2       |
| 16      | 1171-035    | Wheel                           | 4       | 4       | 4       | 4       | 4       | 4       | 4       | 4       | 4       | 4       | 4       | 4       |
| 17      | 1012-129    | Bolt - Shoulder                 | 4       | 4       | 4       | 4       | 4       | 4       | 4       | 4       | 4       | 4       | 4       | 4       |
| 18      | 1012-224    | Nut - Locking                   | 4       | 4       | 4       | 4       | 4       | 4       | 4       | 4       | 4       | 4       | 4       | 4       |
| 21      | 5625-008    | Distributor - Heating           | X       | X       | X       | X       | X       | X       |         |         |         |         |         |         |
| 21      | 5625-010    | Distributor - Heating           |         |         |         |         |         |         | X       | X       | X       | X       | X       | X       |
| 22      | 910-1257    | Defrost Sensor                  | X       | X       | X       | X       | X       | X       | X       | X       | X       | X       | X       | X       |
| 23      | 8000-171    | Compressor                      | X       |         |         |         |         |         |         |         |         |         |         |         |
| 23      | 8000-201    | Compressor                      |         | X       |         |         |         |         |         |         |         |         |         |         |
| 23      | 8000-202    | Compressor                      |         |         | X       |         |         |         |         |         |         |         |         |         |
| 23      | 8000-172    | Compressor                      |         |         |         | X       |         |         |         |         |         |         |         |         |
| 23      | 8000-203    | Compressor                      |         |         |         |         | X       |         |         |         |         |         |         |         |
| 23      | 8000-204    | Compressor                      |         |         |         |         |         | X       |         |         |         |         |         |         |
| 23      | 8000-175    | Compressor                      |         |         |         |         |         |         | X       |         |         |         |         |         |
| 23      | 8000-163    | Compressor                      |         |         |         |         |         |         |         | X       |         |         |         |         |
| 23      | 8000-164    | Compressor                      |         |         |         |         |         |         |         |         | X       |         |         |         |
| 23      | 8000-177    | Compressor                      |         |         |         |         |         |         |         |         |         | X       |         |         |
| 23      | 8000-205    | Compressor                      |         |         |         |         |         |         |         |         |         |         | X       |         |
| 23      | 8000-206    | Compressor                      |         |         |         |         |         |         |         |         |         |         |         | X       |
| 24      | 5651-137    | TXV Heating                     | X       | X       | X       |         |         |         |         |         |         |         |         |         |
| 24      | 5651-138    | TXV Heating                     |         |         |         | X       | X       | X       |         |         |         |         |         |         |
| 24      | 5651-102    | TXV Heating                     |         |         |         |         |         |         | X       | X       | X       | X       | X       | X       |
| 25      | 7051-034    | Return Air Grille               | X       | X       | X       | X       | X       | X       | X       | X       | X       | X       | X       | X       |
| 26      | 8406-055    | High Pressure Control           | X       | X       | X       | X       | X       | X       | X       | X       | X       | X       | X       | X       |
| 27      | 7004-009    | Air Filter                      | X       | X       | X       | X       | X       | X       | X       | X       | X       | X       | X       | X       |
| 27      | 7004-032    | Filter 2" Fiberglass (Optional) | X       | X       | X       | X       | X       | X       | X       | X       | X       | X       | X       | X       |
| 27      | 7004-034    | Filter 2" Pleated (Optional)    | X       | X       | X       | X       | X       | X       | X       | X       | X       | X       | X       | X       |
| 28      | 7004-010    | Air Filter                      | X       | X       | X       | X       | X       | X       | X       | X       | X       | X       | X       | X       |
| 28      | 7004-033    | Filter 2" Fiberglass (Optional) | X       | X       | X       | X       | X       | X       | X       | X       | X       | X       | X       | X       |
| 28      | 7004-035    | Filter 2" Pleated (Optional)    | X       | X       | X       | X       | X       | X       | X       | X       | X       | X       | X       | X       |

Continued on Page 7

This Table references Exploded View on Page 7

# FUNCTIONAL COMPONENTS

| Drawing No. | Part No.  | Description              | QH242DA                      | QH242DB | QH242DC | QH302DA | QH302DB | QH302DC | QH362DA | QH362DB | QH362DC | QH422DA | QH422DB | QH422DC |
|-------------|-----------|--------------------------|------------------------------|---------|---------|---------|---------|---------|---------|---------|---------|---------|---------|---------|
|             |           |                          | <i>Continued from page 8</i> |         |         |         |         |         |         |         |         |         |         |         |
| 29          | 8406-061  | Low Pressure Control     | X                            | X       | X       | X       | X       | X       | X       | X       | X       | X       | X       | X       |
| 30          | 5201-009  | Filter / Drier           | X                            | X       | X       | X       | X       | X       | X       | X       | X       | X       | X       | X       |
| 35          | 5650-020  | Reversing Valve          | X                            | X       | X       |         |         |         |         |         |         |         |         |         |
| 35          | 5650-021  | Reversing Valve          |                              |         |         | X       | X       | X       |         |         |         |         |         |         |
| 35          | 5650-025  | Reversing Valve          |                              |         |         |         |         |         | X       | X       | X       | X       | X       | X       |
| 36          | 5650-022  | Solenoid Coil            | X                            | X       | X       | X       | X       | X       | X       | X       | X       | X       | X       | X       |
| 39          | 1012-315  | "U" Clip Fastener        | 10                           | 10      | 10      | 10      | 10      | 10      | 10      | 10      | 10      | 10      | 10      | 10      |
| 40          | 5651-137  | TXV Cooling              | X                            | X       | X       |         |         |         |         |         |         |         |         |         |
| 40          | 5651-138  | TXV Cooling              |                              |         |         | X       | X       | X       |         |         |         |         |         |         |
| 40          | 5651-102  | TXV Cooling              |                              |         |         |         |         |         | X       | X       | X       | X       | X       | X       |
| 42          | 5650-026  | Three Way Valve          | X                            | X       | X       | X       | X       | X       | X       | X       | X       | X       | X       | X       |
| 43          | 5650-027  | Three Way Valve Solinoid | X                            | X       | X       | X       | X       | X       | X       | X       | X       | X       | X       | X       |
| NS          | 1804-0108 | Low Ambient Control      | X                            | X       | X       | X       | X       | X       | X       | X       | X       | X       | X       | X       |

NS = Not Shown

| Drawing No. | Part No. | Description    | QH242DA | QH242DB  | QH242DC        | QH302DA | QH302DB | QH302DC | QH362DA | QH362DB | QH362DC | QH422DA | QH422DB | QH422DC |
|-------------|----------|----------------|---------|----------|----------------|---------|---------|---------|---------|---------|---------|---------|---------|---------|
|             |          |                | NS      | 4100-107 | Wiring Diagram | X       |         |         | X       |         |         | X       |         |         |
| NS          | 4100-209 | Wiring Diagram |         | X        |                |         | X       |         |         | X       |         |         | X       |         |
| NS          | 4100-309 | Wiring Diagram |         |          | X              |         |         | X       |         |         | X       |         |         | X       |

NS = Not Shown

These Tables reference Exploded View on Page 7

# FUNCTIONAL COMPONENTS

| Drawing |             |                                 | QH482DA | QH482DB | QH482DC |
|---------|-------------|---------------------------------|---------|---------|---------|
| No.     | Part No.    | Description                     |         |         |         |
| 1       | 5625-022    | Cooling Distributor             | X       | X       | X       |
| 2       | 900-225-005 | Blower Assembly                 | X       | X       | X       |
| 3       | 3000-1145   | Wire Harness High Voltage       |         |         | X       |
| 3       | 3000-1046   | Wire Harness High Voltage       | X       | X       |         |
| 4       | 3000-1042   | Wire Harness Low Voltage        | X       | X       | X       |
| 5       | 1171-049    | Keylatch/Circuit Breaker Door   | X       | X       | X       |
| 6       | 917-0041    | Evaporator Coil                 | X       | X       | X       |
| 8       | 8103-038    | Motor                           |         |         | X       |
| 8       | 8103-021    | Motor                           | X       | X       |         |
| 9       | 3000-1141   | Wire Harness                    | X       | X       | X       |
| 10      | 8200-001    | Motor Mount                     | X       | X       | X       |
| 11      | 5151-050    | Fan Blade                       | X       | X       | X       |
| 13      | 6094-003    | Drain Fitting                   | 2       | 2       | 2       |
| 14      | 5051-104    | Condenser Coil                  | X       | X       | X       |
| 15      | 5400-005    | Hinge                           | 2       | 2       | 2       |
| 16      | 1171-035    | Wheel                           | 4       | 4       | 4       |
| 17      | 1012-129    | Bolt - Shoulder                 | 4       | 4       | 4       |
| 18      | 1012-224    | Nut - Locking                   | 4       | 4       | 4       |
| 21      | 5625-007    | Distributor - Heating           | X       | X       | X       |
| 22      | 910-1257    | Defrost Sensor                  | X       | X       | X       |
| 23      | 8000-150    | Compressor                      | X       |         |         |
| 23      | 8000-162    | Compressor                      |         | X       |         |
| 23      | 8000-248    | Compressor                      |         |         | X       |
| 24      | 5651-103    | TXV Heating                     | X       | X       | X       |
| 25      | 7051-039    | Return Air Grille               | X       | X       | X       |
| 26      | 8406-055    | High Pressure Control           | X       | X       | X       |
| 27      | 7004-009    | Air Filter                      | X       | X       | X       |
| 27      | 7004-032    | Filter 2" Fiberglass (Optional) | X       | X       | X       |
| 27      | 7004-034    | Filter 2" Pleated (Optional)    | X       | X       | X       |
| 28      | 7004-011    | Air Filter                      | X       | X       | X       |
| 28      | 7004-036    | Filter 2" Fiberglass (Optional) | X       | X       | X       |
| 28      | 7004-037    | Filter 2" Pleated (Optional)    | X       | X       | X       |
| 29      | 8406-061    | Low Pressure Control            | X       | X       | X       |
| 30      | 5201-009    | Filter / Drier                  | X       | X       | X       |
| 35      | 5650-025    | Reversing Valve                 | X       | X       | X       |
| 36      | 5650-022    | Solenoid Coil                   | X       | X       | X       |
| 39      | 1012-315    | "U" Clip Fastener               | 10      | 10      | 10      |
| 40      | 5651-103    | TXV Cooling                     | X       | X       | X       |
| 42      | 5650-026    | Three Way Valve                 | X       | X       | X       |
| 43      | 5650-027    | Three Way Valve Solenoid        | X       | X       | X       |
| 45      | 8408-038    | Freeze Thermostat               | X       | X       | X       |
| NS      | 1804-0108   | Low Ambient Control             | X       | X       | X       |
| NS      | 4100-107    | Wiring Diagram                  | X       |         |         |
| NS      | 4100-209    | Wiring Diagram                  |         | X       |         |
| NS      | 4100-309    | Wiring Diagram                  |         |         | X       |

NS = Not Shown

These Tables reference Exploded View on Page 7

# UPPER CONTROL PANEL COMPONENTS

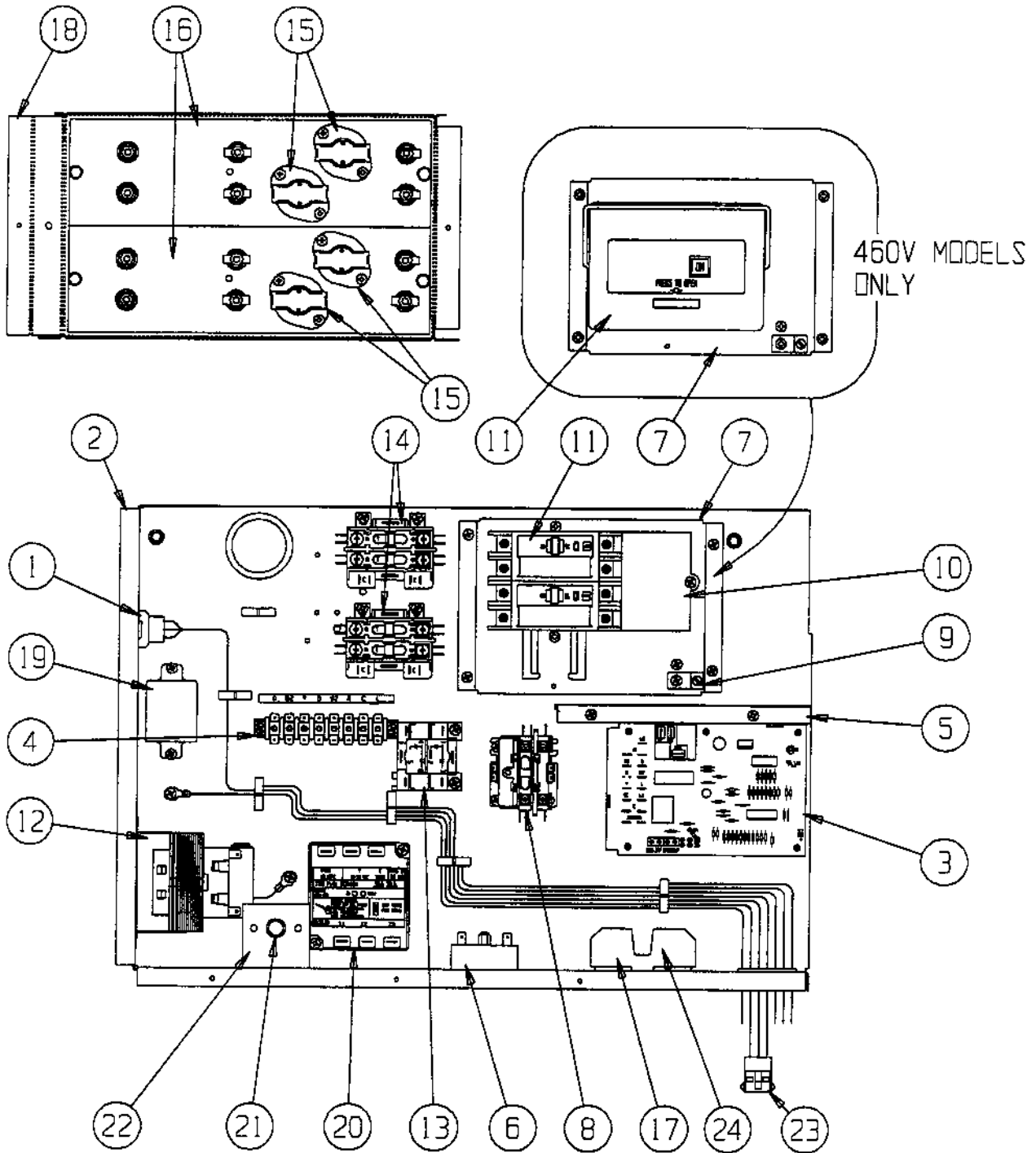

SEXP-373

This Exploded View is referenced in Tables on pages 12,13 & 14

# UPPER CONTROL PANEL COMPONENTS

| Drawing No. | Part No.  | Description                      | QH242DA0Z | QH302DA0Z | QH362DA0Z | QH422DA0Z | QH482DA0Z | QH242DA05 | QH302DA05 | QH362DA05 | QH422DA05 | QH482DA05 | QH242DA10 | QH302DA10 | QH362DA10 | QH422DA10 | QH482DA10 | QH362DA15 | QH422DA15 | QH482DA15 |
|-------------|-----------|----------------------------------|-----------|-----------|-----------|-----------|-----------|-----------|-----------|-----------|-----------|-----------|-----------|-----------|-----------|-----------|-----------|-----------|-----------|-----------|
|             |           |                                  |           |           |           |           |           |           |           |           |           |           |           |           |           |           |           |           |           |           |
| 1           | 3000-1149 | Wire Set PL2                     | X         | X         | X         | X         | X         | X         | X         | X         | X         | X         | X         | X         | X         | X         | X         | X         | X         | X         |
| 2           | 117-241   | Control Panel                    | X         | X         | X         | X         | X         | X         | X         | X         | X         | X         | X         | X         | X         | X         | X         | X         | X         | X         |
| 3           | 8201-069  | Heat Pump Control                | X         | X         | X         | X         | X         | X         | X         | X         | X         | X         | X         | X         | X         | X         | X         | X         | X         | X         |
| 4           | 8607-022  | Terminal Block                   | X         | X         | X         | X         | X         | X         | X         | X         | X         | X         | X         | X         | X         | X         | X         | X         | X         | X         |
| 5           | 117-242   | Box Partition                    | X         | X         | X         | X         | X         | X         | X         | X         | X         | X         | X         | X         | X         | X         | X         | X         | X         | X         |
| 6           | 8201-078  | Low Pressure TDR                 | X         | X         | X         | X         | X         | X         | X         | X         | X         | X         | X         | X         | X         | X         | X         | X         | X         | X         |
| 7           | 126-267   | Circuit Breaker Base             | X         | X         | X         | X         | X         | X         | X         | X         | X         | X         | X         | X         | X         | X         | X         | X         | X         | X         |
| 8           | 8401-007  | Contactor                        | X         | X         | X         |           |           | X         |           | X         |           |           | X         |           | X         |           |           | X         |           |           |
| 8           | 8401-016  | Contactor                        |           |           |           | X         |           |           |           |           | X         |           |           |           |           |           | X         |           |           |           |
| 9           | 8611-006  | Ground Lug                       | X         | X         | X         | X         | X         | X         | X         | X         | X         | X         | X         | X         | X         | X         | X         | X         | X         | X         |
| 10          | 8615-047  | Jumper Bar Base                  |           |           |           |           |           |           |           |           | X         |           | X         |           | X         |           | X         |           | X         |           |
| 11          | 8615-036  | Circuit Breaker 2 Pole 25A Ckt A |           | X         |           |           |           |           |           |           |           | X         |           |           |           |           |           |           |           |           |
| 11          | 8615-037  | Circuit Breaker 2 Pole 30A Ckt A | X         |           |           |           |           |           |           |           |           |           | X         |           |           |           |           |           |           |           |
| 11          | 8615-055  | Circuit Breaker 2 Pole 40A Ckt A |           |           |           |           |           |           |           |           |           |           |           | X         |           |           |           | X         |           |           |
| 11          | 8615-039  | Circuit Breaker 2 Pole 45A Ckt A |           |           | X         |           |           |           |           |           |           | X         |           |           |           |           |           |           |           |           |
| 11          | 8615-040  | Circuit Breaker 2 Pole 50A Ckt A |           |           |           | X         |           | X         |           |           |           | X         |           |           |           |           | X         |           |           | X         |
| 11          | 8615-040  | Circuit Breaker 2 Pole 50A Ckt B |           |           |           |           |           |           |           |           |           |           | X         |           | X         |           | X         |           | X         | X         |
| 11          | 8615-041  | Circuit Breaker 2 Pole 60A Ckt A |           |           |           |           |           |           |           | X         |           |           |           |           |           |           |           |           |           |           |
| 12          | 8407-035  | Transformer                      | X         | X         | X         | X         | X         | X         | X         | X         | X         | X         | X         | X         | X         | X         | X         | X         | X         | X         |
| 14          | 8401-006  | Contactor 2 Pole 20A             |           |           |           |           |           | X         | X         | X         | X         | X         | X         | X         | X         | X         | X         | 2         | 2         | 2         |
| 15          | 8402-100  | Limits                           |           |           |           |           |           | 1         | 1         | 1         | 2         | 2         | 2         | 2         | 2         | 2         | 2         | 3         | 3         | 3         |
| 16          | 8601-103  | Heat Strip 5 KW                  |           |           |           |           |           | X         | X         | X         |           |           |           |           |           |           |           |           | X         | X         |
| 16          | 8601-104  | Heat Strip 10 KW                 |           |           |           |           |           |           |           |           |           |           | X         | X         |           |           |           |           | X         | X         |
| 18          | 118-191   | Heat Strip Wrapper               |           |           |           |           |           | X         | X         | X         | X         | X         | X         | X         | X         | X         | X         | X         | X         | X         |
| 19          | 8201-048  | Relay                            |           |           |           |           |           | X         | X         | X         | X         | X         | X         | X         | X         | X         | X         | X         | X         | X         |
| 21          | 8611-094  | Indicator Light                  | X         | X         | X         | X         | X         | X         | X         | X         | X         | X         | X         | X         | X         | X         | X         | X         | X         | X         |
| 22          | 112-225   | Bracket                          | X         | X         | X         | X         | X         | X         | X         | X         | X         | X         | X         | X         | X         | X         | X         | X         | X         | X         |
| 23          | 3000-1148 | Wire Set PL3                     | X         | X         | X         | X         | X         | X         | X         | X         | X         | X         | X         | X         | X         | X         | X         | X         | X         | X         |
| NS          | 132-145   | Heat Strip Cover                 |           |           |           |           |           | X         | X         | X         | X         | X         | X         | X         | X         | X         | X         | X         | X         | X         |
| NS          | 4101-100  | Wiring Diagram                   | X         | X         | X         | X         |           |           |           |           |           |           |           |           |           |           |           |           |           |           |
| NS          | 4101-101  | Wiring Diagram                   |           |           |           |           |           | X         | X         |           |           |           |           |           |           |           |           |           |           |           |
| NS          | 4101-102  | Wiring Diagram                   |           |           |           |           |           |           |           |           |           |           | X         | X         | X         |           |           |           |           |           |
| NS          | 4101-103  | Wiring Diagram                   |           |           |           |           |           |           |           |           |           |           |           |           |           |           |           | X         | X         |           |
| NS          | 4101-106  | Wiring Diagram                   |           |           |           |           |           |           |           |           |           | X         |           |           |           |           |           |           |           |           |

NS = Not Shown

This Table references Exploded View on Page 11

# UPPER CONTROL PANEL COMPONENTS

| Drawing No. | Part No.  | Description                | QH242DB0Z | QH302DB0Z | QH362DB0Z | QH422DB0Z | QH482DB0Z | QH242DB06 | QH302DB06 | QH362DB06 | QH422DB06 | QH482DB06 | QH242DB09 | QH302DB09 | QH362DB09 | QH422DB09 | QH482DB09 | QH302DB12 | QH362DB15 | QH422DB15 | QH482DB15 |
|-------------|-----------|----------------------------|-----------|-----------|-----------|-----------|-----------|-----------|-----------|-----------|-----------|-----------|-----------|-----------|-----------|-----------|-----------|-----------|-----------|-----------|-----------|
| 1           | 3000-1149 | Wire Set PL2               | X         | X         | X         | X         | X         | X         | X         | X         | X         | X         | X         | X         | X         | X         | X         | X         | X         | X         | X         |
| 2           | 117-241   | Control Panel              | X         | X         | X         | X         | X         | X         | X         | X         | X         | X         | X         | X         | X         | X         | X         | X         | X         | X         | X         |
| 3           | 8201-069  | Heat Pump Control          | X         | X         | X         | X         | X         | X         | X         | X         | X         | X         | X         | X         | X         | X         | X         | X         | X         | X         | X         |
| 4           | 8607-022  | Terminal Block             | X         | X         | X         | X         | X         | X         | X         | X         | X         | X         | X         | X         | X         | X         | X         | X         | X         | X         | X         |
| 5           | 117-242   | Box Partition              | X         | X         | X         | X         | X         | X         | X         | X         | X         | X         | X         | X         | X         | X         | X         | X         | X         | X         | X         |
| 6           | 8201-078  | Low Pressure TDR           | X         | X         | X         | X         | X         | X         | X         | X         | X         | X         | X         | X         | X         | X         | X         | X         | X         | X         | X         |
| 7           | 126-267   | Circuit Breaker Base       | X         | X         | X         | X         | X         | X         | X         | X         | X         | X         | X         | X         | X         | X         | X         | X         | X         | X         | X         |
| 8           | 8401-002  | Contactora                 | X         | X         | X         | X         | X         | X         | X         | X         | X         | X         | X         | X         | X         | X         | X         | X         | X         | X         | X         |
| 9           | 8611-006  | Lug                        | X         | X         | X         | X         | X         | X         | X         | X         | X         | X         | X         | X         | X         | X         | X         | X         | X         | X         | X         |
| 11          | 8615-054  | Circuit Breaker 3 Pole 20A | X         |           |           |           |           |           |           |           |           |           |           |           |           |           |           |           |           |           |           |
| 11          | 8615-051  | Circuit Breaker 3 Pole 25A |           | X         |           |           |           |           |           |           |           |           |           |           |           |           |           |           |           |           |           |
| 11          | 8615-052  | Circuit Breaker 3 Pole 30A |           |           | X         |           |           |           |           |           |           |           |           |           |           |           |           |           |           |           |           |
| 11          | 8615-042  | Circuit Breaker 3 Pole 35A |           |           |           | X         | X         |           |           |           |           |           |           |           |           |           |           |           |           |           |           |
| 11          | 8615-043  | Circuit Breaker 3 Pole 40A |           |           |           |           |           | X         |           |           |           |           |           |           |           |           |           |           |           |           |           |
| 11          | 8615-044  | Circuit Breaker 3 Pole 45A |           |           |           |           |           |           |           | X         |           |           | X         |           |           |           |           |           |           |           |           |
| 11          | 8615-045  | Circuit Breaker 3 Pole 50A |           |           |           |           |           |           |           |           | X         |           |           | X         |           |           |           |           |           |           |           |
| 11          | 8615-046  | Circuit Breaker 3 Pole 60A |           |           |           |           |           |           |           |           |           |           |           |           | X         |           | X         |           |           | X         |           |
| 12          | 8407-035  | Transformer                | X         | X         | X         | X         | X         | X         | X         | X         | X         | X         | X         | X         | X         | X         | X         | X         | X         | X         | X         |
| 14          | 8401-006  | Contactora 2 Pole 20A      |           |           |           |           |           | X         | X         | X         | X         | X         | X         | X         | X         | X         | X         | X         | X         | 2         | 2         |
| 15          | 8402-100  | Limits                     |           |           |           |           |           | 2         | 2         | 2         | 2         | 2         | 2         | 2         | 2         | 2         | 2         | 4         | 4         |           |           |
| 16          | 8604-105  | Heat Strip 6 KW            |           |           |           |           |           | X         | X         | X         |           |           |           |           |           |           |           |           |           | 2         | X         |
| 16          | 8604-106  | Heat Strip 9 KW            |           |           |           |           |           |           |           |           |           |           | X         | X         | X         | X         | X         |           |           |           | X         |
| 18          | 116-191   | Heat Strip Wrapper         |           |           |           |           |           | X         | X         | X         | X         | X         | X         | X         | X         | X         | X         | X         | X         | X         | X         |
| 19          | 8201-048  | Relay                      |           |           |           |           |           | X         | X         | X         | X         | X         | X         | X         | X         | X         | X         | X         | X         | X         | X         |
| 20          | 8201-085  | Phase Monitor              | X         | X         | X         | X         | X         | X         | X         | X         | X         | X         | X         | X         | X         | X         | X         | X         | X         | X         | X         |
| 21          | 8611-094  | Indicator Light            | X         | X         | X         | X         | X         | X         | X         | X         | X         | X         | X         | X         | X         | X         | X         | X         | X         | X         | X         |
| 22          | 112-225   | Bracket                    | X         | X         | X         | X         | X         | X         | X         | X         | X         | X         | X         | X         | X         | X         | X         | X         | X         | X         | X         |
| 23          | 3000-1148 | Wire Set PL3               | X         | X         | X         | X         | X         | X         | X         | X         | X         | X         | X         | X         | X         | X         | X         | X         | X         | X         | X         |
| NS          | 132-145   | Heat Strip Cover           |           |           |           |           |           | X         | X         | X         | X         | X         | X         | X         | X         | X         | X         | X         | X         |           | X         |
| NS          | 4101-200  | Wiring Diagram             | X         | X         | X         | X         |           |           |           |           |           |           |           |           |           |           |           |           |           |           |           |
| NS          | 4101-201  | Wiring Diagram             |           |           |           |           |           | X         | X         | X         | X         | X         | X         | X         | X         | X         | X         |           |           |           |           |
| NS          | 4101-202  | Wiring Diagram             |           |           |           |           |           |           |           |           |           |           |           |           |           |           |           |           |           |           | X         |
| NS          | 4101-203  | Wiring Diagram             |           |           |           |           |           |           |           |           |           |           |           |           |           |           |           | X         |           |           |           |

NS = Not Shown

This Table references Exploded View on Page 11

# UPPER CONTROL PANEL COMPONENTS

| Drawing No. | Part No.  | Description                  | QH242DC0Z | QH302DC0Z | QH362DC0Z | QH422DC0Z | QH482DC0Z | QH242DC06 | QH302DC06 | QH362DC06 | QH422DC06 | QH482DC06 | QH242DC09 | QH302DC09 | QH362DC09 | QH422DC09 | QH482DC09 | QH302DC12 | QH362DC15 | QH422DC15 | QH482DC15 |   |
|-------------|-----------|------------------------------|-----------|-----------|-----------|-----------|-----------|-----------|-----------|-----------|-----------|-----------|-----------|-----------|-----------|-----------|-----------|-----------|-----------|-----------|-----------|---|
|             |           |                              |           |           |           |           |           |           |           |           |           |           |           |           |           |           |           |           |           |           |           |   |
| 1           | 3000-1149 | Wire Set PL2                 | X         |           |           |           |           | X         |           |           |           |           | X         |           |           |           |           | X         |           |           |           | X |
| 2           | 117-241   | Control Panel                | X         |           |           |           |           | X         |           |           |           |           | X         |           |           |           |           | X         |           |           |           | X |
| 3           | 8201-069  | Heat Pump Control            | X         |           |           |           |           | X         |           |           |           |           | X         |           |           |           |           | X         |           |           |           | X |
| 4           | 8607-022  | Terminal Block               | X         |           |           |           |           | X         |           |           |           |           | X         |           |           |           |           | X         |           |           |           | X |
| 5           | 117-242   | Box Partition                | X         |           |           |           |           | X         |           |           |           |           | X         |           |           |           |           | X         |           |           |           | X |
| 6           | 8201-078  | Low Pressure Bypass TDR      | X         |           |           |           |           | X         |           |           |           |           | X         |           |           |           |           | X         |           |           |           | X |
| 7           | 126-269   | Pull Disconnect Base         | X         |           |           |           |           | X         |           |           |           |           | X         |           |           |           |           | X         |           |           |           | X |
| 8           | 8401-002  | Contactors                   | X         |           |           |           |           | X         |           |           |           |           | X         |           |           |           |           | X         |           |           |           | X |
| 9           | 8611-006  | Ground Lug                   | X         |           |           |           |           | X         |           |           |           |           | X         |           |           |           |           | X         |           |           |           | X |
| 11          | 8615-053  | Pull Disconnect Base         | X         |           |           |           |           | X         |           |           |           |           | X         |           |           |           |           | X         |           |           |           | X |
| 12          | 8407-035  | Transformer                  | X         |           |           |           |           | X         |           |           |           |           | X         |           |           |           |           | X         |           |           |           | X |
| 13          | 8201-009  | Relay OMR                    | X         |           |           |           |           | X         |           |           |           |           | X         |           |           |           |           | X         |           |           |           | X |
| 14          | 8401-002  | Contactors 3 Pole 25A        |           |           |           |           |           | X         |           |           |           |           | X         |           |           |           |           | X         |           |           |           | 2 |
| 15          | 8402-100  | Limits                       |           |           |           |           |           | 2         |           |           |           |           | 4         |           |           |           |           | 4         |           |           |           | 4 |
| 16          | 8604-107  | Heat Strip 6 KW 480V         |           |           |           |           |           | X         |           |           |           |           |           |           |           |           |           | 2         |           |           |           | X |
| 16          | 8604-108  | Heat Strip 9 KW 480V         |           |           |           |           |           |           |           |           |           |           | X         |           |           |           |           |           |           |           |           | X |
| 17          | 8614-041  | Fuse Holder                  | X         |           |           |           |           | X         |           |           |           |           | X         |           |           |           |           | X         |           |           |           | X |
| 18          | 116-191   | Heat Strip Wrapper           |           |           |           |           |           | X         |           |           |           |           | X         |           |           |           |           | X         |           |           |           | X |
| 19          | 8201-048  | Relay                        |           |           |           |           |           | X         |           |           |           |           | X         |           |           |           |           | X         |           |           |           | X |
| 20          | 8201-085  | Phase Monitor                | X         |           |           |           |           | X         |           |           |           |           | X         |           |           |           |           | X         |           |           |           | X |
| 21          | 8611-094  | Indicator Light              | X         |           |           |           |           | X         |           |           |           |           | X         |           |           |           |           | X         |           |           |           | X |
| 22          | 112-225   | Bracket                      | X         |           |           |           |           | X         |           |           |           |           | X         |           |           |           |           | X         |           |           |           | X |
| 23          | 3000-1148 | Wire Set PL3                 | X         |           |           |           |           | X         |           |           |           |           | X         |           |           |           |           | X         |           |           |           | X |
| NS          | 8407-052  | Transformer Stepdown 1.0 KVA | X         |           |           |           |           | X         |           |           |           |           | X         |           |           |           |           | X         |           |           |           | X |
| NS          | 8407-053  | Transformer Stepdown 1.5 KVA | X         |           |           |           |           | X         |           |           |           |           | X         |           |           |           |           | X         |           |           |           | X |
| NS          | 8614-046  | Fuses Class CC 5A ①          | 2         |           |           |           |           | 2         |           |           |           |           | 2         |           |           |           |           | 2         |           |           |           | 2 |
| NS          | 8614-047  | Fuses Class CC 3.2A ②        | 2         |           |           |           |           | 2         |           |           |           |           | 2         |           |           |           |           | 2         |           |           |           | 2 |
| NS          | 132-145   | Heat Strip Cover             |           |           |           |           |           | X         |           |           |           |           | X         |           |           |           |           | X         |           |           |           | X |
| NS          | 4101-300  | Wiring Diagram               | X         |           |           |           |           |           |           |           |           |           |           |           |           |           |           |           |           |           |           |   |
| NS          | 4101-301  | Wiring Diagram               |           |           |           |           |           | X         |           |           |           |           | X         |           |           |           |           |           |           |           |           |   |
| NS          | 4101-302  | Wiring Diagram               |           |           |           |           |           |           |           |           |           |           |           |           |           |           |           |           |           |           |           | X |
| NS          | 4101-303  | Wiring Diagram               |           |           |           |           |           |           |           |           |           |           |           |           |           |           |           | X         |           |           |           |   |

NS = Not Shown

① 5 Amp fuses used with 1.5 KVA transformer.

② 3.2 Amp fuses used with 1KVA transformer.

This Table references Exploded View on Page 11

# LOWER CONTROL PANEL COMPONENTS

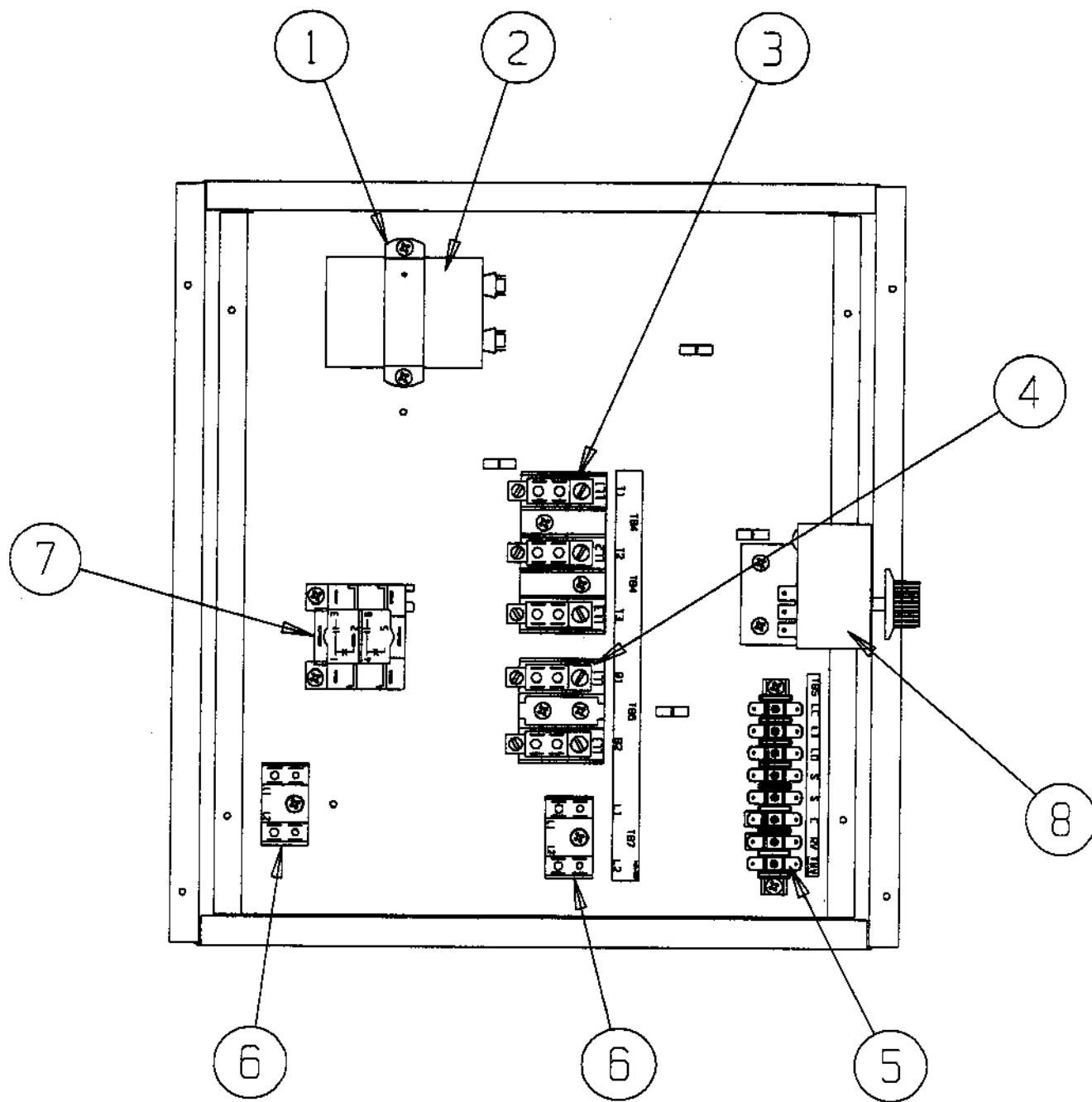

SEXP-374



## LOWER CONTROL PANEL COMPONENTS

| Drawing |          |                                 | QH242DA | QH302DA | QH362DA | QH422DA | QH482DA | QH242DB | QH302DB | QH362DB | QH422DB | QH482DB | QH602DB | QH242DC | QH302DC | QH362DC | QH422DC | QH482DC | QH602DC |
|---------|----------|---------------------------------|---------|---------|---------|---------|---------|---------|---------|---------|---------|---------|---------|---------|---------|---------|---------|---------|---------|
| No.     | Part No. | Description                     |         |         |         |         |         |         |         |         |         |         |         |         |         |         |         |         |         |
| 1       | 8552-008 | Capacitor Strap                 | X       | X       | X       | X       | X       |         |         |         |         |         |         |         |         |         |         |         |         |
| 1       | 8552-003 | Capacitor Strap                 |         |         |         |         |         | X       |         |         |         |         |         |         |         |         | X       |         |         |
| 2       | 8552-002 | Fan Capacitor                   |         |         |         |         |         |         | X       |         |         |         |         |         |         |         | X       |         |         |
| 2       | 8552-050 | Compressor Capacitor            | X       |         |         |         |         |         |         |         |         |         |         |         |         |         |         |         |         |
| 2       | 8552-052 | Compressor Capacitor            |         | X       |         |         |         |         |         |         |         |         |         |         |         |         |         |         |         |
| 2       | 8552-063 | Compressor Capacitor            |         |         | X       |         |         |         |         |         |         |         |         |         |         |         |         |         |         |
| 2       | 8552-062 | Compressor Capacitor            |         |         |         | X       | X       |         |         |         |         |         |         |         |         |         |         |         |         |
| 3       | 8607-014 | Terminal Block 3 Ter            |         |         |         |         |         | X       |         |         |         |         |         |         |         |         | X       |         |         |
| 4       | 8607-013 | Terminal Block 2 Ter            | X       | X       | X       | X       | X       |         |         |         |         |         |         |         |         |         |         |         | X       |
| 5       | 8607-022 | Terminal Block 8 Pos            | X       | X       | X       | X       | X       | X       |         |         |         |         |         |         |         |         |         |         | X       |
| 6       | 8607-017 | Terminal Block 2 Ter            | X       | X       | X       | X       | X       | X       |         |         |         |         |         |         |         |         |         |         | X       |
| 7       | 8201-032 | Low Ambient Bypass Relay (Opt.) | X       | X       | X       | X       | X       |         | X       |         |         |         |         |         |         |         |         |         | X       |
| 8       | 8408-034 | Outdoor Thermostat ①            | X       | X       | X       | X       | X       |         |         |         | X       |         |         |         |         |         |         |         | X       |

① Optional on standard models. Standard on low ampacity models.

## DEHUMIDIFICATION MODULE COMPONENTS

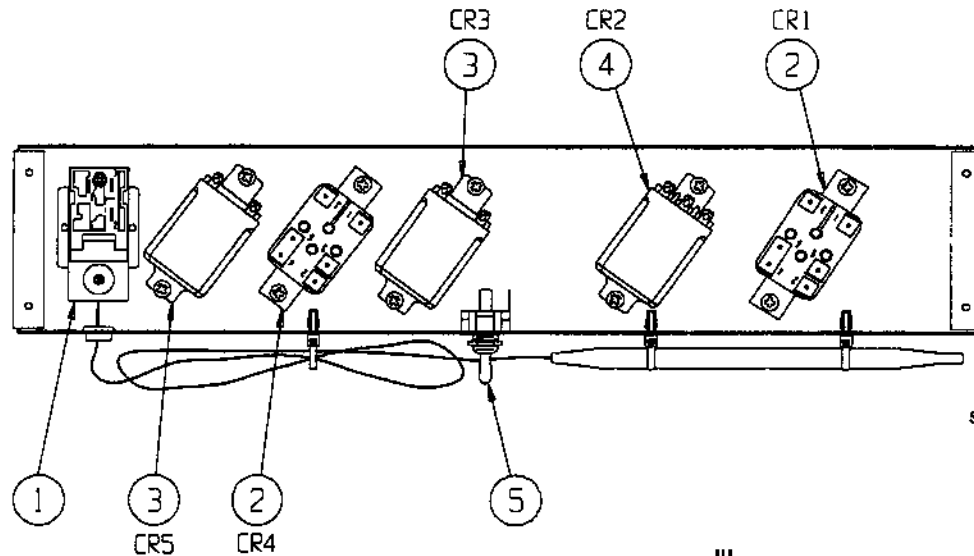

| Drawing |           |                       | Options X, E | Option F |
|---------|-----------|-----------------------|--------------|----------|
| No.     | Part No.  | Description           |              |          |
| 1       | 8408-037  | Return Air Thermostat | X            | X        |
| 2       | 8201-062  | Relay CR1, CR4        | 2            | 2        |
| 3       | 8201-048  | Relay CR3, CR5        | 2            | 2        |
| 4       | 8201-071  | Relay CR2             | 1            | 1        |
| 5       | 8408-020  | Toggle Switch         | X            | X        |
| NS      | 3000-1154 | Wire Harness P2 to P4 | X            |          |
| NS      | 3000-1153 | Wire Harness P2 to P4 |              | X        |

# BLOWER ASSEMBLY COMPONENTS

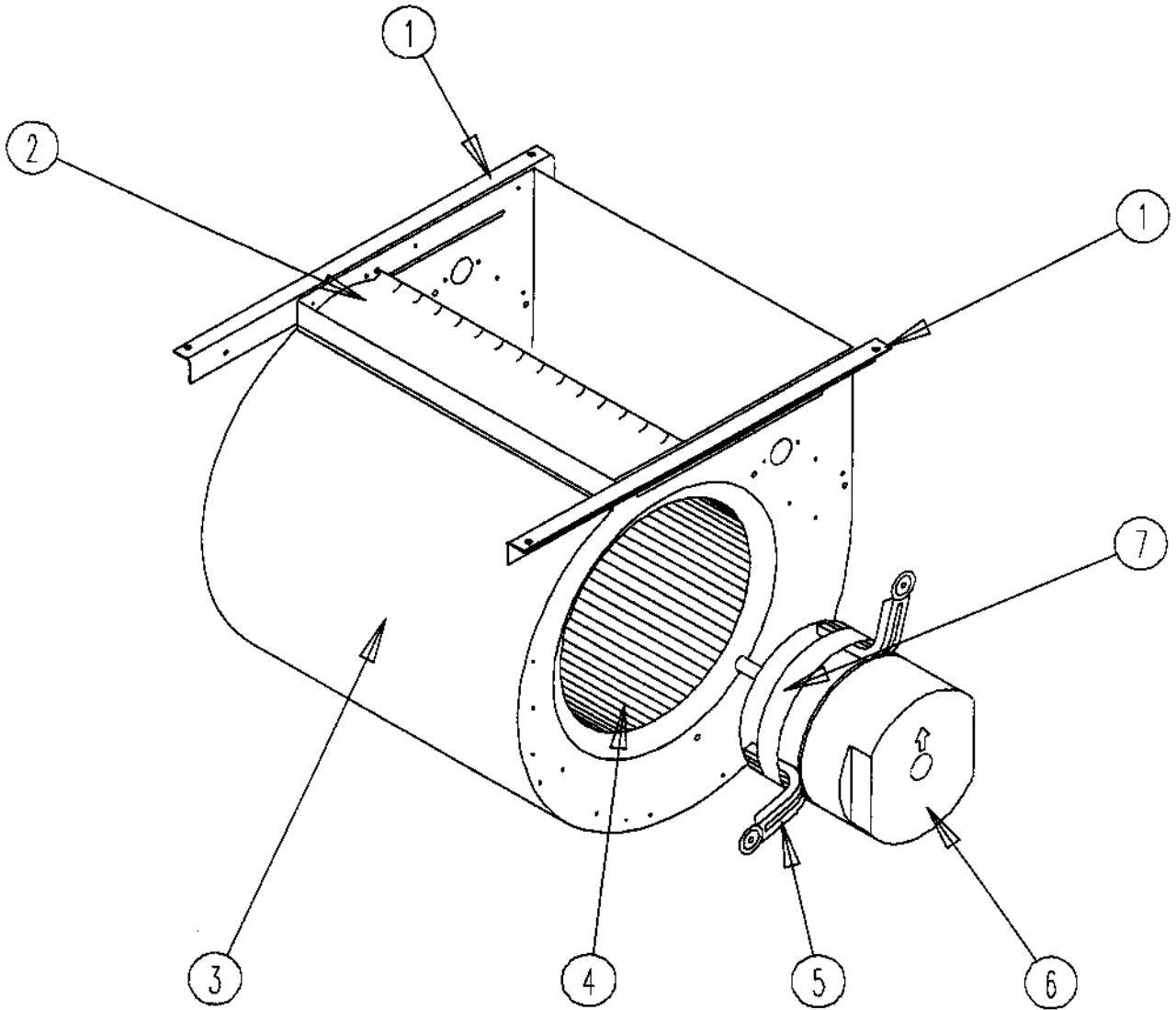

SEXP-245

# BLOWER ASSEMBLY COMPONENTS

| Drawing<br>No. | Part No.       | Description      | 900-225-001 | 900-225-002 | 900-225-004 | 900-225-005 |
|----------------|----------------|------------------|-------------|-------------|-------------|-------------|
| 1              | 104-980        | Blower Angle     | 2           | 2           | 2           | 2           |
| 2              | 144-131        | Diffuser         | X           | X           | X           | X           |
| 3              | 151-110        | Blower Housing   | X           | X           | X           | X           |
| 4              | 5152-061       | Blower Wheel     | X           | X           | X           | X           |
| 5              | 8200-034       | Motor Mount Arm  | 3           | 3           | 3           | 3           |
| 6              | 8106-035-0003  | Motor            | X           |             |             |             |
| 6              | 8106-035-0004  | Motor            |             | X           |             |             |
| 6              | 8106-035-0005A | Motor            |             |             | X           |             |
| 6              | 8106-035-0013  | Motor            |             |             |             | X           |
| 7              | 8200-033       | Motor Mount Band | X           | X           | X           | X           |

# OPTIONAL CLIMATE CONTROLS

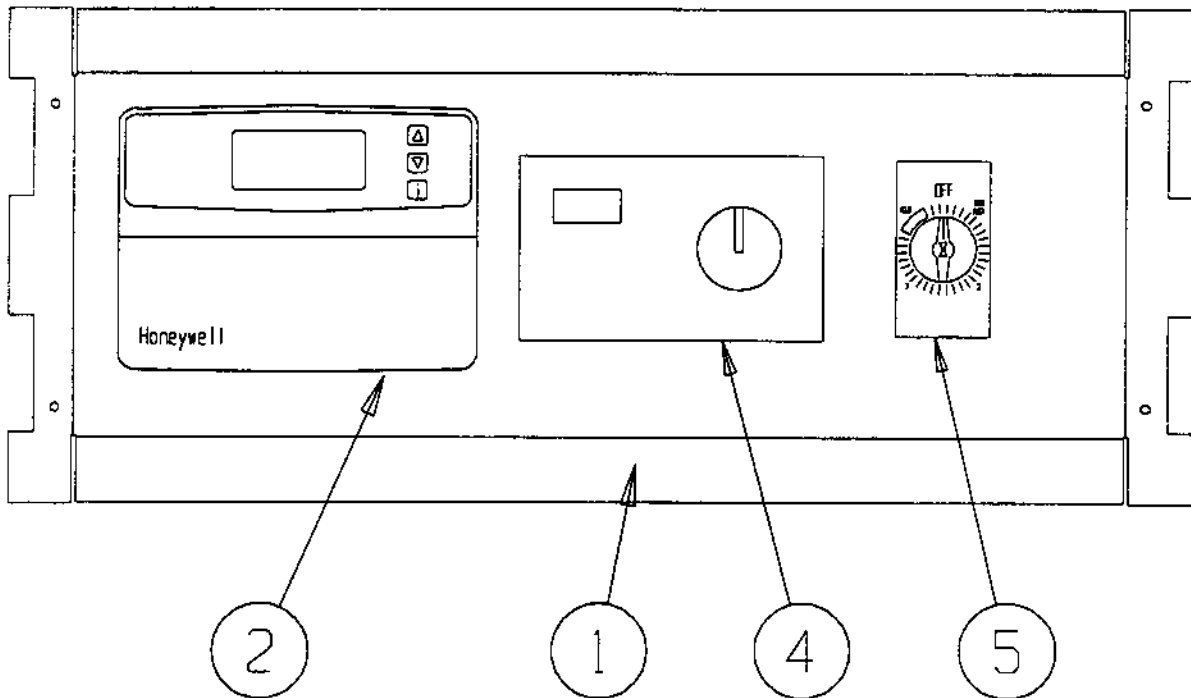
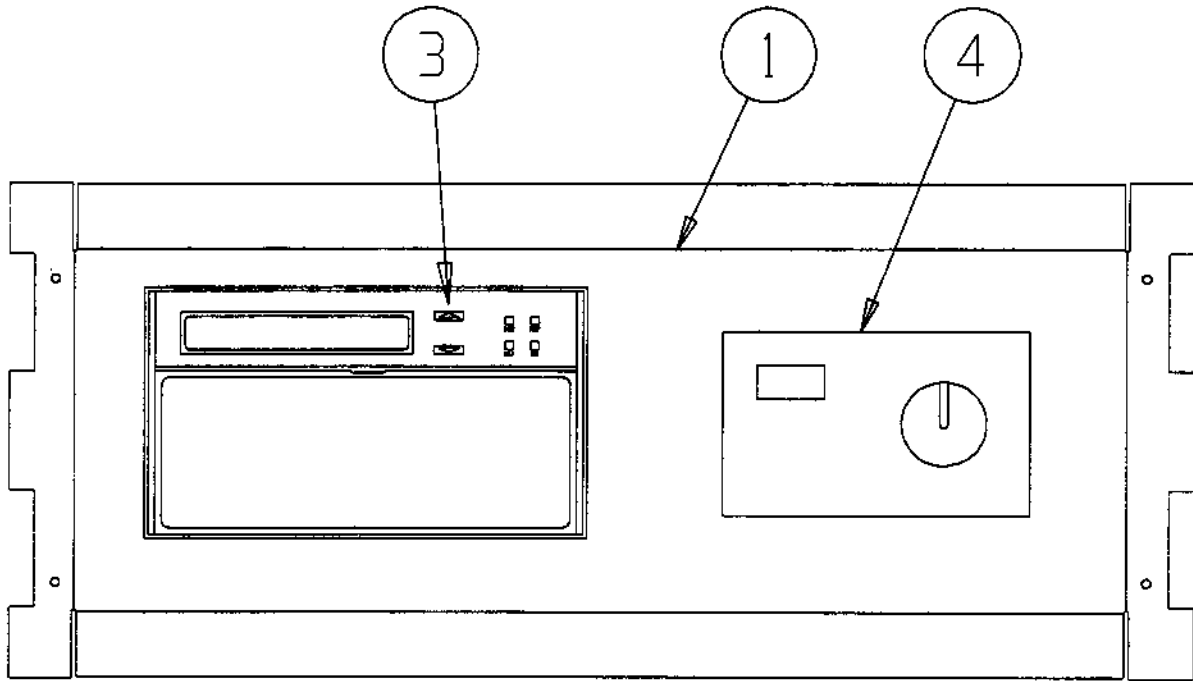

SEXP-371

# OPTIONAL CLIMATE CONTROLS

| Drawing No. | Part No.    | Description   | QH242, QH302<br>QH362, QH422 |          |          | QH482    |          |          |
|-------------|-------------|---|------------------------------|----------|----------|----------|----------|----------|
|             |             |   | Option X                     | Option E | Option F | Option X | Option E | Option F |
| 1           | 127-313-* ① | Thermostat Plate  | X                            |          |          | X        |          |          |
| 1           | 127-314-* ① | Thermostat Plate  |                              | X        |          |          | X        |          |
| 1           | 127-312-* ① | Thermostat Plate  |                              |          | X        |          |          | X        |
| 2           | 8403-042    | Electronic / Non-Programmable / Manual / Auto Change Over |                              |          | X        |          |          | X        |
| 3           | 8403-034    | Electronic / Programmable / Manual / Auto Change Over     |                              | X        |          |          | X        |          |
| 4           | 8403-047    | Humidistat  |                              | X        | X        |          | X        | X        |
| 5           | 8612-015    | Timer   |                              |          | X        |          |          | X        |
| NS          | 3000-1151   | Wire Harness, Low Voltage Terminal Strip to PL2           | X                            |          |          | X        |          |          |
| NS          | 3000-1152   | Wire Harness, Thermostat to PL2                           |                              | X        |          |          | X        |          |
| NS          | 3000-1150   | Wire Harness, Thermostat to PL2                           |                              |          | X        |          |          | X        |
| NS          | 8607-019    | Low Voltage Terminal Strip                                | X                            |          | X        | X        |          | X        |
| NS          | 8607-021    | Low Voltage Terminal Strip * Term.                        | X                            |          |          | X        |          |          |
| NS          | 4102-023    | Wiring Diagram  | X                            |          |          | X        |          |          |
| NS          | 4102-025    | Wiring Diagram  |                              | X        |          |          | X        |          |
| NS          | 4102-024    | Wiring Diagram  |                              |          | X        |          |          | X        |

① Exterior cabinet parts are manufactured with various color options. To insure that you receive the proper color, you must include the complete models and serial number of the unit for which parts are being ordered.

NS Not Shown

## CLIMATE CONTROL OPTION NOMENCLATURE AS SHOWN IN UNIT MODEL NUMBER

QH 362 D A 09 X X X X X

- X - None
- A - Electronic, non-programmable, manual change over
- D - Electronic, programmable, manual/auto change over

# WALL SLEEVE CABINET COMPONENTS

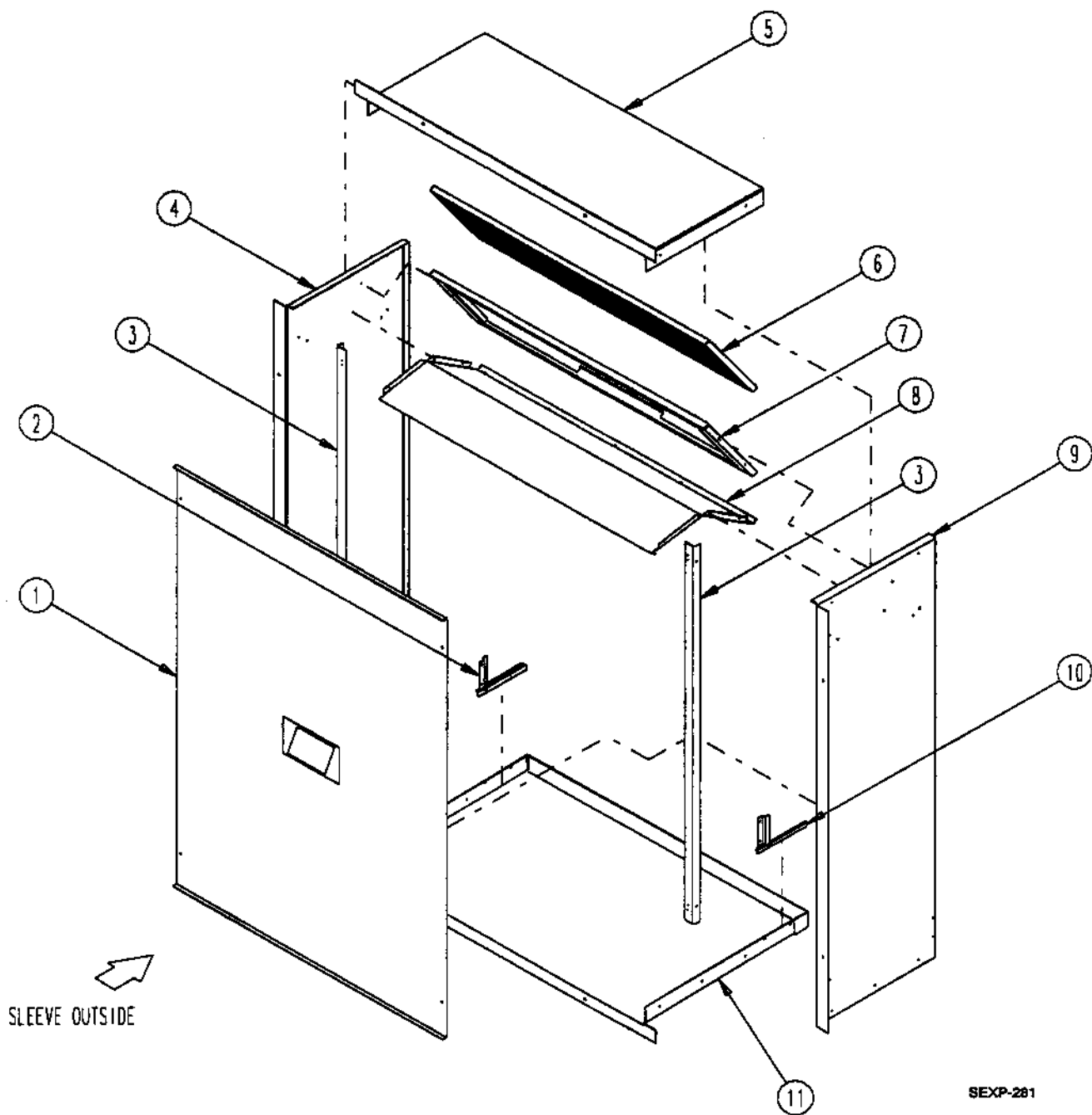

SEXP-281

## WALL SLEEVE CABINET COMPONENTS

| Drawing No. | Part No. | Description           | QWS42 | QWS42-16 | QWS48 | QWS48-16 |
|-------------|----------|-----------------------|-------|----------|-------|----------|
| 1           | 142-056  | Cover                 | X     | X        |       |          |
| 1           | 142-068  | Cover                 |       |          | X     | X        |
| 2           | 136Y361  | Left Side Seal Angle  | X     | X        | X     | X        |
| 3           | 104-988  | Angle                 | 2     | 2        | 2     | 2        |
| 4           | 110Y045  | Left Side             | X     |          | X     |          |
| 4           | 110Y048  | Left Side             |       | X        |       | X        |
| 5           | 110-047  | Top                   | X     |          |       |          |
| 5           | 110-050  | Top                   |       | X        |       |          |
| 5           | 110-056  | Top                   |       |          | X     |          |
| 5           | 110-070  | Top                   |       |          |       | X        |
| 6           | 7003-044 | Mist Eliminator       | X     | X        | X     | X        |
| 7           | 130-120  | Filter Tray           | X     | X        |       |          |
| 7           | 130-128  | Filter Tray           |       |          | X     | X        |
| 8           | 120-305  | Partition             | X     |          |       |          |
| 8           | 120-309  | Partition             |       | X        |       |          |
| 8           | 120-322  | Partition             |       |          | X     |          |
| 8           | 120-348  | Partition             |       |          |       | X        |
| 9           | 110X045  | Right Side            | X     |          | X     |          |
| 9           | 110X048  | Right Side            |       | X        |       | X        |
| 10          | 136X361  | Right Side Seal Angle | X     | X        |       |          |
| 10          | 136-404  | Right Side Seal Angle |       |          | X     | X        |
| 11          | 111-046  | Base                  | X     |          |       |          |
| 11          | 111-049  | Base                  |       | X        |       |          |
| 11          | 111-055  | Base                  |       |          | X     |          |
| 11          | 111-071  | Base                  |       |          |       | X        |