REPLACEMENT PARTS MANUAL

WALL MOUNTED PACKAGE HEAT PUMPS

Model: **SH611**

General Notes

- Revised and/or additional pages may be issued from time to time.
- A complete and current manual consists of pages shown in the following contents section.

Important

- Contact the installing and/or local Bard distributor for all parts requirements. Make sure you have the complete model and serial number available from the unit rating plates.

Contents

<i>Description</i>	<i>Page</i>
Cabinet Components	
♦ Exploded View	1
♦ Usage List	2
Functional Components	
♦ Exploded View	3
♦ Usage List	4
Control Panel	
♦ Layout	5
♦ Usage List	6
Blower Assembly	
♦ Exploded View	7
♦ Usage List	7



CLIMATE CONTROL SOLUTIONS

BARD MANUFACTURING COMPANY
Bryan, Ohio 43506

Since 1914...Moving ahead, just as planned.

Manual: 2110-540A
Supersedes: 2110-540
File: Tab 17
Date: 06-18-02

CABINET COMPONENTS

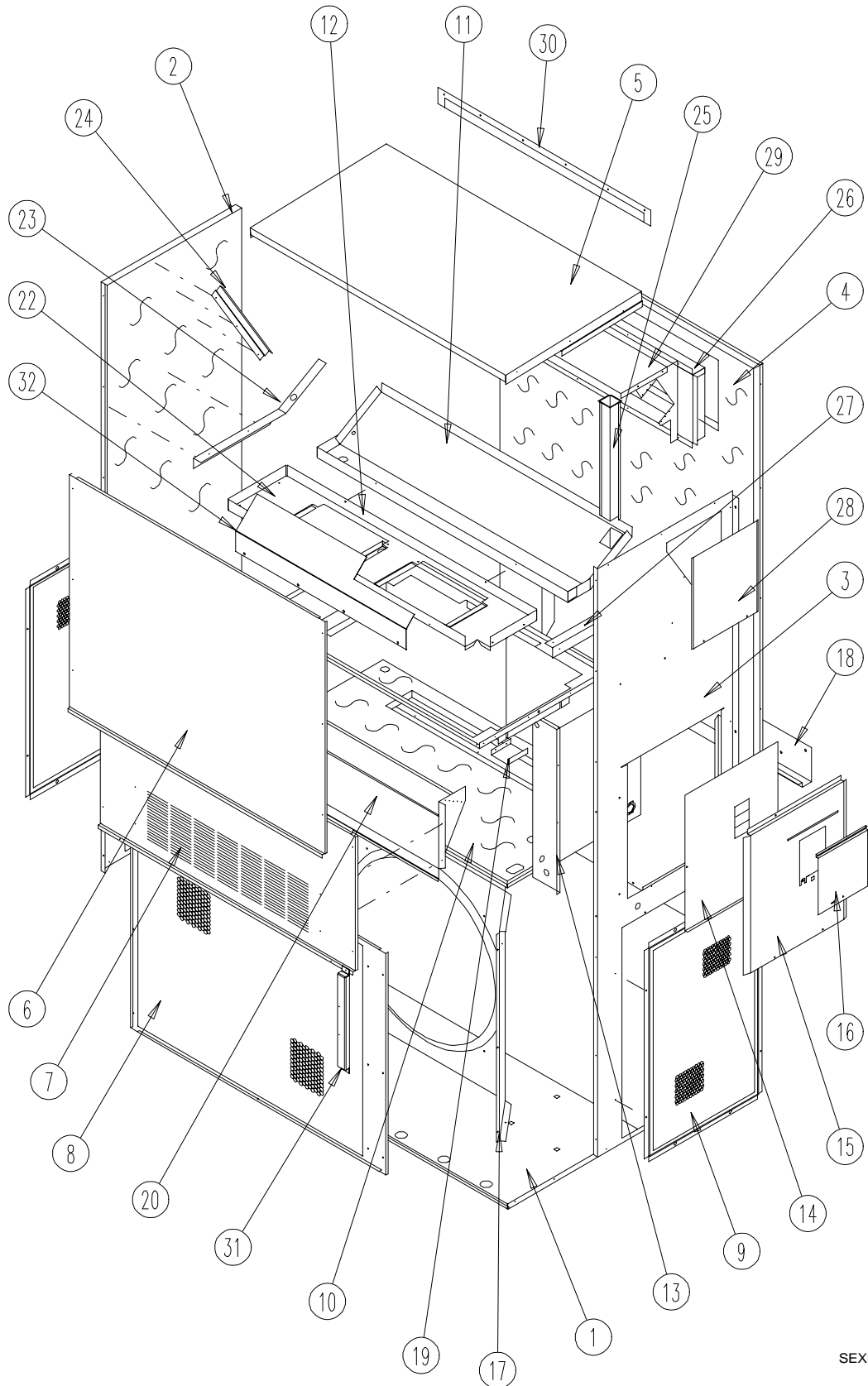

SEXP-305

CABINET COMPONENTS

Dwg No.	Part No.	Description	SH611-A, B	SH611-C
1	S127X214	Lower Base	X	X
2	S500-316-* ①	Left Side	X	X
3	S500-315-* ①	Right Side	X	X
4	S509-126	Back	X	X
5	S506-140 ①	Top	X	X
6	S514-077-* ①	Upper Front	X	X
7	S552-224-* ①	Service Door	X	X
8	118-040-* ①	Condenser Grille	X	X
9	118-041-* ①	Side Grille	2	2
10	S521X258	Condenser Partition	X	X
11	123-102	Drain Pan	X	X
12	121X216	Blower Partition	X	X
13	Control Panel Assembly	See Control Panel Assembly Drawing and Parts List	X	X
14	S133-114	Control Panel Cover (Inner)	X	
14	S133-115	Control Panel Cover (Inner)		X
15	S533-113-* ①	Control Panel Cover (Outer)	X	X
16	S153-218-* ①	Disconnect Access Door	X	X
17	125-029	Fan Shroud	X	X
18	113-140	Bottom Mounting Bracket	X	X
19	137-209	Fill	X	X
20	BFAD-5	Fresh Air Damper Assembly	X	X
22	131X099	Filter Tray	X	X
23	105X877	Left Side Support	X	X
24	147-046-* ①	Left Evaporator Support	X	X
25	135-128	Raceway	2	2
26	111X034	Outlet Airframe Assembly	X	X
27	105X878	Right Side Support	X	X
28	143-042-* ①	Right Side Cover Plate (Outer)	X	X
29	135-129	Heat Shield	X	X
30	113-150-* ①	Top Rain Flashing	X	X

① Exterior cabinet parts are manufactured with various paint color options. To insure that you receive the proper paint color, you must include the complete model and serial number of the unit for which cabinet parts are being ordered.

FUNCTIONAL COMPONENTS

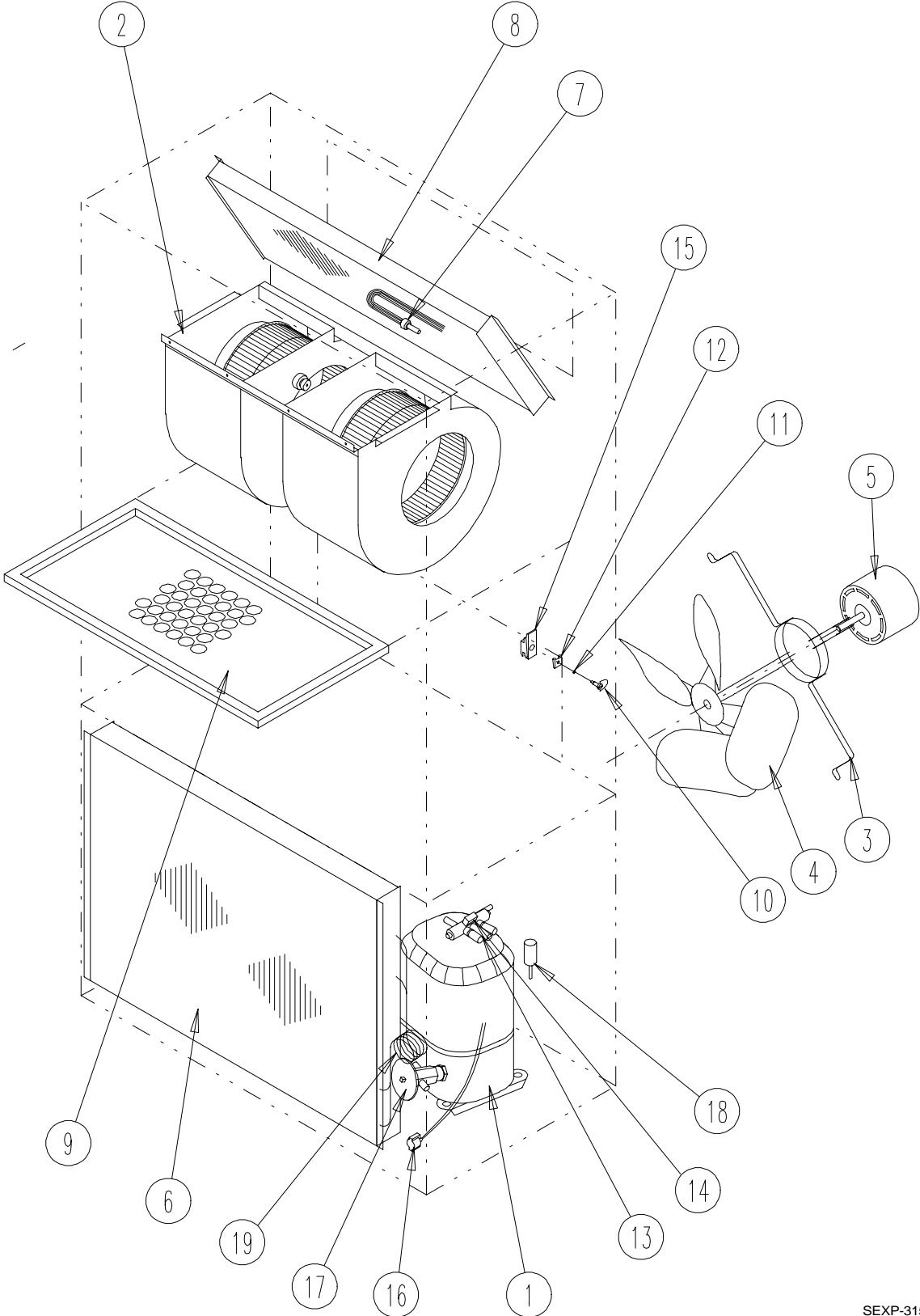

SEXP-315

FUNCTIONAL COMPONENTS

Dwg No.	Part No.	Description	SH611-A	SH611-B	SH611-C
1	8000-153	Compressor	X		
1	8000-154	Compressor		X	
1	8000-155	Compressor			X
2	S900-242	Blower Assembly	X	X	
2	S900-243	Blower Assembly			X
3	8200-004	Fan Motor Mount	X	X	X
4	5151-027	Fan Blade	X	X	X
5	8105-039	Condenser Motor	X	X	
5	8105-030	Condenser Motor			X
6	5051-124	Condenser Coil	X	X	X
7	800-0295	Cooling Distributor Assembly	X	X	X
8	5060-082	Evaporator Coil	X	X	X
9	7004-016	Air Filter 1" Throw-away	X	X	X
9	7003-030	Air Filter 1" Washable	X	X	X
9	7004-027	Air Filter 2" Pleated	X	X	X
10	1171-022	1/4" Turn Fastener	X	X	X
11	1171-024	1/4" Turn Retainer	X	X	X
12	1171-023	1/4" Receptacle	X	X	X
13	5650-025	Reversing Valve	X	X	X
14	5650-022	Reversing Valve Solenoid	X	X	X
16	8408-027	Defrost Sensor	X	X	X
17	5651-105	Expansion Valve	X	X	X
18	1804-0106	High Pressure Switch (Flare) ①	X	X	X
19	800-0291	Heating Distributor Assembly	X	X	X
NS	1804-0107	Low Pressure Switch (Flare) ①	X	X	X
NS	1804-0108	Low Ambient Switch (Flare) ①	X	X	X

NS – Not Shown

① – Optional

CONTROL PANEL

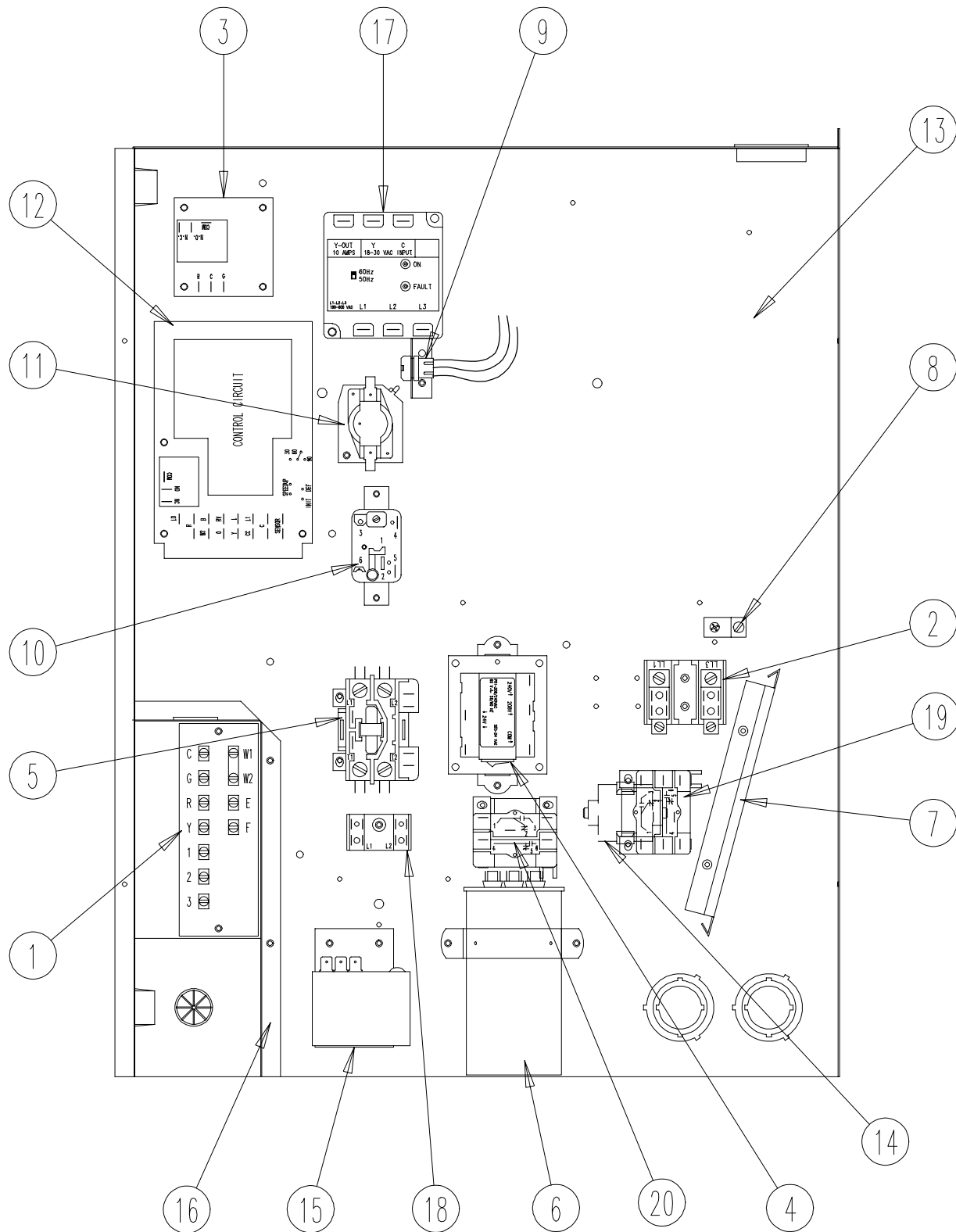

SEXP-311

CONTROL PANEL

Dwg No.	Part No.	Description	SH611-A	SH611-B	SH611-C
1	8607-019	Low Voltage Terminal Strip	X	X	X
2	8607-013	Terminal Block 2 Pole	X		
2	8607-014	Terminal Block 3 Pole		X	X
2	8607-015	Phelon Insulator			X
3	8201-056	Blower Control	X	X	
3	8201-032	Blower Relay			X
4	8407-048	Transformer	X	X	
4	8407-050	Transformer			X
5	8401-027	Compressor Contactor		X	
5	8401-002	Compressor Contactor			X
5	8401-016	Compressor Contactor	X		
6	8552-005	Outdoor Motor Capacitor		X	X
6	8552-058	Compressor Capacitor	X		
7	135-130	Wire Shield	X	X	X
8	8611-006	Ground Terminal	X	X	X
9	3000-977	6 Pin Connector	X	X	X
10	8201-009	Low Ambient Bypass Relay	X	X	X
11	8201-065	Low Pressure Bypass (TDR) ①	X	X	X
12	8201-069	Heat Pump Control Board	X	X	X
13	117X143	Control Panel	X	X	X
15	8408-034	Outdoor Fan Thermostat	X	X	X
16	117X139	Low Voltage Box	X	X	X
17	8201-085	Phase Monitor		X	X
18	8607-017	Terminal Block ①	X	X	X
19	8201-086	Motor Speed Relay			X
20	8201-032	Outdoor Fan Relay			X
NS	4096-125	Wiring Diagram	X		
NS	4096-227	Wiring Diagram		X	
NS	4096-327	Wiring Diagram			X
NS	8615-041	Circuit Breaker 60A 2 Pole (0Z)	X		
NS	8615-044	Circuit Breaker 45A 3 Pole (0Z)		X	
NS	8615-067	Toggle Disconnect			X

NS – Not Shown

① – Optional

BLOWER ASSEMBLY

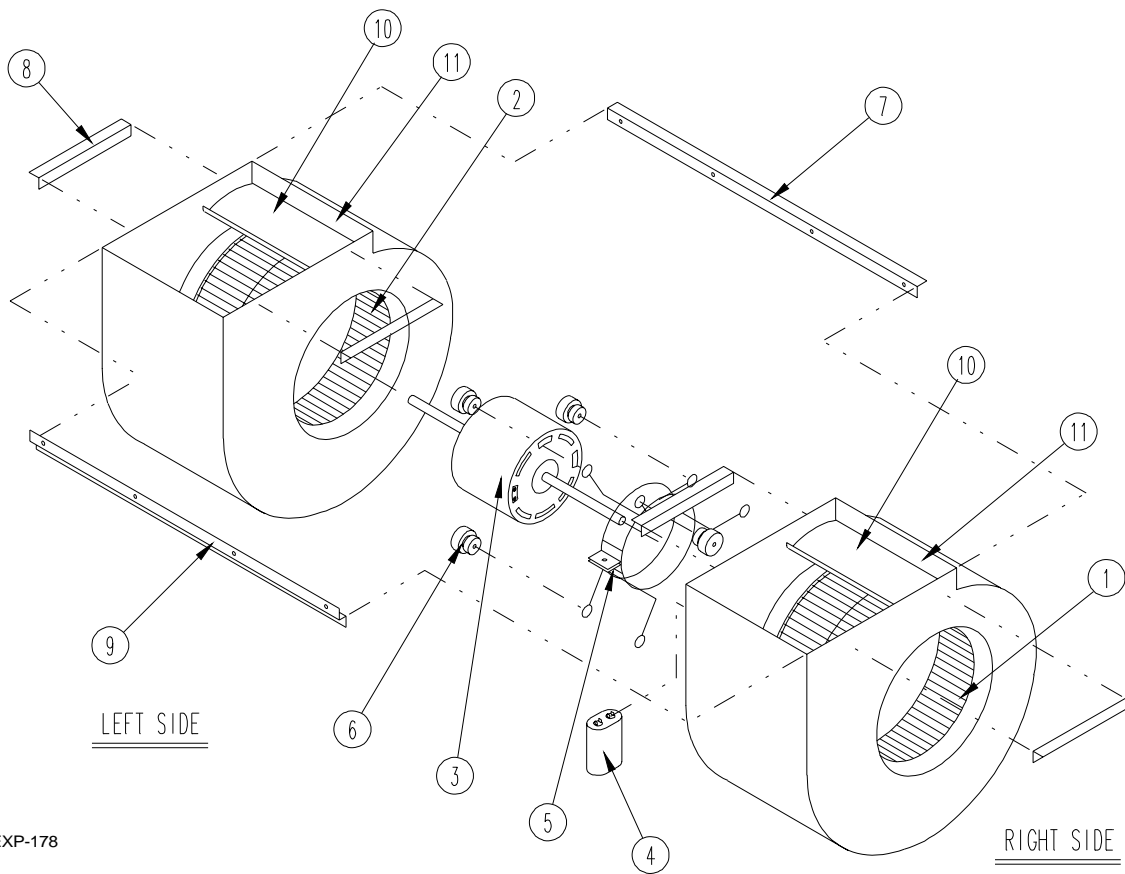

SEXP-178

Dwg. No.	Part No.	Description	900-242	900-243
1	5152-011	10 Inch Wheel (CW)	X	X
2	5152-012	10 Inch Wheel (CCW)	X	X
3	8104-012	Blower Motor (230/208)	X	
3	8104-014	Blower Motor (460)		X
4	8552-005	Capacitor	X	X
5	8200-040	Motor Mount	X	X
6	5451-001	Grommets	6	6
7	105-880	Back Brace	X	X
8	105-881	Side Angle	4	4
9	103-389	Front Brace	X	X
10	151-101	Housing	2	2
11	144-166	Diffuser	2	2