

REPLACEMENT PARTS MANUAL

QTEC SERIES PACKAGED HEAT PUMP Models:

QW242D QW302D
QW361D QW421D
QW481D QW601D

General Notes

- Revised and/or additional pages may be issued from time to time.
- A complete and current manual consists of pages shown in the following contents section.

Contents

Description	Page
Cabinet Components	
♦ Exploded View	2
♦ Usage List	3
♦ Usage List	4
♦ Usage List	5
♦ Usage List	6
♦ Blank Page	7
Functional Components	
♦ Exploded View	8
♦ Usage List	9
♦ Usage List	10
♦ Usage List	11
Upper Control Panel Components	
♦ Exploded View	12
♦ Usage List	13
♦ Usage List	14
♦ Usage List	15
Lower Control Panel Components	
♦ Exploded View	16
♦ Usage List	17
Blower Assembly Components	
♦ Exploded View	18
♦ Usage List	19
Optional Climate Control Components	
♦ Exploded View	20
♦ Usage List	21
Wall Sleeve Cabinet Components	
♦ Exploded View	22
♦ Usage List	23



CLIMATE CONTROL SOLUTIONS

BARD MANUFACTURING COMPANY
Bryan, Ohio 43506
Since 1914...Moving ahead, just as planned.

Manual: 2110-545C
Supersedes: 2110-545B
File: Tab 14
Date: 01-16-06

CABINET COMPONENTS

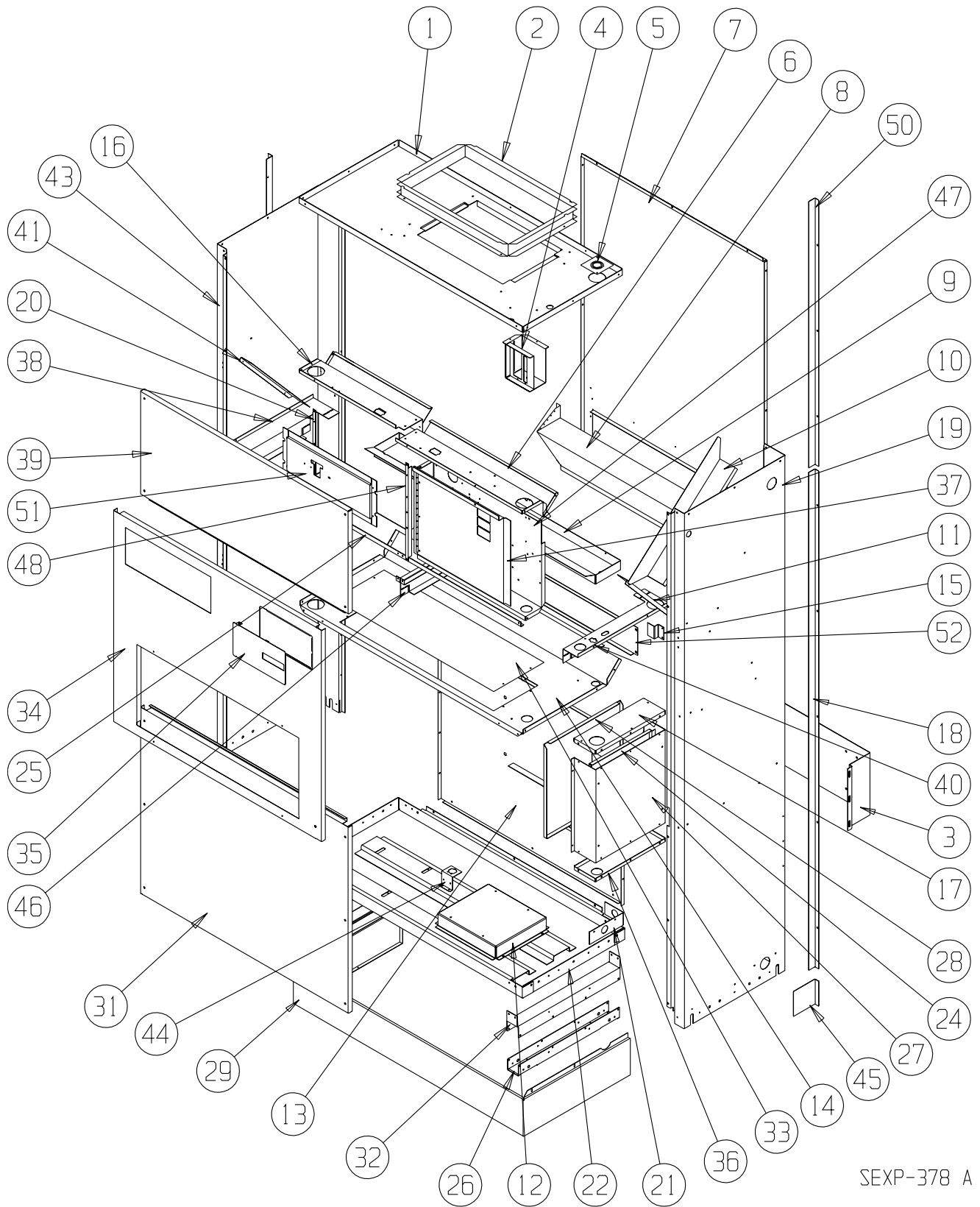

SEXP-378 A

This Exploded View is referenced in Tables on Page 3, 4, 5 & 6

CABINET COMPONENTS

Drawing No.	Part No.	Description	QW242DA, DB	QW242DC	QW302DA, DB	QW302DC	QW361DA, DB	QW361DC	QW421DA, DB	QW421DC
1	506-225	Top Assembly	X	X	X	X	X	X	X	X
2	110-044	Outlet Duct Flange	2	2	2	2	2	2	2	2
3	112-289	Wall Mounting Bracket	2	2	2	2	2	2	2	2
4	117-187	Low Voltage Box Assembly (Optional)	X	X	X	X	X	X	X	X
5	136-359	T. K. O. Plate	X	X	X	X	X	X	X	X
6	534-191	Evaporator Coil Shield – Right	X	X	X	X	X	X	X	X
7	508-133	Back Assembly	X	X	X	X	X	X	X	X
8	538-106	Fresh Air Damper Assembly	X	X	X	X	X	X	X	X
9	523-104	Evaporator Drain Pan Assembly	X	X	X	X	X	X	X	X
10	134-154	Wire Channel	X	X	X	X	X	X	X	X
11	140X277	Right Evaporator Support	X	X	X	X	X	X	X	X
12	140-278	Water Coil Hold Down		X		X		X		X
12	140-026	Water Coil Hold Down	X		X		X		X	
13	508-164	Lower Back	X	X	X	X	X	X	X	X
14	520-346	Condenser Partition Assembly	X	X	X	X	X	X	X	X
15	103-443	Door Latch Offset	X	X	X	X	X	X	X	X
16	534-190	Evaporator Coil Shield – Left	X	X	X	X	X	X	X	X
17	117-237	Lower Control Panel Top	X	X	X	X	X	X	X	X
18	135-177-* ①	Side Trim – Lower	2	2	2	2	2	2	2	2
19	500-392-* ①	Right Side Assembly	X	X	X	X	X	X	X	X
20	104-1096	Right Thermostat Support Angle	X	X	X	X	X	X	X	X
21	112-278	Drain Bracket	X	X	X	X	X	X	X	X
22	527-310-X	Lower Base Assembly	X	X	X	X	X	X	X	X
24	117-240	Lower Control Panel Plate	X	X	X	X	X	X	X	X
25	104-1097	Front Filter Angle	X	X	X	X	X	X	X	X
26	140-276	Lower Roller Support	2	2	2	2	2	2	2	2
27	See Page 12	Control Panel Components	X	X	X	X	X	X	X	X
28	133-164	Control Panel Door – Lower	X	X	X	X	X	X	X	X
29	534-155-6	Base Trim Assembly	X	X	X	X	X	X	X	X
31	552-339-* ①	Condenser Door Assembly	X	X	X	X	X	X	X	X
32	140-280	Upper Roller Support	2	2	2	2	2	2	2	2
33	536-351	Condenser Blank Off Plate	X	X	X	X	X	X	X	X
34	552-330-* ①	Filter Door Assembly	X	X	X	X	X	X	X	X
35	153-336-* ①	Circuit Breaker Door	X	X	X	X	X	X	X	X

Continued on Page 4

- ① Exterior cabinet parts are manufactured with various color options. To insure that you receive the proper color, you must include the complete models and serial number of the unit for which parts are being ordered.

This Table references Exploded View on Page 2

CABINET COMPONENTS

Drawing No.	Part No.	Description	QW242DA, DB	QW242DC	QW302DA, DB	QW302DC	QW361DA, DB	QW361DC	QW421DA, DB	QW421DC
<i>Continued from Page 3</i>										
36	117-238	Lower Control Panel Bottom	X	X	X	X	X	X	X	X
37	132-173	Disconnect Door Inner		X		X		X		X
37	132-165	Circuit Breaker Door Inner	X		X		X		X	
38	113-281	Left Filter Bracket	X	X	X	X	X	X	X	X
39	552-331-* ①	Blower Door Assembly	X	X	X	X	X	X	X	X
40	113-282	Right Filter Bracket	X	X	X	X	X	X	X	X
41	140Y277	Left Evaporator Support	X	X	X	X	X	X	X	X
43	500-391-* ①	Left Side Assembly	X	X	X	X	X	X	X	X
44	113-142	Expansion Valve Mounting Plate	X	X	X	X	X	X	X	X
45	135-165-* ①	Base Trim Extension	2	2	2	2	2	2	2	2
46	112X283	Center Right Filter Bracket	X	X	X	X	X	X	X	X
46	112Y283	Center Left Filter Bracket	X	X	X	X	X	X	X	X
47	See Page 13	Pull Disconnect Assembly		X		X		X		X
47	See Page 13	Circuit Breaker Box Assembly	X		X		X		X	
48	104-1096	Left Thermostat Support Bracket	X	X	X	X	X	X	X	X
50	135-178-* ①	Side Trim – Upper	2	2	2	2	2	2	2	2
51	See Page 20	Thermostat Mounting Plate	X	X	X	X	X	X	X	X
52	542-077	Discharge Blank Off Plate	X	X	X	X	X	X	X	X

- ① Exterior cabinet parts are manufactured with various color options. To insure that you receive the proper color, you must include the complete models and serial number of the unit for which parts are being ordered.

This Table references Exploded View on Page 2

CABINET COMPONENTS

Drawing No.	Part No.	Description	QW481DA, DB QW601DA, DB	QW481DC QW601DC
1	506-225	Top Assembly	X	X
2	110-044	Outlet Duct Flange	2	2
3	112-289	Wall Mounting Bracket	2	2
4	117-187	Low Voltage Box Assembly (Optional)	X	X
5	136-359	T. K. O. Plate	X	X
6	534-191	Evaporator Coil Shield – Right	X	X
7	508-133	Back Assembly	X	X
8	538-106	Fresh Air Damper Assembly	X	X
9	523-104	Evaporator Drain Pan Assembly	X	X
10	134-154	Wire Channel	X	X
11	140X277	Right Evaporator Support	X	X
12	140-288	Water Coil Hold Down		X
12	140-026	Water Coil Hold Down	X	
13	508-164	Lower Back	X	X
14	520-346	Condenser Partition Assembly	X	X
15	103-443	Door Latch Offset	X	X
16	534-190	Evaporator Coil Shield – Left	X	X
17	117-237	Lower Control Panel Top	X	X
18	135-177-* ①	Side Trim – Lower	2	2
19	500-392-* ①	Right Side Assembly	X	X
20	104-1096	Right Thermostat Support Angle	X	X
21	112-278	Drain Bracket	X	X
22	527-310-X	Lower Base Assembly	X	X
24	117-240	Lower Control Panel Plate	X	X
25	104-1097	Front Filter Angle	X	X
26	140-276	Lower Roller Support	2	2
27	See Page 8	Control Panel Components	X	X
28	133-164	Control Panel Door – Lower	X	X
29	534-155-* ①	Base Trim Assembly	X	X
31	552-339-* ①	Condenser Door Assembly	X	X
32	140-280	Upper Roller Support	2	2
33	536-351	Condenser Blank Off Plate	X	X
34	552-330-* ①	Filter Door Assembly	X	X
35	153-336-* ①	Circuit Breaker Door	X	X

Continued on Page 6

- ① Exterior cabinet parts are manufactured with various color options. To insure that you receive the proper color, you must include the complete models and serial number of the unit for which parts are being ordered.

This Table references Exploded View on Page 2

CABINET COMPONENTS

Drawing No.	Part No.	Description	QW481DA, DB QW601DA, DB		QW481DC QW601DC	
<i>Continued from Page 5</i>						
36	117-238	Lower Control Panel Bottom		X		X
37	132-173	Disconnect Door Inner				X
37	132-165	Circuit Breaker Door Inner		X		
38	112-281	Left Filter Bracket		X		X
39	552-331-* ①	Blower Door Assembly		X		X
40	112-286	Right Filter Bracket		X		X
41	140Y277	Left Evaporator Support		X		X
43	500-393-* ①	Left Side Assembly		X		X
44	113-142	Expansion Valve Mounting Plate		X		X
45	134-165-* ①	Base Trim Extension		2		2
46	112X283	Center Right Filter Bracket		X		X
46	112Y283	Center Left Filter Bracket		X		X
47	See Page 13	Pull Disconnect Assembly				X
47	See Page 13	Circuit Breaker Box Assembly		X		
48	104-1096	Left Thermostat Support Offset		X		X
50	135-178-* ①	Side Trim – Upper		2		2
51	See page 20	Thermostat Mounting Plate		X		X
52	542-077	Discharge Blank Off Plate		X		X

- ① Exterior cabinet parts are manufactured with various color options. To insure that you receive the proper color, you must include the complete models and serial number of the unit for which parts are being ordered.

This Table references Exploded View on Page 2

This page has been left blank intentionally.

FUNCTIONAL COMPONENTS

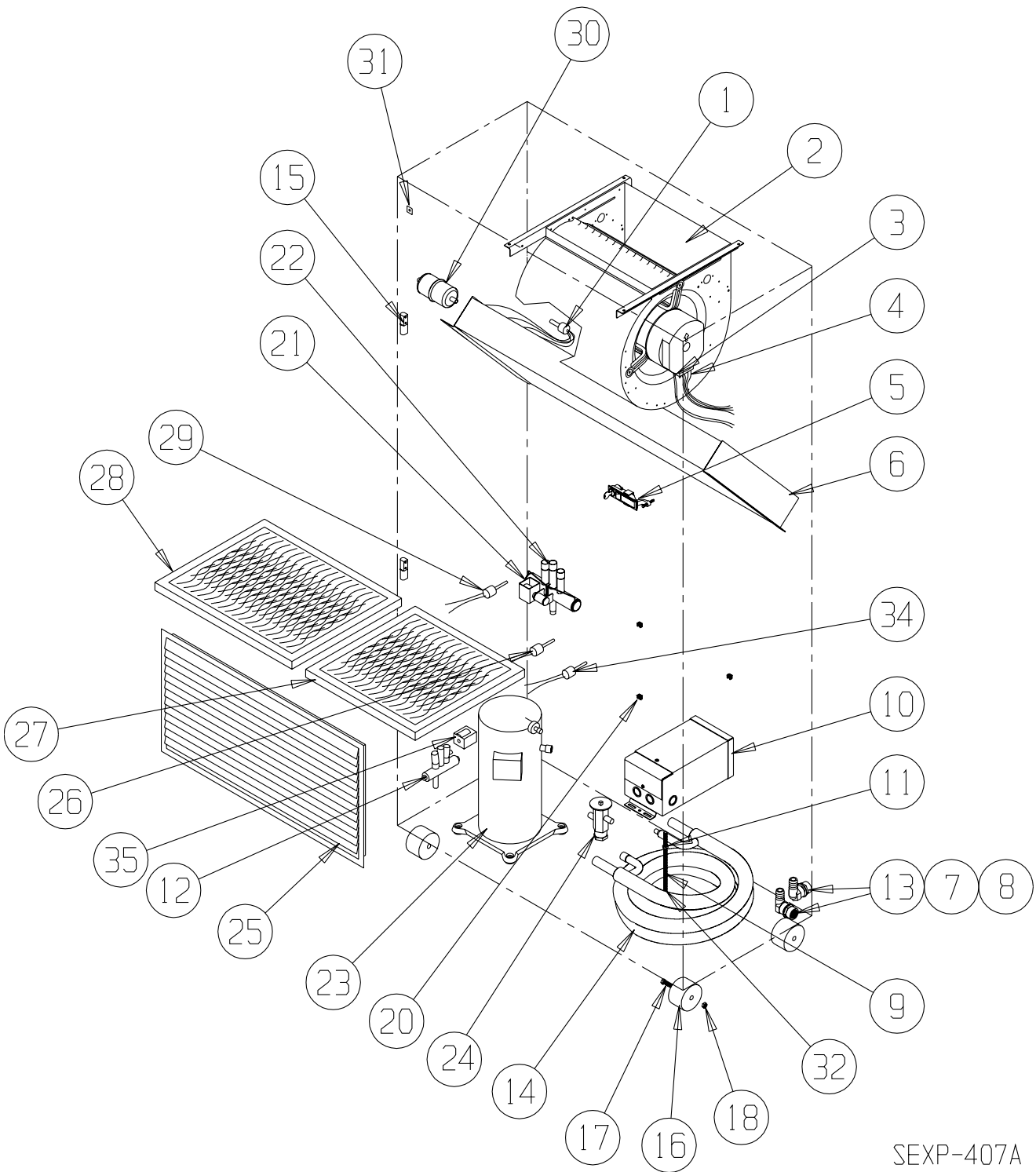

SEXP-407A

This Exploded View is referenced in Tables on pages 9, 10 & 11

FUNCTIONAL COMPONENTS



Drawing No.	Part No.	Description	QW242DA	QW242DB	QW242DC	QW302DA	QW302DB	QW302DC	QW361DA	QW361DB	QW361DC	QW421DA	QW421DB	QW421DC
1	5625-015	Distributor Cooling	X	X	X	X	X	X	X	X	X	X		
1	5625-020	Distributor Cooling											X	X
2	900-225-001	Blower Assembly	X	X	X									
2	900-225-002	Blower Assembly				X	X	X						
2	900-225-004	Blower Assembly							X	X	X	X	X	X
3	3000-1145	Wire Harness High Voltage			X			X			X			X
3	3000-1046	Wire Harness High Voltage	X	X		X	X		X	X		X	X	
4	3000-1042	Wire Harness Low Voltage	X	X	X	X	X	X	X	X	X	X	X	X
5	1171-049	Keylatch/Circuit Breaker Door	X	X	X	X	X	X	X	X	X	X	X	X
6	917-0082	Evaporator Coil	X	X	X	X	X	X	X	X				
6	917-0083	Evaporator Coil										X	X	X
7	6094-008	Drain Adapter	2	2	2	2	2	2	2	2	2	2	2	2
8	6094-007	Drain Elbow	2	2	2	2	2	2	2	2	2	2	2	2
9	1012-078	Rod	X	X	X	X	X	X	X	X	X	X	X	X
10	See Page 15	Transformer			X			X			X			X
11	1012-211	Nut	X	X	X	X	X	X	X	X	X	X	X	X
12	5650-045	Three Way Valve	X	X	X	X	X	X	X	X	X	X	X	X
13	6094-003	Drain Fitting	2	2	2	2	2	2	2	2	2	2	2	2
14	917-0054	Water Coil Assembly	X	X	X									
14	917-0063	Water Coil Assembly				X	X	X						
14	914-0055	Water Coil Assembly							X	X	X	X	X	X
14	917-0071	Copper Water Coil Assy. (Opt.) ^①	X	X	X									
14	917-0073	Copper Water Coil Assy. (Opt.) ^①				X	X	X						
14	917-0072	Copper Water Coil Assy. (Opt.) ^①							X	X	X	X	X	X
15	5400-005	Hinge	2	2	2	2	2	2	2	2	2	2	2	2
16	1171-035	Wheel	4	4	4	4	4	4	4	4	4	4	4	4
17	1012-129	Bolt - Shoulder	4	4	4	4	4	4	4	4	4	4	4	4
18	1012-224	Nut - Locking	4	4	4	4	4	4	4	4	4	4	4	4
20	1012-218	Cage Nut	4	4	4	4	4	4	4	4	4	4	4	4
21	5650-027	Reversing Valve Solenoid	X	X	X	X	X	X	X	X	X	X	X	X
22	5650-032	Reversing Valve	X	X	X	X	X							
22	5650-031	Reversing Valve						X	X	X				
22	5650-030	Reversing Valve										X	X	X
23	8000-258	Compressor	X											
23	8000-231	Compressor		X										
23	8000-232	Compressor			X									
23	8000-259	Compressor				X								
23	8000-201	Compressor					X							
23	8000-202	Compressor						X						
23	8000-203	Compressor							X					
23	8000-204	Compressor								X				
23	8000-175	Compressor									X			
23	8000-163	Compressor										X		
23	8000-164	Compressor											X	X
24	5651-150	TXV	X	X	X									
24	5651-151	TXV				X	X	X						
24	5651-152	TXV							X	X	X			
24	5651-153	TXV										X	X	X
25	7051-034	Return Air Grille	X	X	X	X	X	X	X	X	X	X	X	X

Continued on Page 10

① NOTE: The fourteenth character in the unit model number indicates coil option; option "X" is for the standard Cupronickel coil and "4" indicates copper coil.

This Table references Exploded View on Page 8

FUNCTIONAL COMPONENTS

Drawing No.	Part No.	Description	QW242DA	QW242DB	QW242DC	QW302DA	QW302DB	QW302DC	QW361DA	QW361DB	QW361DC	QW421DA	QW421DB	QW421DC
<i>Continued from Page 9</i>														
26	8406-055	 High Pressure Control	X	X	X	X	X	X	X	X	X	X	X	X
27	7004-009	Air Filter	X	X	X	X	X	X	X	X	X	X	X	X
27	7004-032	Filter 2" Fiberglass (Optional)	X	X	X	X	X	X	X	X	X	X	X	X
27	7004-034	Filter 2" Pleated (Optional)	X	X	X	X	X	X	X	X	X	X	X	X
28	7004-010	Air Filter	X	X	X	X	X	X	X	X	X	X	X	X
28	7004-033	Filter 2" Fiberglass (Optional)	X	X	X	X	X	X	X	X	X	X	X	X
28	7004-035	Filter 2" Pleated (Optional)	X	X	X	X	X	X	X	X	X	X	X	X
29	8406-061	 Low Pressure Control 15 PSI	X	X	X	X	X	X	X	X	X	X	X	X
30	5201-009	Filter / Drier	X	X	X	X	X	X	X	X	X	X	X	X
31	1012-315	"U" Clip Fastener	10	10	10	10	10	10	10	10	10	10	10	10
32	1012-226	Cage Nut	X	X	X	X	X	X	X	X	X	X	X	X
33	800-0317	Drain Back Orifice	X	X	X	X	X	X	X	X	X	X	X	X
34	8406-104	Low Pressure Control 27 PSI	X	X	X	X	X	X	X	X	X	X	X	X
35	5650-042	Rev. Valve Solenoid, Red Casing (Ranco)	X	X	X	X	X	X	X	X	X	X	X	X
35	5650-043	Rev. Valve Solenoid, Black Casing (Wilspec)	X	X	X	X	X	X	X	X	X	X	X	X
NS	CMA-6	Low Ambient Control	X	X	X	X	X	X	X	X	X	X	X	X
NS	4100-115	Wiring Diagram	X			X			X			X		
NS	4100-215	Wiring Diagram		X			X			X			X	
NS	4100-315	Wiring Diagram			X			X			X			X

These Tables reference Exploded View on Page 8

FUNCTIONAL COMPONENTS

Drawing No.	Part No.	Description	QW481DA	QW481DB	QW481DC	QW601DA	QW601DB	QW601DC
1	5625-020	Cooling Distributor	X	X	X	X	X	X
2	900-225-005	Blower Assembly	X	X	X			
2	900-254-002	Blower Assembly				X	X	X
3	3000-1145	Wire Harness High Voltage			X			X
3	3000-1046	Wire Harness High Voltage	X	X		X	X	
4	3000-1170	Wire Harness Low Voltage	X	X	X	X	X	X
5	1171-049	Keylatch/Circuit Breaker Door	X	X	X	X	X	X
6	917-0083	Evaporator Coil	X	X	X			
6	917-0084	Evaporator Coil				X	X	X
7	6094-008	Drain Adapter	2	2	2	2	2	2
8	6094-007	Drain Elbow	2	2	2	2	2	2
9	1012-078	Rod	X	X	X	X	X	X
10	See Page 15	Transformer			X			X
11	1012-211	Nut	X	X	X	X	X	X
12	5650-045	Three Way Valve	X	X	X	X	X	X
13	6094-003	Drain Fitting	2	2	2	2	2	2
14	917-0055	Water Coil Assembly	X	X	X			
14	917-0064	Water Coil Assembly				X	X	X
14	917-0072	Copper Water Coil Assy. (Optional) ①	X	X	X			
14	917-0074	Copper Water Coil Assy. (Optional) ①				X	X	X
15	5400-005	Hinge	2	2	2	2	2	2
16	1171-035	Wheel	4	4	4	4	4	4
17	1012-129	Bolt - Shoulder	4	4	4	4	4	4
18	1012-224	Nut - Locking	4	4	4	4	4	4
20	1012-218	Cage Nut	4	4	4	4	4	4
21	5650-027	Reversing Valve Solenoid	X	X	X	X	X	X
22	5650-030	Reversing Valve	X	X	X	X	X	X
23	8000-176	Compressor						
23	8000-229	Compressor						
23	8000-230	Compressor						
23	8000-178	Compressor	X					
23	8000-249	Compressor		X				
23	8000-250	Compressor			X			
24	5651-162	TXV	X	X	X	X	X	X
25	7051-039	Return Air Grille	X	X	X	X	X	X
26	8406-055	High Pressure Control	X	X	X	X	X	X
27	7004-009	Air Filter	X	X	X	X	X	X
27	7004-032	Filter 2" Fiberglass (Optional)	X	X	X	X	X	X
27	7004-034	Filter 2" Pleated (Optional)	X	X	X	X	X	X
28	7004-011	Air Filter	X	X	X	X	X	X
28	7004-036	Filter 2" Fiberglass (Optional)	X	X	X	X	X	X
28	7004-037	Filter 2" Pleated (Optional)	X	X	X	X	X	X
29	8406-061	Low Pressure Control 15 PSI	X	X	X	X	X	X
30	5201-009	Filter / Drier	X	X	X	X	X	X
31	1012-315	"U" Clip Fastener	10	10	10	10	10	10
32	1012-226	Cage Nut	X	X	X	X	X	X
33	800-0317	Drain Back Orifice	X	X	X	X	X	X
34	8406-104	Low Pressure Control 27 PSI	X	X	X	X	X	X
35	5650-042	Rev. Valve Solenoid, Red Casing (Ranco)	X	X	X	X	X	X
35	5650-043	Rev. Valve Solenoid, Black Casing (Wilspec)	X	X	X	X	X	X
NS	CMA-6	Low Ambient Control	X	X	X	X	X	X
NS	4100-115	Wiring Diagram	X			X		
NS	4100-215	Wiring Diagram		X			X	
NS	4100-315	Wiring Diagram			X			X

① NOTE: The fourteenth character in the unit model number indicates coil option; option "X" is for the standard Cupronickel coil and "4" indicates copper coil.

These Tables reference Exploded View on Page 8

UPPER CONTROL PANEL COMPONENTS

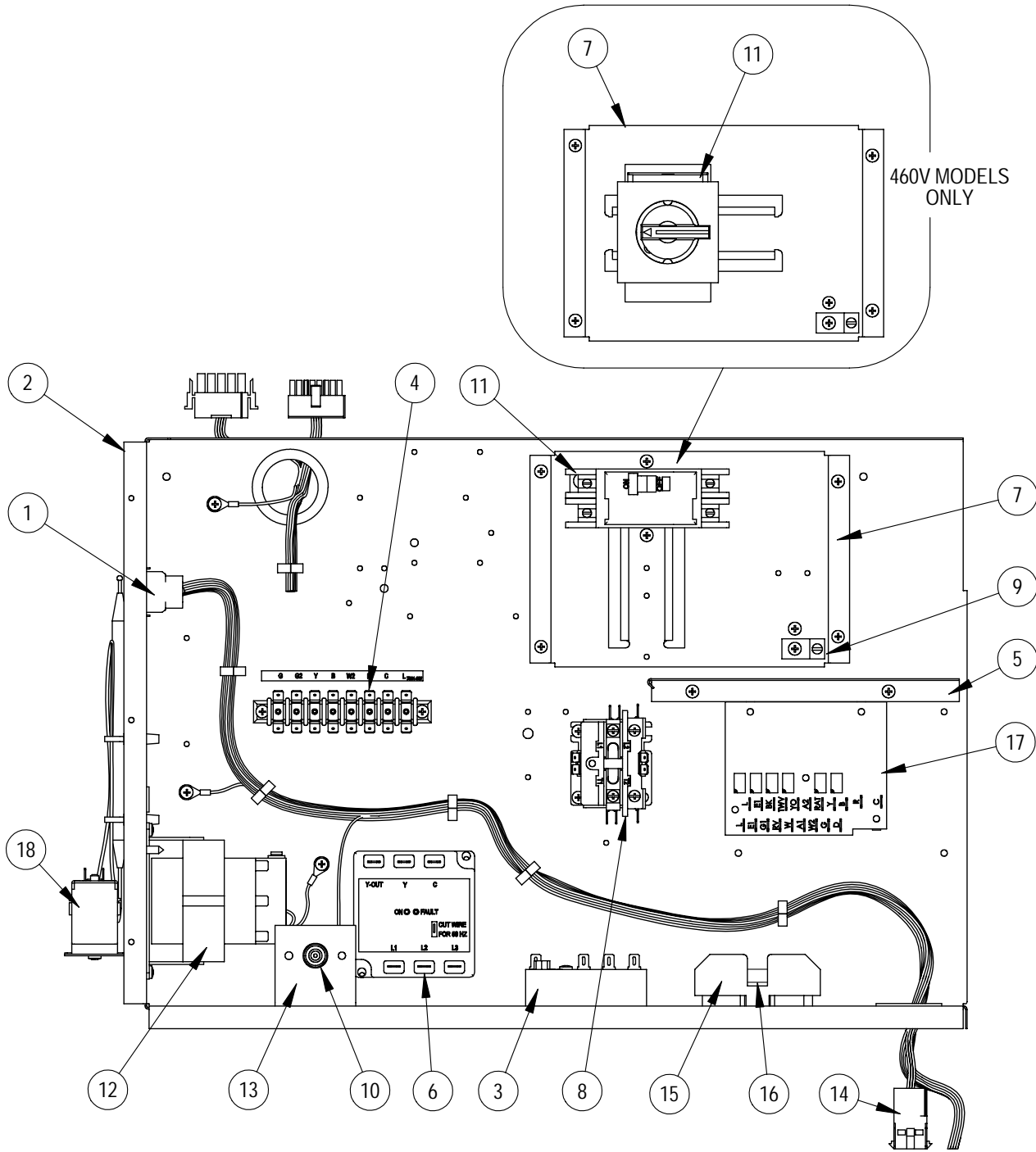

SEXP-408 A

This Exploded View is referenced in Tables on pages 13, 14 & 15

UPPER CONTROL PANEL COMPONENTS

Drawing No.	Part No.	Description	QW242DA0Z	QW302DA0Z	QW361DA0Z	QW421DA0Z	QW481DA0Z	QW601DA0Z
1	3000-1169	Wire Set PL2	X	X	X	X	X	X
2	117-241	Control Panel	X	X	X	X	X	X
3	8201-088	Compressor Control Module	X	X	X	X	X	X
4	8607-022	Terminal Block	X	X	X	X	X	X
5	117-242	Box Partition	X	X	X	X	X	X
7	126-267	Circuit Breaker Base	X	X	X	X	X	X
8	8401-007	Contactora	X	X	X	X		
8	8401-016	Contactora					X	X
9	8611-006	Ground Lug	X	X	X	X	X	X
10	8611--094	Light	X	X	X	X	X	X
11	8615-036	Circuit Breaker 2 Pole 25A Ckt A	X					
11	8615-037	Circuit Breaker 2 Pole 30A Ckt A		X	X			
11	8615-055	Circuit Breaker 2 Pole 40A Ckt A				X		
11	8615-039	Circuit Breaker 2 Pole 45A Ckt A					X	
11	8615-041	Circuit Breaker 2 Pole 60A Ckt A						X
12	8407-048	Transformer	X	X	X	X	X	X
13	112-225	Bracket	X	X	X	X	X	X
14	3000-1173	Wire Set	X	X	X	X	X	X
17	8201-092	Relay Logic Board	X	X	X	X	X	X
18	8408-037	Return Air Thermostat	X	X	X	X	X	X
NS	4101-100	Wiring Diagram	X	X	X	X	X	X

NS = Not Shown

This Table references Exploded View on Page 12

UPPER CONTROL PANEL COMPONENTS

Drawing No.	Part No.	Description	QW242DB0Z	QW302DB0Z	QW361DB0Z	QW421DB0Z	QW481DB0Z	QW601DB0Z
1	3000-1169	Wire Set PL2	X	X	X	X	X	X
2	117-241	Control Panel	X	X	X	X	X	X
3	8201-088	Compressor Control Module	X	X	X	X	X	X
4	8607-022	Terminal Block	X	X	X	X	X	X
5	117-242	Box Partition	X	X	X	X	X	X
6	8201-085	Phase Monitor	X	X	X	X	X	X
7	126-267	Circuit Breaker Base	X	X	X	X	X	X
8	8401-002	Contactors	X	X	X	X	X	X
9	8611-006	Ground Lug	X	X	X	X	X	X
10	8611-094	Light	X	X	X	X	X	X
11	8615-054	Circuit Breaker 3 Pole 20A	X	X				
11	8615-051	Circuit Breaker 3 Pole 25A			X			
11	8615-052	Circuit Breaker 3 Pole 30A				X		
11	8615-042	Circuit Breaker 3 Pole 35A					X	
11	8615-044	Circuit Breaker 3 Pole 45A						X
12	8407-048	Transformer	X	X	X	X	X	X
13	112-225	Bracket	X	X	X	X	X	X
14	3000-1173	Wire Set PL3	X	X	X	X	X	X
17	8201-092	Relay Logic Board	X	X	X	X	X	X
18	8408-037	Return Air Thermostat	X	X	X	X	X	X
NS	4101-200	Wiring Diagram	X	X	X	X	X	X

NS = Not Shown

This Table references Exploded View on Page 12

UPPER CONTROL PANEL COMPONENTS

Drawing No.	Part No.	Description	QW242DC0Z	QW302DC0Z	QW361DC0Z	QW421DC0Z	QW481DC0Z	QW601DC0Z
1	3000-1169	Wire Set PL2	X	X	X			X
2	117-241	Control Panel	X	X	X			X
3	8201-088	Compressor Control Module	X	X	X			X
4	8607-022	Terminal Block	X	X	X			X
5	117-242	Box Partition	X	X	X			X
6	8201-085	Phase Monitor	X	X	X			X
7	126-323	Pull Disconnect Base	X	X	X			X
8	8401-002	Contactor	X	X	X			X
9	8611-006	Ground Lug	X	X	X			X
10	8611-094	Light	X	X	X			X
11	8615-068	Disconnect	X	X	X			X
12	8407-050	Transformer	X	X	X			X
13	112-225	Bracket	X	X	X			X
14	3000-1173	Wire Set PL3	X	X	X			X
15	8614-041	Fuse Holder	X	X				X
NS	8407-032	Transformer Stepdown 1.0 KVA	X					
NS	8407-003	Transformer Stepdown 1.5 KVA	X	X				
NS	8407-004	Transformer Stepdown 2.0 KVA			X			X
NS	8407-055	Transformer Stepdown 3.0 KVA						X
16	8614-042	Fuses Class CC 7A ①			2			2
16	8614-046	Fuses Class CC 5A ②	2		2			
16	8614-047	Fuses Class CC 3.2A ③	2					
16	8614-043	Fuses Class CC 10A ④						2
17	8201-092	Relay Logic Board	X	X	X			X
18	8408-037	Return Air Thermostat	X	X	X			X
19	8615-071	Disconnect Handle	X	X	X			X
NS	4101-300	Wiring Diagram	X	X	X			X

① 7 Amp fuses used with 2.0 KVA transformer.

② 5 Amp fuses used with 1.5 KVA transformer.

③ 3.2 Amp fuses used with 1KVA transformer.

④ 10 Amp fuses used with 3.0 KVA transformer.

NS = Not Shown

This Table references Exploded View on Page 12

LOWER CONTROL PANEL COMPONENTS

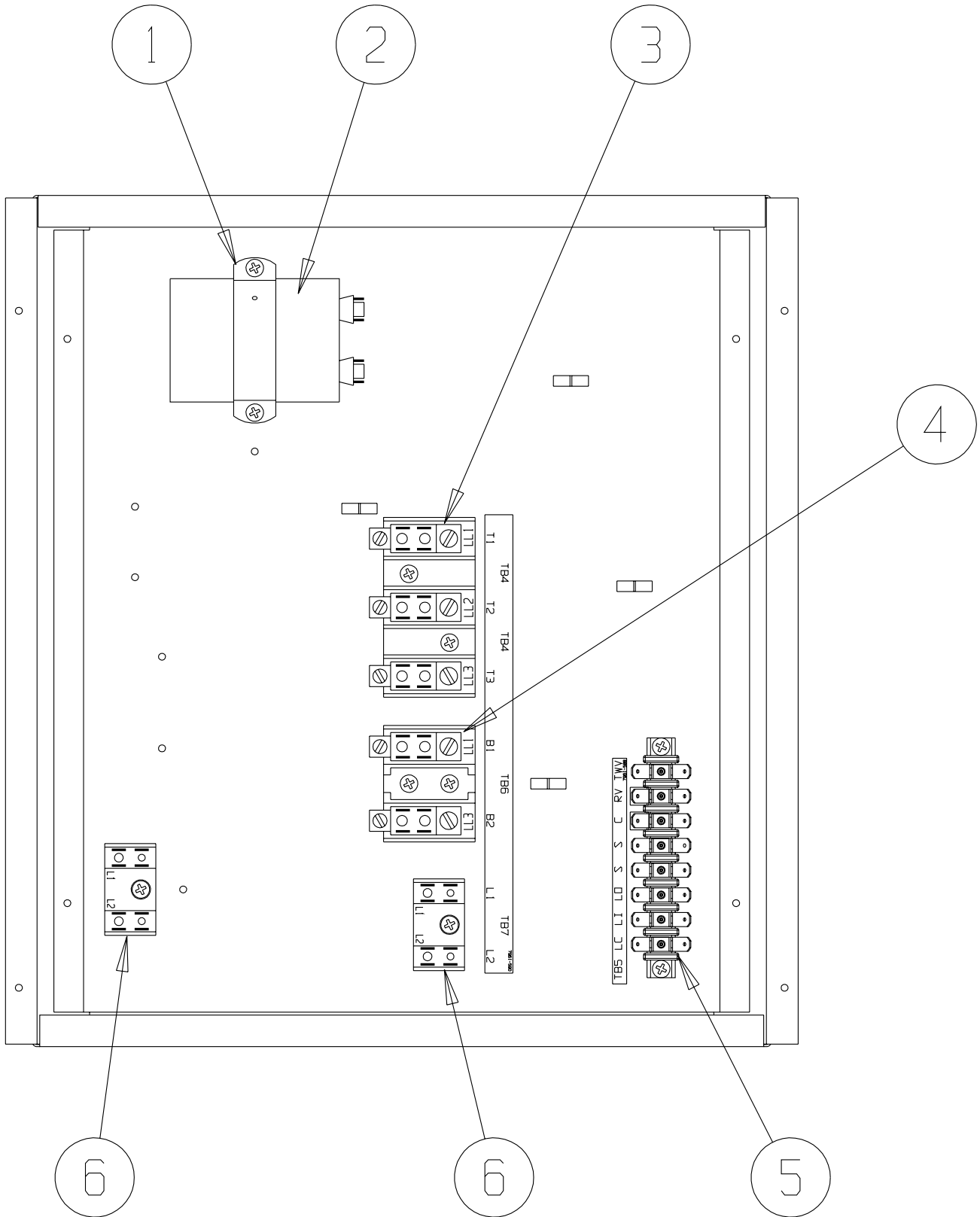

SEXP-381

LOWER CONTROL PANEL COMPONENTS

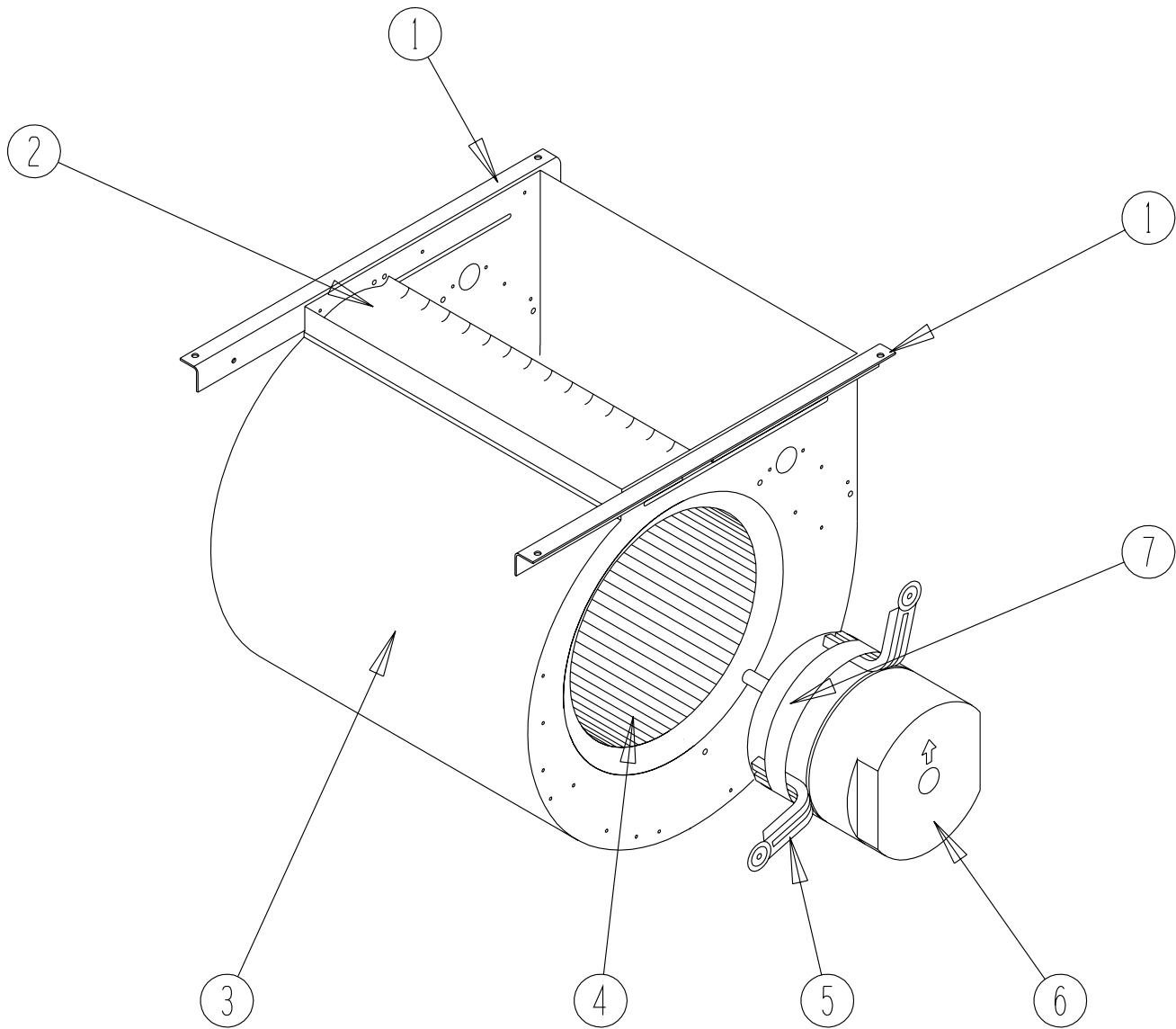

Drawing			QW242DA	QW302DA	QW361DA	QW421DA	QW481DA	QW601DA	QW242DB	QW302DB	QW361DB	QW421DB	QW601DB	QW242DC	QW302DC	QW361DC	QW421DC	QW601DC
No.	Part No.	Description																
1	8552-008 	Capacitor Strap	X	X	X	X	X	X										
2	8552-048	Compressor Capacitor	X	X														
2	8552-043	Compressor Capacitor			X													
2	8552-074	Compressor Capacitor				X												
2	8552-075	Compressor Capacitor					X											
2	8552-058	Compressor Capacitor						X										
3	8607-014	Terminal Block 3 Ter							X							X		
4	8607-013	Terminal Block 2 Ter	X	X	X	X	X	X									X	
5	8607-022	Terminal Block 8 Pos	X	X	X	X	X	X	X								X	
6	8607-017	Terminal Block 2 Ter	X	X	X	X	X	X	X								X	

BLOWER ASSEMBLY COMPONENTS



SEXP-245

BLOWER ASSEMBLY COMPONENTS

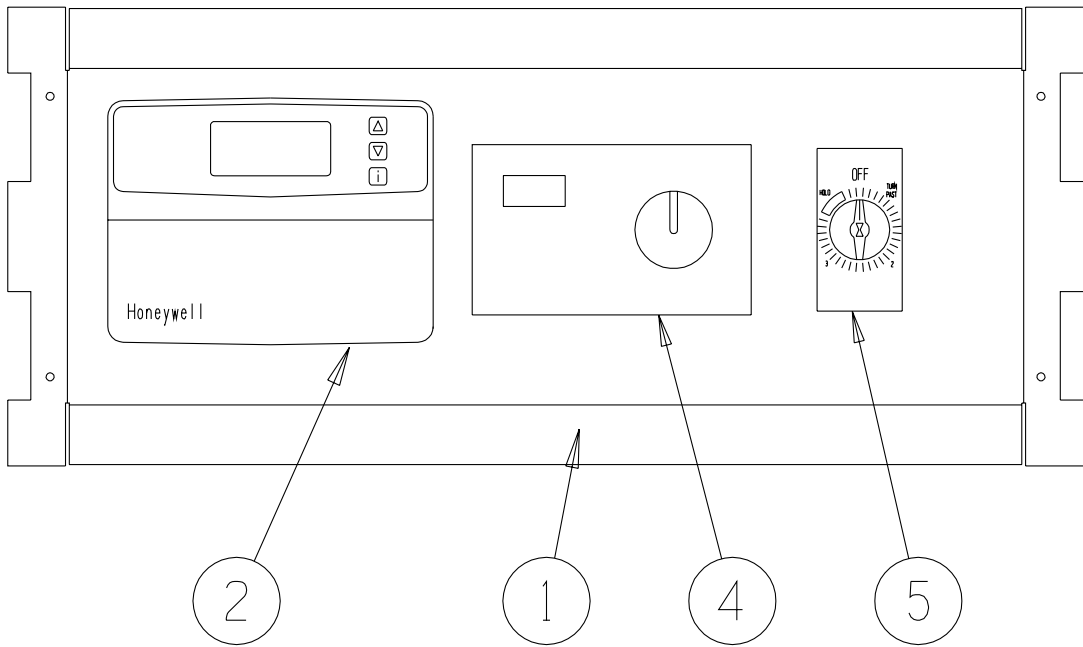
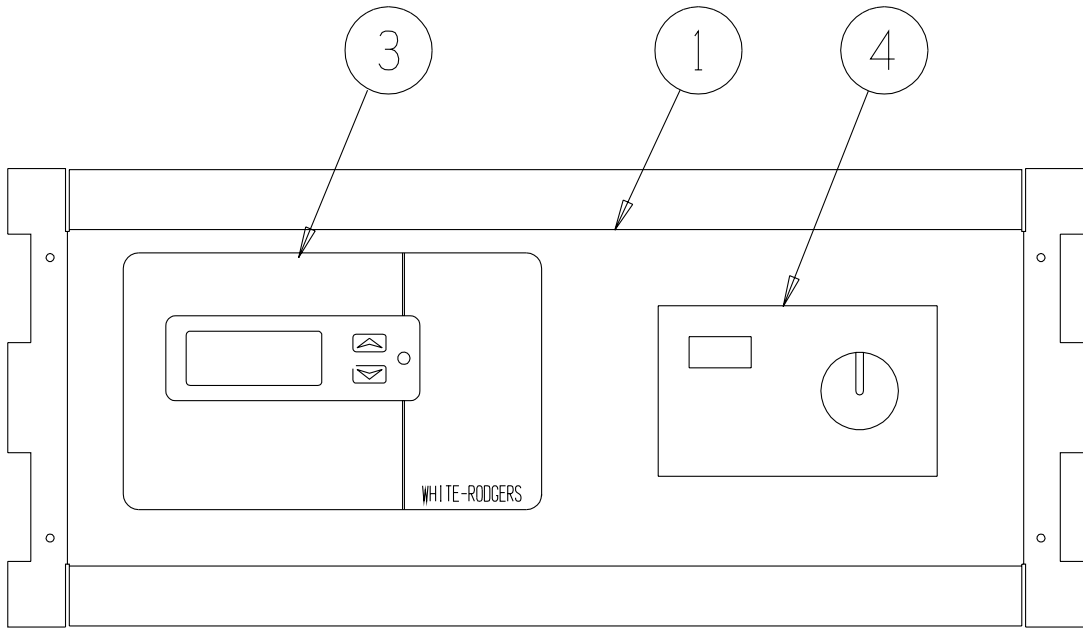

Drawing No.	Part No.	Description	900-225-001	900-225-002	900-225-004	900-225-005	900-254-002
1	104-980	Blower Angle	2	2	2	2	2
2	144-131	Diffuser	X	X	X	X	X
3	151-110	Blower Housing	X	X	X	X	X
4	5152-061	Blower Wheel	X	X	X	X	X
5	8200-034 	Motor Mount Arm	3	3	3	3	3
6	8106-035-0003	Motor	X				
6	8106-035-0004	Motor		X			
6	8106-035-0005A	Motor			X		
6	8106-035-0013	Motor				X	
6	8107-009-0023	Motor					X
7	8200-033 	Motor Mount Band	X	X	X	X	X

OPTIONAL CLIMATE CONTROLS



SEXP-371

OPTIONAL CLIMATE CONTROLS

			QW242D, QW302D QW361D, QW421D QW481D, QW601D			
			Option X	Option E	Option F	Option G
Drawing No.	Part No.	Description				
1	S127-313-* ①	Thermostat Plate	X			
1	S127-314-* ①	Thermostat Plate		X		X
1	S127-312-* ①	Thermostat Plate			X	
2	8403-042	 Electronic / Non-Programmable / Manual / Auto Change Over			X	X
3	8403-049	Electronic / Programmable / Manual / Auto Change Over		X		
4	8403-037	 Humidistat		X	X	X
5	8612-015	Timer			X	
NS	3000-1151	Wire Harness, Low Voltage, Terminal Strip to PL2	X			
NS	3000-1180	Wire Harness, Thermostat to PL2		X		
NS	3000-1179	Wire Harness, Thermostat to PL2			X	
NS	3000-1181	Wire Harness, Thermostat to PL2				X
NS	8607-019	Low Voltage Terminal Strip	X			X
NS	4102-034	Wiring Diagram	X			
NS	4102-032	Wiring Diagram		X		
NS	4102-031	Wiring Diagram			X	
NS	4102-033	Wiring Diagram				X

① Exterior cabinet parts are manufactured with various color options. To insure that you receive the proper color, you must include the complete models and serial number of the unit for which parts are being ordered.

NS Not Shown

CLIMATE CONTROL OPTION NOMENCLATURE AS SHOWN IN UNIT MODEL NUMBER





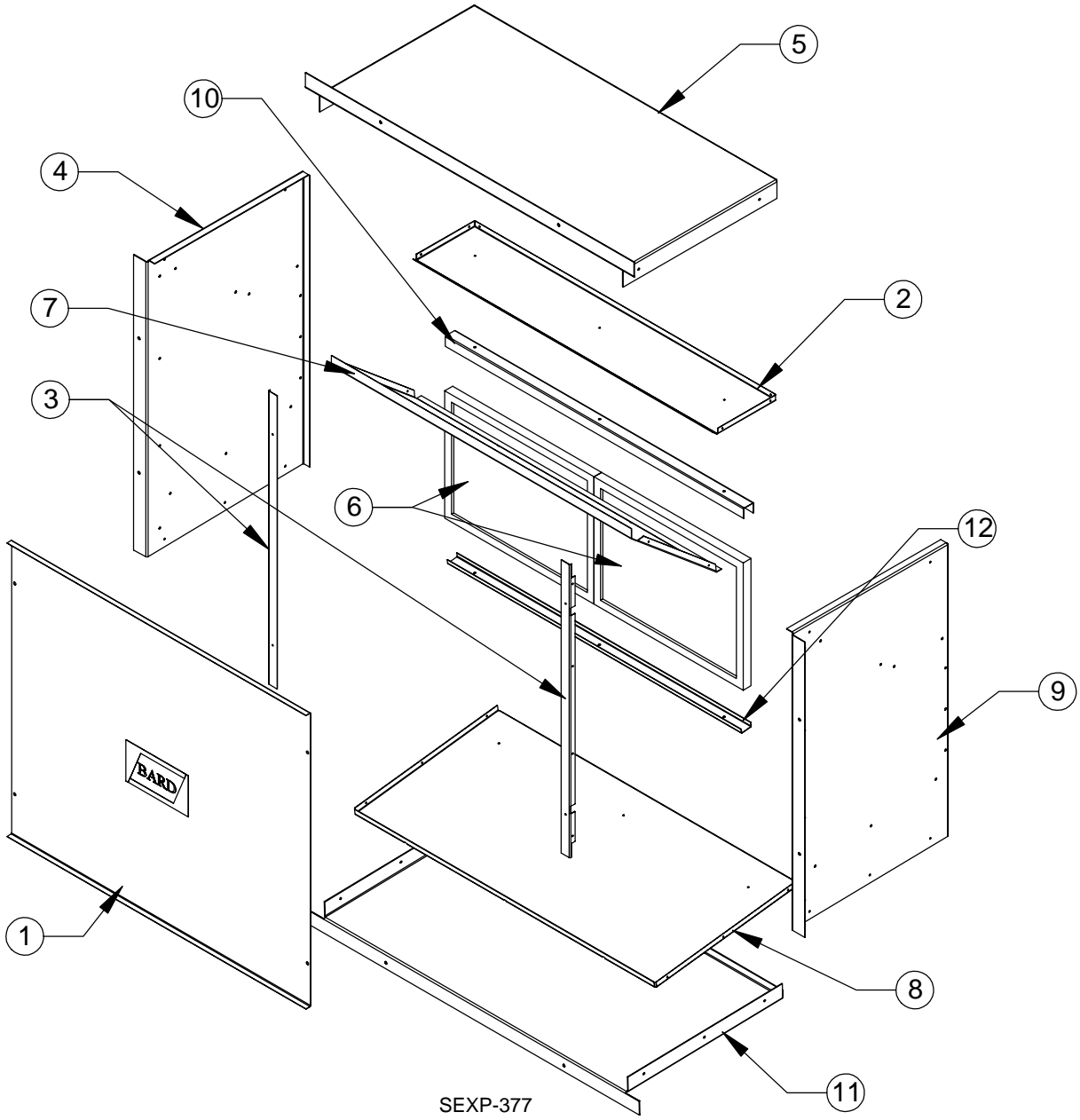

QW 361 - A 02 X X X X X X

- X – None
- E – Electronic, programmable, manual/auto changeover with humidistat
- F – Electronic, non-programmable, manual/auto changeover with timer & humidistat
- G – Electronic, non-programmable manual/auto changeover with humidistat

WALL SLEEVE CABINET COMPONENTS



WALL SLEEVE CABINET COMPONENTS

Drawing No.	Part No.	Description	QWVS42
1	142-076	Cover	X
2	121-350-X	Top Partition	X
3	104-1103	 Angle	2
4	111-072-X	 Left Side	X
5	110-074-X	Top	X
6	7003-056	Mist Eliminator	2
7	111-076-X	Air Deflector	X
8	121-349-X	Partition	X
9	111-073-X	 Right Side	X
10	164-566	 Upper Support Channel	X
11	111-075-X	 Base	X
12	164-567	 Lower Support Channel	X