

---

# REPLACEMENT PARTS MANUAL

# WALL MOUNTED PACKAGE HEAT PUMPS

Models: **WH184**  
**WH242**

---

## General Notes

- Revised and/or additional pages may be issued from time to time.
- A complete and current manual consists of pages shown in the following contents section.

## Important

- Contact the installing and/or local Bard distributor for all parts requirements. Make sure you have the complete model and serial number available from the unit rating plates.

## Contents

Description	Page
Cabinet Components	
♦ Exploded View .....	1
♦ Usage List .....	2
Functional Components	
♦ Exploded View .....	3
♦ Usage List .....	4
Control Panel	
♦ Exploded View .....	5
♦ Usage List .....	6
Blower Assembly	
♦ Exploded View .....	7
♦ Usage List .....	7



BARD MANUFACTURING COMPANY  
Bryan, Ohio 43506  
*Since 1914...Moving ahead, just as planned.*

Manual: 2110-549A  
Supersedes: 2110-549  
File: Tab 17  
Date: 07-15-04

---

# CABINET COMPONENTS

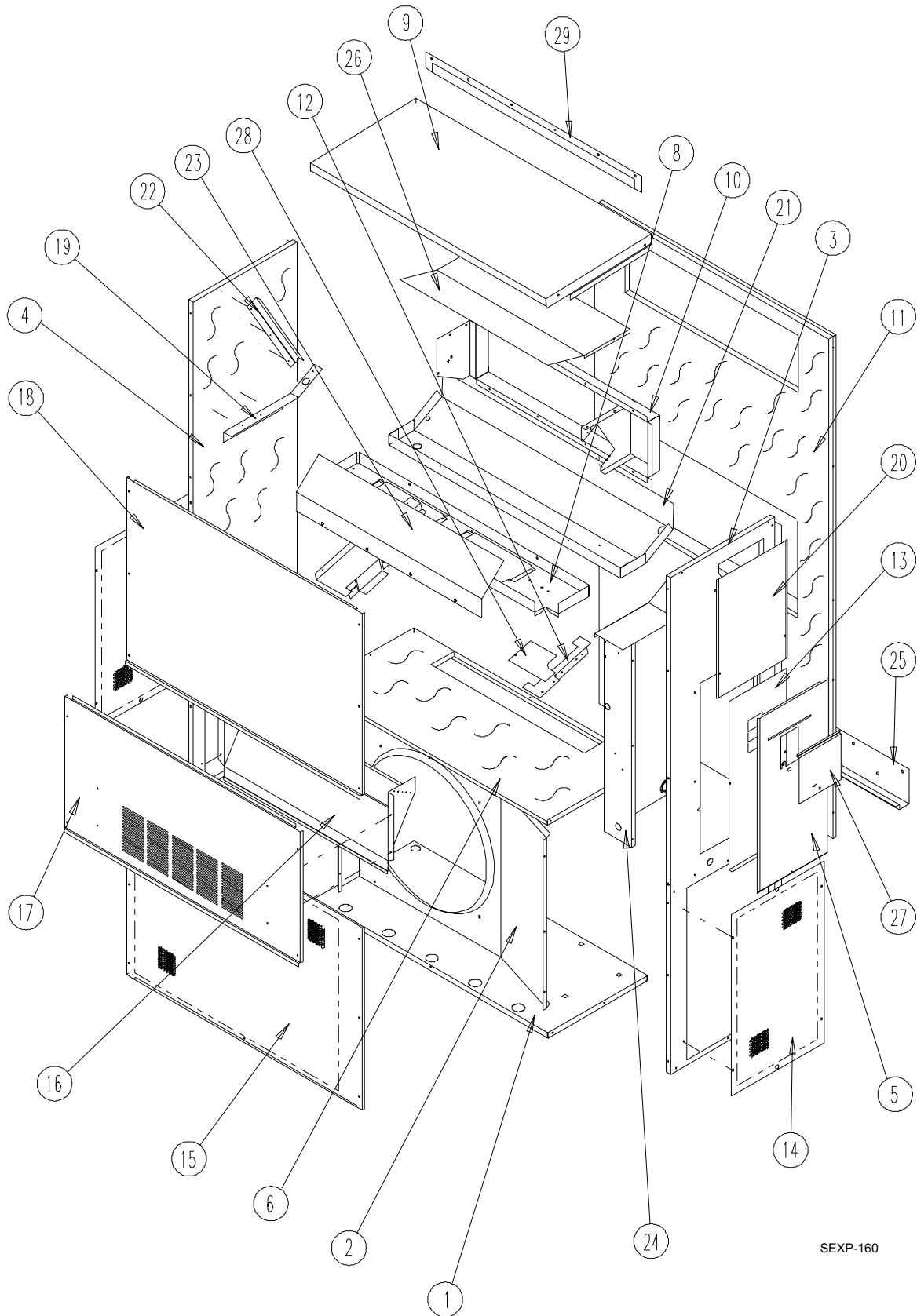

SEXP-160

# CABINET COMPONENTS

Drawing No.	Part No.	Description	WH184-A	WH242-A,B	WH242-C
1	S127-204	Lower Base	X	X	X
2	125-023	Fan Shroud	X	X	X
3	S500-228-* ①	Right Side	X	X	X
4	S500-229-* ①	Left Side	X	X	X
5	S533-109-* ①	Control Panel Cover (Outer)	X	X	X
6	S521X204	Condenser Partition	X	X	X
8	121X336	Blower Partition	X	X	X
9	S506-137-* ①	Top	X	X	X
10	S111-032	Outlet Airframe Assembly	X	X	X
11	S508-097	Back	X	X	X
12	113-195	Filter Bracket	2	2	2
13	S133-104	Control Panel (Inner)	X	X	
13	S133-110	Control Panel (Inner)			X
14	118-056-* ①	Side Grille	2	2	2
15	118-050-* ①	Condenser Grille	X	X	X
16	962019	Fresh Air Damper Assembly	X	X	X
17	S552-213-* ①	Service Door	X	X	X
18	S514-076-* ①	Upper Front	X	X	X
19	105-850	Left Side Support	X	X	X
20	143-034-* ①	Right Side Cover Plate (Outer)	X	X	X
21	S123-080	Drain Pan	X	X	X
22	147-044-* ①	Left Evaporator Support	X	X	X
23	137-195	Bottom Evaporator Fill	X	X	X
24	Control Panel Assembly	See Control Panel Assembly Drawing and Parts List	X	X	X
25	113-140	Bottom Mounting Bracket	1	1	1
26	135-127	Heat Shield	X	X	X
27	S153-218-* ①	Disconnect Access Door	X	X	X
28	137-259	Fill Plate	X	X	X
29	113-141-* ①	Top Rain Flashing	X	X	X

- ① Exterior cabinet parts are manufactured with various paint color options. To insure that you receive the proper paint color, you must include the complete model and serial number of the unit for which cabinet parts are being ordered.

# FUNCTIONAL COMPONENTS

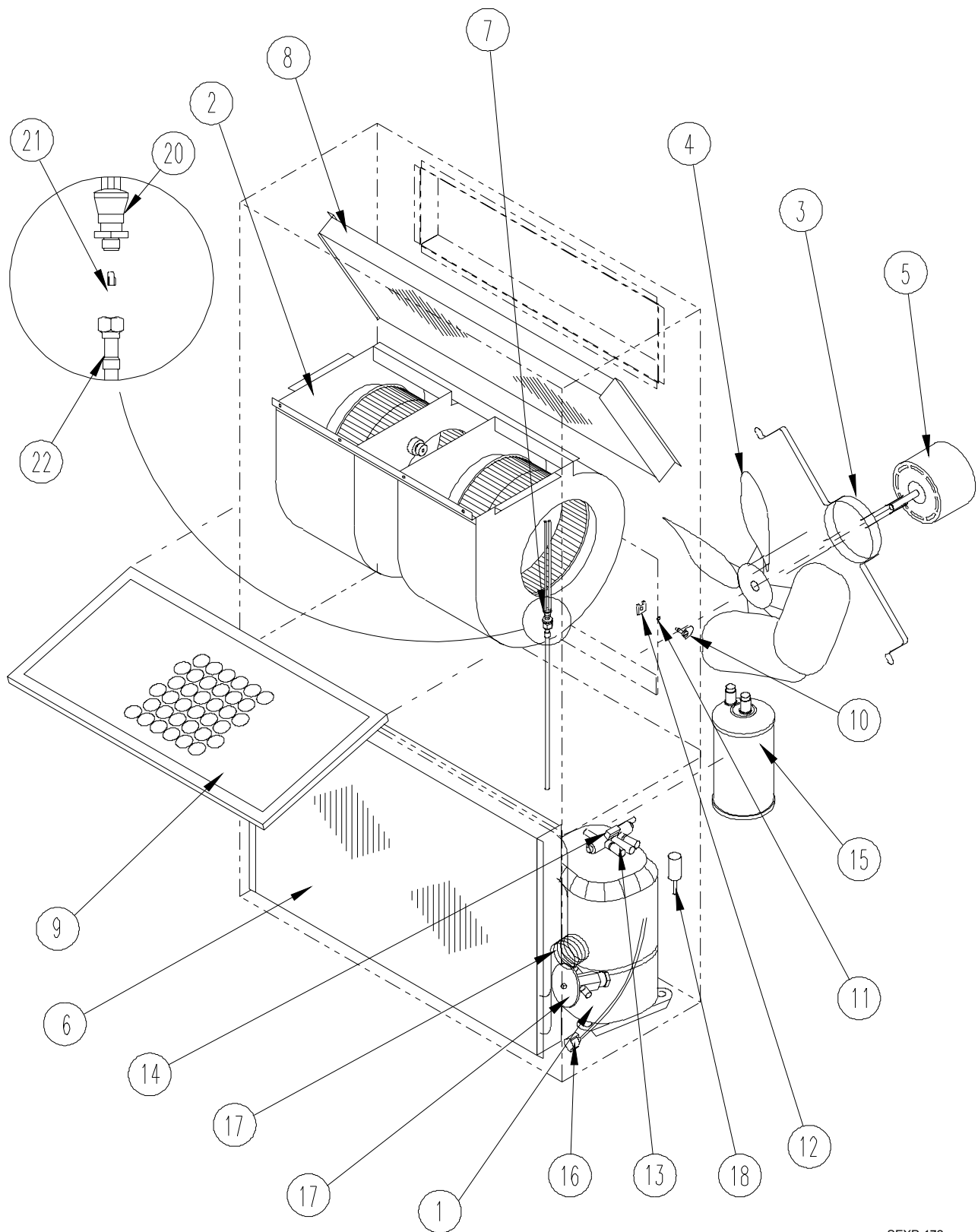

SEXP-172

# FUNCTIONAL COMPONENTS

Drawing No.	Part No.	Description	WH184-A	WH242-A	WH242-B	WH242-C
1	8000-257	Compressor	X			
1	8000-140	Compressor		X		
1	8000-141	Compressor			X	
1	8000-142	Compressor				X
2	S900-248	Blower Assembly	X	X	X	
2	S900-250	Blower Assembly				X
3	8200-001	Fan Motor Mount	X	X	X	X
4	5151-033	Fan Blade	X	X	X	
4	5151-046	Fan Blade				X
5	8103-016	Condenser Motor	X	X	X	
5	8103-020	Condenser Motor				X
6	5051-069	Condenser Coil		X	X	X
6	5051-070	Condenser Coil	X			
7	800-0200	Cooling Capillary Assembly		X	X	X
8	5060-065	Evaporator Coil	X	X	X	X
9	7004-011	Air Filter 1" Throw-Away	X	X	X	X
9	7003-032	Air Filter 1" Washable (Optional)	X	X	X	X
9	7004-025	Air Filter 2" Pleated (Optional)	X	X	X	X
10	1171-022	1/4" Turn Fastener	X	X	X	X
11	1171-024	1/4" Turn Retainer	X	X	X	X
12	1171-023	1/4" Receptacle	X	X	X	X
13	5650-020	Reversing Valve	X	X	X	X
14	5650-022	Reversing Valve Solenoid	X	X	X	X
15	5202-021	Accumulator		X	X	X
16	8408-027	Defrost Sensor	X	X	X	X
17	800-0199	Heating Capillary Assembly		X	X	X
17	5651-094	TXV Thermal Expansion Valve	X			
18	1804-0106	High Pressure Switch (Flare)	X	X	X	X
19	5625-013	Heating Distributor	X			
20	5625-012	Cooling Distributor (Male)	X			
21	5625-052	Cooling Orifice (.052)	X			
22	5625-003	Cooling Distributor (Female)	X			
NS	1804-0107	Low Pressure Switch (Flare)	X	X	X	X
NS	CMA-6	Low Ambient Control (Flare)	X	X	X	X

NS Not Shown

# CONTROL PANEL

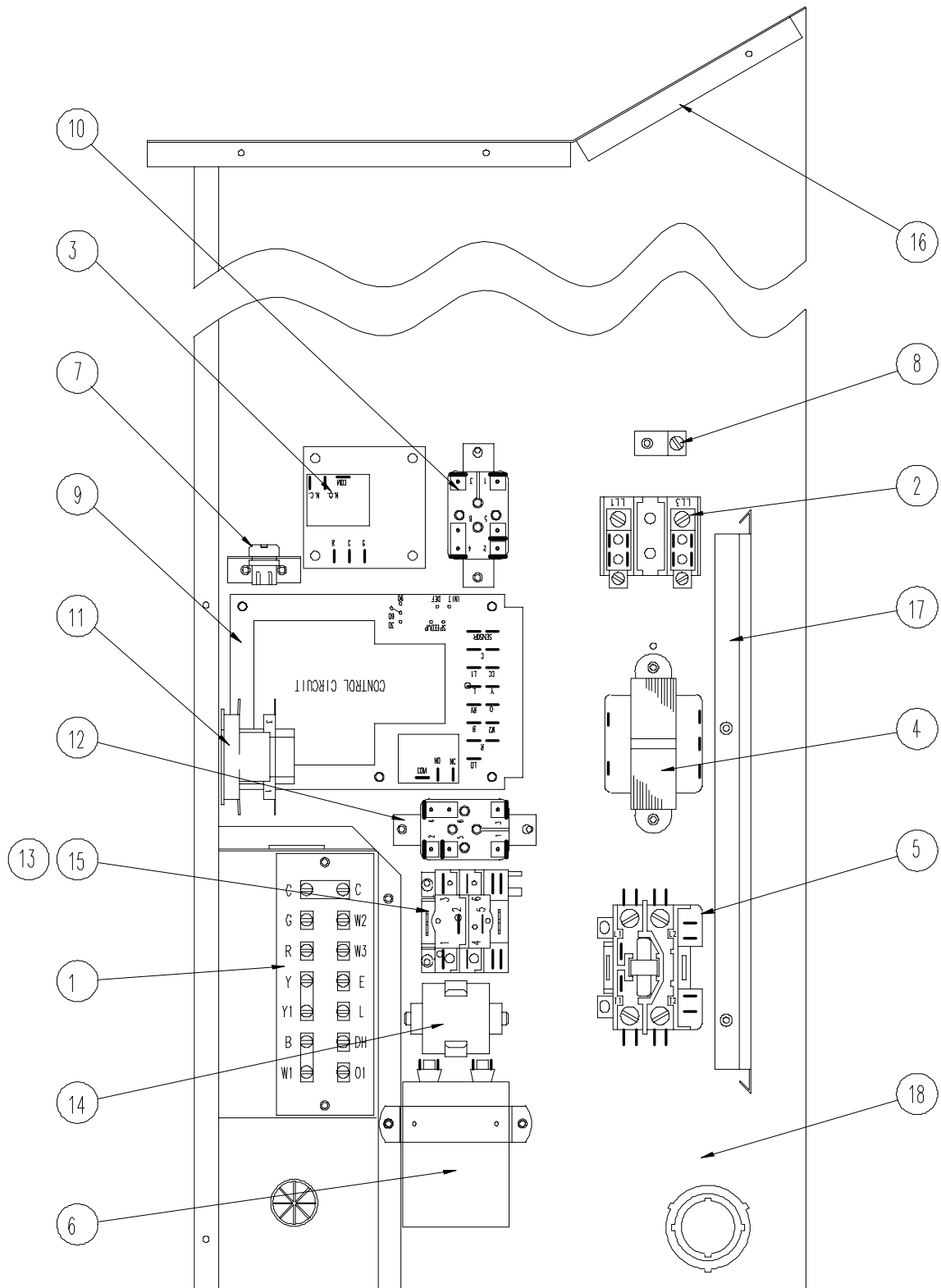

SEXP-168

# CONTROL PANEL

Drawing No.	Part No.	Description	WH184-A	WH242-A	WH242-B	WH242-C
1	8607-019	Low Voltage Terminal Strip	X	X	X	X
2	8607-013	Terminal Block 2 Pole	X	X		
2	8607-014	Terminal Block 3 Pole			X	X
2	8607-015	Phelon Insulator				X
3	8201-056	Blower Control	X	X	X	
3	8201-032	Blower Relay				X
4	8407-035	Transformer	X	X	X	
4	8407-042	Transformer				X
5	8401-007	Compressor Contactor	X	X		
5	8401-002	Compressor Contactor			X	X
6	8552-050	Compressor Capacitor		X		
6	8552-048	Compressor Capacitor	X			
6	8552-002	Outdoor Motor Capacitor			X	X
8	8611-006	Ground Terminal	X	X	X	X
9	8201-069	Heat Pump Control	X	X	X	X
11	8201-065	Low Pressure Bypass (TDR) (Optional)	X	X	X	X
12	8201-008	Low Ambient Bypass Relay (Optional)	X	X	X	X
13	8607-017	LAC Terminal Block (Optional)	X	X	X	X
14	8551-005	Start Device	X	X		
15	8201-032	Outdoor Fan Relay				X
16	S517-137	Control Panel Top	X	X	X	X
17	135-122	Wire Shield	X	X	X	X
18	117-123	Control Panel	X	X	X	X
NS	4096-110	Wiring Diagram		X		
NS	4096-115	Wiring Diagram	X			
NS	4096-210	Wiring Diagram			X	
NS	4096-310	Wiring Diagram				X

NS Not Shown

# BLOWER ASSEMBLY

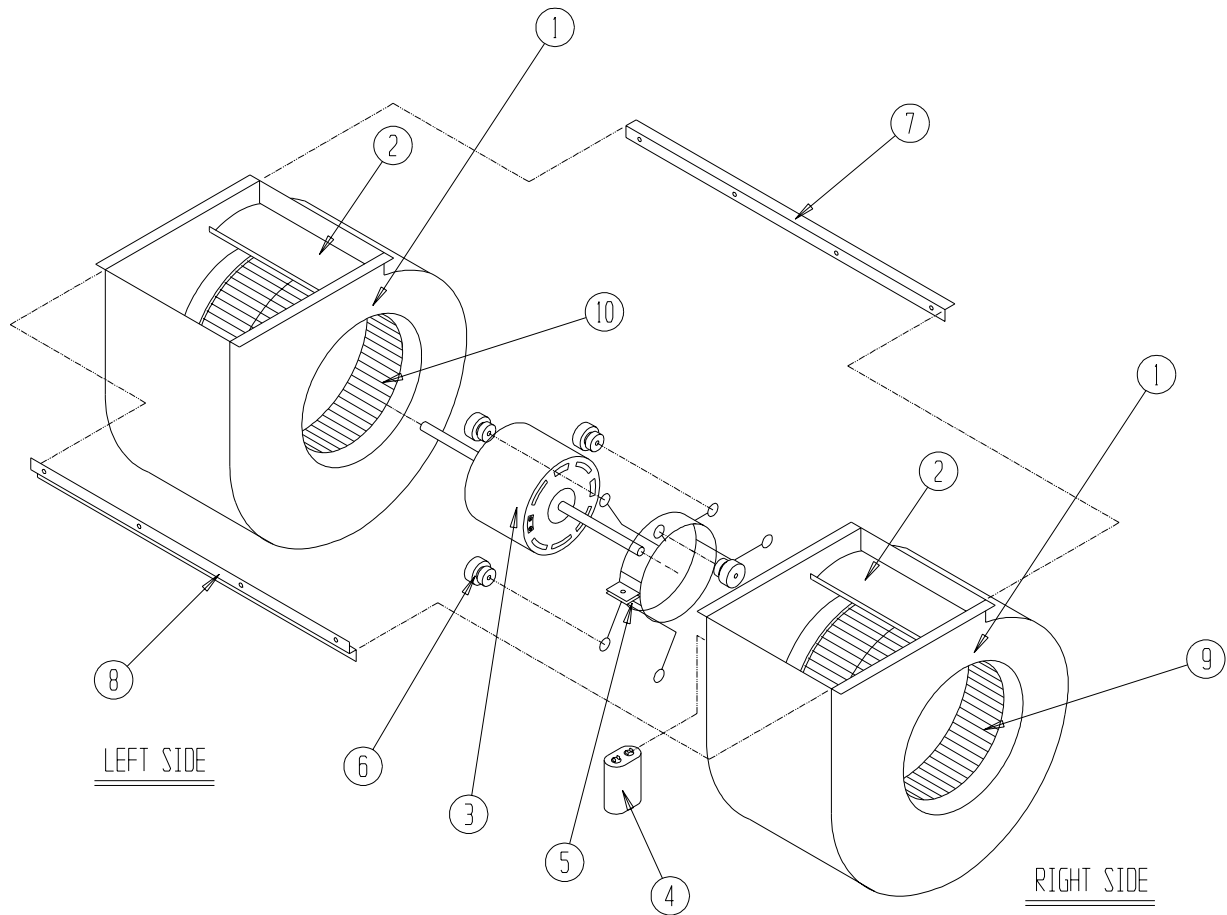

SEXP-346

Drawing No.	Part No.	Description	S900-248	S900-250
1	151-115	Housing	X	X
2	144-183	Cutoff	X	X
3	8102-011	Blower Motor (230/208)	X	
3	8105-033	Blower Motor (460)		X
4	8552-002	Capacitor	X	X
5	8200-031	Motor Mount	X	X
6	5451-011	Grommets	6	6
7	105-1061	Back Brace	X	X
8	103-435	Front Brace	X	X
9	5152-092	Wheel 9-6 CW	X	X
10	5152-093	Wheel 9-6 CCW	X	X