REPLACEMENT PARTS MANUAL

QTEC SERIES PACKAGED HEAT PUMP

Models:

QH244D QH303D
QH363D QH423D
QH483D QH603D

General Notes

- Revised and/or additional pages may be issued from time to time.
- A complete and current manual consists of pages shown in the following contents section.

Contents

Description	Page
Cabinet Components	
♦ Exploded View	1
♦ Usage List	2
♦ Usage List	3
♦ Usage List	4
♦ Usage List	5
♦ Blank Page	6
Functional Components	
♦ Exploded View	7
♦ Usage List	8
♦ Usage List	9
♦ Usage List	10
Upper Control Panel Components	
♦ Exploded View	11
♦ Usage List	12
♦ Usage List	13
♦ Usage List	14
♦ Usage List	15
♦ Usage List	16
♦ Usage List	17
♦ Blank Page	18
Lower Control Panel Components	
♦ Exploded View	19
♦ Usage List	20
Dehumidification Module Components	
♦ Exploded View	21
♦ Usage List	22
Blower Assembly Components	
♦ Exploded View	23
♦ Usage List	24
Optional Climate Control Components	
♦ Exploded View	25
♦ Usage List	26
♦ Climate Control Nomenclature ..	26
Wall Sleeve Cabinet Components	
♦ Exploded View	27
♦ Usage List	28



BARD MANUFACTURING COMPANY
Bryan, Ohio 43506
Since 1914...Moving ahead, just as planned.

Manual: 2110-550C
Supersedes: 2110-550B
File: Tab 14
Date: 06-21-05

CABINET COMPONENTS

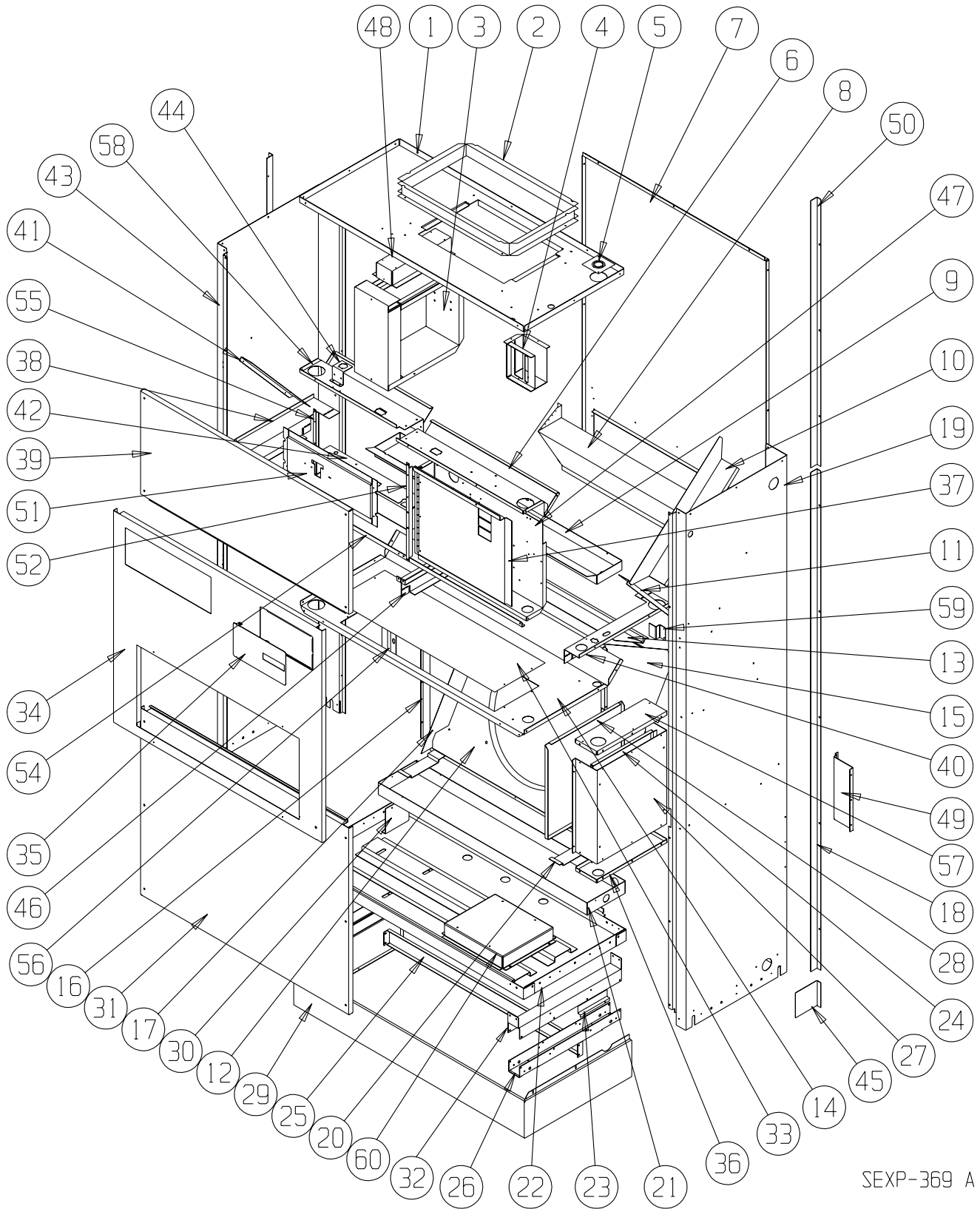

SEXP-369 A

This Exploded View is referenced in Tables on Page 2, 3, 4 & 5

CABINET COMPONENTS

Drawing No.	Part No.	Description	QH244DA, B	QH244DC	QH303DA, B	QH303DC	QH363DA, B	QH363DC	QH423DA, B	QH423DC
1	506-225	Top Assembly	X	X	X	X	X	X	X	X
2	110-044	Outlet Duct Flange	2	2	2	2	2	2	2	2
3	See Page 12	Heater Package Assembly (Optional)	X	X	X	X	X	X	X	X
4	117-187	Low Voltage Box Assembly (Optional)	X	X	X	X	X	X	X	X
5	136-359	T. K.O. Plate	X	X	X	X	X	X	X	X
6	534-191	Evaporator Coil Shield – Right	X	X	X	X	X	X	X	X
7	508-133	Back Assembly	X	X	X	X	X	X	X	X
8	538-106	Fresh Air Damper Assembly	X	X	X	X	X	X	X	X
9	523-104	Evaporator Drain Pan Assembly	X	X	X	X	X	X	X	X
10	134-154	Wire Channel	X	X	X	X	X	X	X	X
11	140X277	Right Evaporator Support	X	X	X	X	X	X	X	X
12	124-032	Fan Shroud Back	X	X	X	X	X	X	X	X
13	142-055	Condenser Coil Fill	X	X	X	X	X	X	X	X
14	520-346	Condenser Partition Assembly	X	X	X	X	X	X	X	X
15	124X043	Fan Shroud Right Side	X	X	X	X	X	X	X	X
16	124Y043	Fan Shroud Left Side	X	X	X	X	X	X	X	X
17	140-229	Condenser Coil Support	2	2	2	2	2	2	2	2
18	135-177-* ①	Side Trim – Lower	2	2	2	2	2	2	2	2
19	500-392-* ①	Right Side Assembly	X	X	X	X	X	X	X	X
20	140-227	Subcooling Loop Hold Down	3	3	3	3	3	3	3	3
21	123-094	Condenser Drain Pan Assembly	X	X	X	X	X	X	X	X
22	527-309-X	Lower Base Assembly	X	X	X	X	X	X	X	X
23	102-415	Pile Seal Offset	2	2	2	2	2	2	2	2
24	117-240	Lower Control Panel Plate	X	X	X	X	X	X	X	X
25	135-189	Base Shield	X	X	X	X	X	X	X	X
26	140-276	Lower Roller Support	2	2	2	2	2	2	2	2
27	See Page 19	Control Panel Components	X	X	X	X	X	X	X	X
28	133-164	Control Panel Door – Lower	X	X	X	X	X	X	X	X
29	534-155-6	Base Trim Assembly	X	X	X	X	X	X	X	X
30	140-230	Drain Pan Support	X	X	X	X	X	X	X	X
31	552-332-* ①	Condenser Door Assembly	X	X	X	X	X	X	X	X
32	140-280	Upper Roller Support	2	2	2	2	2	2	2	2
33	536-351	Condenser Blank Off Plate	X	X	X	X	X	X	X	X
34	552-330-* ①	Filter Door Assembly	X	X	X	X	X	X	X	X
35	152-336-* ①	Circuit Breaker Door	X	X	X	X	X	X	X	X
36	116-238	Lower Control Panel Bottom	X	X	X	X	X	X	X	X
37	132-173	Rotary Disconnect Door Inner		X		X		X		X
37	132-165	Circuit Breaker Door Inner	X		X		X		X	
38	113-281	Left Filter Bracket	X	X	X	X	X	X	X	X
39	552-331-* ①	Blower Door Assembly	X	X	X	X	X	X	X	X

Continued on Page 3

- ① Exterior cabinet parts are manufactured with various color options. To insure that you receive the proper color, you must include the complete models and serial number of the unit for which parts are being ordered.

This Table references Exploded View on Page 1

CABINET COMPONENTS

Drawing No.	Part No.	Description	QH244DA, DB	QH244DC	QH303DA, D B	QH303DC	QH363-D, DB	QH363DC	QH423DA, DB	QH423DC
<i>Continued from Page 2</i>										
40	113-282	Right Filter Bracket	X	X	X	X	X	X	X	X
41	140Y277	Left Evaporator Support	X	X	X	X	X	X	X	X
42	117-243	Relay Control Panel	X	X	X	X	X	X	X	X
43	500-391-* ①	Left Side Assembly	X	X	X	X	X	X	X	X
44	113-142	Expansion Valve Mounting Plate	X	X	X	X	X	X	X	X
45	135-165-* ①	Base Trim Extension	2	2	2	2	2	2	2	2
46	112X283	Center Right Filter Bracket	X	X	X	X	X	X	X	X
46	112Y283	Center Left Filter Bracket	X	X	X	X	X	X	X	X
47	See Page 17	Pull Disconnect Assembly		X		X		X		X
47	See Page 15	Circuit Breaker Box Assembly	X		X		X		X	
48	112-229	Heatstrip Bracket	X	X	X	X	X	X	X	X
49	112-234	Mounting Bracket	2	2	2	2	2	2	2	2
50	135-178-* ①	Side Trim – Upper	2	2	2	2	2	2	2	2
51	See page 26	Thermostat Mounting Plate	X	X	X	X	X	X	X	X
52	104-1096	Left Thermostat Support Angle	X	X	X	X	X	X	X	X
54	104-1097	Front Filter Angle	X	X	X	X	X	X	X	X
55	104-1096	Right Thermostat Support Angle	X	X	X	X	X	X	X	X
56	102-434	Sleeve Offset	X	X	X	X	X	X	X	X
57	117-237	Lower Control Panel Top	X	X	X	X	X	X	X	X
58	534-190	Evaporator Coil Shield – Left	X	X	X	X	X	X	X	X
59	103-443	Door Latch Offset	X	X	X	X	X	X	X	X
60	140-282	Transformer Support		X		X		X		X

- ① Exterior cabinet parts are manufactured with various color options. To insure that you receive the proper color, you must include the complete models and serial number of the unit for which parts are being ordered.

This Table references Exploded View on Page 1

CABINET COMPONENTS

Drawing No.	Part No.	Description	QH483DA, DB	QH603DA, DB
			QH483DC	QH603DC
1	506-226	Top Assembly	X	X
2	110-044	Outlet Duct Flange	2	2
3	See Page 12	Heater Package Assembly (Optional)	X	X
4	117-187	Low Voltage Box Assembly (Optional)	X	X
5	136-359	T. K. O. Plate	X	X
6	534-195	Evaporator Coil Shield – Right	X	X
7	508-149	Back Assembly	X	X
8	538-106	Fresh Air Damper Assembly	X	X
9	523-105	Evaporator Drain Pan Assembly	X	X
10	134-154	Wire Channel	X	X
11	140X277	Right Evaporator Support	X	X
12	124-046	Fan Shroud Back	X	X
13	143-066	Condenser Coil Fill	X	X
14	520-347	Condenser Partition Assembly	X	X
15	124-041	Fan Shroud Right Side	X	X
16	124-045	Fan Shroud Left Side	X	X
17	140-229	Condenser Coil Support	2	2
18	135-177-* ①	Side Trim – Lower	2	2
19	500-392-* ①	Right Side Assembly	X	X
20	140-227	Subcooling Loop Hold Down	3	3
21	123-099	Condenser Drain Pan Assembly	X	X
22	527-294	Lower Base Assembly	X	X
23	102-415	Pile Seal Offset	2	2
24	117-240	Lower Control Panel Plate	X	X
25	134-194	Base Shield	X	X
26	140-276	Lower Roller Support	2	2
27	See Page 7	Control Panel Components	X	X
28	133-164	Control Panel Door – Lower	X	X
29	534-174-6	Base Trim Assembly	X	X
30	140-230	Drain Pan Support	X	X
31	552-334-* ①	Condenser Door Assembly	X	X
32	140-280	Upper Roller Support	2	2
33	536-351	Condenser Blank Off Plate	X	X
34	552-335-* ①	Filter Door Assembly	X	X
35	152-336-* ①	Circuit Breaker Door	X	X
36	116-238	Lower Control Panel Bottom	X	X
37	132-173	Rotary Disconnect Door Inner		X
37	132-165	Circuit Breaker Door Inner	X	
38	113-281	Left Filter Bracket	X	X
39	552-333-* ①	Blower Door Assembly	X	X

Continued on Page 5

- ① Exterior cabinet parts are manufactured with various color options. To insure that you receive the proper color, you must include the complete models and serial number of the unit for which parts are being ordered.

This Table references Exploded View on Page 1

CABINET COMPONENTS

Drawing No.	Part No.	Description	QH483DA, DB QH603DA, DB		QH483DC QH603DC
<i>Continued from Page 4</i>					
40	113-286	Right Filter Bracket	X		X
41	140Y277	Left Evaporator Support	X		X
42	116-243	Relay Control Panel	X		X
43	500-393-* ①	Left Side Assembly	X		X
44	113-142	Expansion Valve Mounting Plate	X		X
45	134-165-* ①	Base Trim Extension	2		2
46	112X283	Center Right Filter Bracket	X		X
46	112Y283	Center Left Filter Bracket	X		X
47	See Page 17	Pull Disconnect Assembly			X
47	See Page 15	Circuit Breaker Box Assembly	X		
48	112-229	Heatstrip Bracket	X		X
49	112-234	Mounting Bracket	2		2
50	135-178-* ①	Side Trim – Upper	2		2
51	See page 26	Thermostat Mounting Plate	X		X
52	104-1096	Left Thermostat Support Angle	X		X
54	104-1101	Front Filter Angle	X		X
55	104-1096	Right Thermostat Support Angle	X		X
56	102-434	Sleeve Offset	X		X
57	117-237	Lower Control Panel Top	X		X
58	534-190	Evaporator Coil Shield – Left	X		X
59	103-443	Door Latch Offset	X		X
60	140-282	Transformer Support			X

- ① Exterior cabinet parts are manufactured with various color options. To insure that you receive the proper color, you must include the complete models and serial number of the unit for which parts are being ordered.

This Table references Exploded View on Page 1

This page has been left blank intentionally.

FUNCTIONAL COMPONENTS

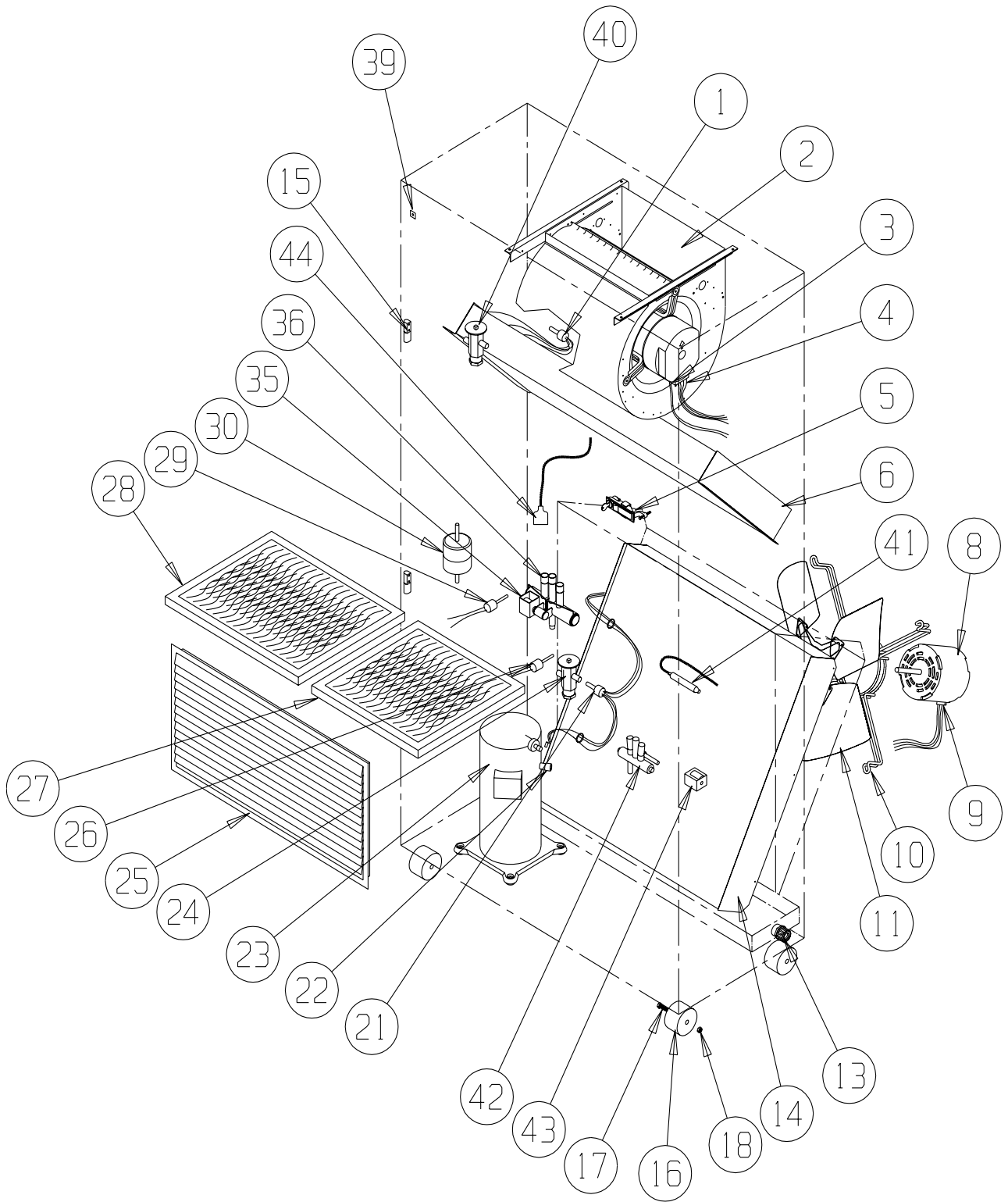

SEXP-376

This Exploded View is referenced in Tables on pages 8, 9 & 10

FUNCTIONAL COMPONENTS

Drawing No.	Part No.	Description	QH244DA	QH244DB	QH244DC	QH303DA	QH303DB	QH303DC	QH363DA	QH363DB	QH363DC	QH423DA	QH423DB	QH423DC
1	5625-015	Distributor Cooling	X	X	X	X	X	X						
1	5625-020	Distributor Cooling							X	X	X	X	X	X
2	900-225-001	Blower Assembly	X	X	X									
2	900-225-002	Blower Assembly				X	X	X						
2	900-225-004	Blower Assembly							X	X	X	X	X	X
3	3000-1145	Wire Harness High Voltage			X			X			X			X
3	3000-1046	Wire Harness High Voltage	X	X		X	X		X	X		X	X	
4	3000-1042	Wire Harness Low Voltage	X	X	X	X	X	X	X	X	X	X	X	X
5	1171-049	Keylatch/Circuit Breaker Door	X	X	X	X	X	X	X	X				
6	917-0039	Evaporator Coil Assembly	X	X	X									
6	917-0104	Evaporator Coil Assembly				X	X	X						
6	917-0040	Evaporator Coil Assembly							X	X	X	X	X	X
8	8103-038	Motor			X			X			X			X
8	8103-037	Motor	X	X		X	X		X	X		X	X	
9	3000-1141	Wire Harness	X	X	X	X	X	X	X	X	X	X	X	X
10	8200-001	Motor Mount	X	X	X	X	X	X	X	X	X	X	X	X
11	5151-050	Fan Blade	X	X	X	X	X	X	X	X	X	X	X	X
13	6094-003	Drain Fitting	1	1	1	1	1	1	1	1	1	1	1	1
14	5051-095	Condenser Coil	X	X	X	X	X	X						
14	5051-096	Condenser Coil							X	X	X	X	X	X
15	5400-005	Hinge	2	2	2	2	2	2	2	2	2	2	2	2
16	1171-035	Wheel	4	4	4	4	4	4	4	4	4	4	4	4
17	1012-129	Bolt - Shoulder	4	4	4	4	4	4	4	4	4	4	4	4
18	1012-224	Nut - Locking	4	4	4	4	4	4	4	4	4	4	4	4
21	5625-008	Distributor - Heating	X	X	X	X	X	X						
21	5625-010	Distributor - Heating							X	X	X	X	X	X
22	910-1257	Defrost Sensor	X	X	X	X	X	X	X	X	X	X	X	X
23	8000-259	Compressor	X											
23	8000-201	Compressor		X										
23	8000-202	Compressor			X									
23	8000-172	Compressor				X								
23	8000-203	Compressor					X							
23	8000-204	Compressor						X						
23	8000-175	Compressor							X					
23	8000-163	Compressor								X				
23	8000-164	Compressor									X			
23	8000-177	Compressor										X		
23	8000-205	Compressor											X	
23	8000-206	Compressor												X
24	5651-137	TXV Heating	X	X	X									
24	5651-138	TXV Heating				X	X	X						
24	5651-102	TXV Heating							X	X	X	X	X	X
25	7051-034	Return Air Grille	X	X	X	X	X	X	X	X	X	X	X	X
26	1804-0106	High Pressure Control	X	X	X	X	X	X	X	X	X	X	X	X
27	7004-009	Air Filter	X	X	X	X	X	X	X	X	X	X	X	X
27	7004-032	Filter 2" Fiberglass (Optional)	X	X	X	X	X	X	X	X	X	X	X	X
27	7004-034	Filter 2" Pleated (Optional)	X	X	X	X	X	X	X	X	X	X	X	X
28	7004-010	Air Filter	X	X	X	X	X	X	X	X	X	X	X	X
28	7004-033	Filter 2" Fiberglass (Optional)	X	X	X	X	X	X	X	X	X	X	X	X
28	7004-035	Filter 2" Pleated (Optional)	X	X	X	X	X	X	X	X	X	X	X	X

Continued on Page 9

This Table references Exploded View on Page 7

FUNCTIONAL COMPONENTS

Drawing No.	Part No.	Description	QH244DA	QH244DB	QH244DC	QH303DA	QH303DB	QH303DC	QH363DA	QH363DB	QH363DC	QH423DA	QH423DB	QH423DC
			<i>Continued from page 8</i>											
29	CMA-26	Low Pressure Control	X	X	X	X	X	X	X	X	X	X	X	X
30	5201-009	Filter / Drier	X	X	X	X	X	X	X	X	X	X	X	X
35	5650-038	Reversing Valve	X	X	X									
35	5650-039	Reversing Valve				X	X	X						
35	5650-041	Reversing Valve							X	X	X	X	X	X
36	5650-042	Rev. Valve Solenoid, Red Casing (Ranco)	X	X	X	X	X	X	X	X	X	X	X	X
36	5650-043	Rev. Valve Solenoid, Blk Casing (Wilspec)	X	X	X	X	X	X	X	X	X	X	X	X
39	1012-315	"U" Clip Fastener	10	10	10	10	10	10	10	10	10	10	10	10
40	5651-137	TXV Cooling	X	X	X									
40	5651-138	TXV Cooling				X	X	X						
40	5651-102	TXV Cooling							X	X	X	X	X	X
42	5650-036	Three Way Valve	X	X	X	X	X	X	X	X	X	X	X	X
43	5650-043	Three Way Valve Solenoid	X	X	X	X	X	X	X	X	X	X	X	X
44	5650-037	Molded Plug 36" Lead	X	X	X	X	X	X	X	X	X	X	X	X
NS	1804-0108	Low Ambient Control	X	X	X	X	X	X	X	X	X	X	X	X
NS	4100-114	Wiring Diagram	X			X			X			X		
NS	4100-214	Wiring Diagram		X			X			X			X	
NS	4100-314	Wiring Diagram			X			X			X			X

NS = Not Shown

These Tables reference Exploded View on Page 7

FUNCTIONAL COMPONENTS

Drawing			QH483DA	QH483DB	QH483DC	QH603DA	QH603DB	QH603DC
No.	Part No.	Description						
1	5625-022	Cooling Distributor	X	X	X			
1	5625-019	Cooling Distributor				X	X	X
2	900-225-005	Blower Assembly	X	X	X			
2	900-254-001	Blower Assembly				X	X	X
3	3000-1145	Wire Harness High Voltage			X			X
3	3000-1046	Wire Harness High Voltage	X	X		X	X	
4	3000-1042	Wire Harness Low Voltage	X	X	X	X	X	X
5	1171-049	Keylatch/Circuit Breaker Door	X	X	X	X	X	X
6	917-0041	Evaporator Coil	X	X	X			
6	917-0069	Evaporator Coil				X	X	X
8	8103-038	Motor			X			X
8	8103-037	Motor	X	X		X	X	
9	3000-1141	Wire Harness	X	X	X	X	X	X
10	8200-001	Motor Mount	X	X	X	X	X	X
11	5151-050	Fan Blade	X	X	X	X	X	X
13	6094-003	Drain Fitting	2	2	2	2	2	2
14	5051-104	Condenser Coil	X	X	X	X	X	X
15	5400-005	Hinge	2	2	2	2	2	2
16	1171-035	Wheel	4	4	4	4	4	4
17	1012-129	Bolt - Shoulder	4	4	4	4	4	4
18	1012-224	Nut - Locking	4	4	4	4	4	4
21	5625-007	Distributor - Heating	X	X	X	X	X	X
22	910-1257	Defrost Sensor	X	X	X	X	X	X
23	8000-150	Compressor	X					
23	8000-248	Compressor		X				
23	8000-248	Compressor			X			
23	8000-150	Compressor				X		
23	8000-162	Compressor					X	
23	8000-248	Compressor						X
24	5651-103	TXV Heating	X	X	X			
24	5651-163	TXV Heating				X	X	X
25	7051-039	Return Air Grille	X	X	X	X	X	X
26	1804-0106	High Pressure Control	X	X	X	X	X	X
27	7004-009	Air Filter	X	X	X	X	X	X
27	7004-032	Filter 2" Fiberglass (Optional)	X	X	X	X	X	X
27	7004-034	Filter 2" Pleated (Optional)	X	X	X	X	X	X
28	7004-011	Air Filter	X	X	X	X	X	X
28	7004-036	Filter 2" Fiberglass (Optional)	X	X	X	X	X	X
28	7004-037	Filter 2" Pleated (Optional)	X	X	X	X	X	X
29	CMA-26	Low Pressure Control	X	X	X	X	X	X
30	5201-009	Filter / Drier	X	X	X	X	X	X
35	5650-041	Reversing Valve	X	X	X	X	X	X
36	5650-042	Rev. Valve Solenoid, Red Casing (Ranco)						
36	5650-043	Rev. Valve Solenoid, Black Casing (Wilspec)	X	X	X	X	X	X
39	1012-315	"U" Clip Fastener	10	10	10	10	10	10
40	5651-103	TXV Cooling	X	X	X			
40	5651-163	TXV Cooling				X	X	X
42	5650-036	Three Way Valve	X	X	X	X	X	X
43	5650-043	Three Way Valve Solenoid	X	X	X	X	X	X
44	5650-037	Molded Plug 3/8" Lead	X	X	X	X	X	X
NS	1804-0108	Low Ambient Control	X	X	X	X	X	X
NS	4100-114	Wiring Diagram	X			X		
NS	4100-214	Wiring Diagram		X			X	
NS	4100-314	Wiring Diagram			X			X

NS = Not Shown

These Tables reference Exploded View on Page 7

UPPER CONTROL PANEL COMPONENTS

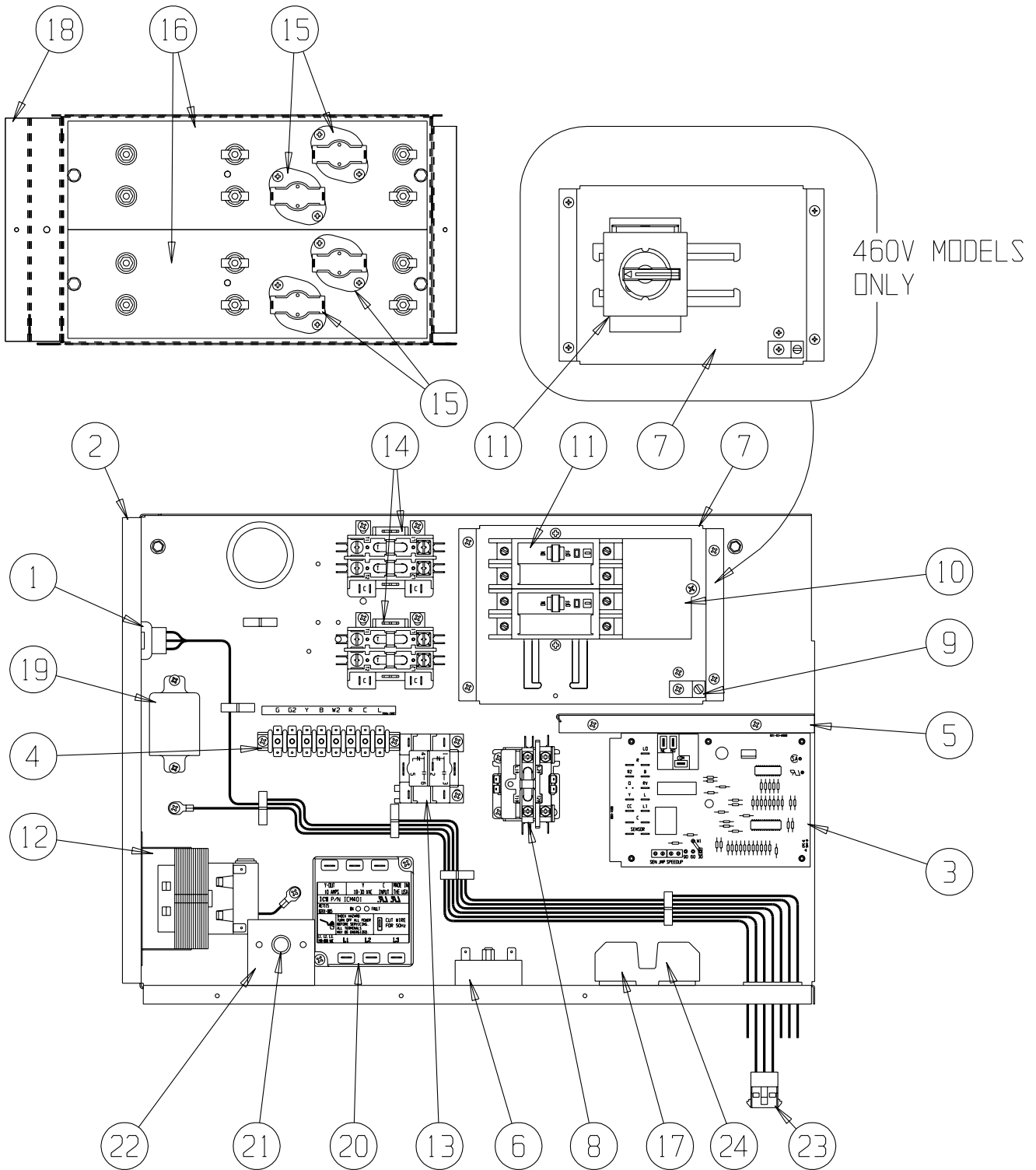

SEXP-373 A

This Exploded View is referenced in Tables on pages 12 thru 17

UPPER CONTROL PANEL COMPONENTS

Drawing No.	Part No.	Description	QH244DA0Z	QH303DA0Z	QH363DA0Z	QH423DA0Z	QH483DA0Z	QH603DA0Z	QH244DA05	QH303DA05	QH363DA05	QH423DA05	QH483DA05	QH603DA05
1	3000-1149	Wire Set PL2	X	X	X	X	X	X	X	X	X	X	X	X
2	117-241	Control Panel	X	X	X	X	X	X	X	X	X	X	X	X
3	8201-101	Heat Pump Control	X	X	X	X	X	X	X	X	X	X	X	X
4	8607-022	Terminal Block	X	X	X	X	X	X	X	X	X	X	X	X
5	117-242	Box Partition	X	X	X	X	X	X	X	X	X	X	X	X
6	8201-078	Low Pressure TDR	X	X	X	X	X	X	X	X	X	X	X	X
7	126-267	Circuit Breaker Base	X	X	X	X	X	X	X	X	X	X	X	X
8	8401-007	Contactor	X	X	X				X	X				
8	8401-016	Contactor					X	X					X	X
9	8611-006	Ground Lug	X	X	X	X	X	X	X	X	X	X	X	X
10	8615-047	Jumper Bar Base											X	X
11	8615-036	Circuit Breaker 2 Pole 25A Ckt B											X	X
11	8615-037	Circuit Breaker 2 Pole 30A Ckt A	X											
11	8615-039	Circuit Breaker 2 Pole 45A Ckt A		X										
11	8615-040	Circuit Breaker 2 Pole 50A Ckt A			X	X			X				X	
11	8615-041	Circuit Breaker 2 Pole 60A Ckt A						X			X			X
12	8407-048	Transformer	X	X	X	X	X	X	X	X	X	X	X	X
14	8401-006	Contactor 2 Pole 20A							X	X	X	X	X	X
15	8402-100	Limits							1	1	1			
15	8402-131	Limits												X
16	8601-103	Heat Strip 5kW							X	X	X	X	X	X
18	118-191	Heat Strip Wrapper							X	X	X	X	X	X
19	8201-048	Relay							X	X	X	X	X	X
21	8611-094	Indicator Light	X	X	X	X	X	X	X	X	X	X	X	X
22	112-225	Bracket	X	X	X	X	X	X	X	X	X	X	X	X
23	3000-1148	Wire Set PL3	X	X	X	X	X	X	X	X	X	X	X	X
NS	132-145	Heat Strip Cover							X	X	X	X	X	X
NS	4101-100	Wiring Diagram	X	X	X	X	X							
NS	4101-101	Wiring Diagram							X	X				
NS	4101-106	Wiring Diagram											X	X

NS = Not Shown

This Table references Exploded View on Page 11

UPPER CONTROL PANEL COMPONENTS

Drawing No.	Part No.	Description	QH244DA10	QH303DA10	QH363DA10	QH423DA10	QH483DA10	QH603DA10	QH363DA15	QH423DA15	QH483DA15	QH603DA15
1	3000-1149	Wire Set PL2	X	X	X	X	X	X	X	X	X	X
2	117-241	Control Panel	X	X	X	X	X	X	X	X	X	X
3	8201-101	Heat Pump Control	X	X	X	X	X	X	X	X	X	X
4	8607-022	Terminal Block	X	X	X	X	X	X	X	X	X	X
5	117-242	Box Partition	X	X	X	X	X	X	X	X	X	X
6	8201-078	Low Pressure TDR	X	X	X	X	X	X	X	X	X	X
7	126-267	Circuit Breaker Base	X	X	X	X	X	X	X	X	X	X
8	8401-007	Contactor	X	X					X			
8	8401-016	Contactor					X	X			X	X
9	8611-006	Ground Lug	X	X	X	X	X	X	X	X	X	X
10	8615-047	Jumper Bar Base	X	X	X	X	X	X	X	X	X	X
11	8615-037	Circuit Breaker 2 Pole 30A Ckt A	X									
11	8615-055	Circuit Breaker 2 Pole 40A Ckt A		X					X		X	
11	8615-040	Circuit Breaker 2 Pole 50A Ckt A			X					X		
11	8615-040	Circuit Breaker 2 Pole 50A Ckt B	X	X	X	X	X	X	X			X
11	8615-041	Circuit Breaker 2 Pole 60A Ckt A					X					X
12	8407-048	Transformer	X	X	X	X	X	X	X	X	X	X
14	8401-006	Contactor 2 Pole 20A	X	X	X	X	X	X	2	2	2	2
15	8402-100	Limits	2	2	2				3	3		
15	8402-131	Limits						2				3
16	8601-103	Heat Strip 5 kW							X	X	X	X
16	8601-104	Heat Strip 10 kW	X	X	X	X	X	X	X	X	X	X
18	118-191	Heat Strip Wrapper	X	X	X	X	X	X	X	X	X	X
19	8201-048	Relay	X	X	X	X	X	X	X	X	X	X
21	8611-094	Indicator Light	X	X	X	X	X	X	X	X	X	X
22	112-225	Bracket	X	X	X	X	X	X	X	X	X	X
23	3000-1148	Wire Set PL3	X	X	X	X	X	X	X	X	X	X
NS	132-145	Heat Strip Cover	X	X	X	X	X	X	X	X	X	X
NS	4101-102	Wiring Diagram	X	X	X	X	X					
NS	4101-103	Wiring Diagram							X	X	X	X

NS = Not Shown

This Table references Exploded View on Page 11

UPPER CONTROL PANEL COMPONENTS

Drawing No.	Part No.	Description	QH244DB0Z	QH303DB0Z	QH363DB0Z	QH423DB0Z	QH483DB0Z	QH603DB0Z	QH243DB06	QH303DB06	QH363DB06	QH423DB06	QH483DB06
1	3000-1149	Wire Set PL2	X	X	X	X	X	X	X	X	X	X	X
2	117-241	Control Panel	X	X	X	X	X	X	X	X	X	X	X
3	8201-101	Heat Pump Control	X	X	X	X	X	X	X	X	X	X	X
4	8607-022	Terminal Block	X	X	X	X	X	X	X	X	X	X	X
5	117-242	Box Partition	X	X	X	X	X	X	X	X	X	X	X
6	8201-078	Low Pressure TDR	X	X	X	X	X	X	X	X	X	X	X
7	126-267	Circuit Breaker Base	X	X	X	X	X	X	X	X	X	X	X
8	8401-002	Contactor	X	X	X	X	X	X	X	X	X	X	X
9	8611-006	Ground Lug	X	X	X	X	X	X	X	X	X	X	X
11	8615-054	Circuit Breaker 3 Pole 20A	X										
11	8615-051	Circuit Breaker 3 Pole 25A		X									
11	8615-052	Circuit Breaker 3 Pole 30A			X								
11	8615-042	Circuit Breaker 3 Pole 35A				X			X				
11	8615-043	Circuit Breaker 3 Pole 40A								X			
11	8615-044	Circuit Breaker 3 Pole 45A						X				X	
12	8407-048	Transformer	X	X	X	X	X	X	X	X	X	X	X
14	8401-006	Contactor 2 Pole 20A							X	X	X	X	X
15	8402-100	Limits							2	2	2	2	2
16	8601-105	Heat Strip 6 kW							X	X	X	X	X
18	118-191	Heat Strip Wrapper							X	X	X	X	X
19	8201-048	Relay							X	X	X	X	X
21	8611-094	Indicator Light	X	X	X	X	X	X	X	X	X	X	X
22	112-225	Bracket	X	X	X	X	X	X	X	X	X	X	X
23	3000-1148	Wire Set PL3	X	X	X	X	X	X	X	X	X	X	X
NS	132-145	Heat Strip Cover							X	X	X	X	X
NS	4101-200	Wiring Diagram	X	X	X	X	X	X					
NS	4101-201	Wiring Diagram							X	X	X	X	X

NS = Not Shown

This Table references Exploded View on Page 11

UPPER CONTROL PANEL COMPONENTS

Drawing No.	Part No.	Description	QH244DB09	QH303DB09	QH363DB09	QH423DB09	QH483DB09	QH603DB09	QH303DB12	QH363DB15	QH423DB15	QH483DB15	QH603DB15
1	3000-1149	Wire Set PL2	X	X	X	X	X	X	X	X	X	X	X
2	117-241	Control Panel	X	X	X	X	X	X	X	X	X	X	X
3	8201-101	Heat Pump Control	X	X	X	X	X	X	X	X	X	X	X
4	8607-022	Terminal Block	X	X	X	X	X	X	X	X	X	X	X
5	117-242	Box Partition	X	X	X	X	X	X	X	X	X	X	X
6	8201-078	Low Pressure TDR	X	X	X	X	X	X	X	X	X	X	X
7	126-267	Circuit Breaker Base	X	X	X	X	X	X	X	X	X	X	X
8	8401-002	Contactors	X	X	X	X	X	X	X	X	X	X	X
9	8611-006	Ground Lug	X	X	X	X	X	X	X	X	X	X	X
11	8615-044	Circuit Breaker 3 Pole 45A	X										
11	8615-045	Circuit Breaker 3 Pole 50A		X									
11	8615-046	Circuit Breaker 3 Pole 60A			X	X	X	X	X	X	X	X	X
12	8407-048	Transformer	X	X	X	X	X	X	X	X	X	X	X
14	8401-006	Contactors 2 Pole 20A	X	X	X	X	X	X	X	2	2	2	X
15	8402-100	Limits	2	2	2			4	4				
15	8402-131	Limits					2						4
16	8601-105	Heat Strip 6 kW						2	X	X	X	X	X
16	8604-106	Heat Strip 9 kW	X	X	X	X	X		X	X	X	X	X
18	118-191	Heat Strip Wrapper	X	X	X	X	X	X	X	X	X	X	X
19	8201-048	Relay	X	X	X	X	X	X	X	X	X	X	X
21	8611-094	Indicator Light	X	X	X	X	X	X	X	X	X	X	X
22	112-225	Bracket	X	X	X	X	X	X	X	X	X	X	X
23	3000-1148	Wire Set PL3	X	X	X	X	X	X	X	X	X	X	X
NS	132-145	Heat Strip Cover	X	X	X	X	X	X	X	X	X	X	X
NS	4101-201	Wiring Diagram	X	X	X	X							
NS	4101-202	Wiring Diagram								X	X		
NS	4101-203	Wiring Diagram						X					

NS = Not Shown

This Table references Exploded View on Page 11

UPPER CONTROL PANEL COMPONENTS

Drawing No.	Part No.	Description	QH244DC0Z	QH303DC0Z	QH363DC0Z	QH423DC0Z	QH483DC0Z	QH603DC0Z	QH244DC06	QH303DC06	QH363DC06	QH423DC06	QH483DC06
1	3000-1149	Wire Set PL2	X					X			X		
2	117-241	Control Panel	X					X			X		
3	8201-101	Heat Pump Control	X					X			X		
4	8607-022	Terminal Block	X					X			X		
5	117-242	Box Partition	X					X			X		
6	8201-078	Low Pressure TDR	X					X			X		
7	126-323	Rotary Disconnect Base	X					X			X		
8	8401-002	Contactator	X					X			X		
9	8611-006	Ground Lug	X					X			X		
11	8615-068	Disconnect	X					X			X		
12	8407-050	Transformer	X					X			X		
13	8201-009	Relay OMR	X					X			X		
14	8401-002	Contactator 3 Pole 25A	X					X			X		
15	8402-100	Limits										2	
16	8604-107	Heat Strip 6 kW 480V										X	
17	8614-041	Fuse Holder	X					X			X		
18	118-191	Heat Strip Wrapper										X	
19	8201-048	Relay										X	
20	8201-085	Phase Monitor	X					X			X		
21	8611-094	Indicator Light	X					X			X		
22	112-225	Bracket	X					X			X		
23	3000-1148	Wire Set PL3	X					X			X		
NS	8407-052	Transformer Stepdown 1.0 KVA	X									X	
NS	8407-053	Transformer Stepdown 1.5 KVA	X					X			X		
NS	8407-054	Transformer Stepdown 2.0 KVA						X					
NS	8614-046	Fuses Class CC 5.0A ①			2			2				2	
NS	8614-047	Fuses Class CC 3.2A ②			2							2	
NS	8614-042	Fuses Class CC 7.0A ③						2					
NS	132-145	Heat Strip Cover										X	
NS	8615-071	Pull Disconnect Handle	X					X			X		
NS	4101-300	Wiring Diagram	X					X					
NS	4101-301	Wiring Diagram										X	

NS = Not Shown

① 5.0 Amp fuses used with 1.5 KVA transformer.

② 3.2 Amp fuses used with 1 KVA transformer.

③ 7.0 Amp fuses used with 2 KVA transformer

This Table references Exploded View on Page 11

UPPER CONTROL PANEL COMPONENTS

Drawing No.	Part No.	Description	QH244DC09	QH303DC09	QH363DC09	QH423DC09	QH483DC09	QH603DC09	QH303DC12	QH363DC15	QH423DC15	QH483DC15	QH603DC15
1	3000-1149	Wire Set PL2		X				X	X	X			X
2	117-241	Control Panel		X				X	X	X			X
3	8201-101	Heat Pump Control		X				X	X	X			X
4	8607-022	Terminal Block		X				X	X	X			X
5	117-242	Box Partition		X				X	X	X			X
6	8201-078	Low Pressure TDR		X				X	X	X			X
7	126-323	Rotary Disconnect Base		X				X	X	X			X
8	8401-002	Contactors		X				X	X	X			X
9	8611-006	Ground Lug		X				X	X	X			X
11	8615-068	Rotary Disconnect		X				X	X	X			X
12	8407-050	Transformer		X				X	X	X			X
13	8201-009	Relay OMR		X				X	X	X			X
14	8401-002	Contactors 3 Pole 25A		X				X	X	X	2		X
15	8402-100	Limits	2						4		4		
15	8402-131	Limits						2					4
16	8604-107	Heat Strip 6 kW 480V							2	X			X
16	8604-108	Heat Strip 9 kW 480V	X					X					
17	8614-041	Fuse Holder	X					X	X	X			X
18	118-191	Heat Strip Wrapper	X					X	X	X			X
19	8201-048	Relay	X					X	X	X			X
20	8201-085	Phase Monitor	X					X	X	X			X
21	8611-094	Indicator Light	X					X	X	X			X
22	112-225	Bracket	X					X	X	X			X
23	3000-1148	Wire Set PL3	X					X	X	X			X
NS	8407-052	Transformer Stepdown 1.0 KVA	X						X	X			
NS	8407-053	Transformer Stepdown 1.5 KVA	X					X	X	X			X
NS	8407-054	Transformer Stepdown 2.0 KVA						X					X
NS	8614-046	Fuses Class CC 5.0A ①	2					2	2	2	2		2
NS	8614-047	Fuses Class CC 3.2A ②	2						2		2		
NS	8614-042	Fuses Class CC 7.0A ③						2					2
NS	132-145	Heat Strip Cover	X					X	X	X			X
NS	8615-071	Rotary Disconnect Handle	X					X	X	X			X
NS	4101-301	Wiring Diagram	X					X					
NS	4101-302	Wiring Diagram								X			X
NS	4101-303	Wiring Diagram							X				

This Table references Exploded View on Page 11

This page has been left blank intentionally.

LOWER CONTROL PANEL COMPONENTS

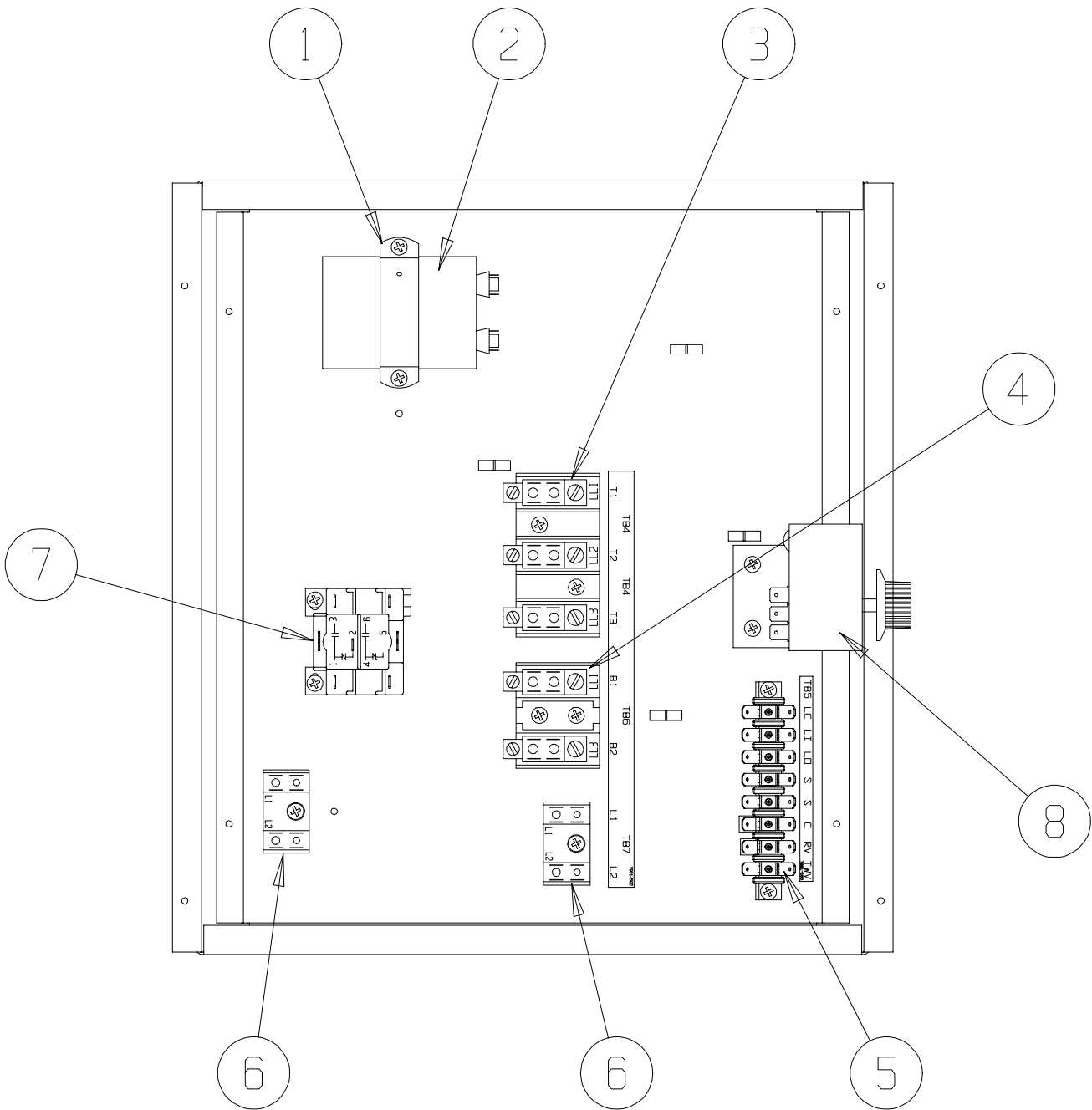

SEXP-374

LOWER CONTROL PANEL COMPONENTS

Drawing			QH244DA	QH303DA	QH363DA	QH423DA	QH483DA	QH603DA	QH244DB	QH303DB	QH363DB	QH423DB	QH483DB	QH603DB	QH244DC	QH303DC	QH363DC	QH423DC	QH483DC	QH603DC
No.	Part No.	Description																		
1	8552-008	Capacitor Strap	X	X	X	X	X													
1	8552-003	Capacitor Strap								X								X		
2	8552-002	Fan Capacitor								X								X		
2	8552-050	Compressor Capacitor	X																	
2	8552-052	Compressor Capacitor		X																
2	8552-063	Compressor Capacitor			X															
2	8552-062	Compressor Capacitor				X														
2	8552-076	Compressor Capacitor						X												
3	8607-014	Terminal Block 3 Ter								X								X		
4	8607-013	Terminal Block 2 Ter	X	X	X	X	X	X											X	
5	8607-022	Terminal Block 8 Pos	X	X	X	X	X	X		X									X	
6	8607-017	Terminal Block 2 Ter	X	X	X	X	X	X		X									X	
7	8201-032	Low Ambient Bypass Relay (Opt)	X	X	X	X	X	X		X									X	
8	8408-034	Outdoor Thermostat ①	X	X	X	X	X	X		X									X	

① Optional on standard models. Standard on low ampacity models.

DEHUMIDIFICATION MODULE COMPONENTS

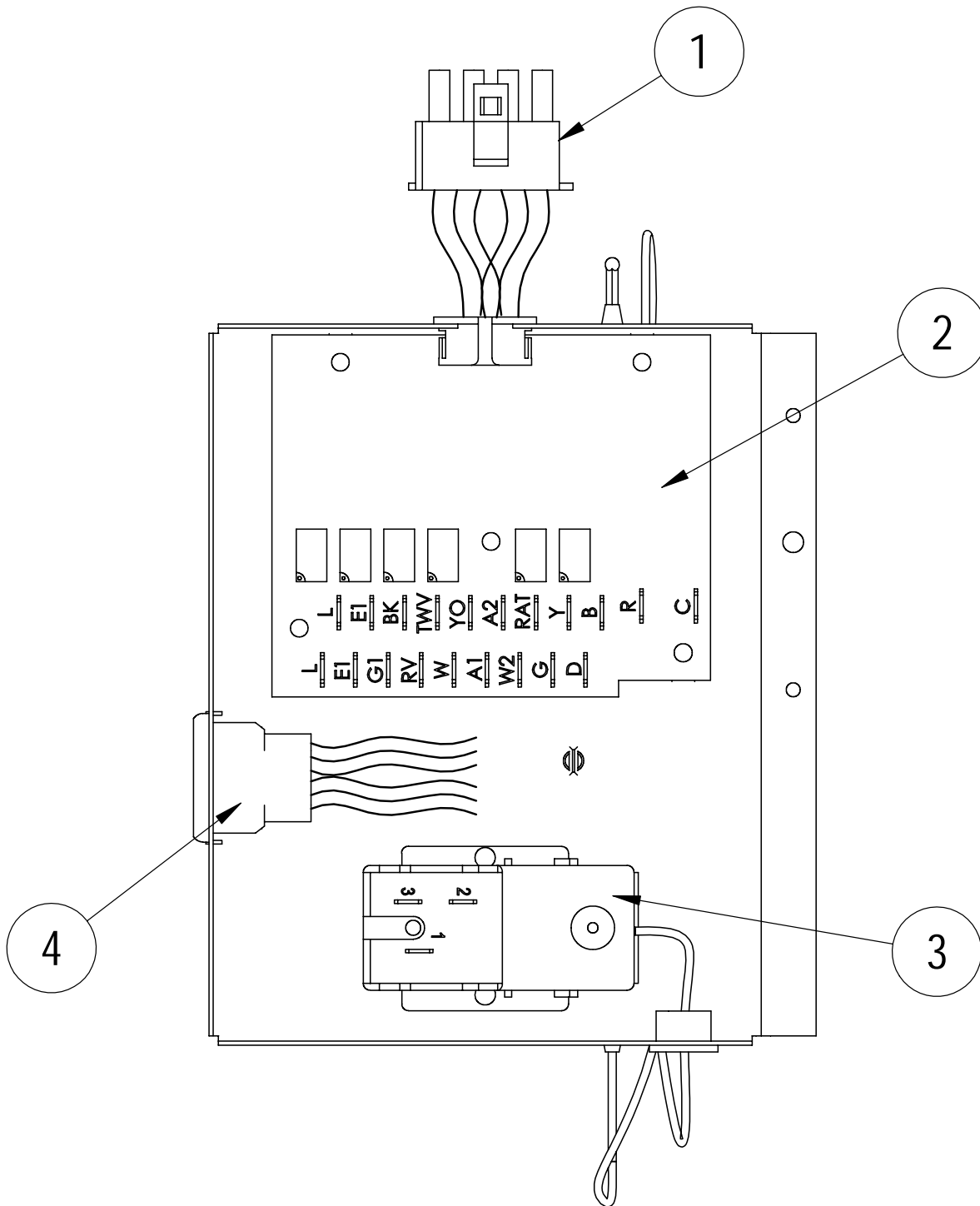

SEXP-418

DEHUMIDIFICATION MODULE COMPONENTS

Drawing No.	Part No.	Description	Options X, E, G, F
1	3000-1196	Wire Harness Male	X
2	8201-092	Logic Board	X
3	8408-037	Return Air Thermostat	X
4	3000-1197	Wire Harness Female	X

BLOWER ASSEMBLY COMPONENTS

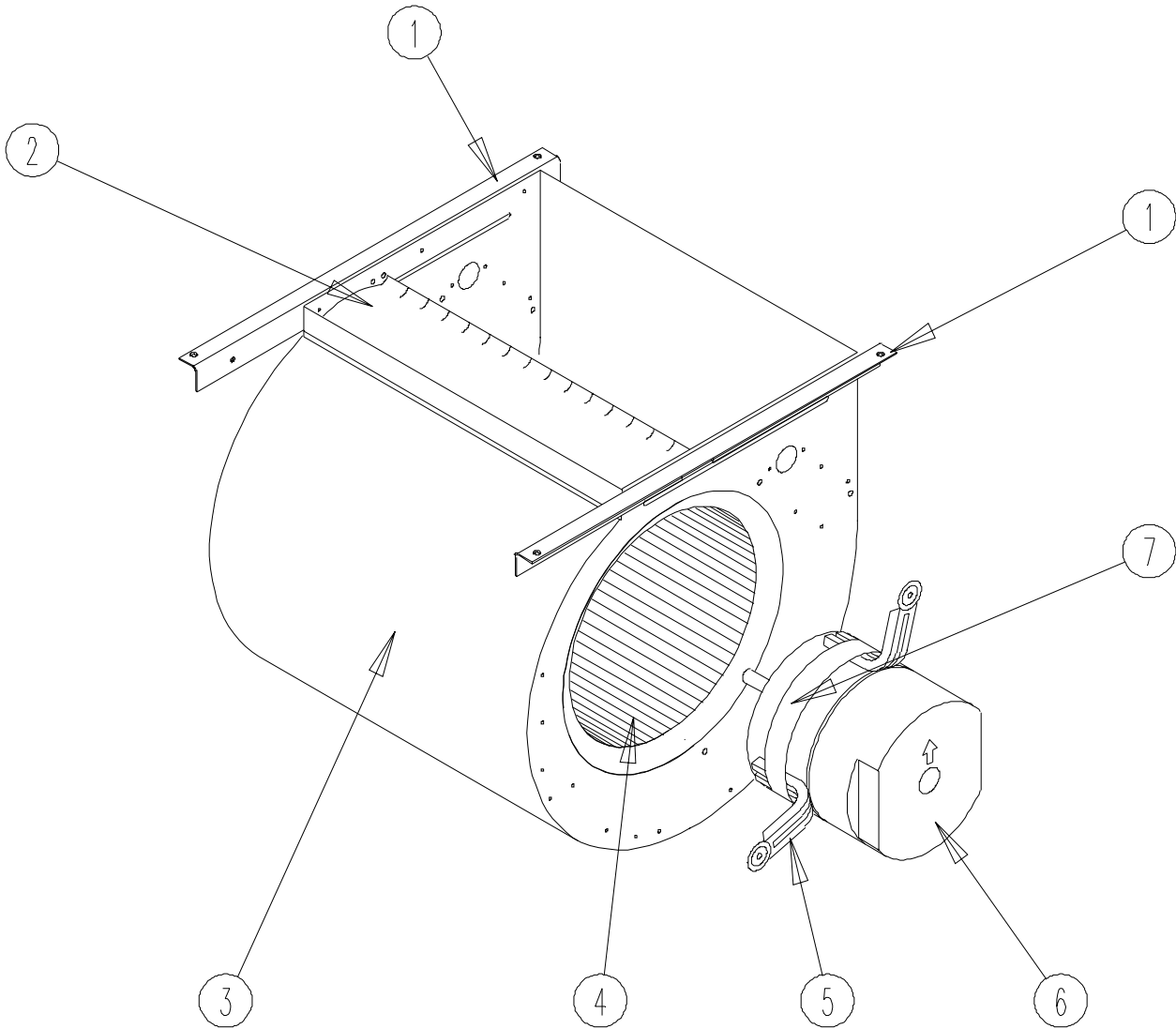

SEXP-245

BLOWER ASSEMBLY COMPONENTS

Drawing No.	Part No.	Description	900-255-001	900-225-002	900-225-004	900-225-005	900-254-001
1	104-980	Blower Angle	2	2	2	2	2
2	144-131	Diffuser	X	X	X	X	X
3	151-110	Blower Housing	X	X	X	X	X
4	5152-061	Blower Wheel	X	X	X	X	X
5	8200-034	Motor Mount Arm	3	3	3	3	3
6	8106-035-0003	Motor	X				
6	8106-035-0004	Motor		X			
6	8106-035-0005A	Motor			X		
6	8106-035-0013	Motor				X	
6	8107-009-0024	Motor					X
7	8200-033	Motor Mount Band	X	X	X	X	X

OPTIONAL CLIMATE CONTROLS

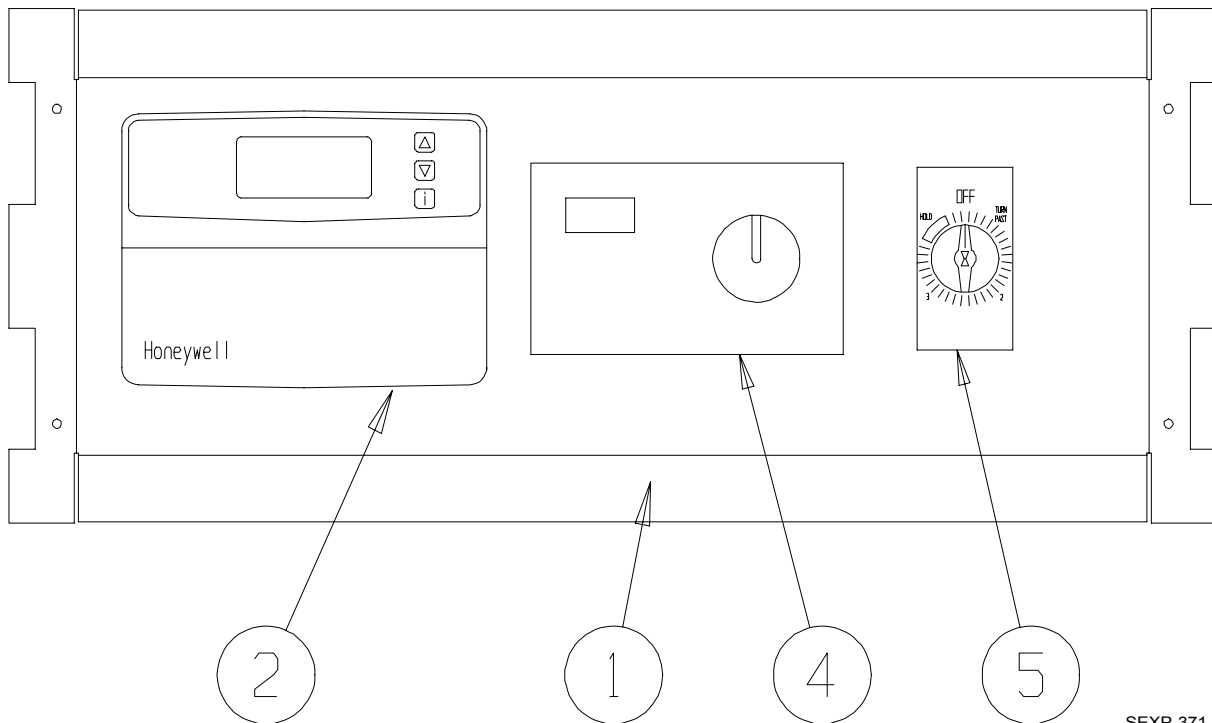
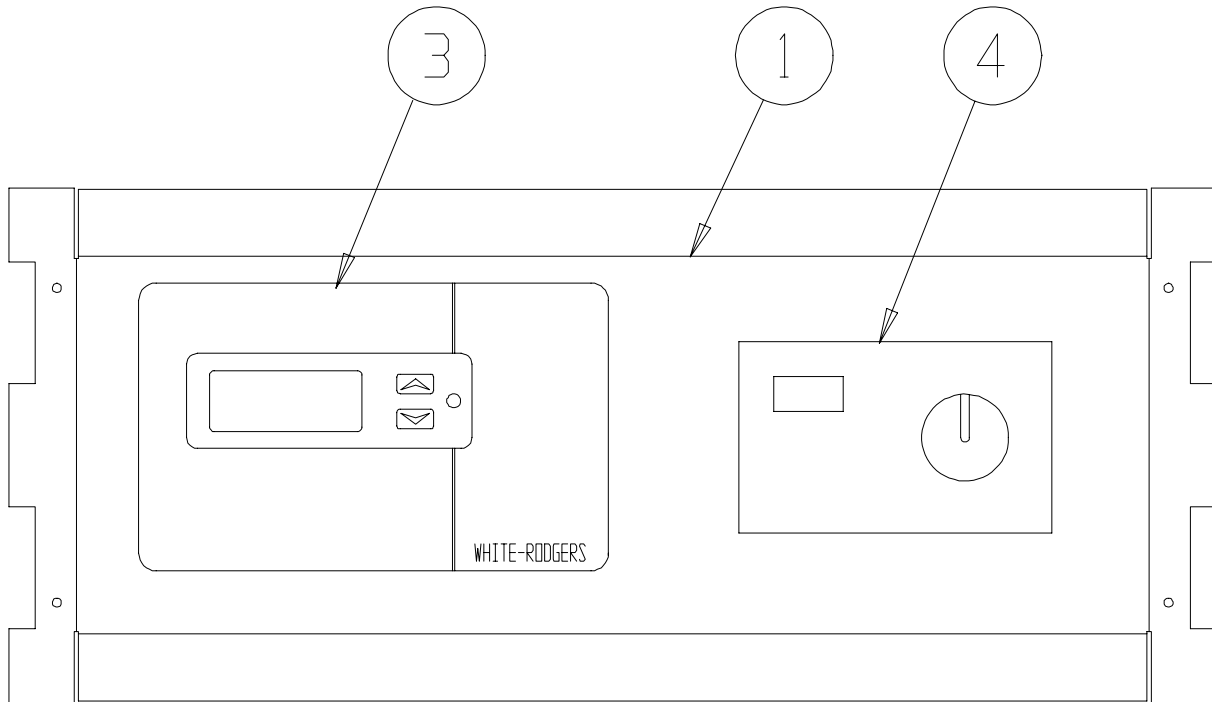

SEXP-371

OPTIONAL CLIMATE CONTROLS

Drawing No.	Part No.	Description	QH243, QH302 QH362, QH422				QH482 QH602				
			Option X	Option E	Option F	Option G	Option X	Option E	Option F	Option G	
1	S127-313-* ①	Thermostat Plate	X				X				
1	S127-314-* ①	Thermostat Plate		X		X		X			X
1	S127-312-* ①	Thermostat Plate			X				X		
2	8403-042	Electronic, Non-prgrammable, Manual/Auto Change Over			X	X				X	X
3	8403-049	Electronic, Prgrammable, Manual/Auto Change Over		X				X			
4	8403-047	Humidistat		X	X	X		X	X	X	
5	8612-015	Timer			X					X	
NS	3000-1151	Wire Harness, Low Voltage Terminal Strip to PL2	X				X				
NS	3000-1152	Wire Harness, Thermostat to PL2		X				X			
NS	3000-1150	Wire Harness, Thermostat to PL2			X				X		
NS	3000-1160	Wire Harness, Thermostat to PL2				X					X
NS	8607-019	Low Voltage Terminal Strip	X			X	X				X
NS	8607-021	Low Voltage Terminal Strip 8 Terminal	X				X				
NS	4102-036	Wiring Diagram	X				X				
NS	4102-037	Wiring Diagram		X				X			
NS	4102-038	Wiring Diagram			X				X		
NS	4102-039	Wiring Diagram				X					X

① Exterior cabinet parts are manufactured with various color options. To insure that you receive the proper color, you must include the complete models and serial number of the unit for which parts are being ordered.

NS Not Shown

CLIMATE CONTROL OPTION NOMENCLATURE AS SHOWN IN UNIT MODEL NUMBER

QH 363 D A 09 X X X X X X

- X – None
- E – Electronic, programmable, manual/auto change over
- F – Electronic, non-programmable, manual/auto change over with timer and humidistat
- G – Electronic, non-programmable, manual/auto change over with humidistat

WALL SLEEVE CABINET COMPONENTS

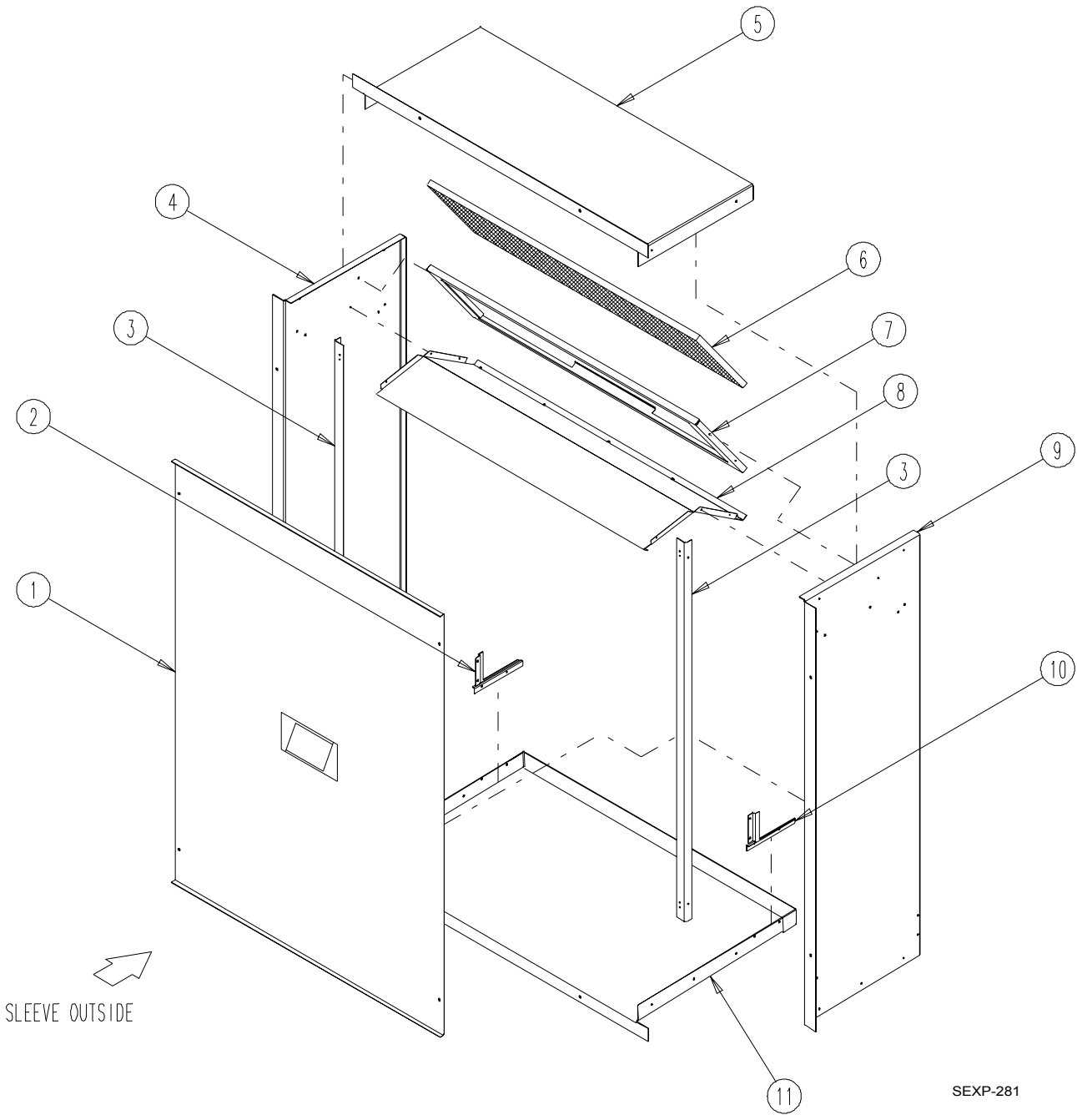

WALL SLEEVE CABINET COMPONENTS

Drawing No.	Part No.	Description	QWS42	QWS42-16	QWS48	QWS48-16
1	142-056	Cover	X	X		
1	142-068	Cover			X	X
2	136Y361	Left Side Seal Angle	X	X	X	X
3	104-988	Angle	2	2	2	2
4	110Y045	Left Side	X		X	
4	110Y048	Left Side		X		X
5	110-047	Top	X			
5	110-050	Top		X		
5	110-056	Top			X	
5	110-070	Top				X
6	7003-044	Mist Eliminator	X	X	X	X
7	130-120	Filter Tray	X	X		
7	130-128	Filter Tray			X	X
8	120-305	Partition	X			
8	120-309	Partition		X		
8	120-322	Partition			X	
8	120-348	Partition				X
9	110X045	Right Side	X		X	
9	110X048	Right Side		X		X
10	136X361	Right Side Seal Angle	X	X		
10	136-404	Right Side Seal Angle			X	X
11	111-046	Base	X			
11	111-049	Base		X		
11	111-055	Base			X	
11	111-071	Base				X