REPLACEMENT PARTS MANUAL

WALL MOUNTED PACKAGE HEAT PUMPS

Model: **WH243D**

General Notes

- Revised and/or additional pages may be issued from time to time.
- A complete and current manual consists of pages shown in the following contents section.

Important

- Contact the installing and/or local Bard distributor for all parts requirements. Make sure you have the complete model and serial number available from the unit rating plates.

Contents

Description	Page
Cabinet Components	
♦ Exploded View	1
♦ Usage List	2
Functional Components	
♦ Exploded View	3
♦ Usage List	4
Control Panel	
♦ Exploded View	5
♦ Usage List	6
Blower Assembly	
♦ Exploded View	7
♦ Usage List	7



BARD MANUFACTURING COMPANY
Bryan, Ohio 43506
Since 1914...Moving ahead, just as planned.

Manual: 2110-553A
Supersedes: 2110-553
File: Vol III Tab 17
Date: 07-23-04

CONTROL PANEL

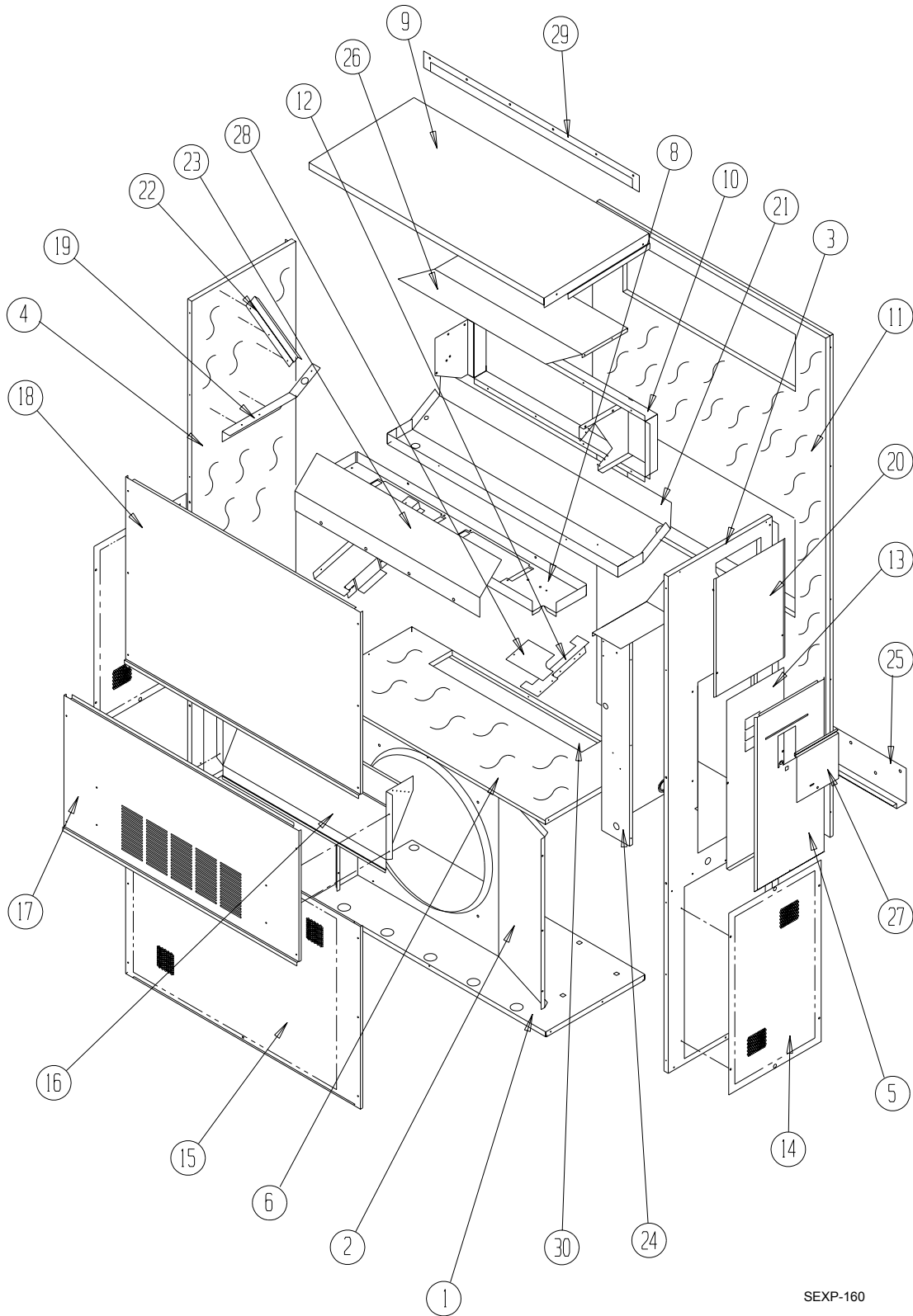

SEXP-160

CONTROL PANEL

Drawing No.	Part No.	Description	WH243DA,B	WH243DC
1	S127-204	Lower Base	X	X
2	125-023	Fan Shroud	X	X
3	S500-228-* ①	Right Side	X	X
4	S500-229-* ①	Left Side	X	X
5	S533-109-* ①	Control Panel Cover (Outer)	X	X
6	521X332	Condenser Partition	X	X
8	121-190	Blower Partition	X	X
9	S506-137-* ①	Top	X	X
10	S111-032	Outlet Airframe Assembly	X	X
11	S508-097	Back	X	X
12	113X195	Filter Bracket	2	2
13	S133-104	Control Panel (Inner)	X	
13	S133-110	Control Panel (Inner)		X
14	118-056-* ①	Side Grille	2	2
15	118-050-* ①	Condenser Grille	X	X
16	BFAD-2	Fresh Air Damper Assembly	X	X
17	S552-213-* ①	Service Door	X	X
18	S514-076-* ①	Upper Front	X	X
19	105X850	Left Side Support	X	X
20	143-034-* ①	Right Side Cover Plate (Outer)	X	X
21	S123-080	Drain Pan	X	X
22	147-044-* ①	Left Evaporator Support	X	X
23	137-195	Bottom Evaporator Fill	X	X
24	Control Panel	See Control Panel Assembly Drawing and Parts List Assembly	X	X
25	113-140	Bottom Mounting Bracket	1	1
26	135-127	Heat Shield	X	X
27	S153-218-* ①	Disconnect Access Door	X	X
28	137-259	Fill Plate	X	X
29	113-141-* ①	Top Rain Flashing	X	X

- ① Exterior cabinet parts are manufactured with various paint color options. To insure that you receive the proper paint color, you must include the complete model and serial number of the unit for which cabinet parts are being ordered.

FUNCTIONAL COMPONENTS

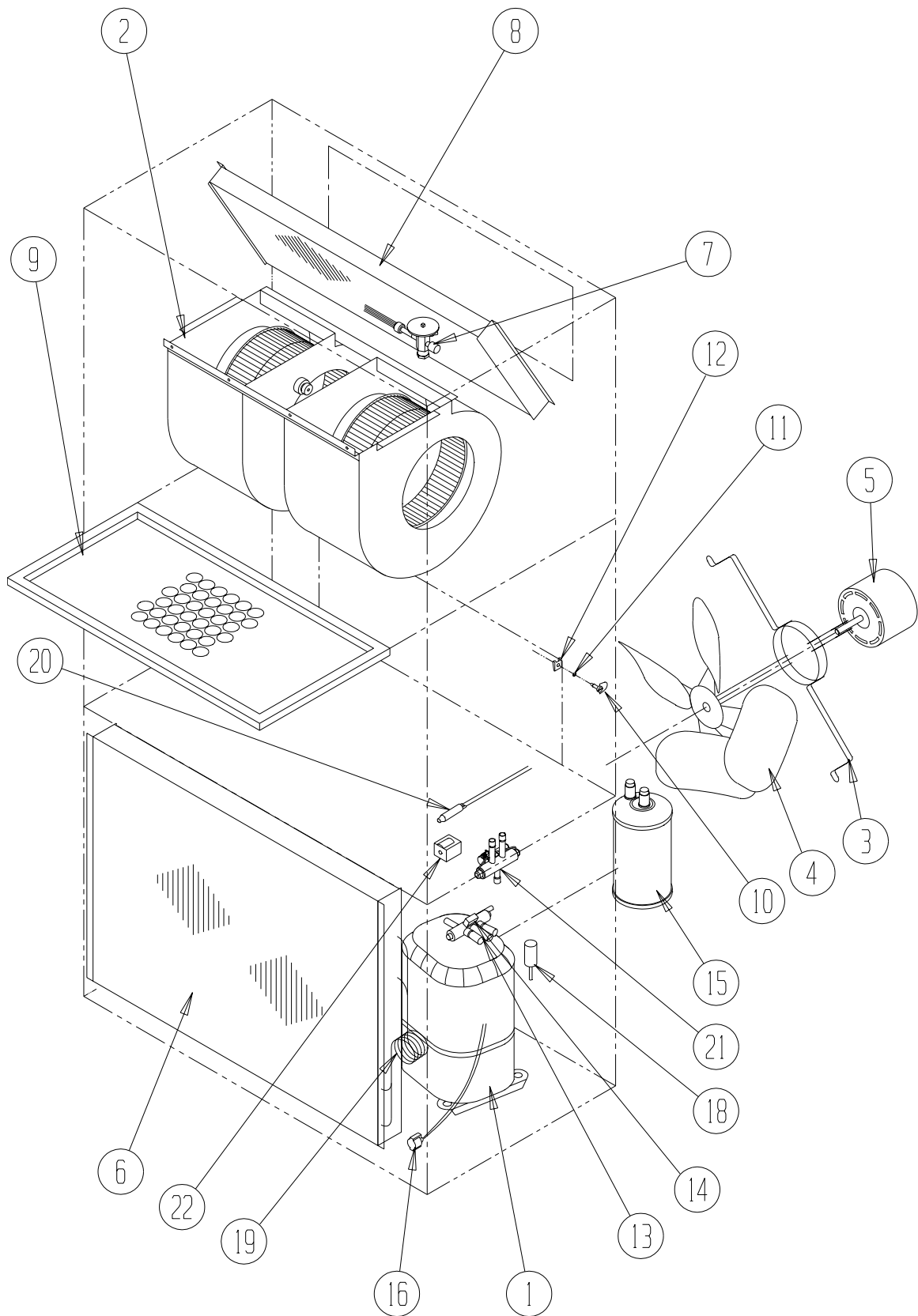

SEXP-331 B

FUNCTIONAL COMPONENTS

Drawing No.	Part No.	Description	WH243DA	WH243DB	WH243DC
1	8000-140	Compressor	X		
1	8000-141	Compressor		X	
1	8000-142	Compressor			X
2	S900-248	Blower Assembly	X	X	
2	S900-250	Blower Assembly			X
3	8200-001	Fan Motor Mount	X	X	X
4	5151-033	Fan Blade	X	X	
4	5151-046	Fan Blade			X
5	8103-016	Condenser Motor	X	X	
5	8103-020	Condenser Motor			X
6	5051-115	Condenser Coil	X	X	X
7	5651-157	Cooling TXV	X	X	X
8	917-0048	Evaporator Coil Assembly ①	X	X	X
9	7004-011	Air Filter 1" Throw-Away (16 x 25 x 1)	X	X	X
9	7003-032	Air Filter 1" Washable (Optional) (16 x 25 x 1)	X	X	X
9	7004-025	Air Filter 2" Pleated (Optional) (16 x 25 x 2)	X	X	X
10	1171-022	1/4" Turn Fastener	X	X	X
11	1171-024	1/4" Turn Retainer	X	X	X
12	1171-023	1/4" Receptacle	X	X	X
13	5650-020	Reversing Valve	X	X	X
14	5650-022	Reversing Valve Solenoid	X	X	X
15	5202-023	Accumulator	X	X	X
16	8620-095	Defrost Sensor	X	X	X
NS	1804-0106	High Pressure Switch Replacement Kit	X	X	X
19	800-0290	Heating Distributor w/.031 Orifice	X	X	X
20	800-0289	Drain Back Assembly	X	X	X
21	5650-036	Three Way Valve	X	X	X
22	5650-043	Solenoid Coil	X	X	X
NS	1804-0107	Low Pressure Switch Replacement Kit	X	X	X
NS	CMA-6	Low Ambient Control Replacement Kit	X	X	X

NS = Not Shown

① Includes the evaporator coil and hot gas reheat coil

CONTROL PANEL

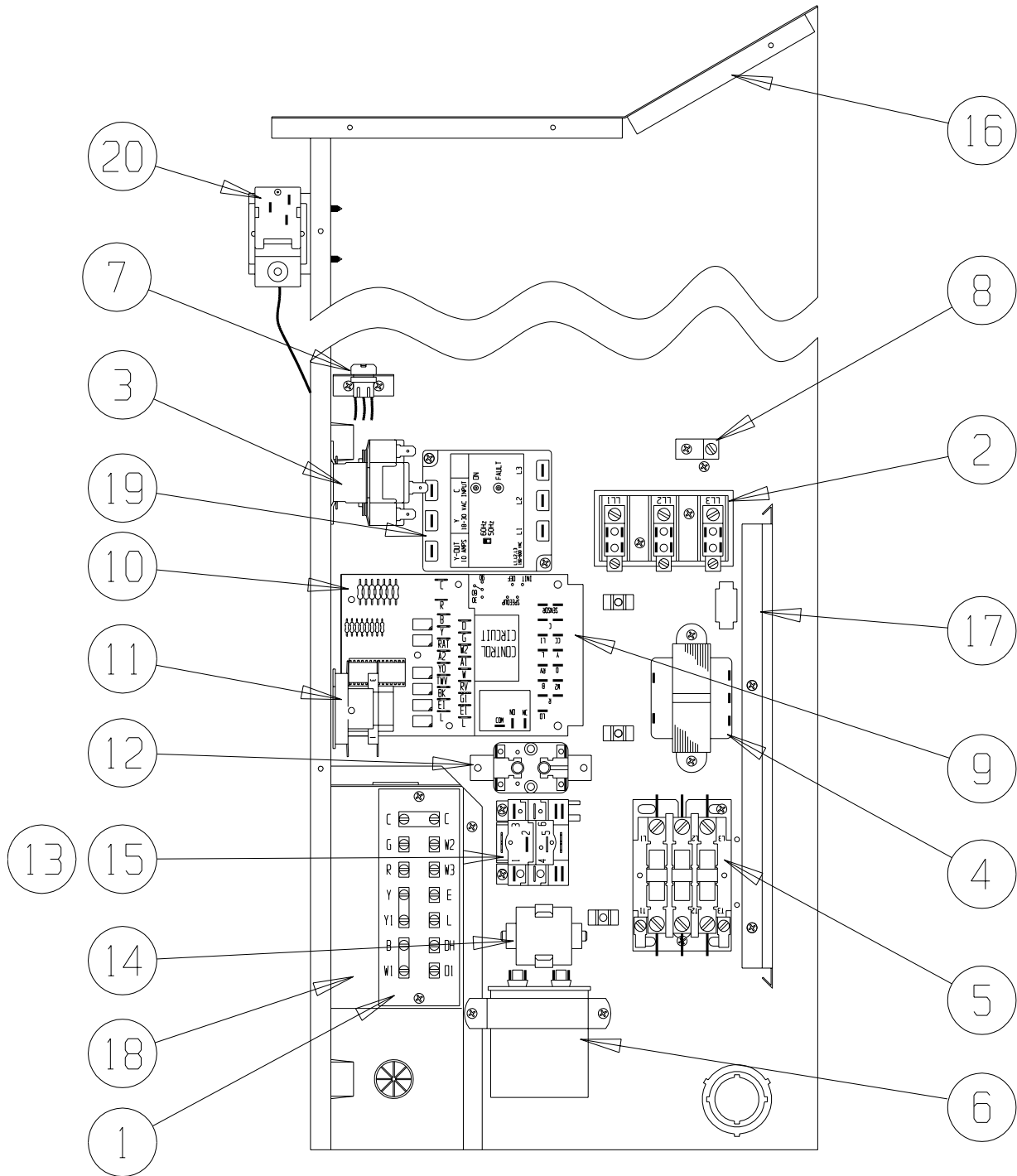

SEXP-396 A

CONTROL PANEL

Drawing No.	Part No.	Description	WH243DA	WH243DB	WH243DC
1	8607-019	Low Voltage Terminal Strip	X	X	X
2	8607-013	Terminal Block 2 Pole	X		
2	8607-014	Terminal Block 3 Pole		X	X
2	8607-015	Phenolic Insulator			X
3	8201-056	Blower Relay	X	X	
3	8201-032	Blower Control			X
4	8407-048	Transformer	X	X	
4	8407-042	Transformer			X
5	8401-007	Compressor Contactor (25 Amp 1 Pole)	X		
5	8401-002	Compressor Contactor (25 Amp 3 Pole)		X	X
6	8552-047	Compressor Capacitor (30/5 MFD 370V)	X		
6	8552-002	Outdoor Motor Capacitor (5MFD 370V)		X	X
7	3000-971	6 Pin Connector	X	X	X
8	8611-006	Ground Terminal	X	X	X
9	8201-101	Heat Pump Control Board	X	X	X
10	8201-092	Dehumidification Logic Board ①	X	X	X
11	8201-065	Low Pressure Bypass TDR ①	X	X	X
12	8201-009	LAC Bypass Relay ①	X	X	X
13	8607-017	LAC Terminal Block ①	X	X	X
14	8551-004	Start Device ①	X		
15	8201-032	Outdoor Fan Relay			X
16	517X137	Control Panel Top	X	X	X
17	135-122	Wire Shield	X	X	X
18	117X123	Control Panel	X	X	X
NS	4096-130	Wiring Diagram	X		
NS	4096-231	Wiring Diagram		X	
NS	4096-232	Wiring Diagram			X

NS = Not Shown

① = Optional

BLOWER ASSEMBLY

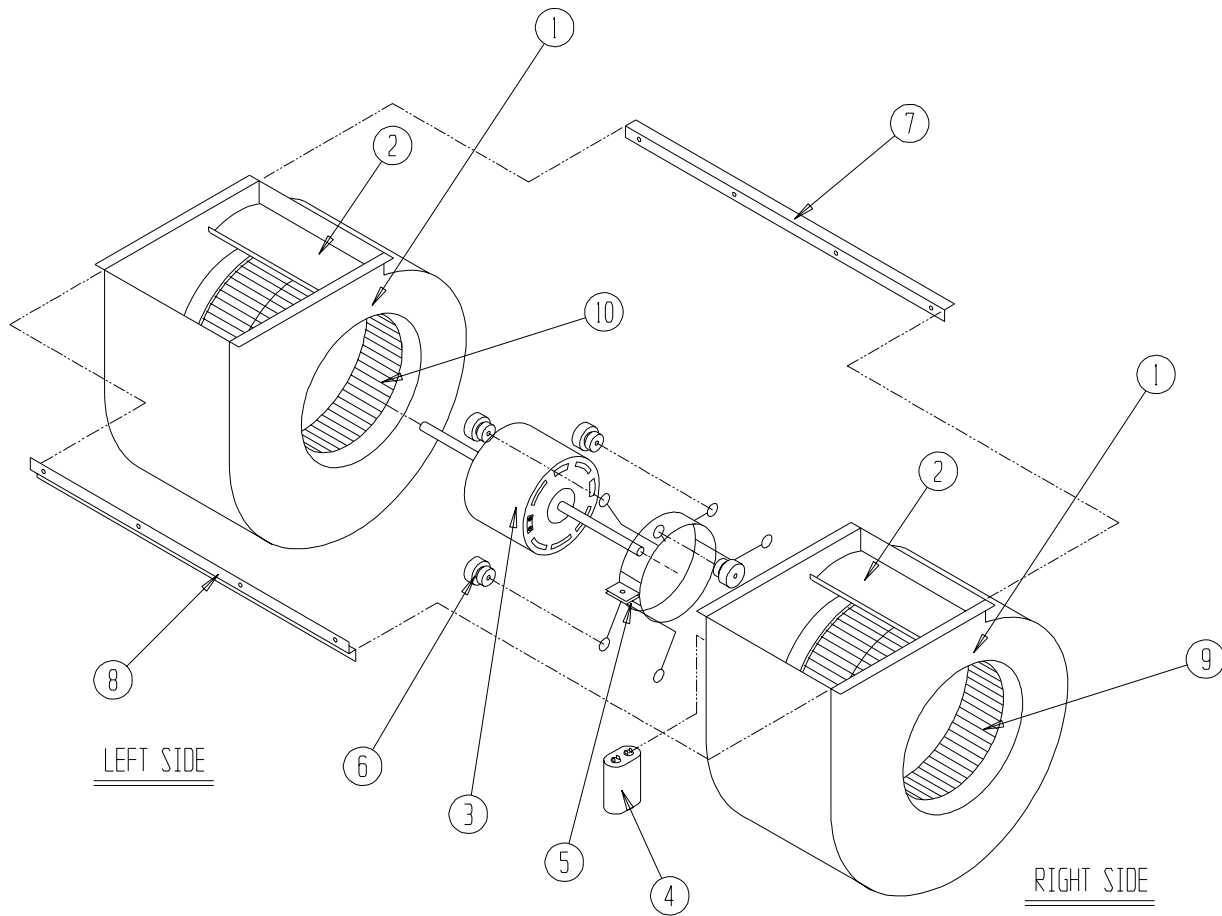

SEXP-346

Drawing No.	Part No.	Description	S900-248	S900-250
1	151-115	Housing	X	X
2	144-183	Cutoff	X	X
3	8102-011	Blower Motor (230/208)	X	
3	8105-033	Blower Motor (460)		X
4	8552-002	Capacitor	X	X
5	8200-031	Motor Mount	X	X
6	5451-011	Grommets	6	6
7	105-1061	Back Brace	X	X
8	103-435	Front Brace	X	X
9	5152-092	Wheel 9-6 CW	X	X
10	5152-093	Wheel 9-6 CCW	X	X