

---

# REPLACEMENT PARTS MANUAL

# WALL MOUNTED PACKAGE HEAT PUMPS

Models: **CH3S1**  
**CH4S1**  
**CH5S1**

---

## General Notes

- Revised and/or additional pages may be issued from time to time.
- A complete and current manual consists of pages shown in the following contents section.

## Important

- Contact the installing and/or local Bard distributor for all parts requirements. Make sure you have the complete model and serial number available from the unit rating plate.

## Contents

| Description           | Page   |
|-----------------------|--------|
| Cabinet Components    |        |
| ♦ Exploded View ..... | 2      |
| ♦ Usage List .....    | 3 & 4  |
| Blank Page            |        |
| ♦ Blank Page .....    | 5      |
| Functional Components |        |
| ♦ Exploded View ..... | 6      |
| ♦ Usage List .....    | 7      |
| Control Panel         |        |
| ♦ Layout View .....   | 8 & 10 |
| ♦ Usage List .....    | 9 & 11 |
| Blower Housing        |        |
| ♦ Exploded View ..... | 12     |
| ♦ Usage List .....    | 12     |



Bard Manufacturing Company, Inc.  
Bryan, Ohio 43506  
*Since 1914...Moving ahead, just as planned.*

Manual: 2110-556K  
Supersedes: 2110-556J  
File: Tab 17  
Date: 08-20-10

# CABINET COMPONENTS

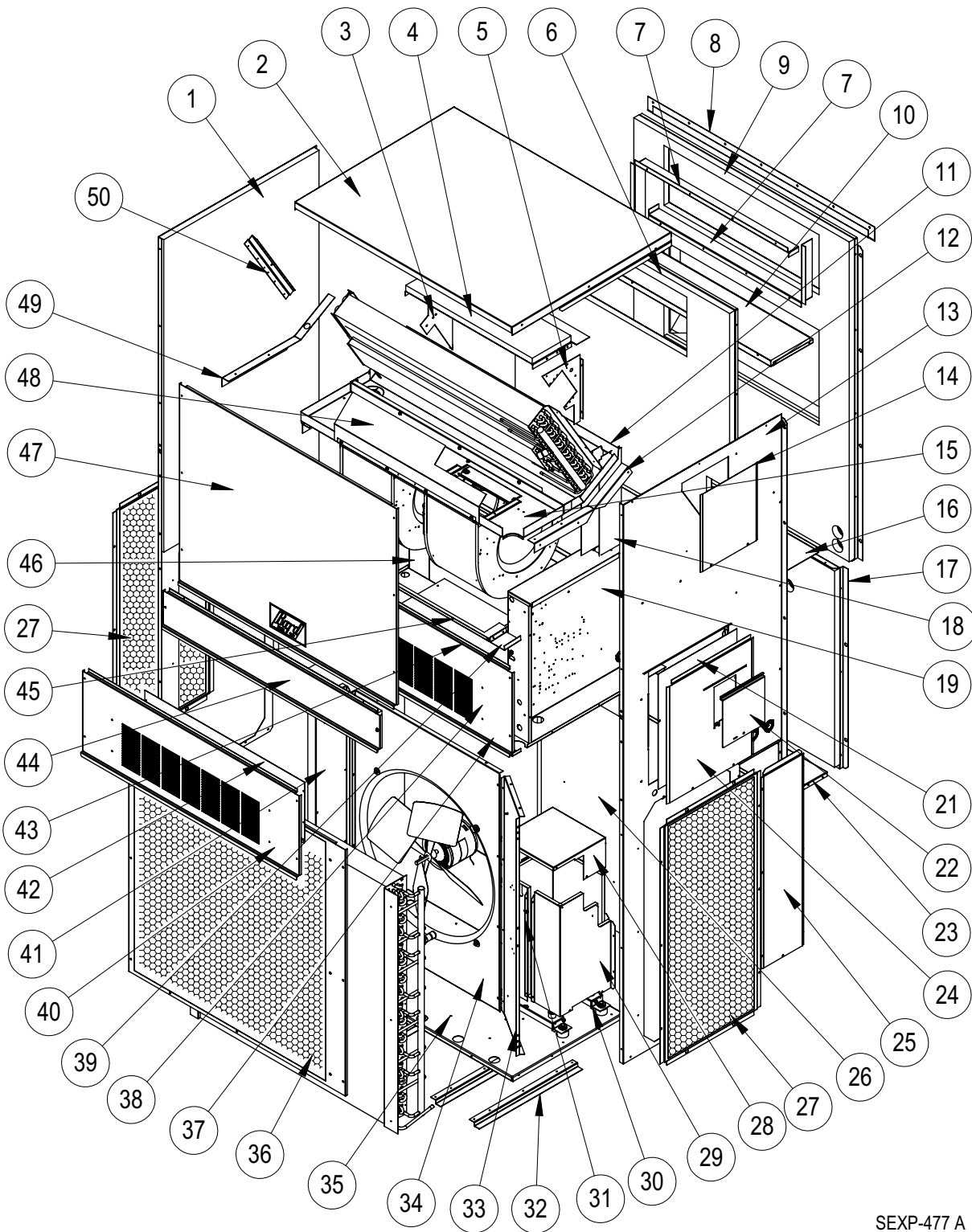

SEXP-477 A

# CABINET COMPONENTS

| Drawing No. | Part No.                               | Description                         | CH3S1 | CH4S1 | CH5S1 |
|-------------|--|-------------------------------------|-------|-------|-------|
| 1           | S501-476-* ①                           | Left Side                           | X     |       |       |
| 1           | S501-456-* ①                           | Left Side                           |       | X     | X     |
| 2           | 507-247-* ①                            | Top                                 | X     | X     | X     |
| 3           | 112-317                                | Left Heater Bracket                 | X     | X     | X     |
| 4           | 134-232                                | Heat Shield                         | X     | X     | X     |
| 5           | 112-316                                | Right Heater Bracket                | X     | X     | X     |
| 6           | 509-180                                | Upper Inner Back                    | X     | X     | X     |
| 7           | 111-115                                | Outlet Airframe Assembly            | X     | X     | X     |
| 8           | 113-150-* ①                            | Top Rain Flashing                   | X     | X     | X     |
| 9           | 509-181                                | Upper Outer Back                    | X     | X     | X     |
| 10          | 521-396                                | Supply Partition                    | X     | X     | X     |
| 11          | S523-112                               | Drain Pan Assembly                  | X     | X     | X     |
| 12          | 105X878                                | Support Angle                       | X     | X     | X     |
| 13          | S501-475-* ①                           | Right Side                          | X     |       |       |
| 13          | S501-457-* ①                           | Right Side                          |       | X     | X     |
| 14          | S543-108-* ①                           | Right Side Cover Plate (Outer)      | X     | X     | X     |
| 15          | 121X216                                | Blower Partition RH                 | X     | X     | X     |
| 16          | 537-503                                | Dehum Option Fill Plate             | X     | X     | X     |
| 17          | 509-196                                | Lower Outer Back Assembly           | X     |       |       |
| 17          | 509-183                                | Lower Outer Back Assembly           |       | X     | X     |
| 18          | 135-128                                | Wire Raceway                        | X     | X     | X     |
| 19          | Control Panel<br>(See Dwg./Parts List) | Control Panel Assembly              |       |       |       |
| 21          | S132-114                               | Control Panel Cover (Inner)         | X     | X     | X     |
| 22          | S153-218-* ①                           | Disconnect Access Door              | X     | X     | X     |
| 23          | 527-345                                | Rear Base Assembly                  | X     | X     | X     |
| 24          | S533-191-* ①                           | Control Panel Cover (Outer)         | X     | X     | X     |
| 25          | 553-403-* ①                            | Rear Option Door                    | X     |       |       |
| 25          | 553-390-* ①                            | Rear Option Door                    |       | X     | X     |
| 26          | 509-195                                | Lower Inner Back                    | X     |       |       |
| 26          | 509-182                                | Lower Inner Back                    |       | X     | X     |
| 27          | 118-057-* ①                            | Side Grille                         | 2     |       |       |
| 27          | 118-058-* ①                            | Side Grille                         |       | 2     | 2     |
| 28          | 543-100                                | Compressor Enclosure (Top)          | X     | X     | X     |
| 29          | S543-102                               | Compressor Enclosure Cover Assembly | X     | X     | X     |

① Exterior cabinet parts are manufactured with various paint color options. To insure that you receive the proper paint color, you must include the complete model and serial number of the unit for which cabinet parts are being ordered.

## CABINET COMPONENTS (Continued)

| Drawing No. | Part No.     | Description                 | CH3S1 | CH4S1 | CH5S1 |
|-------------|--------------|-----------------------------|-------|-------|-------|
| 30          | S102-459     | Compressor Rail             | 2     | 2     | 2     |
| 31          | 543-101      | Compressor Enclosure (Back) | X     | X     | X     |
| 32          | 102-458      | Base Offset                 | 3     | 3     | 3     |
| 33          | 125-054      | Fan Shroud (Right Side)     | X     |       |       |
| 33          | 125-049      | Fan Shroud (Right Side)     |       | X     | X     |
| 34          | 124-053      | Fan Shroud (Center)         | X     |       |       |
| 34          | 124-048      | Fan Shroud (Center)         |       | X     | X     |
| 35          | 126-342-X    | Lower Base                  | X     | X     | X     |
| 36          | 118-048-* ①  | Condenser Grille            | X     |       |       |
| 36          | 118-052-* ①  | Condenser Grille            |       | X     | X     |
| 37          | 521-408      | Condenser Partition         | X     | X     | X     |
| 38          | 536-489      | CRV Exhaust Blank-Off Plate | X     | X     | X     |
| 39          | 137-209      | Fill Plate Filter           | X     |       |       |
| 40          | 553-383-* ①  | Vent Option Door            | X     | X     | X     |
| 41          | 125-052      | Fan Shroud (Left)           | X     |       |       |
| 41          | 125-047      | Fan Shroud (Left)           |       | X     | X     |
| 42          | 542-043-X    | Blank-Off Plate             | X     | X     | X     |
| 43          | 536-531      | ERV Exhaust Blank-Off Plate | X     | X     | X     |
| 44          | 553-384-* ①  | Filter Door                 | X     | X     | X     |
| 45          | 131X099      | Filter Tray                 | X     | X     | X     |
| 46          | 137-487      | Left Return Plate           | X     | X     | X     |
| 47          | S515-144-* ① | Upper Front                 | X     | X     | X     |
| 48          | 134-175      | Air Baffle                  | X     | X     | X     |
| 49          | 105X877      | Left Side Support           | X     | X     | X     |
| 50          | 146-046      | Evaporator Offset Angle     | X     | X     | X     |
| NS          | 507-250-* ①  | Top                         | X     | X     | X     |
| NS          | 110-114      | Top Outlet Frame            | 2     | 2     | 2     |
| NS          | 536-491      | Supply Blank Off Plate      | X     | X     | X     |

NS = Not Shown (The NS Parts listed above are for top outlet units.)

① Exterior cabinet parts are manufactured with various paint color options. To insure that you receive the proper paint color, you must include the complete model and serial number of the unit for which cabinet parts are being ordered.

**This Page Intentionally Left Blank**

# FUNCTIONAL COMPONENTS

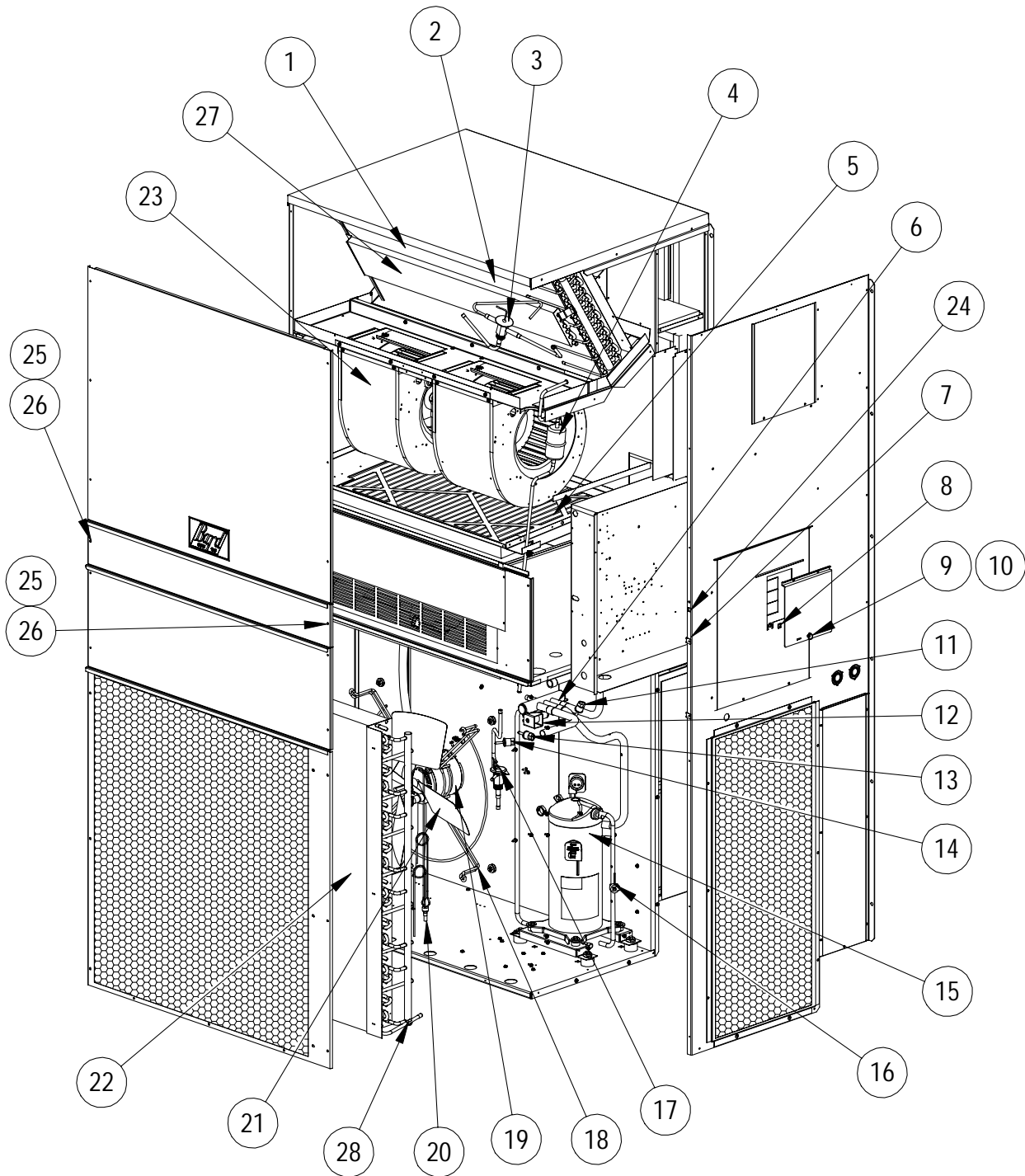

SEXP-478 D

# FUNCTIONAL COMPONENTS

| Dwg. No. | Part Number  | Description                                      | CH3S1-A | CH3S1-B | CH3S1-C | CH4S1-A | CH4S1-B | CH4S1-C | CH5S1-A | CH5S1-B | CH5S1-C |
|----------|--------------|--|---------|---------|---------|---------|---------|---------|---------|---------|---------|
| 1        | 5060-124BX   | Evaporator Coil                                  | X       | X       | X       |         |         |         |         |         |         |
| 1        | 5060-123BX   | Evaporator Coil                                  |         |         |         | X       | X       | X       | X       | X       | X       |
| 2        | S800-0342    | Distributor - Cooling                            |         |         |         | X       | X       | X       | X       | X       | X       |
| 2        | S800-0346    | Distributor - Cooling                            | X       | X       | X       |         |         |         |         |         |         |
| 3        | 5651-174     | TXV - Cooling                                    | X       | X       | X       |         |         |         |         |         |         |
| 3        | 5651-172     | TXV - Cooling                                    |         |         |         | X       | X       | X       |         |         |         |
| 3        | 5651-182     | TXV - Cooling                                    |         |         |         |         |         |         | X       | X       | X       |
| 4        | 5201-010     | Filter Drier                                     | X       | X       | X       | X       | X       | X       | X       | X       | X       |
| 5        | 7004-027     | Air Filter                                       | X       | X       | X       | X       | X       | X       | X       | X       | X       |
| 6        | 5650-039     | Reversing Valve with 24V Solenoid                | X       | X       | X       |         |         |         |         |         |         |
| 6        | 5650-040     | Reversing Valve with 24V Solenoid                |         |         |         | X       | X       | X       |         |         |         |
| 6        | 5650-041     | Reversing Valve with 24V Solenoid                |         |         |         |         |         |         | X       | X       | X       |
| 7        | 1012-314     | U-Clip Fastener                                  | 4       | 4       | 4       | 4       | 4       | 4       | 4       | 4       | 4       |
| 8        | 1171-023     | Receptacle                                       | X       | X       | X       | X       | X       | X       | X       | X       | X       |
| 9        | 1171-022     | 1/4 Turn Fastener                                | X       | X       | X       | X       | X       | X       | X       | X       | X       |
| 10       | 1171-024     | Retainer Clip                                    | X       | X       | X       | X       | X       | X       | X       | X       | X       |
| 11       | 1804-0287    | Low Pressure Switch, Blue Leads, 14 PSIG Cut Out | X       | X       | X       | X       | X       | X       | X       | X       | X       |
| 12       | 5650-042     | Rev. Valve Solenoid, Red Casing (Ranco)          | X       | X       | X       | X       | X       | X       | X       | X       | X       |
| 12       | 5650-043     | Rev. Valve Solenoid, Black Casing (Wilspec)      | X       | X       | X       | X       | X       | X       | X       | X       | X       |
| 12       | 5650-046     | Rev. Valve Solenoid, Black Casing (San Hua)      | X       | X       | X       | X       | X       | X       | X       | X       | X       |
| 13       | 1804-0327    | High Pressure Switch, Red Leads, 575PSIG Cut Out | X       | X       | X       | X       | X       | X       | X       | X       | X       |
| 14       | 1804-0316    | High Pressure Switch, Red Leads, 540PSIG Cut Out | X       | X       | X       | X       | X       | X       | X       | X       | X       |
| 15       | 8000-269     | Compressor                                       | X       |         |         |         |         |         |         |         |         |
| 15       | 8000-272     | Compressor                                       |         | X       |         |         |         |         |         |         |         |
| 15       | 8000-275     | Compressor                                       |         |         | X       |         |         |         |         |         |         |
| 15       | 8000-267     | Compressor                                       |         |         |         | X       |         |         |         |         |         |
| 15       | 8000-270     | Compressor                                       |         |         |         |         | X       |         |         |         |         |
| 15       | 8000-273     | Compressor                                       |         |         |         |         |         | X       |         |         |         |
| 15       | 8000-268     | Compressor                                       |         |         |         |         |         |         | X       |         |         |
| 15       | 8000-271     | Compressor                                       |         |         |         |         |         |         |         | X       |         |
| 15       | 8000-274     | Compressor                                       |         |         |         |         |         |         |         |         | X       |
| 16       | 8408-039     | Discharge Line Thermostat                        | X       | X       | X       | X       | X       | X       | X       | X       | X       |
| 17       | 5651-174     | TXV - Heating                                    | X       | X       | X       |         |         |         |         |         |         |
| 17       | 5651-172     | TXV - Heating                                    |         |         |         | X       | X       | X       | X       | X       | X       |
| 18       | 8200-004     | Fan Motor Mount                                  | X       | X       | X       | X       | X       | X       | X       | X       | X       |
| 19       | 8105-039     | Condenser Motor                                  | X       | X       |         | X       | X       |         | X       | X       |         |
| 19       | 8105-030     | Condenser Motor                                  |         |         | X       |         |         | X       |         |         | X       |
| 20       | S800-0345    | Distributor - Heating                            | X       | X       | X       |         |         |         |         |         |         |
| 20       | S800-0343    | Distributor - Heating                            |         |         |         | X       | X       | X       | X       | X       | X       |
| 21       | 5151-054     | Fan Blade  | X       | X       | X       | X       | X       | X       | X       | X       | X       |
| 22       | 5051-142BX   | Condenser Coil                                   | X       | X       | X       |         |         |         |         |         |         |
| 22       | 5051-130BX   | Condenser Coil                                   |         |         |         | X       | X       | X       | X       | X       | X       |
| 23       | S900-272-002 | Blower Assembly - Complete                       | X       | X       | X       |         |         |         |         |         |         |
| 23       | S900-273-001 | Blower Assembly - Complete                       |         |         |         | X       | X       | X       |         |         |         |
| 23       | S900-273-004 | Blower Assembly - Complete                       |         |         |         |         |         |         | X       | X       | X       |
| 24       | 1171-028     | Clip On Receptacle                               | 2       | 2       | 2       | 2       | 2       | 2       | 2       | 2       | 2       |
| 25       | 1171-057     | Captive Screw                                    | 2       | 2       | 2       | 2       | 2       | 2       | 2       | 2       | 2       |
| 26       | 1171-027     | Retainer for Captive Screw                       | 2       | 2       | 2       | 2       | 2       | 2       | 2       | 2       | 2       |
| 27       | 5051-141BX   | Sub-Cooling Condenser Coil                       |         |         |         |         |         |         | X       | X       | X       |
| 28       | 8620-095     | Defrost Sensor                                   | X       | X       | X       | X       | X       | X       | X       | X       | X       |
| NS       | 8407-003     | 460V Step Down Transformer (Not Shown)           |         |         | X       |         |         |         |         |         |         |
| NS       | 8407-004     | 460V Step Down Transformer (Not Shown)           |         |         |         |         |         | X       |         |         | X       |
| NS       | CMH-17       | Low Ambient Control 230V (Optional)              | X       | X       |         | X       | X       |         | X       | X       |         |
| NS       | CMH-18       | Low Ambient Control 460V (Optional)              |         |         | X       |         |         | X       |         |         | X       |
| NS       | 5202-026     | Suction Accumulator                              |         |         |         |         |         |         | X       | X       | X       |

NS = Not Shown

# CONTROL PANEL COMPONENTS

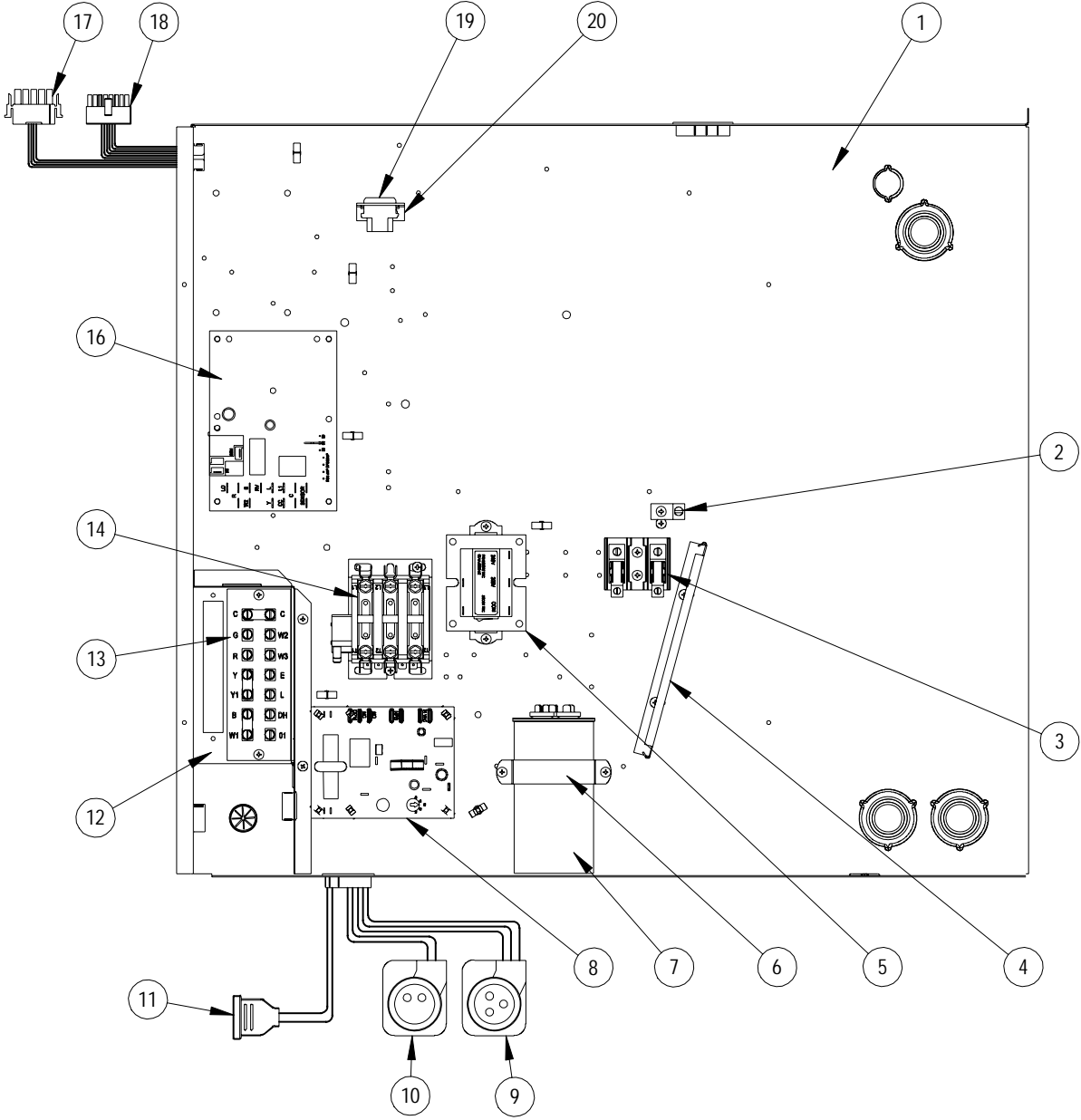

SEXP-479 A



## CONTROL PANEL COMPONENTS

---

| Drawing No. | Part No.    | Description                    | CH3S1-A | CH4S1-A | CH5S1-A |
|-------------|-------------|--------------------------------|---------|---------|---------|
| 1           | 517-259     | Control Panel                  | X       | X       | X       |
| 2           | 8611-006    | Ground Terminal                | X       | X       | X       |
| 3           | 8607-013    | Terminal Block 2-Pole          | X       | X       | X       |
| 4           | 135-130     | Wire Shield                    | X       | X       | X       |
| 5           | 8407-048    | Transformer                    | X       | X       | X       |
| 6           | 8550-008    | Capacitor Strap                | X       | X       | X       |
| 7           | 8552-080    | Capacitor                      | X       |         |         |
| 7           | 8552-079    | Capacitor                      |         | X       |         |
| 7           | 8552-058    | Capacitor                      |         |         | X       |
| 8           | 8201-105-24 | Compressor Current Monitor     | X       |         |         |
| 8           | 8201-105-30 | Compressor Current Monitor     |         | X       |         |
| 8           | 8201-105-37 | Compressor Current Monitor     |         |         | X       |
| 9           | 3000-1222   | Compressor Plug (High Voltage) | X       | X       | X       |
| 10          | 3000-1223   | Compressor Plug (Low Voltage)  | X       | X       | X       |
| 11          | 5650-037    | Reversing Valve Plug           | X       | X       | X       |
| 12          | 117X139     | Low Voltage Box                | X       | X       | X       |
| 13          | 8607-019    | Low Voltage Terminal Strip     | X       | X       | X       |
| 14          | 8401-027    | Contactora 30 Amp 3-Pole       | X       | X       | X       |
| 16          | 8620-214    | Defrost Board Kit              | X       | X       | X       |
| 17          | 3000-1221   | ECM High Voltage Wiring        | X       | X       | X       |
| 18          | 3000-1345   | ECM Low Voltage Wiring         | X       | X       | X       |
| 19          | 3000-1346   | Heater Plug                    | X       | X       | X       |
| 20          | 141-188     | Heater Plug Bracket            | X       | X       | X       |
| NS          | 4096-153    | Wiring Diagram                 | X       | X       | X       |

NS = Not Shown

# CONTROL PANEL COMPONENTS

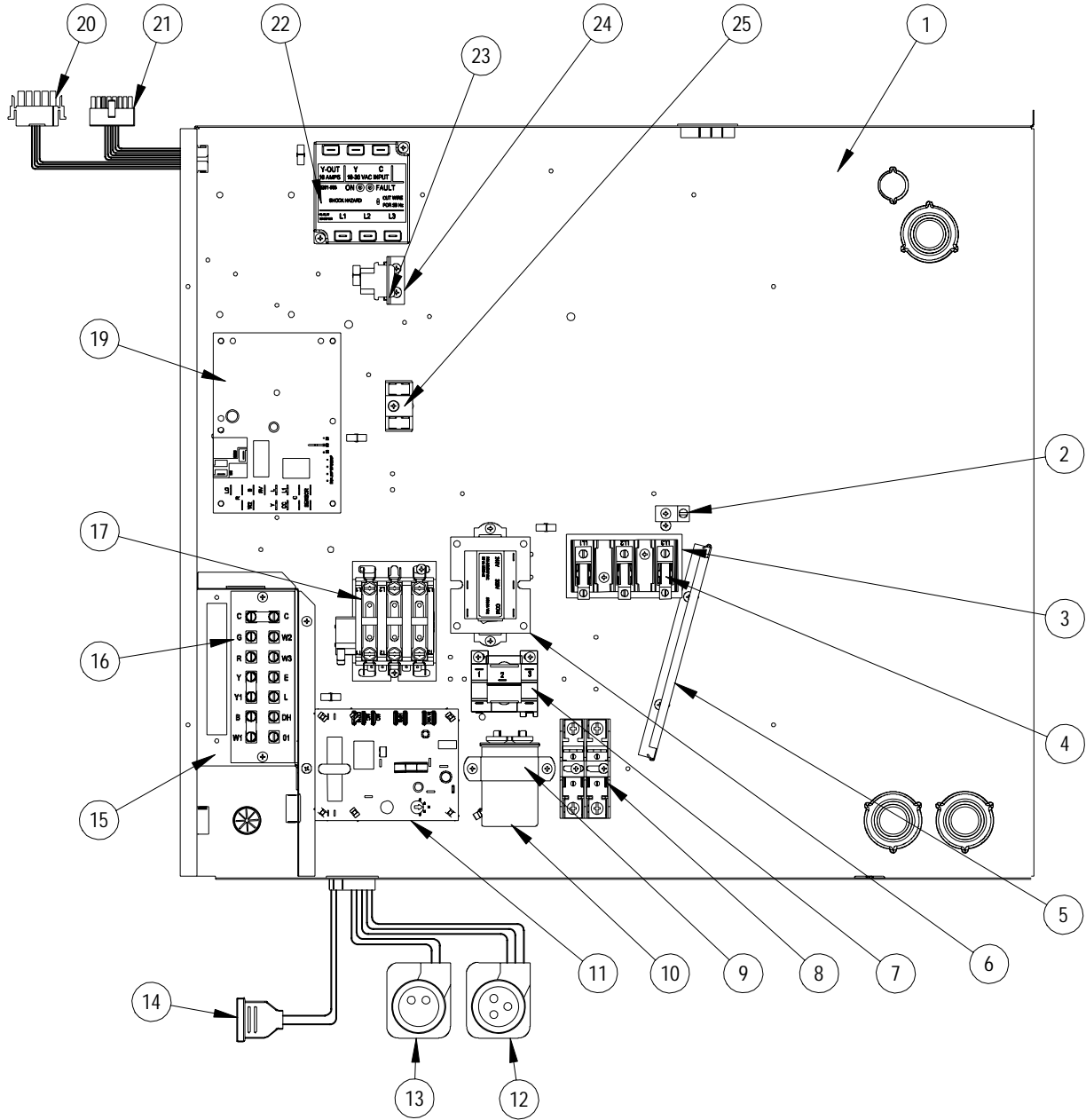

SEXP-480 A

## CONTROL PANEL COMPONENTS

| Drawing No. | Part No.    | Description                    | CH3S1-B | CH3S1-C | CH4S1-B | CH4S1-C | CH5S1-B | CH5S1-C |
|-------------|-------------|--------------------------------|---------|---------|---------|---------|---------|---------|
| 1           | 517-259     | Control Panel                  | X       | X       | X       | X       | X       | X       |
| 2           | 8611-006    | Ground Terminal                | X       | X       | X       | X       | X       | X       |
| 3           | 8607-015    | Phenolic Insulator             |         | X       |         | X       |         | X       |
| 4           | 8607-014    | Terminal Block 3-Pole          | X       | X       | X       | X       | X       | X       |
| 5           | 135-130     | Wire Shield                    | X       | X       | X       | X       | X       | X       |
| 6           | 8407-048    | Transformer                    | X       | X       | X       | X       | X       | X       |
| 7           | 8201-032    | Relay                          |         | X       |         | X       |         | X       |
| 8           | 8614-041    | Fuse Block                     |         | X       |         | X       |         | X       |
| 9           | 8550-003    | Capacitor Strap                | X       |         | X       |         | X       |         |
| 9           | 8550-006    | Capacitor Strap                |         | X       |         | X       |         | X       |
| 10          | 8552-005    | Capacitor                      | X       |         | X       |         | X       |         |
| 10          | 8552-026    | Capacitor                      |         | X       |         | X       |         | X       |
| 11          | 8201-105-16 | Compressor Current Monitor     | X       |         |         |         |         |         |
| 11          | 8201-105-06 | Compressor Current Monitor     |         | X       |         |         |         |         |
| 11          | 8201-105-19 | Compressor Current Monitor     |         |         | X       |         |         |         |
| 11          | 8201-105-09 | Compressor Current Monitor     |         |         |         | X       |         |         |
| 11          | 8201-105-25 | Compressor Current Monitor     |         |         |         |         | X       |         |
| 11          | 8201-105-13 | Compressor Current Monitor     |         |         |         |         |         | X       |
| 12          | 3000-1230   | Compressor Plug (High Voltage) | X       | X       | X       | X       | X       | X       |
| 13          | 3000-1223   | Compressor Plug (Low Voltage)  | X       | X       | X       | X       | X       | X       |
| 14          | 5650-037    | Reversing Valve Plug           | X       | X       | X       | X       | X       | X       |
| 15          | 117X139     | Low Voltage Box                | X       | X       | X       | X       | X       | X       |
| 16          | 8607-019    | Low Voltage Terminal Strip     | X       | X       | X       | X       | X       | X       |
| 17          | 8401-027    | Contact                        | X       | X       | X       | X       | X       | X       |
| 19          | 8620-214    | Defrost Board Kit              | X       | X       | X       | X       | X       | X       |
| 20          | 3000-1221   | ECM High Voltage Wiring        | X       | X       | X       | X       | X       | X       |
| 21          | 3000-1345   | ECM Low Voltage Wiring         | X       | X       | X       | X       | X       | X       |
| 22          | 8201-085    | Phase Monitor                  | X       | X       | X       | X       | X       | X       |
| 23          | 3000-1346   | Heater Plug                    | X       | X       | X       | X       | X       | X       |
| 24          | 141-188     | Heater Plug Bracket            | X       | X       | X       | X       | X       | X       |
| 25          | 8607-017    | Terminal Block 2-Pole          | X       | X       | X       | X       | X       | X       |
| NS          | 4096-253    | Wiring Diagram                 | X       |         | X       |         | X       |         |
| NS          | 4096-354    | Wiring Diagram                 |         | X       |         | X       |         | X       |

NS = Not Shown

# BLOWER ASSEMBLY

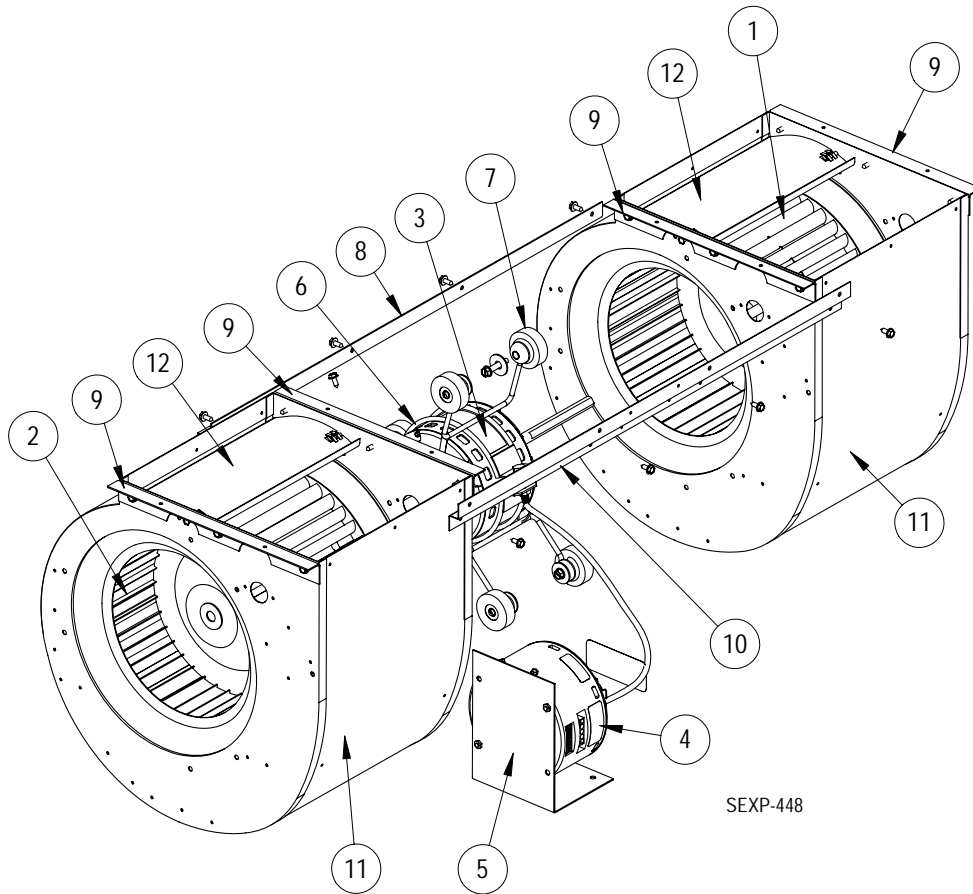

SEXP-448

| Drawing No. | Part No.        | Description                   | S900-272-002 | S900-273-001 | S900-273-004 |
|-------------|-----------------|-------------------------------|--------------|--------------|--------------|
| 1           | 5152-011        | 10-Inch Wheel (CW)            | X            | X            | X            |
| 2           | 5152-012        | 10-Inch Wheel (CCW)           | X            | X            | X            |
| 3           | S8106-041-0040A | 1/2 HP Programmed Motor       | X            |              |              |
| 3           | S8107-011-0038A | 3/4 HP Programmed Motor       |              | X            |              |
| 3           | S8107-011-0035  | 3/4 HP Programmed Motor       |              |              | X            |
| 4           | C8106-041-0040A | Programmed Motor Control Only | X            |              |              |
| 4           | C8107-011-0038A | Programmed Motor Control Only |              | X            |              |
| 4           | C8107-011-0035  | Programmed Motor Control Only |              |              | X            |
| 5           | 112-314         | Blower Motor Control Bracket  | X            | X            | X            |
| 6           | 8200-040        | Motor Mount                   | X            | X            | X            |
| 7           | 5451-011        | Grommets                      | 6            | 6            | 6            |
| 8           | 105-881         | Back Brace                    | X            | X            | X            |
| 9           | 105-880         | Side Angle                    | 4            | 4            | 4            |
| 10          | 103-389         | Front Brace                   | X            | X            | X            |
| 11          | 151-101         | Housing                       | 2            | 2            | 2            |
| 12          | 144-166         | Diffuser                      | 2            | 2            | 2            |