

---

# REPLACEMENT PARTS MANUAL

# WALL MOUNTED PACKAGE HEAT PUMPS

Models: **CH3S1**  
**CH4S1**  
**CH5S1**

---

## General Notes

- Revised and/or additional pages may be issued from time to time.
- A complete and current manual consists of pages shown in the following contents section.

## Important

- Contact the installing and/or local Bard distributor for all parts requirements. Make sure you have the complete model and serial number available from the unit rating plate.

## Contents

Description	Page
Cabinet Components	
♦ Exploded View.....	2
♦ Usage List .....	3 & 4
Blank Page	
♦ Blank Page .....	5
Functional Components	
♦ Exploded View.....	6
♦ Usage List .....	7
Control Panel	
♦ Layout View.....	8 & 10
♦ Usage List .....	9 & 11
Blower Housing	
♦ Exploded View.....	12
♦ Usage List .....	12



Bard Manufacturing Company, Inc.  
Bryan, Ohio 43506  
*Since 1914...Moving ahead, just as planned.*

Manual: 2110-556Q  
Supersedes: 2110-556P  
File: Tab 17  
Date: 03-06-13  
**REVISED: 7-29-22**

# CABINET COMPONENTS

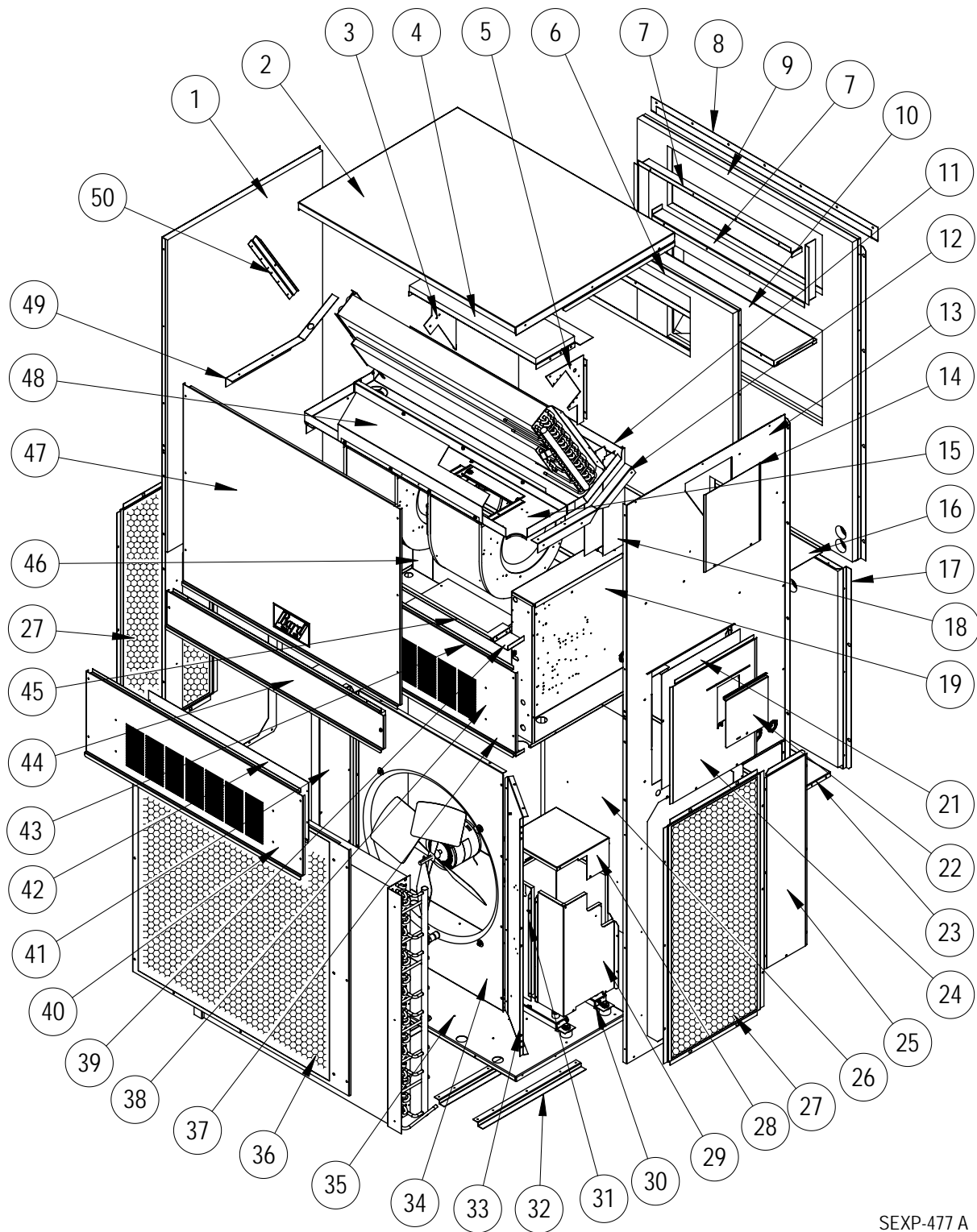

SEXP-477 A

# CABINET COMPONENTS

Drawing No.	Part No.	Description	CH3S1	CH4S1	CH5S1
1	S501-476-* ①	Left Side	X		
1	S501-456-* ①	Left Side		X	X
2	507-247-* ①	Top	X	X	X
3	112-317	Left Heater Bracket	X	X	X
4	134-232	Heat Shield	X	X	X
5	112-316	Right Heater Bracket	X	X	X
6	509-180	Upper Inner Back	X	X	X
7	111-115	Outlet Airframe Assembly	X	X	X
8	113-150-* ①	Top Rain Flashing	X	X	X
9	509-181	Upper Outer Back	X	X	X
10	521-396	Supply Partition	X	X	X
11	S523-112	Drain Pan Assembly	X	X	X
12	105X878	Support Angle	X	X	X
13	S501-475-* ①	Right Side	X		
13	S501-457-* ①	Right Side		X	X
14	S543-108-* ①	Right Side Cover Plate (Outer)	X	X	X
15	121X216	Blower Partition RH	X	X	X
16	537-503	Dehum. Option Fill Plate	X	X	X
17	509-196	Lower Outer Back Assembly	X		
17	509-183	Lower Outer Back Assembly		X	X
18	135-128	Wire Raceway	X	X	X
19	Control Panel (See Dwg./Parts List)	Control Panel Assembly			
21	S132-114	Control Panel Cover (Inner)	X	X	X
22	S153-218-* ①	Disconnect Access Door	X	X	X
23	127-360	Rear Base	X	X	X
23	543-113	Rear Base Cover Plate Assembly	X	X	X
24	S533-191-* ①	Control Panel Cover (Outer)	X	X	X
25	553-403-* ①	Rear Option Door	X		
25	553-390-* ①	Rear Option Door		X	X
26	509-195	Lower Inner Back	X		
26	509-182	Lower Inner Back		X	X
27	118-057-* ①	Side Grille	2		
27	118-058-* ①	Side Griller		2	2
28	543-100	Compressor Enclosure (Top)	X	X	X
29	S543-102	Compressor Enclosure Cover Assembly	X	X	X

① Exterior cabinet parts are manufactured with various paint color options. To ensure that you receive the proper paint color, you must include the complete model and serial number of the unit for which cabinet parts are being ordered.

## CABINET COMPONENTS (Continued)

Drawing No.	Part No.	Description	CH3S1	CH4S1	CH5S1
30	S102-459	Compressor Rail	2	2	2
31	543-101	Compressor Enclosure (Back)	X	X	X
32	102-458	Base Offset	3	3	3
33	125-054	Fan Shroud (Right Side)	X		
33	125-049	Fan Shroud (Right Side)		X	X
34	124-053	Fan Shroud (Center)	X		
34	124-048	Fan Shroud (Center)		X	X
35	126-342-X	Lower Base	X	X	X
36	118-048-* ①	Condenser Grille	X		
36	118-052-* ①	Condenser Grille		X	X
37	521-408	Condenser Partition	X	X	X
38	536-489	CRV Exhaust Blank-Off Plate	X	X	X
39	137-209	Fill Plate Filter	X		
40	553-383-* ①	Vent Option Door	X	X	X
41	125-052	Fan Shroud (Left)	X		
41	125-047	Fan Shroud (Left)		X	X
42	542-043-X	Blank-Off Plate	X	X	X
43	536-531	ERV Exhaust Blank-Off Plate	X	X	X
44	553-384-* ①	Filter Door	X	X	X
45	131X099	Filter Tray	X	X	X
46	137-487	Left Return Plate	X	X	X
47	S515-144-* ①	Upper Front	X	X	X
48	134-175	Air Baffle	X	X	X
49	105X877	Left Side Support	X	X	X
50	146-046	Evaporator Offset Angle	X	X	X
NS	507-250-* ①	Top	X	X	X
NS	110-114	Top Outlet Frame	2	2	2
NS	536-491	Supply Blank Off Plate	X	X	X

NS = Not Shown (The NS Parts listed above are for top outlet units.)

① Exterior cabinet parts are manufactured with various paint color options. To ensure that you receive the proper paint color, you must include the complete model and serial number of the unit for which cabinet parts are being ordered.

***This Page Intentionally Left Blank***

# FUNCTIONAL COMPONENTS

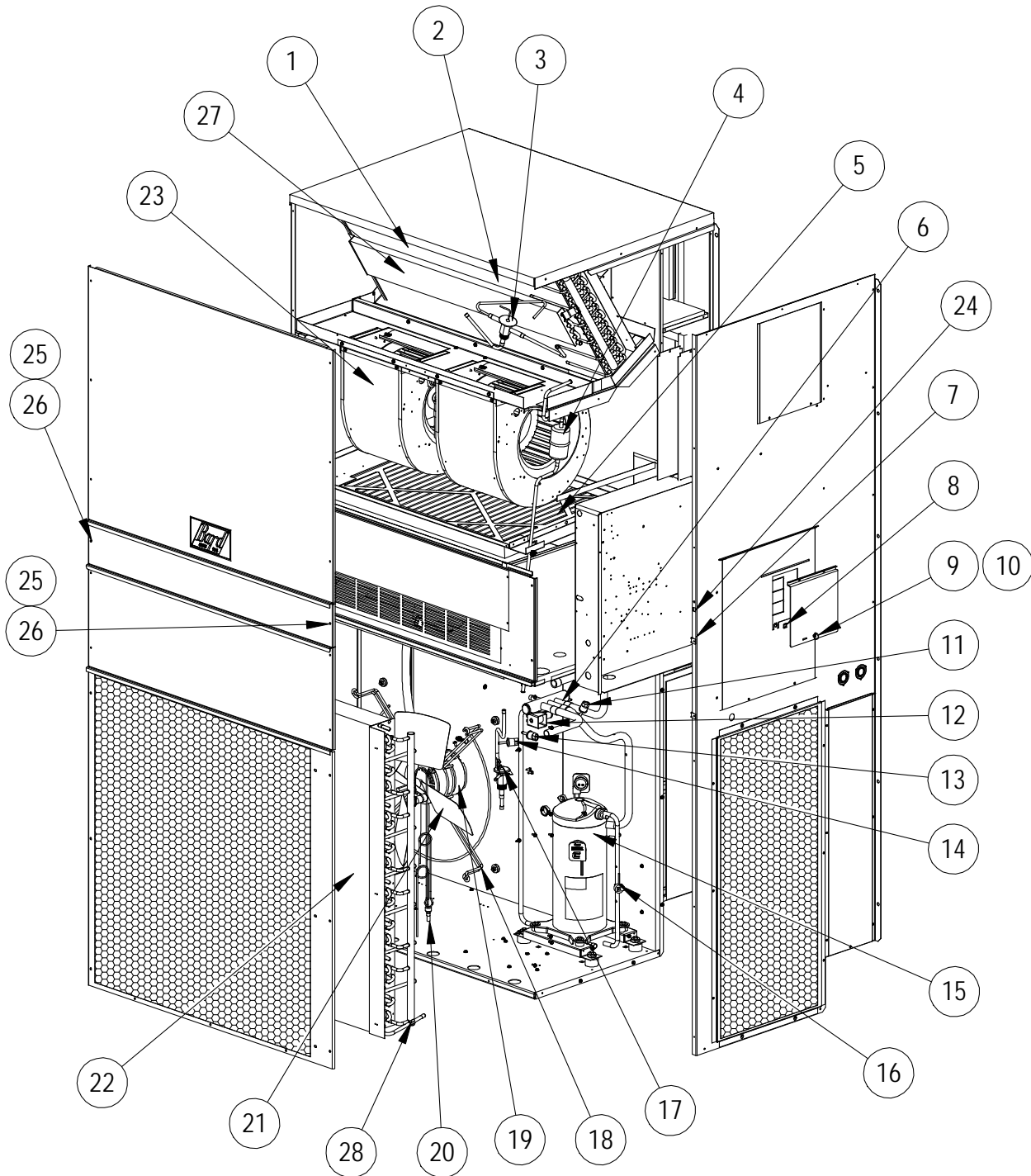

SEXP-478 D

# FUNCTIONAL COMPONENTS

Drawing No.	Part No.	Description	CH3S1-A	CH3S1-B	CH3S1-C	CH4S1-A	CH4S1-B	CH4S1-C	CH5S1-A	CH5S1-B	CH5S1-C
1	5060-124BX	Evaporator Coil	X	X	X	X	X	X	X	X	X
1	5060-123BX	Evaporator Coil									
2	S800-0342	Distributor - Cooling				X	X	X	X	X	X
2	S800-0346	Distributor - Cooling	X	X	X						
3	5651-174	TXV - Cooling	X	X	X						
3	5651-172	TXV - Cooling				X	X	X			
3	5651-182	TXV - Cooling							X	X	X
4	5201-010	Filter Drier	X	X	X	X	X	X	X	X	X
5	7004-027	Air Filter	X	X	X	X	X	X	X	X	X
6	5650-039	Reversing Valve with 24V Solenoid	X	X	X						
6	5650-040	Reversing Valve with 24V Solenoid				X	X	X	X	X	X
7	1012-314	U-Clip Fastener	4	4	4	4	4	4	4	4	4
8	1171-023	Receptacle	X	X	X	X	X	X	X	X	X
9	1171-022	1/4 Turn Fastener	X	X	X	X	X	X	X	X	X
10	1171-024	Retainer Clip	X	X	X	X	X	X	X	X	X
11	1804-0287	Low Pressure Switch, Blue Leads, 14 PSIG Cut Out	X	X	X	X	X	X	X	X	X
12	5650-042	Rev. Valve Solenoid, Red Casing (Ranco)	X	X	X	X	X	X	X	X	X
12	5650-043	Rev. Valve Solenoid, Black Casing (Wilspec)	X	X	X	X	X	X	X	X	X
12	5650-046	Rev. Valve Solenoid, Black Casing (San Hua)	X	X	X	X	X	X	X	X	X
13	1804-0327	High Pressure Switch, Red Leads, 575PSIG Cut Out	X	X	X	X	X	X	X	X	X
14	1804-0316	High Pressure Switch, Red Leads, 540PSIG Cut Out	X	X	X	X	X	X	X	X	X
15	8000-269	Compressor	X								
15	8000-272	Compressor		X							
15	8000-275	Compressor			X						
15	8000-267	Compressor				X					
15	8000-270	Compressor					X				
15	8000-273	Compressor						X			
15	8000-268	Compressor							X		
15	8000-271	Compressor								X	
15	8000-274	Compressor									X
16	8408-039	Discharge Line Thermostat	X	X	X	X	X	X	X	X	X
17	5651-174	TXV - Heating	X	X	X						
17	5651-172	TXV - Heating				X	X	X	X	X	X
18	8200-004	Fan Motor Mount	X	X	X	X	X	X	X	X	X
19	8105-039	Condenser Motor	X	X		X	X		X	X	
19	8105-030	Condenser Motor			X			X			X
20	S800-0345	Distributor - Heating	X	X	X						
20	S800-0343	Distributor - Heating				X	X	X	X	X	X
21	5151-054	Fan Blade	X	X	X	X	X	X	X	X	X
22	5051-142BX	Condenser Coil	X	X	X						
22	5051-130BX	Condenser Coil				X	X	X	X	X	X
23	S900-272-002	Blower Assembly - Complete	X	X	X						
23	S900-273-001	Blower Assembly - Complete				X	X	X			
23	S900-273-004	Blower Assembly - Complete							X	X	X
24	1171-028	Clip On Receptacle	2	2	2	2	2	2	2	2	2
25	1171-057	Captive Screw	2	2	2	2	2	2	2	2	2
26	1171-027	Retainer for Captive Screw	2	2	2	2	2	2	2	2	2
27	5051-141BX	Sub-Cooling Condenser Coil							X	X	X
28	8620-224	Defrost Sensor	X	X	X	X	X	X	X	X	X
NS	8407-005	460V Step Down Transformer (Not Shown)						X			
NS	8407-004	460V Step Down Transformer (Not Shown)			X						X
NS	CMH-17	Low Ambient Control 230V (Optional)	X	X		X	X		X	X	
NS	CMH-18	Low Ambient Control 460V (Optional)			X			X			X
NS	5202-026	Suction Accumulator							X	X	X

NS = Not Shown

# CONTROL PANEL COMPONENTS

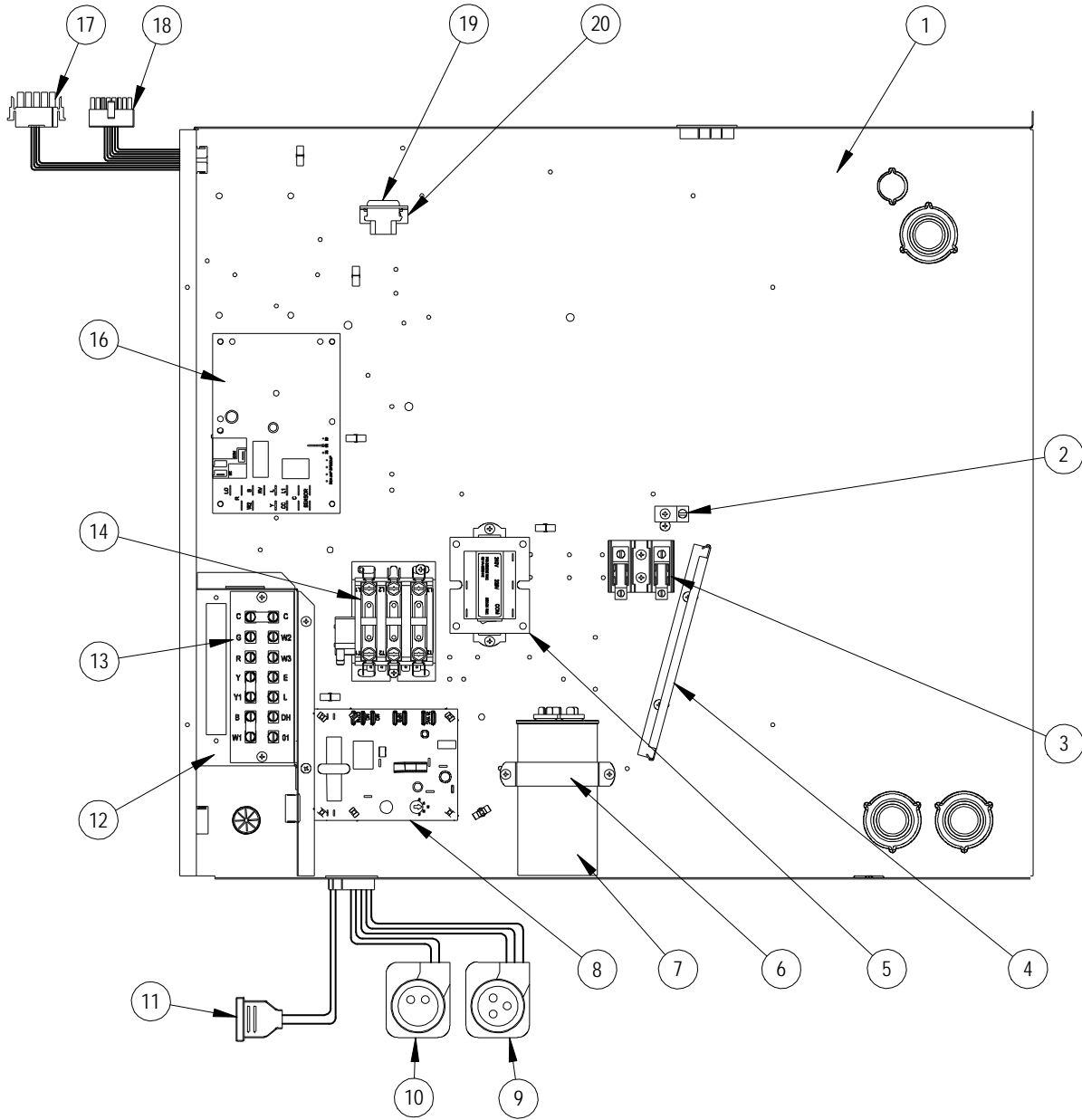

SEXP-479 A



# CONTROL PANEL COMPONENTS

---

Drawing No.	Part No.	Description	CH3S1-A	CH4S1-A	CH5S1-A
1	517-259	Control Panel	X	X	X
2	8611-006	Ground Terminal	X	X	X
3	8607-013	Terminal Block 2-Pole	X	X	X
4	135-130	Wire Shield	X	X	X
5	8407-048	Transformer	X	X	X
6	8550-008	Capacitor Strap	X	X	X
7	8552-080	Capacitor	X		
7	8552-079	Capacitor		X	
7	8552-058	Capacitor			X
8	8201-105-24	Compressor Current Monitor	X		
8	8201-105-30	Compressor Current Monitor		X	
8	8201-105-37	Compressor Current Monitor			X
9	3000-1222	Compressor Plug (High Voltage)	X	X	X
10	3000-1223	Compressor Plug (Low Voltage)	X	X	X
11	5650-037	Reversing Valve Plug	X	X	X
12	117X139	Low Voltage Box	X	X	X
13	8607-019	Low Voltage Terminal Strip	X	X	X
14	8401-027	Contactora 30 Amp 3-Pole	X	X	X
16	8620-223	Defrost Board Kit	X	X	X
17	3000-1221	ECM High Voltage Wiring	X	X	X
18	3000-1345	ECM Low Voltage Wiring	X	X	X
19	3000-1346	Heater Plug	X	X	X
20	141-188	Heater Plug Bracket	X	X	X
NS	4096-153	Wiring Diagram	X	X	X

NS = Not Shown

# CONTROL PANEL COMPONENTS

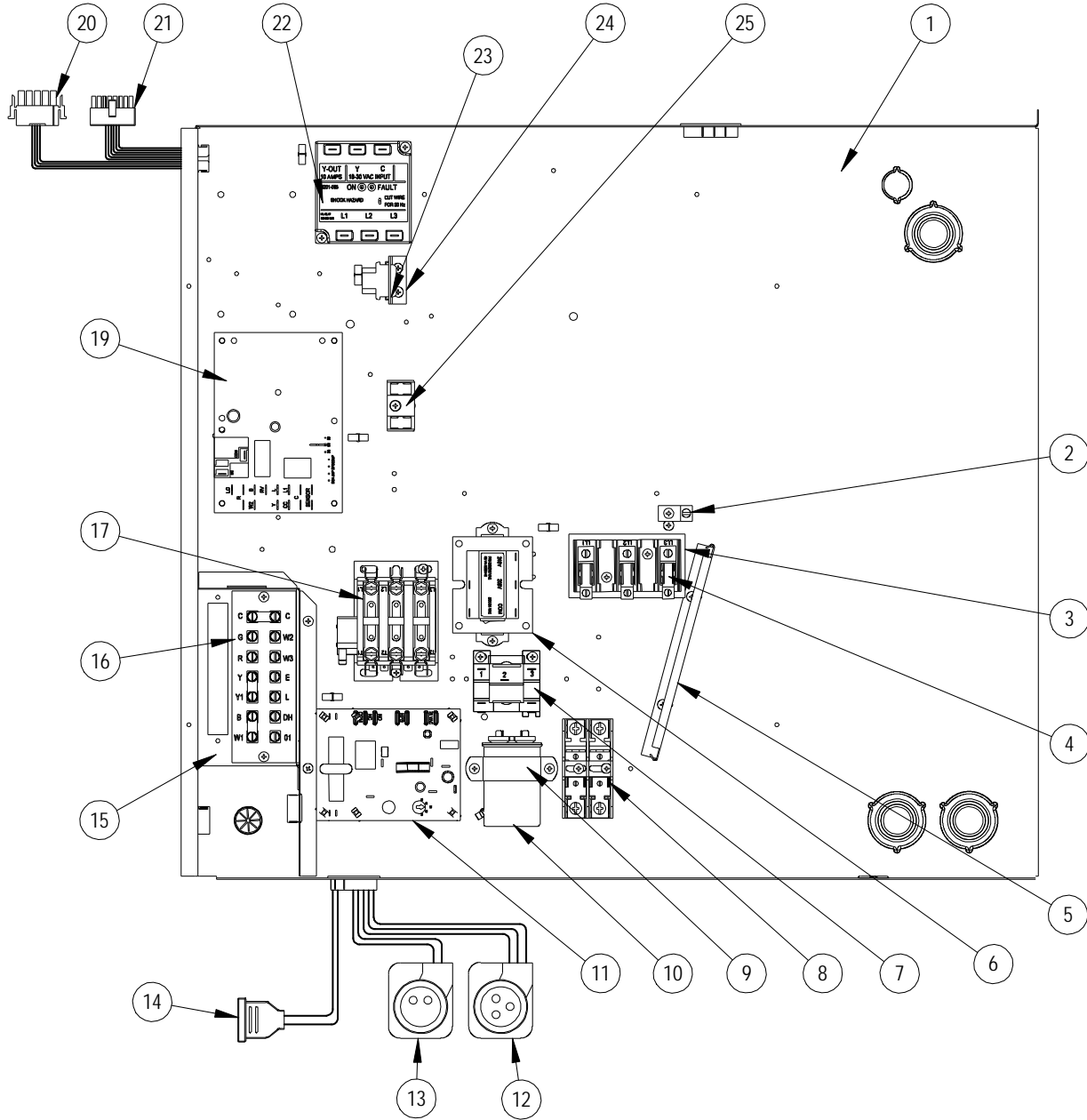

SEXP-480 A

# CONTROL PANEL COMPONENTS

Drawing No.	Part No.	Description	CH3S1-B	CH3S1-C	CH4S1-B	CH4S1-C	CH5S1-B	CH5S1-C
1	517-259	Control Panel	X	X	X	X	X	X
2	8611-006	Ground Terminal	X	X	X	X	X	X
3	8607-015	Phenolic Insulator		X		X		X
4	8607-014	Terminal Block 3-Pole	X	X	X	X	X	X
5	135-130	Wire Shield	X	X	X	X	X	X
6	8407-048	Transformer	X	X	X	X	X	X
7	8201-032	Relay		X		X		X
8	8614-041	Fuse Block		X		X		X
9	8550-003	Capacitor Strap	X		X		X	
9	8550-006	Capacitor Strap		X		X		X
10	8552-005	Capacitor	X		X		X	
10	8552-026	Capacitor		X		X		X
11	8201-105-16	Compressor Current Monitor	X					
11	8201-105-06	Compressor Current Monitor		X				
11	8201-105-19	Compressor Current Monitor			X			
11	8201-105-09	Compressor Current Monitor				X		
11	8201-105-25	Compressor Current Monitor					X	
11	8201-105-13	Compressor Current Monitor						X
12	3000-1230	Compressor Plug (High Voltage)	X	X	X	X	X	X
13	3000-1223	Compressor Plug (Low Voltage)	X	X	X	X	X	X
14	5650-037	Reversing Valve Plug	X	X	X	X	X	X
15	117X139	Low Voltage Box	X	X	X	X	X	X
16	8607-019	Low Voltage Terminal Strip	X	X	X	X	X	X
17	8401-027	Contactora	X	X	X	X	X	X
19	8620-223	Defrost Board Kit	X	X	X	X	X	X
20	3000-1221	ECM High Voltage Wiring	X	X	X	X	X	X
21	3000-1345	ECM Low Voltage Wiring	X	X	X	X	X	X
22	8201-085	Phase Monitor	X	X	X	X	X	X
23	3000-1346	Heater Plug	X	X	X	X	X	X
24	141-188	Heater Plug Bracket	X	X	X	X	X	X
25	8607-017	Terminal Block 2-Pole	X	X	X	X	X	X
NS	4096-253	Wiring Diagram	X		X		X	
NS	4096-354	Wiring Diagram		X		X		X

NS = Not Shown

# BLOWER ASSEMBLY

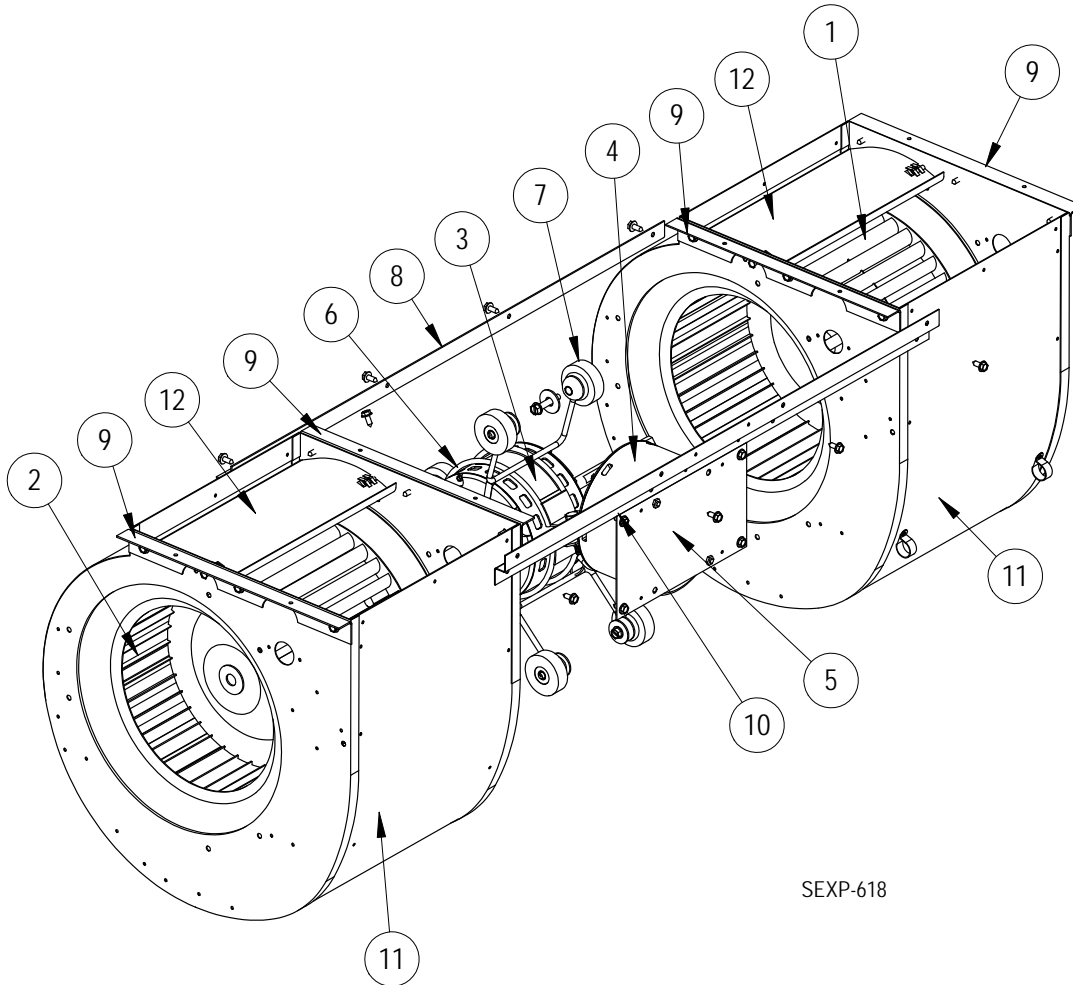

SEXP-618

Drawing No.	Part No.	Description	S900-272-002	S900-273-001	S900-273-004
1	5152-011	10-Inch Wheel (CW)	X	X	X
2	5152-012	10-Inch Wheel (CCW)	X	X	X
3	8106-073-0040BX	1/2 HP Programmed Motor	X		
3	8107-017-0038BX	3/4 HP Programmed Motor		X	
3	8107-017-0035BX	3/4 HP Programmed Motor			X
4	C8106-052-0040	Programmed Motor Control Only	X		
4	C8107-017-0038	Programmed Motor Control Only		X	
4	C8107-017-0035	Programmed Motor Control Only			X
5	112-344	Blower Motor Control Bracket	X	X	X
6	8200-040	Motor Mount	X	X	X
7	5451-011	Grommets	6	6	6
8	105-881	Back Brace	X	X	X
9	105-880	Side Angle	4	4	4
10	103-389	Front Brace	X	X	X
11	151-101	Housing	2	2	2
12	144-166	Diffuser	2	2	2