



REPLACEMENT PARTS MANUAL

WALL MOUNTED PACKAGE HEAT PUMPS

Models: **W30H1** **W30H1D**
W36H1 **W36H1D**

General Notes

- Revised and/or additional pages may be issued from time to time.
- A complete and current manual consists of pages shown in the following contents section.

Important

- Contact the installing and/or local Bard distributor for all parts requirements. Make sure you have the complete model and serial number available from the unit rating plate.

Contents

Description	Page
Cabinet Components	
♦ Exploded View	2
♦ Usage List	3
Functional Components	
♦ Exploded View	4
♦ Usage List	5
Functional Components - Dehum. Models	
♦ Usage List	6
Control Panel	
♦ Layout View.....	7
♦ Usage List	8
Control Panel	
♦ Layout View.....	9
♦ Usage List - Dehum.	10
Blower Housing	
♦ Exploded View	11
♦ Usage List	11



Bard Manufacturing Company, Inc.
 Bryan, Ohio 43506
Since 1914...Moving ahead, just as planned.

Manual: 2110-572I
 Supersedes: 2110-572H
 File: Tab 17
 Date: 08-22-13

CABINET COMPONENTS

Drawing No.	Part No.	Description	W30H1-A,-B	W30H1-C	W36H1-A,-B	W36H1-C	W30H1DA,DB	W30H1DC	W36H1DA,DB	W36H1DC
1	S127-199	Lower Base	X	X	X	X	X	X	X	X
1	S127-368 ③	Lower Base	X	X	X	X	X	X	X	X
2	125-022	Fan Shroud	X	X	X	X	X	X	X	X
2	125-057 ③	Fan Shroud	X	X	X	X	X	X	X	X
3	S500-228-* ①	Right Side	X	X	X	X	X	X	X	X
3	S500-527 ③	Right Side	X	X	X	X	X	X	X	X
4	S500-229-* ①	Left Side	X	X	X	X	X	X	X	X
4	S500X528 ③	Left Side	X	X	X	X	X	X	X	X
5	S533-109-* ①	Control Panel Cover (Outer)	X	X	X	X	X	X	X	X
5	S533-197 ③	Control Panel Cover (Outer)	X	X	X	X	X	X	X	X
6	S521X384	Condenser Partition	X	X	X	X	X	X	X	X
8	121X182	Blower Partition	X	X	X	X	X	X	X	X
9	S506-130-* ①	Top	X	X	X	X	X	X	X	X
9	S506-275 ③	Top	X	X	X	X	X	X	X	X
10	S111X030	Outlet Airframe Assembly	X	X	X	X	X	X	X	X
11	S508-088	Back	X	X	X	X	X	X	X	X
11	S508-222 ③	Back	X	X	X	X	X	X	X	X
12	113X195	Filter Bracket	2	2	2	2	2	2	2	2
13	S132-104	Control Panel Cover (Inner)	X		X		X		X	
13	S132-172	Control Panel Cover (Inner)		X		X		X		X
14	118-056-* ①	Side Grille	2	2	2	2	2	2	2	2
14	118-067 ③	Side Grille	2	2	2	2	2	2	2	2
15	118-059-* ①	Condenser Grille	X	X	X	X	X	X	X	X
15	118-066 ③	Condenser Grille	X	X	X	X	X	X	X	X
16	BFAD-3	Fresh Air Damper Assembly	X	X	X	X	X	X	X	X
17	S552-443-* ①	Vent Option Door	X	X	X	X	X	X	X	X
17	S552-445-* ①	Vent Option Door with ERV	X	X	X	X	X	X	X	X
17	S552-458 ③	Vent Option Door	X	X	X	X	X	X	X	X
18	S514-160-* ①	Upper Front	X	X	X	X	X	X	X	X
18	S514-166 ③	Upper Front	X	X	X	X	X	X	X	X
19	105X850	Left Side Support	X	X	X	X	X	X	X	X
20	S143-034-* ①	Right Side Cover Plate (Outer)	X	X	X	X	X	X	X	X
20	S143-127 ③	Right Side Cover Plate (Outer)	X	X	X	X	X	X	X	X
21	S123-078	Drain Pan	X	X	X	X	X	X	X	X
22	147-044	Evaporator Support	X	X	X	X	X	X	X	X
23	135-124	Air Baffle	X	X	X	X	X	X	X	X
24	Control Panel Assembly	See Control Panel Assy. Drawing & Parts List	X	X	X	X	X	X	X	X
25	113-140	Bottom Mounting Bracket	1	1	1	1	1	1	1	1
26	135X123	Heat Shield	X	X	X	X	X	X	X	X
27	S153-218-* ①	Disconnect Access Door	X	X	X	X	X	X	X	X
27	S153-405 ③	Disconnect Access Door	X	X	X	X	X	X	X	X
28	137-259	Fill Plate	X	X	X	X	X	X	X	X
29	113-149-* ①	Top Rain Flashing	X	X	X	X	X	X	X	X
29	113-360 ③	Top Rain Flashing	X	X	X	X	X	X	X	X
30	S552-444-* ①	Filter Door	X	X	X	X	X	X	X	X
30	S552-459 ③	Filter Door	X	X	X	X	X	X	X	X
31	S536-498	Condenser Partition Block-Off Plate	X	X	X	X	X	X	X	X

① Exterior cabinet parts are manufactured with various paint color options. To ensure that you receive the proper paint color, please reference the following codes:
 Beige - X White - 1 Buckeye Gray - 4 Desert Brown - 5 Dark Bronze - 8

③ Note: Exterior cabinet parts are manufactured from stainless steel Code "S"

FUNCTIONAL COMPONENTS

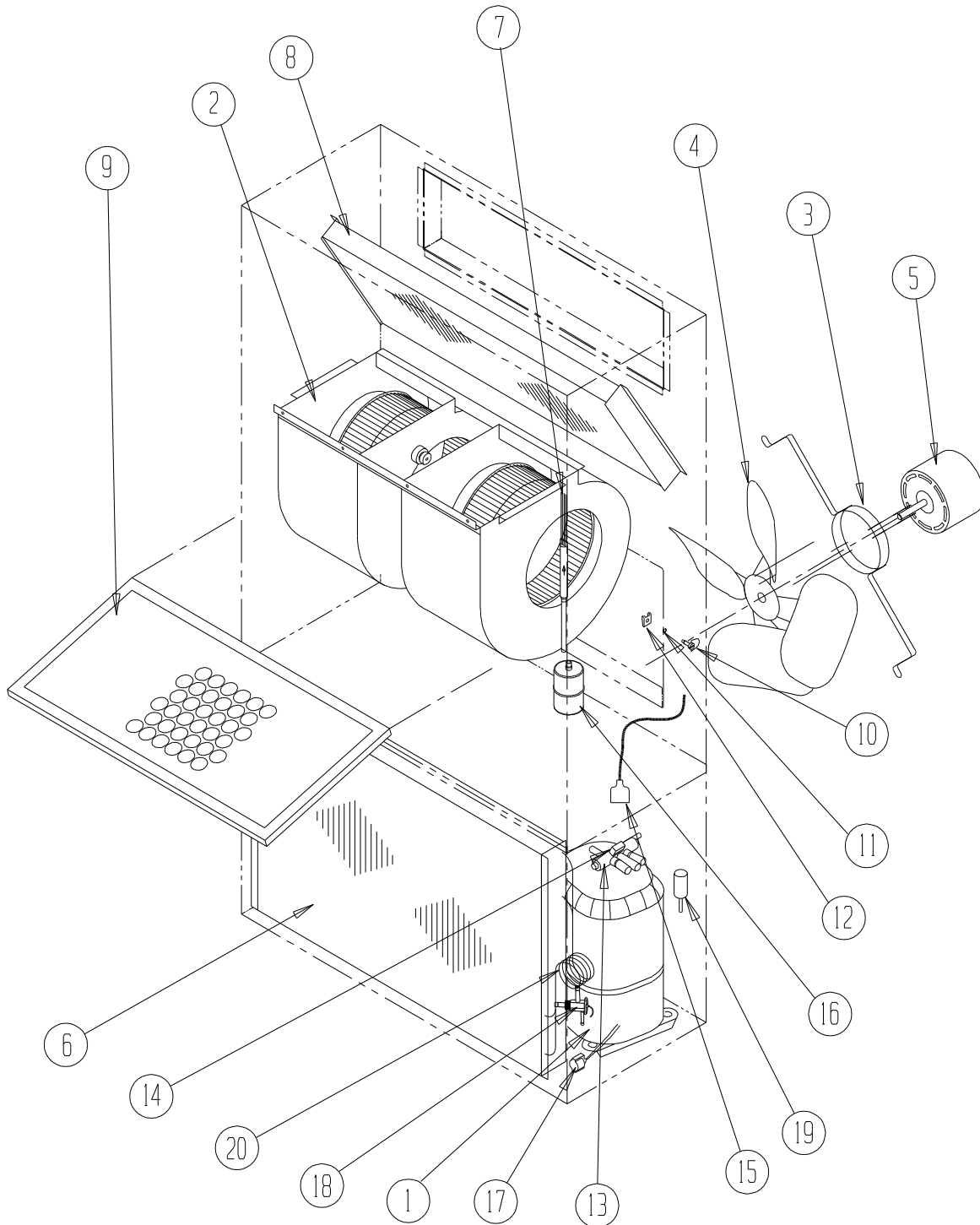

SEXP-529

FUNCTIONAL COMPONENTS

Drawing No.	Part No.	Description	W30H1-A	W30H1-B	W30H1-C	W36H1-A	W36H1-B	W36H1-C
1	8000-298	Compressor	X					
1	8000-299	Compressor		X				
1	8000-300	Compressor			X			
1	8000-309	Compressor				X		
1	8000-310	Compressor					X	
1	8000-311	Compressor						X
2	S900-231	Blower Assembly	X	X		X	X	
2	S900-232	Blower Assembly			X			X
3	8200-001	Fan Motor Mount	X	X	X	X	X	X
4	5151-045	Fan Blade	X	X	X	X	X	X
5	8103-013	Condenser Motor	X	X		X	X	
5	8103-020	Condenser Motor			X			X
6	5051-112BX	Condenser Coil				X	X	X
6	5051-157BX	Condenser Coil	X	X	X			
7	800-0649	Cooling Distributor Assembly				X	X	X
7	800-0357	Cooling Distributor Assembly	X	X	X			
8	5060-064BX	Evaporator Coil	X	X	X			
8	5060-136BX	Evaporator Coil				X	X	X
9	7004-019	Air Filter 1" Throw Away	X	X	X	X	X	X
9	7003-031	Air Filter 1" Washable (Optional)	X	X	X	X	X	X
9	7004-026	Air Filter 2" Pleated (Optional)	X	X	X	X	X	X
10	1171-022	1/4" Turn Fastener	X	X	X	X	X	X
11	1171-024	1/4" Turn Retainer	X	X	X	X	X	X
12	1171-023	1/4" Receptacle	X	X	X	X	X	X
13	5650-039	Reversing Valve w/24V Solenoid Coil	X	X	X	X	X	X
14	5650-042	Rev. Valve Solenoid, Red Casing (Ranco)	X	X	X	X	X	X
14	5650-043	Rev. Valve Solenoid, Black Casing (Wilspec)	X	X	X	X	X	X
14	5650-046	Rev. Valve Solenoid, Black Casing (San Hua)	X	X	X	X	X	X
15	5650-037	Molded Plug 36" Lead	X	X	X	X	X	X
16	5201-009	Filter Drier	X	X	X	X	X	X
17	8620-224	Defrost Sensor	X	X	X	X	X	X
18	5651-177	Heating TXV Thermal Expansion Valve	X	X	X	X	X	X
19	1804-0385	High Pressure Switch (Flare) (Optional)	X	X	X	X	X	X
20	800-0378	Heating Distributor Assembly				X	X	X
20	800-0116	Heating Distributor Assembly	X	X	X			
NS	1804-0385	Low Pressure Switch (Flare) (Optional)	X	X	X	X	X	X
NS	CMA-0116	Low Ambient Control (Flare) (Optional)	X	X	X	X	X	X

NS = Not Shown

FUNCTIONAL COMPONENTS – DEHUM. MODELS

Drawing No.	Part No.	Description	W30H1DA	W30H1DB	W30H1DC	W36H1DA	W36H1DB	W36H1DC
1	8000-298	Compressor	X					
1	8000-299	Compressor		X				
1	8000-300	Compressor			X			
1	8000-309	Compressor				X		
1	8000-310	Compressor					X	
1	8000-311	Compressor						X
2	S900-231	Blower Assembly	X	X		X	X	
2	S900-232	Blower Assembly			X			X
3	8200-001	Fan Motor Mount	X	X	X	X	X	X
4	5151-045	Fan Blade	X	X	X	X	X	X
5	8103-013	Condenser Motor	X	X		X	X	
5	8103-020	Condenser Motor			X			X
6	5051-112BX	Condenser Coil				X	X	X
6	5051-157BX	Condenser Coil	X	X	X			
7	5651-174	Cooling Expansion Valve	X	X	X	X	X	X
7	800-0392	Cooling Distributor Assembly	X	X	X			
7	800-0393	Cooling Distributor Assembly				X	X	X
8	917-0043BX	Evaporator Coil Assembly	X	X	X			
8	917-0123BX	Evaporator Coil Assembly				X	X	X
9	7004-019	Air Filter 1" Throw Away	X	X	X	X	X	X
9	7003-031	Air Filter 1" Washable (Optional)	X	X	X	X	X	X
9	7004-026	Air Filter 2" Pleated (Optional)	X	X	X	X	X	X
10	1171-022	1/4" Turn Fastener	X	X	X	X	X	X
11	1171-024	1/4" Turn Retainer	X	X	X	X	X	X
12	1171-023	1/4" Receptacle	X	X	X	X	X	X
13	5650-039	Reversing Valve w/24V Solenoid Coil	X	X	X	X	X	X
14	5650-042	Rev. Valve Solenoid, Red Casing (Ranco)	X	X	X	X	X	X
14	5650-043	Rev. Valve Solenoid, Black Casing (Wilspec)	X	X	X	X	X	X
14	5650-046	Rev. Valve Solenoid, Black Casing (San Hua)	X	X	X	X	X	X
15	5650-037	Molded Plug 36" Lead	X	X	X	X	X	X
16	5201-009	Filter Drier	X	X	X	X	X	X
17	8620-004	Defrost Sensor	X	X	X	X	X	X
18	5651-004	Heating TXV Thermal Expansion Valve	X	X	X	X	X	X
19	1804-0385	High Pressure Switch (Flare) (Optional)	X	X	X	X	X	X
20	800-0378	Heating Distributor Assembly				X	X	X
20	800-0186	Heating Distributor Assembly	X	X	X			
NS	1804-0107	Low Pressure Switch (Flare) (Optional)	X	X	X	X	X	X
NS	CMA-2	Low Ambient Control (Flare) (Optional)	X	X	X	X	X	X
NS	5650-042	Rev. Valve Solenoid, Red Casing (Ranco)	X	X	X	X	X	X
NS	5650-046	Rev. Valve Solenoid, Black Casing (San Hua)	X	X	X	X	X	X
NS	5650-045	3-Way Valve with 24V Solenoid Coil	X	X	X	X	X	X
NS	5650-043	Flow Control (Orifice)	X	X	X	X	X	X

NS = Not Shown

CONTROL PANEL COMPONENTS

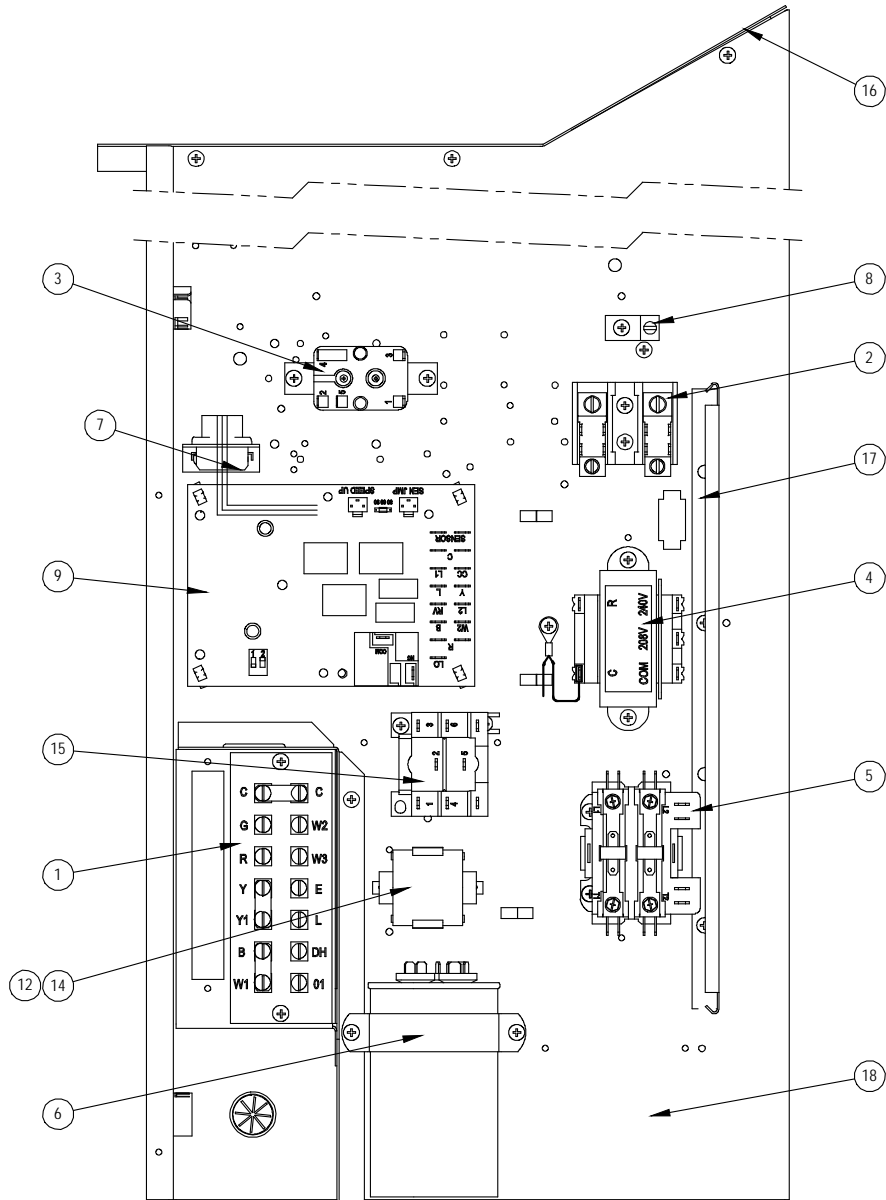

SEXP-530 A

CONTROL PANEL COMPONENTS

Drawing No.	Part No.	Description	W30H1-A	W30H1-B	W30H1-C	W36H1-A	W36H1-B	W36H1-C
1	8607-019	Low Voltage Terminal Strip	X	X	X	X	X	X
2	8607-013	Terminal Block 2 Pole	X			X		
2	8607-014	Terminal Block 3 Pole		X	X		X	X
2	8607-015	Phenolic Insulator			X			X
3	8201-009	Blower Control Relay	X	X		X	X	
3	8201-032	Blower Control Relay			X			X
4	8407-035	Transformer	X	X		X	X	
4	8407-042	Transformer			X			X
5	8401-007	Compressor Contactor	X			X		
5	8401-002	Compressor Contactor		X	X		X	X
6	8552-052	Compressor Capacitor	X			X		
6	8552-002	Outdoor Motor Capacitor		X	X		X	X
7	3000-1284	Wire Assembly	X	X	X	X	X	X
8	8611-006	Ground Terminal	X	X	X	X	X	X
9	8620-223	Heat Pump Control Board	X	X	X	X	X	X
12	8201-086	LAC Bypass Relay ①	X	X	X	X	X	X
14	8551-004	Start Device (PTCR) ①	X			X		
15	8201-032	Outdoor Fan Relay			X			X
16	117X137	Control Panel Top	X	X	X	X	X	X
17	135-122	Wire Shield	X	X	X	X	X	X
18	117X232	Control Panel	X	X	X	X	X	X
NS	4096-140	Wiring Diagram	X			X		
NS	4096-242	Wiring Diagram		X			X	
NS	4096-341	Wiring Diagram			X			X
NS	8201-085	3-Phase Line Monitor		X	X		X	X

NS = Not Shown

① = Optional

CONTROL PANEL COMPONENTS – DEHUM. MODELS

Drawing No.	Part No.	Description	W30H1DA	W30H1DB	W30H1DC	W36H1DA	W36H1DB	W36H1DC
1	8607-019	Low Voltage Terminal Strip	X	X	X	X	X	X
2	8607-013	Terminal Block 2 Pole	X			X		
2	8607-014	Terminal Block 3 Pole		X	X		X	X
2	8607-015	Phenolic Insulator			X			X
3	8201-009	Blower Control Relay	X	X		X	X	
3	8201-032	Blower Control Relay			2			2
4	8407-048	Transformer 65VA	X	X		X	X	
4	8407-050	Transformer 65VA			X			X
5	8401-007	Compressor Contactor	X			X		
5	8401-002	Compressor Contactor		X	X		X	X
6	8552-052	Compressor Capacitor	X			X		
6	8552-002	Outdoor Motor Capacitor		X	X		X	X
7	3000-1285	6 Pin Wire Assembly	X	X	X	X	X	X
8	8611-006	Ground Terminal	X	X	X	X	X	X
9	8620-223	Heat Pump Control Board	X	X	X	X	X	X
10	8201-113	Dehumidification Logic Board	X	X	X	X	X	X
12	8201-086	LAC Bypass Relay ①	X	X	X	X	X	X
13	8607-017	LAC Terminal Block ①	X	X	X	X	X	X
14	8551-004	Start Device (PTCR) ①	X			X		
15	8201-032	Outdoor Fan Relay			X			X
16	117X137	Control Panel Top	X	X	X	X	X	X
17	135-122	Wire Shield	X	X	X	X	X	X
18	117X232	Control Panel	X	X	X	X	X	X
19	8201-085	3-Phase Line Monitor		X	X		X	X
20	8408-037	Return Air Thermostat	X	X	X	X	X	X
NS	4096-143	Wiring Diagram	X			X		
NS	4096-244	Wiring Diagram		X			X	
NS	4096-342	Wiring Diagram			X			X

NS = Not Shown

① = Optional

BLOWER ASSEMBLY

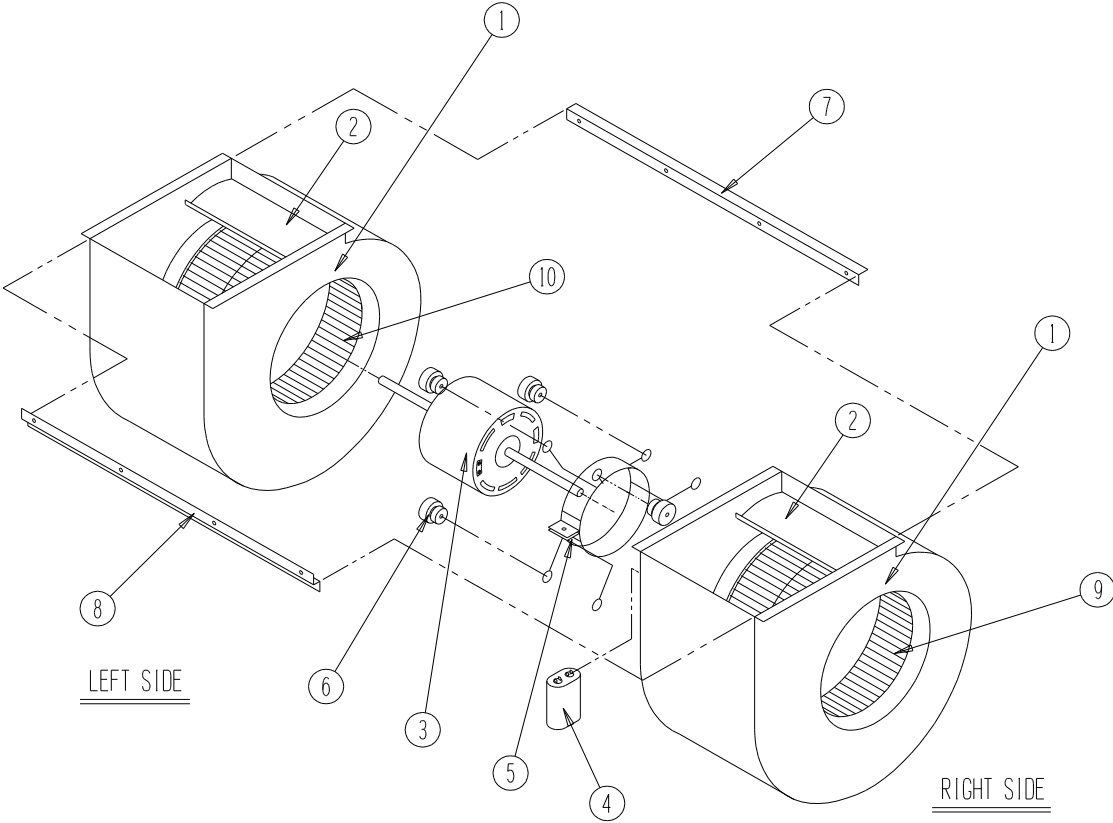

SEXP-346

Drawing No.	Part No.	Description	S900-231	S900-232
1	151-111	Blower Housing	2	2
2	144-174	Diffuser	2	2
3	8105-029	Blower Motor (230/208)	X	
3	8105-033	Blower Motor (460)		X
4	8552-002	Capacitor	X	X
5	8200-031	Motor Mount	X	X
6	5451-011	Grommets	6	6
7	105-870	Back Brace	X	X
8	103-401	Front Brace	X	X
9	5152-090	Wheel CW	X	X
10	5152-091	Wheel CCW	X	X