

---

# REPLACEMENT PARTS MANUAL

---

## WALL MOUNTED PACKAGED HEAT PUMPS

Models:

S38H1-A	S43H1-A	S49H1-A	S61H1-A
S38H1-B	S43H1-B	S49H1-B	S61H1-B
S38H1-C	S43H1-C	S43H1-C	S61H1-C
W38H1-A	W43H1-A	W49H1-A	W61H1-A
W38H1-B	W43H1-B	W49H1-B	W61H1-B
W38H1-C	W43H1-C	W43H1-C	W61H1-C
S38H1DA	S43H1DA	S49H1DA	S61H1DA
S38H1DB	S43H1DB	S49H1DB	S61H1DB
S38H1DC	S43H1DC	S43H1DC	S61H1DC

---

### General Notes

- Revised and/or additional pages may be issued from time to time.
- A complete and current manual consists of pages shown in the following contents section.

### Important

- Contact the installing and/or local Bard distributor for all parts requirements. Be sure to have the complete model and serial number available from the unit rating plate.

### Contents

<u>Description</u>	<u>Page</u>
Cabinet Components	
♦ Exploded View .....	2
♦ Usage List .....	3, 4 & 5
Functional Components	
♦ Exploded View .....	6
♦ Usage List .....	7, 8 & 9
Control Panel Components	
♦ Layout View .....	10
♦ Usage List .....	11
Control Panel Components – Dehum. Models	
♦ Layout View .....	12
♦ Usage List .....	13
Blower Assembly	
♦ Exploded View .....	14
♦ Usage List .....	14



Bard Manufacturing Company, Inc.  
Bryan, Ohio 43506  
www.bardhvac.com

Manual: 2110-578N  
Supersedes: 2110-578M  
Date: 4-18-16

# CABINET COMPONENTS

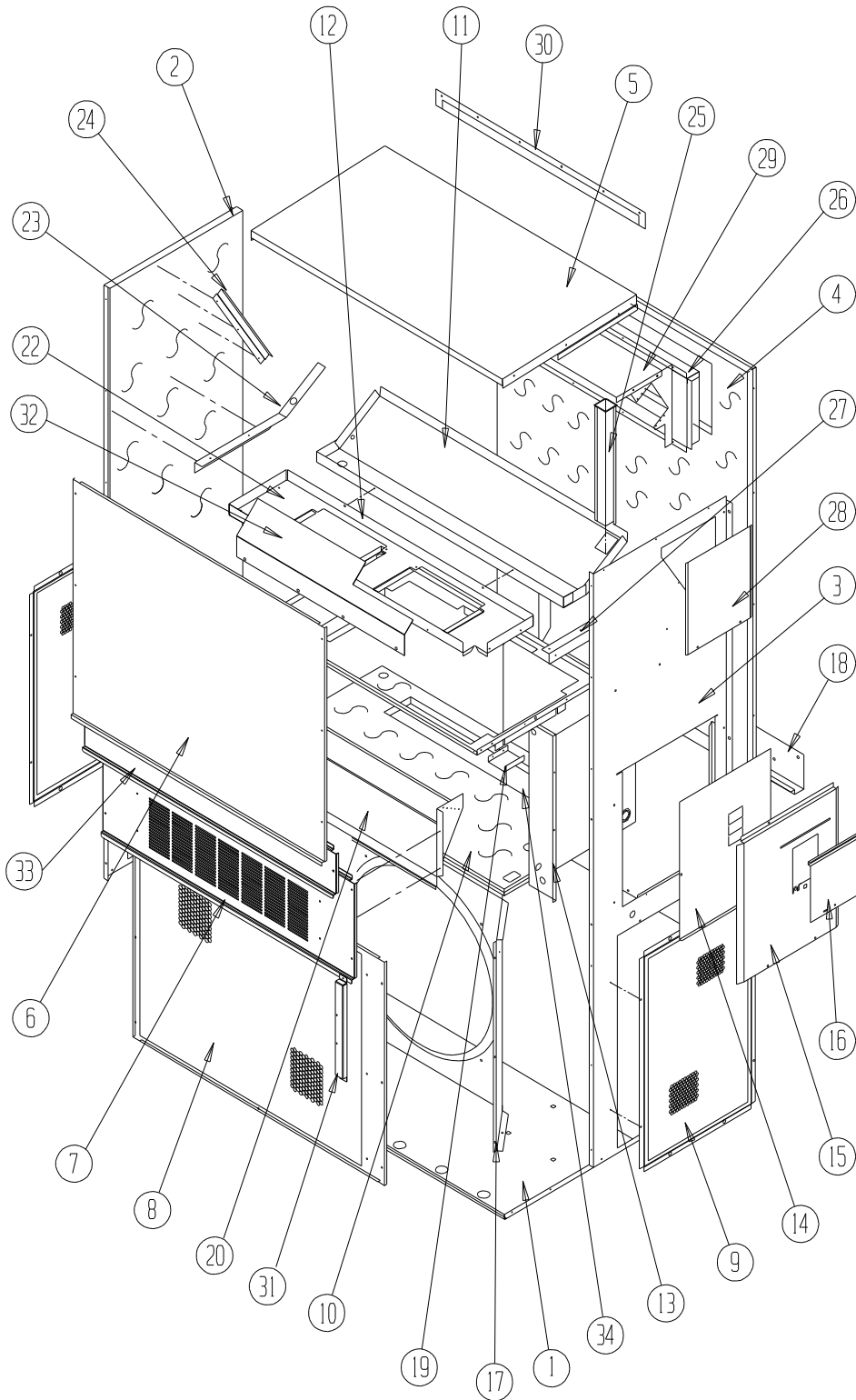

SEXP-545

# CABINET COMPONENTS

Dwg. No.	Part Number	Description	S38H1-A, B	S38H1-C	S43H1-A, B	S43H1-C	S49H1-A, B	S49H1-C	S61H1-A, B	S61H1-C
1	S127X214	Lower Base	X	X	X	X	X	X	X	X
2	S500-262-* ①	Left Side	X	X	X	X	X			
2	S500-316-* ①	Left Side							X	X
3	S500-261-* ①	Right Side	X	X	X	X	X			
3	S500-315-* ①	Right Side							X	X
4	S508-098	Back	X	X	X	X	X			
4	S508-129	Back							X	X
5	S506-142-* ①	Top	X	X	X	X	X	X	X	X
6	S515-144-* ①	Upper Front	X	X	X	X	X	X	X	X
7	S553-383-* ①	Service Door	X	X	X	X	X	X	X	X
8	118-048-* ①	Condenser Grille	X	X	X	X	X			
8	118-052-* ①	Condenser Grille							X	X
9	118-057-* ①	Side Grille	2	2	2	2	2			
9	118-058-* ①	Side Grille							2	2
10	S521X258	Condenser Partition	X	X	X	X	X	X	X	X
11	S123-102	Drain Pan	X	X	X	X	X	X	X	X
12	121X216	Blower Partition	X	X	X	X	X	X	X	X
13	Control Panel Assembly	See Control Panel Assembly Drawing and Parts List Assembly	X	X	X	X	X	X	X	X
14	S132-114	Control Panel Cover (Inner)	X		X		X		X	
14	S132-183	Control Panel Cover (Inner)		X		X		X		X
15	S533-113-* ①	Control Panel Cover (Outer)	X	X	X	X	X	X	X	X
16	S153-218-* ①	Disconnect Access Door	X	X	X	X	X	X	X	X
17	125-024	Fan Shroud	X	X	X	X	X	X		
17	125-029	Fan Shroud							X	X
18	113-140	Bottom Mounting Bracket	X	X	X	X	X	X	X	X
19	137-209	Fill	X	X	X	X	X	X	X	X
20	BFAD-5	Fresh Air Damper Assembly	X	X	X	X	X	X	X	X
22	131X099	Filter Tray	X	X	X	X	X	X	X	X
23	105X877	Left Side Support	X	X	X	X	X	X	X	X
24	147-046	Left Evaporator Support	X	X	X	X	X	X	X	X
25	135-128	Raceway	2	2	2	2	2	2	2	2
26	S111X034	Outlet Air Frame Assembly	X	X	X	X	X	X	X	X
27	105X878	Right Side Support	X	X	X	X	X	X	X	X
28	S143-042-* ①	Right Side Cover Plate (Outer)	X	X	X	X	X	X	X	X
29	135-129	Heat Shield	X	X	X	X	X	X	X	X
30	113-150-* ①	Top Rain Flashing	X	X	X	X	X	X	X	X
32	135-175	Air Baffle	X	X	X	X	X	X	X	X
33	S553-384-* ①	Filter Door Assembly	X	X	X	X	X	X	X	X
34	S536-258	Condenser Part. Blank-Off Plate	X	X	X	X	X	X	X	X

① Exterior cabinet parts are manufactured with various paint color options.  
To ensure the proper paint color is received, please reference the following codes:

Beige	-X	White	-1	Buckeye Gray	-4
Desert Brown	-5	Dark Bronze	-8		

# CABINET COMPONENTS

Dwg. No.	Part Number	Description	W38H1-A, B	W38H1-C	W43H1-A, B	W43H1-C	W49H1-A, B	W49H1-C	W61H1-A, B	W61H1-C
1	S127-299	Lower Base	X	X	X	X	X	X	X	X
2	S500-262-* ①	Left Side	X	X	X	X	X	X		
2	S500-316-* ①	Left Side							X	X
3	S500-261-* ①	Right Side	X	X	X	X	X	X		
3	S500-315-* ①	Right Side							X	X
4	S508-098	Back	X	X	X	X	X	X		
4	S508-129	Back							X	X
5	S506-142-* ①	Top	X	X	X	X	X	X	X	X
6	S515-144-* ①	Upper Front	X	X	X	X	X	X	X	X
7	S553-383-* ①	Service Door	X	X	X	X	X	X	X	X
8	118-054-* ①	Condenser Grille	X	X	X	X	X	X		
8	118-055-* ①	Condenser Grille							X	X
9	118-057-* ①	Side Grille	2	2	2	2	2	2		
9	118-058-* ①	Side Grille							2	2
10	S521X258	Condenser Partition	X	X	X	X	X	X	X	X
11	S123-102	Drain Pan	X	X	X	X	X	X	X	X
12	121X216	Blower Partition	X	X	X	X	X	X	X	X
13	Control Panel Assembly	See Control Panel Assembly Drawing and Parts List Assembly	X	X	X	X	X	X	X	X
14	S132-114	Control Panel Cover (Inner)	X		X		X		X	
14	S132-183	Control Panel Cover (Inner)		X		X		X		X
15	S533-113-* ①	Control Panel Cover (Outer)	X	X	X	X	X	X	X	X
16	S153-322-* ①	Disconnect Access Door	X	X	X	X	X	X	X	X
17	125-036	Fan Shroud	X	X	X	X	X	X		
17	125-038	Fan Shroud							X	X
18	113-140	Bottom Mounting Bracket	X	X	X	X	X	X	X	X
19	137-209	Fill	X	X	X	X	X	X	X	X
20	BFAD-5	Fresh Air Damper Assembly	X	X	X	X	X	X	X	X
22	131X099	Filter Tray	X	X	X	X	X	X	X	X
23	105X877	Left Side Support	X	X	X	X	X	X	X	X
24	147-046	Left Evaporator Support	X	X	X	X	X	X	X	X
25	135-128	Raceway	2	2	2	2	2	2	2	2
26	S111X034	Outlet Air Frame Assembly	X	X	X	X	X	X	X	X
27	105X878	Right Side Support	X	X	X	X	X	X	X	X
28	S143-042-* ①	Right Side Cover Plate (Outer)	X	X	X	X	X	X	X	X
29	135-129	Heat Shield	X	X	X	X	X	X	X	X
30	113-150-* ①	Top Rain Flashing	X	X	X	X	X	X	X	X
31	113-259-* ①	Thermostat Shield	X	X	X	X	X	X	X	X
32	135-175	Air Baffle	X	X	X	X	X	X	X	X
33	S553-384-* ①	Filter Door Assembly	X	X	X	X	X	X	X	X

① Exterior cabinet parts are manufactured with various paint color options.

To ensure the proper paint color is received, please reference the following codes:

Beige	-X	White	-1	Buckeye Gray	-4
Desert Brown	-5	Dark Bronze	-8		

# CABINET COMPONENTS

Dwg. No.	Part Number	Description	S38H1DA, B	S38H1DC	S43H1DA, B	S43H1DC	S49H1DA, B	S49H1DC	S61H1DA, B	S61H1DC
1	S127X214	Lower Base	X	X	X	X	X	X	X	X
2	S500-262-* ①	Left Side	X	X	X	X	X			
2	S500-316-* ①	Left Side							X	X
3	S500-261-* ①	Right Side	X	X	X	X	X	X		
3	S500-315-* ①	Right Side							X	X
4	S508-098	Back	X	X	X	X	X	X		
4	S508-129	Back							X	X
5	S506-142-* ①	Top	X	X	X	X	X	X	X	X
6	S515-144-* ①	Upper Front	X	X	X	X	X	X	X	X
7	S553-383-* ①	Service Door	X	X	X	X	X	X	X	X
8	118-048-* ①	Condenser Grille	X	X	X	X	X	X		
8	118-052-* ①	Condenser Grille							X	X
9	118-057-* ①	Side Grille	2	2	2	2	2	2		
9	118-058-* ①	Side Grille							2	2
10	S521X258	Condenser Partition	X	X	X	X	X	X	X	X
11	S123-102	Drain Pan	X	X	X	X	X	X	X	X
12	121X216	Blower Partition	X	X	X	X	X	X	X	X
13	Control Panel Assembly	See Control Panel Assembly Drawing and Parts List Assembly	X	X	X	X	X	X	X	X
14	S132-114	Control Panel Cover (Inner)	X		X		X		X	
14	S132-183	Control Panel Cover (Inner)		X		X		X		X
15	S533-113-* ①	Control Panel Cover (Outer)	X	X	X	X	X	X	X	X
16	S153-218-* ①	Disconnect Access Door	X	X	X	X	X	X	X	X
17	125-024	Fan Shroud	X	X	X	X	X	X		
17	125-029	Fan Shroud							X	X
18	113-140	Bottom Mounting Bracket	X	X	X	X	X	X	X	X
19	137-209	Fill	X	X	X	X	X	X	X	X
20	BFAD-5	Fresh Air Damper Assembly	X	X	X	X	X	X	X	X
22	131X099	Filter Tray	X	X	X	X	X	X	X	X
23	105X877	Left Side Support	X	X	X	X	X	X	X	X
24	147-046	Left Evaporator Support	X	X	X	X	X	X	X	X
25	135-128	Raceway	2	2	2	2	2	2	2	2
26	S111X034	Outlet Air Frame Assembly	X	X	X	X	X	X	X	X
27	105X878	Right Side Support	X	X	X	X	X	X	X	X
28	S143-042-* ①	Right Side Cover Plate (Outer)	X	X	X	X	X	X	X	X
29	135-129	Heat Shield	X	X	X	X	X	X	X	X
30	113-150-* ①	Top Rain Flashing	X	X	X	X	X	X	X	X
32	135-175	Air Baffle	X	X	X	X	X	X	X	X
33	S553-384-* ①	Filter Door Assembly	X	X	X	X	X	X	X	X
34	S536-258	Condenser Part. Blank-Off Plate	X	X	X	X	X	X	X	X

① Exterior cabinet parts are manufactured with various paint color options.  
To ensure the proper paint color is received, please reference the following codes:

Beige	-X	White	-1	Buckeye Gray	-4
Desert Brown	-5	Dark Bronze	-8		

# FUNCTIONAL COMPONENTS

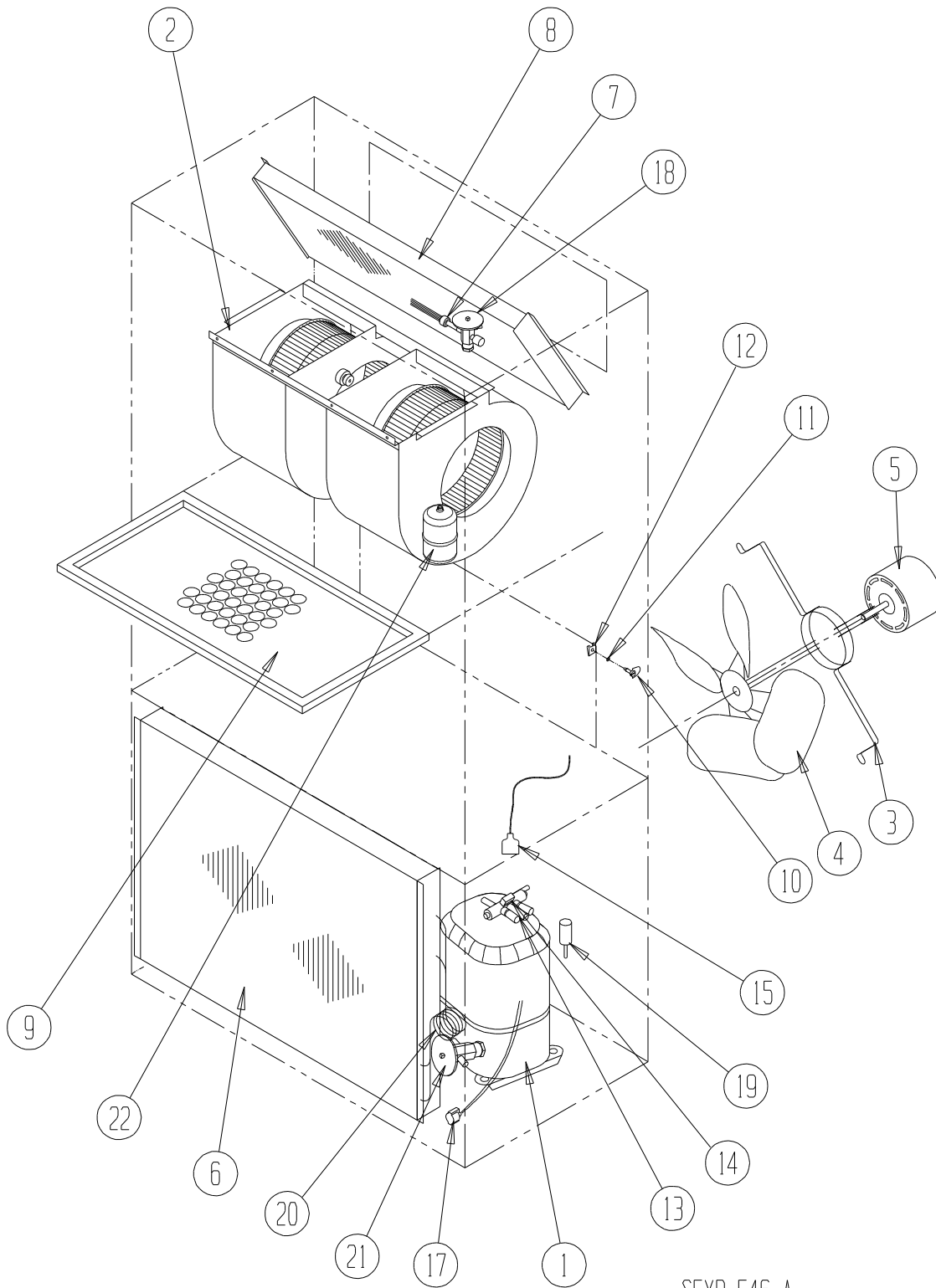

SEXP-546 A

# FUNCTIONAL COMPONENTS

Dwg. No.	Part Number	Description	S38H1-A	S38H1-B	S38H1-C	S43H1-A	S43H1-B	S43H1-C	S49H1-A	S49H1-B	S49H1-C	S61H1-A	S61H1-B	S61H1-C
1	8000-309	Compressor	X											
1	8000-310	Compressor		X										
1	8000-311	Compressor			X									
1	8000-349	Compressor				X								
1	8000-350	Compressor					X							
1	8000-351	Compressor						X						
1	8000-343	Compressor							X					
1	8000-344	Compressor								X				
1	8000-345	Compressor									X			
1	8000-324	Compressor										X		
1	8000-325	Compressor											X	
1	8000-326	Compressor												X
2	S900-272-003	Blower Assembly	X	X	X									
2	S900-273-008	Blower Assembly				X	X	X						
2	S900-273-007	Blower Assembly							X	X	X			
2	S900-273-006	Blower Assembly										X	X	X
3	8200-004	Fan Motor Mount	X	X	X	X	X	X	X	X	X	X	X	X
4	5151-060	Fan Blade	X	X	X	X	X	X	X	X	X	X	X	X
5	8105-039	Condenser Motor	X	X		X	X		X	X		X	X	
5	8105-030	Condenser Motor			X		X				X			X
6	5051-107BX	Condenser Coil	X	X	X	X	X	X						
6	5051-077BX	Condenser Coil							X	X	X			
6	5051-160BX	Condenser Coil										X	X	X
7	800-0342	Cooling Distributor Assembly	X	X	X									
7	800-0287	Cooling Distributor Assembly				X	X	X						
7	800-0288	Cooling Distributor Assembly							X	X	X	X	X	X
8	5060-070BX	Evaporator Coil	X	X	X									
8	5060-138BX	Evaporator Coil				X	X	X						
8	5060-082BX	Evaporator Coil							X	X	X			
8	917-0107BX	Evaporator Coil										X	X	X
9	7004-016	Air Filter 1" Throw Away	X	X	X	X	X	X	X	X	X	X	X	X
9	7003-030	Air Filter 1" Washable ①	X	X	X	X	X	X	X	X	X	X	X	X
9	7004-027	Air Filter 2" Pleated ①	X	X	X	X	X	X	X	X	X	X	X	X
10	1171-022	1/4" Turn Fastener	X	X	X	X	X	X	X	X	X	X	X	X
11	1171-024	1/4" Turn Retainer	X	X	X	X	X	X	X	X	X	X	X	X
12	1171-023	1/4" Receptacle	X	X	X	X	X	X	X	X	X	X	X	X
13	5650-039	Reversing Valve with 24V Solenoid Coil	X	X	X	X	X	X						
13	5650-040	Reversing Valve with 24V Solenoid Coil							X	X	X	X	X	X
14	5650-042	Rev. Valve Solenoid, Red Casing (Ranco)	X	X	X	X	X	X	X	X	X	X	X	X
14	5650-043	Rev. Valve Solenoid, Black Casing (Wilspec)	X	X	X	X	X	X	X	X	X	X	X	X
14	5650-046	Rev. Valve Solenoid, Black Casing (San Hua)	X	X	X	X	X	X	X	X	X	X	X	X
15	5650-037	Molded Plug 36" Lead	X	X	X	X	X	X	X	X	X	X	X	X
17	8620-224	Defrost Sensor	X	X	X	X	X	X	X	X	X	X	X	X
18	5651-225	Expansion Valve Cooling	X	X	X									
18	5651-178	Expansion Valve Cooling				X	X	X						
18	5651-230	Expansion Valve Cooling							X	X	X			
18	5651-199	Expansion Valve Cooling										X	X	X
19	1804-0385	High Pressure Switch (Flare) ①	X	X	X	X	X	X	X	X	X	X	X	X
20	800-0210	Heating Distributor Assembly	X	X	X	X	X	X						
20	800-0399	Heating Distributor Assembly							X	X	X			
20	800-0343	Heating Distributor										X	X	X
21	5651-178	Expansion Valve Heating	X	X	X	X	X	X	X	X	X			
21	5651-184	Expansion Valve Heating										X	X	X
22	5201-010	Filter Drier	X	X	X	X	X	X	X	X	X	X	X	X
NS	1804-0107	Low Pressure Switch (Flare) ①	X	X	X	X	X	X	X	X	X			
NS	CMH-20	Low Ambient Control (Flare) ①	X	X		X	X		X	X				
NS	CMH-21	Low Ambient Control (Flare) ①			X			X			X			
NS	3000-1222	Molded Compressor Plug										X		
NS	3000-1230	Molded Compressor Plug											X	
NS	3000-1224	Molded Compressor Plug	X			X			X					X
NS	3000-1231	Molded Compressor Plug		X	X		X	X		X				

NS – Not Shown      ① – Optional

# FUNCTIONAL COMPONENTS

Dwg. No.	Part Number	Description	W38H1-A	W38H1-B	W38H1-C	W43H1-A	W43H1-B	W43H1-C	W49H1-A	W49H1-B	W49H1-C	W61H1-A	W61H1-B	W61H1-C
1	8000-309	Compressor	X											
1	8000-310	Compressor		X										
1	8000-311	Compressor			X									
1	8000-349	Compressor				X								
1	8000-350	Compressor					X							
1	8000-351	Compressor						X						
1	8000-343	Compressor							X					
1	8000-344	Compressor								X				
1	8000-345	Compressor									X			
1	8000-324	Compressor										X		
1	8000-325	Compressor											X	
1	8000-326	Compressor												X
2	S900-272-003	Blower Assembly	X	X	X									
2	S900-273-008	Blower Assembly				X	X	X						
2	S900-273-007	Blower Assembly							X	X	X			
2	S900-273-006	Blower Assembly										X	X	X
3	8200-004	Fan Motor Mount	X	X	X	X	X	X	X	X	X	X	X	X
4	5151-054	Fan Blade	X	X	X	X	X	X	X	X	X	X	X	X
5	8105-039	Condenser Motor	X	X		X	X		X	X		X	X	
5	8105-030	Condenser Motor			X			X			X			X
6	5051-107BX	Condenser Coil	X	X	X	X	X	X						
6	5051-077BX	Condenser Coil							X	X	X			
6	5051-130BX	Condenser Coil										X	X	X
7	800-0342	Cooling Distributor Assembly	X	X	X									
7	800-0287	Cooling Distributor Assembly				X	X	X						
7	800-0288	Cooling Distributor Assembly							X	X	X	X	X	X
8	5060-070BX	Evaporator Coil	X	X	X									
8	5060-138BX	Evaporator Coil				X	X	X						
8	5060-082BX	Evaporator Coil							X	X	X			
8	917-0107BX	Evaporator Coil										X	X	X
9	7004-016	Air Filter 1" Throw Away	X	X	X	X	X	X	X	X	X	X	X	X
9	7003-030	Air Filter 1" Washable ①	X	X	X	X	X	X	X	X	X	X	X	X
9	7004-027	Air Filter 2" Pleated ①	X	X	X	X	X	X	X	X	X	X	X	X
10	1171-022	1/4" Turn Fastener	X	X	X	X	X	X	X	X	X	X	X	X
11	1171-024	1/4" Turn Retainer	X	X	X	X	X	X	X	X	X	X	X	X
12	1171-023	1/4" Receptacle	X	X	X	X	X	X	X	X	X	X	X	X
13	5650-039	Reversing Valve with 24V Solenoid Coil	X	X	X	X	X	X						
13	5650-040	Reversing Valve with 24V Solenoid Coil							X	X	X	X	X	X
14	5650-042	Rev. Valve Solenoid, Red Casing (Ranco)	X	X	X	X	X	X	X	X	X	X	X	X
14	5650-043	Rev. Valve Solenoid, Black Casing (Wilspec)	X	X	X	X	X	X	X	X	X	X	X	X
14	5650-046	Rev. Valve Solenoid, Black Casing (San Hua)	X	X	X	X	X	X	X	X	X	X	X	X
15	5650-037	Molded Plug 36" Lead	X	X	X	X	X	X	X	X	X	X	X	X
17	8620-224	Defrost Sensor	X	X	X	X	X	X	X	X	X	X	X	X
18	5651-226	Expansion Valve Cooling	X	X	X									
18	5651-178	Expansion Valve Cooling				X	X	X						
18	5651-211	Expansion Valve Cooling							X	X	X			
18	5651-199	Expansion Valve Cooling										X	X	X
19	1804-0385	High Pressure Switch (Flare) ①	X	X	X	X	X	X	X	X	X	X	X	X
20	800-0210	Heating Distributor Assembly	X	X	X	X	X	X						
20	800-0399	Heating Distributor Assembly							X	X	X			
20	800-0343	Heating Distributor										X	X	X
21	5651-178	Expansion Valve Heating	X	X	X	X	X	X	X	X	X			
21	5651-184	Expansion Valve Heating										X	X	X
22	5201-010	Filter Drier	X	X	X	X	X	X	X	X	X	X	X	X
NS	1804-0107	Low Pressure Switch (Flare) ①	X	X	X	X	X	X	X	X	X			
NS	CMH-20	Low Ambient Control (Flare) ①	X	X		X	X		X	X				
NS	CMH-21	Low Ambient Control (Flare) ①			X			X			X			
NS	3000-1222	Molded Compressor Plug										X		
NS	3000-1230	Molded Compressor Plug											X	X
NS	3000-1224	Molded Compressor Plug	X			X			X					
NS	3000-1231	Molded Compressor Plug		X	X		X	X		X				

NS – Not Shown    ① – Optional



# FUNCTIONAL COMPONENTS

Dwg. No.	Part Number	Description	S38H1DA	S38H1DB	S38H1DC	S43H1DA	S43H1DB	S43H1DC	S49H1DA	S49H1DB	S49H1DC	S61H1DA	S61H1DB	S61H1DC
1	8000-309	Compressor	X											
1	8000-310	Compressor		X										
1	8000-311	Compressor			X									
1	8000-349	Compressor				X								
1	8000-350	Compressor					X							
1	8000-351	Compressor						X						
1	8000-343	Compressor							X					
1	8000-344	Compressor								X				
1	8000-345	Compressor									X			
1	8000-324	Compressor										X		
1	8000-325	Compressor											X	
1	8000-326	Compressor												X
2	S900-272-003	Blower Assembly	X	X	X									
2	S900-273-008	Blower Assembly				X	X	X						
2	S900-273-007	Blower Assembly							X	X	X			
2	S900-273-006	Blower Assembly										X	X	X
3	8200-004	Fan Motor Mount	X	X	X	X	X	X	X	X	X	X	X	X
4	5151-060	Fan Blade	X	X	X	X	X	X	X	X	X	X	X	X
5	8105-039	Condenser Motor	X	X		X	X		X	X		X	X	
5	8105-030	Condenser Motor			X			X			X			X
6	5051-107BX	Condenser Coil	X	X	X	X	X	X						
6	5051-077BX	Condenser Coil							X	X	X			
6	5051-130BX	Condenser Coil										X	X	X
7	800-0342	Cooling Distributor Assembly	X	X	X									
7	800-0287	Cooling Distributor Assembly				X	X	X						
7	800-0288	Cooling Distributor Assembly							X	X	X	X	X	X
8	917-0042BX	Evaporator Coil Assembly	X	X	X									
8	917-0130BX	Evaporator Coil Assembly				X	X	X						
8	917-0044BX	Evaporator Coil Assembly							X	X	X			
8	917-0108BX	Evaporator Coil Assembly										X	X	X
9	7004-016	Air Filter 1" Throw Away	X	X	X	X	X	X	X	X	X	X	X	X
9	7003-030	Air Filter 1" Washable ①	X	X	X	X	X	X	X	X	X	X	X	X
9	7004-027	Air Filter 2" Pleated ①	X	X	X	X	X	X	X	X	X	X	X	X
10	1171-022	1/4" Turn Fastener	X	X	X	X	X	X	X	X	X	X	X	X
11	1171-024	1/4" Turn Retainer	X	X	X	X	X	X	X	X	X	X	X	X
12	1171-023	1/4" Receptacle	X	X	X	X	X	X	X	X	X	X	X	X
13	5650-039	Reversing Valve with 24V Solenoid Coil	X	X	X	X	X	X						
13	5650-040	Reversing Valve with 24V Solenoid Coil							X	X	X	X	X	X
14	5650-042	Rev. Valve Solenoid, Red Casing (Ranco)	X	X	X	X	X	X	X	X	X	X	X	X
14	5650-043	Rev. Valve Solenoid, Black Casing (Wilspec)	X	X	X	X	X	X	X	X	X	X	X	X
14	5650-046	Rev. Valve Solenoid, Black Casing (San Hua)	X	X	X	X	X	X	X	X	X	X	X	X
15	5650-037	Molded Plug 36" Lead	X	X	X	X	X	X	X	X	X	X	X	X
17	8620-224	Defrost Sensor	X	X	X	X	X	X	X	X	X	X	X	X
18	5651-225	Expansion Valve Cooling	X	X	X									
18	5651-178	Expansion Valve Cooling				X	X	X						
18	5651-230	Expansion Valve Cooling							X	X	X			
18	5651-199	Expansion Valve Cooling										X	X	X
19	1804-0385	High Pressure Switch (Flare) ①	X	X	X	X	X	X	X	X	X	X	X	X
20	800-0210	Heating Distributor Assembly	X	X	X	X	X	X						
20	800-0399	Heating Distributor Assembly							X	X	X			
20	800-0343	Heating Distributor										X	X	X
21	5651-178	Expansion Valve Heating	X	X	X	X	X	X	X	X	X			
21	5651-184	Expansion Valve Heating										X	X	X
22	5201-010	Filter Drier	X	X	X	X	X	X	X	X	X	X	X	X
NS	1804-0107	Low Pressure Switch (Flare) ①	X	X	X	X	X	X	X	X	X			
NS	CMH-20	Low Ambient Control (Flare) ①	X	X		X	X		X	X				
NS	CMH-21	Low Ambient Control (Flare) ①			X			X			X			
NS	3000-1222	Molded Compressor Plug										X		
NS	3000-1230	Molded Compressor Plug											X	X
NS	3000-1224	Molded Compressor Plug	X			X			X					
NS	3000-1231	Molded Compressor Plug		X	X		X	X		X	X			
NS	5625-043	Flow Control (Orifice)	X	X	X	X	X	X	X	X	X	X	X	X
NS	5650-045	3-Way Vale with 24V Solenoid Coil	X	X	X	X	X	X	X	X	X	X	X	X

NS – Not Shown      ① – Optional

# CONTROL PANEL COMPONENTS

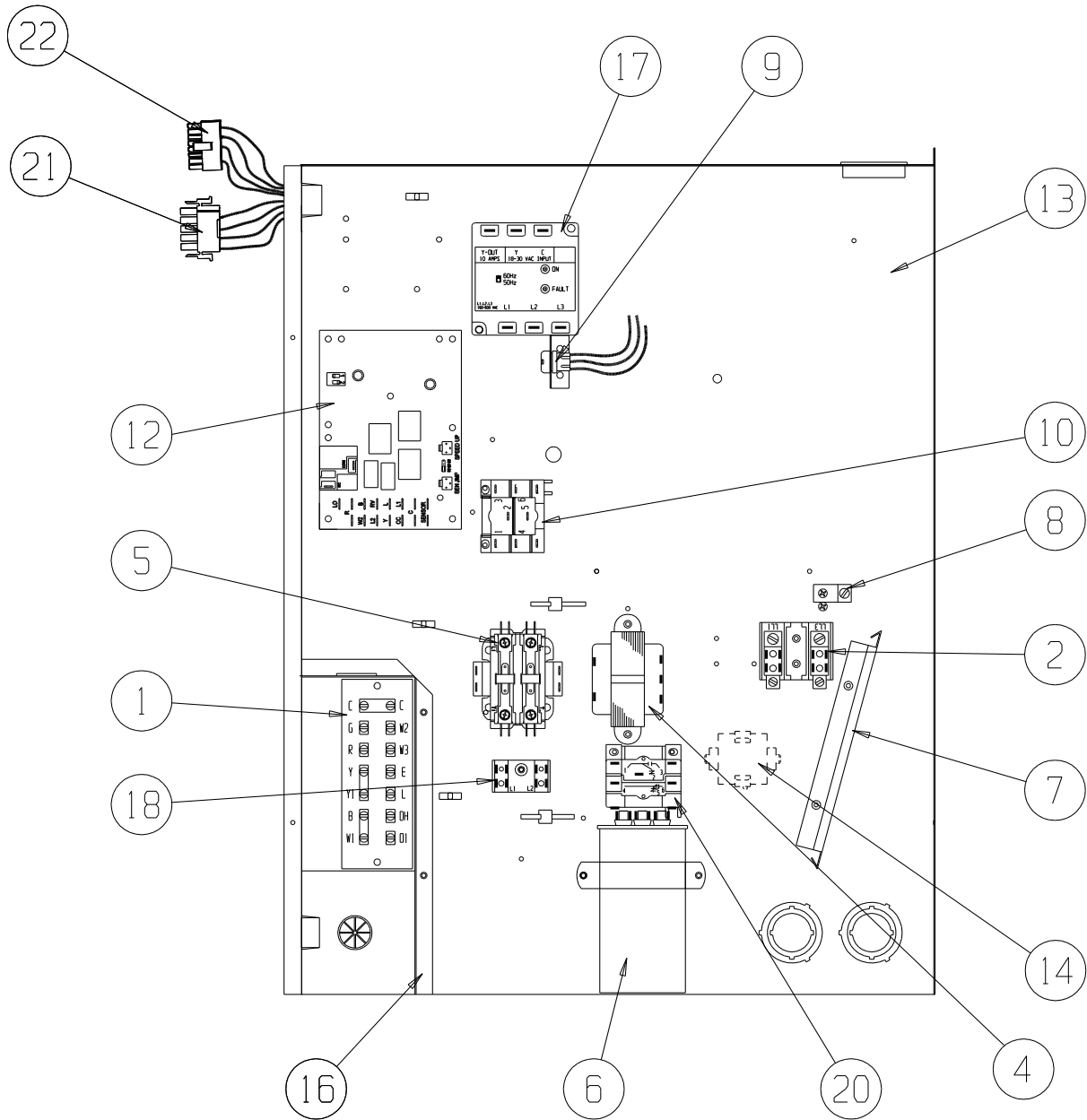

SEXP-551 B

# CONTROL PANEL COMPONENTS

Dwg. No.	Part Number	Description	S38H1-A, W38H1-A	S38H1-B, W38H1-B	S38H1-C, W38H1-C	S43H1-A, W43H1-A	S43H1-B, W43H1-B	S43H1-C, W43H1-C	S49H1-A, W49H1-A	S49H1-B, W49H1-B	S49H1-C, W49H1-C	S61H1-A, W60H1-A	S61H1-B, W60H1-B	S61H1-C, W60H1-C
1	8607-019	Low Voltage Terminal Strip	X	X	X	X	X	X	X	X	X	X	X	X
2	8607-013	Terminal Block 2 Pole	X			X			X			X		
2	8607-014	Terminal Block 3 Pole		X	X		X	X		X	X		X	X
2	8607-015	Phenolic Insulator			X			X			X			X
4	8407-065	Transformer	X	X		X	X		X	X		X	X	
4	8407-042	Transformer			X		X			X	X			X
5	8401-002	Compressor Contactor		X	X		X	X		X	X		X	X
5	8401-025	Compressor Contactor	X			X			X			X		
6	8552-005	Outdoor Motor Capacitor		X			X			X			X	
6	8552-079	Compressor Capacitor	X			X								
6	8552-089	Compressor Capacitor							X					
6	8552-058	Compressor Capacitor									X			
6	8552-026	Compressor Capacitor			X		X				X			X
7	135-130	Wire Shield	X	X	X	X	X	X	X	X	X	X	X	X
8	8611-006	Ground Terminal	X	X	X	X	X	X	X	X	X	X	X	X
9	3000-1324	6 Pin Connector	X	X	X	X	X	X	X	X	X	X	X	X
10	8201-086	Low Ambient Bypass Relay ①	X	X	X	X	X	X	X	X	X	X	X	X
12	1171-023	1/4" Receptacle	X	X	X	X	X	X	X	X	X	X	X	X
13	117-289	Control Panel	X	X	X	X	X	X	X	X	X	X	X	X
14	8551-004	Start Device ① PTCR	X			X			X			X		
16	117X139	Low Voltage Box	X	X	X	X	X	X	X	X	X	X	X	X
17	8201-126	Phase Monitor		X	X		X	X		X	X		X	X
18	8607-017	Terminal Block ①	X	X	X	X	X	X	X	X	X	X	X	X
20	8201-032	Outdoor Fan Relay			X			X			X			X
21	3000-1221	Blower Motor Wire Harness Power	X	X	X	X	X	X	X	X	X	X	X	X
22	3000-1323	Blower Motor Wire Harness Control	X	X	X	X	X	X	X	X	X	X	X	X
NS	4096-149	Wiring Diagram	X			X			X			X		
NS	4096-249	Wiring Diagram		X			X			X			X	
NS	4096-349	Wiring Diagram			X			X			X			X
NS	8615-039	Circuit Breaker 45A 2 Pole (OZ)	X											
NS	8615-040	Circuit Breaker 50A 2 Pole (OZ)				X								
NS	8615-044	Circuit Breaker 35A 3 Pole (OZ)		X			X			X				
NS	8615-041	Circuit Breaker 60A 2 Pole (OZ)										X		
NS	8615-043	Circuit Breaker 40A 3 Pole (OZ)											X	
NS	S8615-068	Rotary Disconnect (OZ)			X		X			X				X
NS	8614-041	Fuse Block			X		X			X				X
NS	8614-046	5A Class CC Fuse			2		2			2				2

NS – Not Shown

① – Optional

# CONTROL PANEL COMPONENTS - DEHUM. MODELS

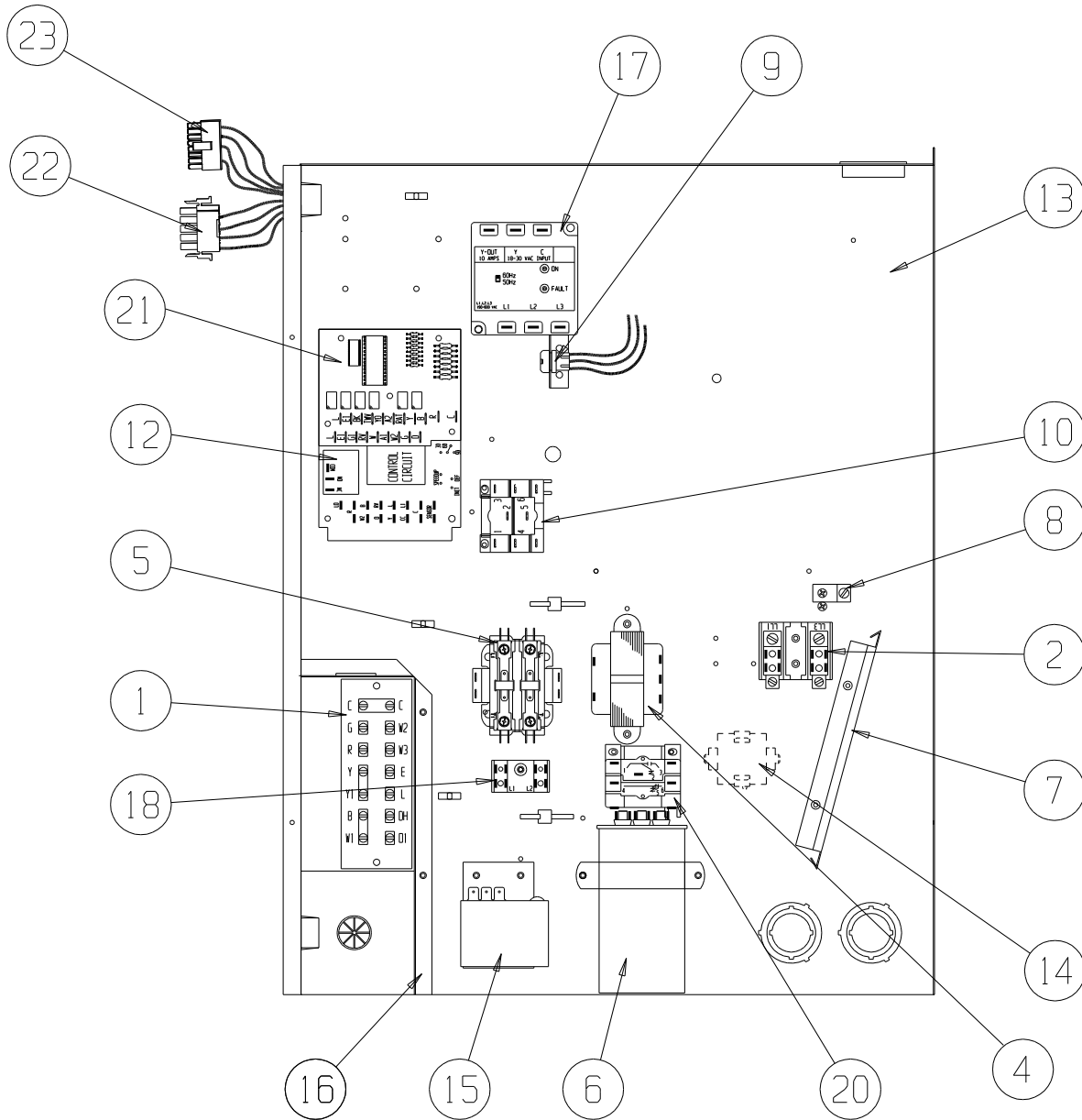

SEXP-552 B

## CONTROL PANEL COMPONENTS – DEHUM. MODELS

Dwg. No.	Part Number	Description	S38H1DA	S38H1DB	S38H1DC	S43H1DA	S43H1DB	S43H1DC	S49H1DA	S49H1DB	S49H1DC	S61H1DA	S61H1DB	S61H1DC
1	8607-019	Low Voltage Terminal Strip	X	X	X	X	X	X	X	X	X	X	X	X
2	8607-013	Terminal Block 2 Pole	X			X			X			X		
2	8607-014	Terminal Block 3 Pole		X	X		X	X		X	X		X	X
2	8607-015	Phenolic Insulator			X			X			X			X
4	8407-065	Transformer	X	X		X	X		X	X		X	X	
4	8407-050	Transformer			X			X			X			X
5	8401-002	Compressor Contactor		X	X		X	X		X	X		X	X
5	8401-025	Compressor Contactor	X			X			X			X		
6	8552-005	Outdoor Motor Capacitor		X	X		X			X			X	
6	8552-079	Compressor Capacitor	X			X								
6	8552-089	Compressor Capacitor							X			X		
6	8552-058	Compressor Capacitor												
6	8552-026	Compressor Capacitor			X			X			X			X
7	135-130	Wire Shield	X	X	X	X	X	X	X	X	X	X	X	X
8	8611-006	Ground Terminal	X	X	X	X	X	X	X	X	X	X	X	X
9	3000-1344	6 Pin Connector	X	X	X	X	X	X	X	X	X	X	X	X
10	8201-086	Low Ambient Bypass Relay ①	X	X	X	X	X	X	X	X	X	X	X	X
12	8620-223	Heat Pump Control Board	X	X	X	X	X	X	X	X	X	X	X	X
13	117-289	Control Panel	X	X	X	X	X	X	X	X	X	X	X	X
14	8551-004	Start Device ① PTCR	X			X			X			X		
15	8408-037	Return Air Thermostat	X	X	X	X	X	X	X	X	X	X	X	X
16	117X139	Low Voltage Box	X	X	X	X	X	X	X	X	X	X	X	X
17	8201-126	Phase Monitor		X	X		X	X		X	X		X	X
18	8607-017	Terminal Block ①	X	X	X	X	X	X	X	X	X	X	X	X
20	8201-032	Outdoor Fan Relay			X						X			X
21	8201-113	Dehumidification Logic Board	X	X	X	X	X	X	X	X	X	X	X	X
22	3000-1221	Blower Motor Wire Harness Power	X	X	X	X	X	X	X	X	X	X	X	X
23	3000-1323	Blower Motor Wire Harness Control	X	X	X	X	X	X	X	X	X	X	X	X
NS	4096-150	Wiring Diagram	X			X			X			X		
NS	4096-250	Wiring Diagram		X			X			X			X	
NS	4096-350	Wiring Diagram			X			X			X			X
NS	8615-039	Circuit Breaker 45A 2 Pole (OZ)	X											
NS	8615-040	Circuit Breaker 50A 2 Pole (OZ)				X			X					
NS	8615-044	Circuit Breaker 35A 3 Pole (OZ)		X			X			X				
NS	8615-041	Circuit Breaker 60A 2 Pole (OZ)										X		
NS	8615-043	Circuit Breaker 40A 3 Pole (OZ)											X	
NS	S8615-068	Rotary Disconnect (OZ)			X			X			X			X
NS	8614-041	Fuse Block			X			X			X			X
NS	8614-046	5A Class CC Fuse			2			2			2			2

NS – Not Shown

① – Optional

# BLOWER ASSEMBLY

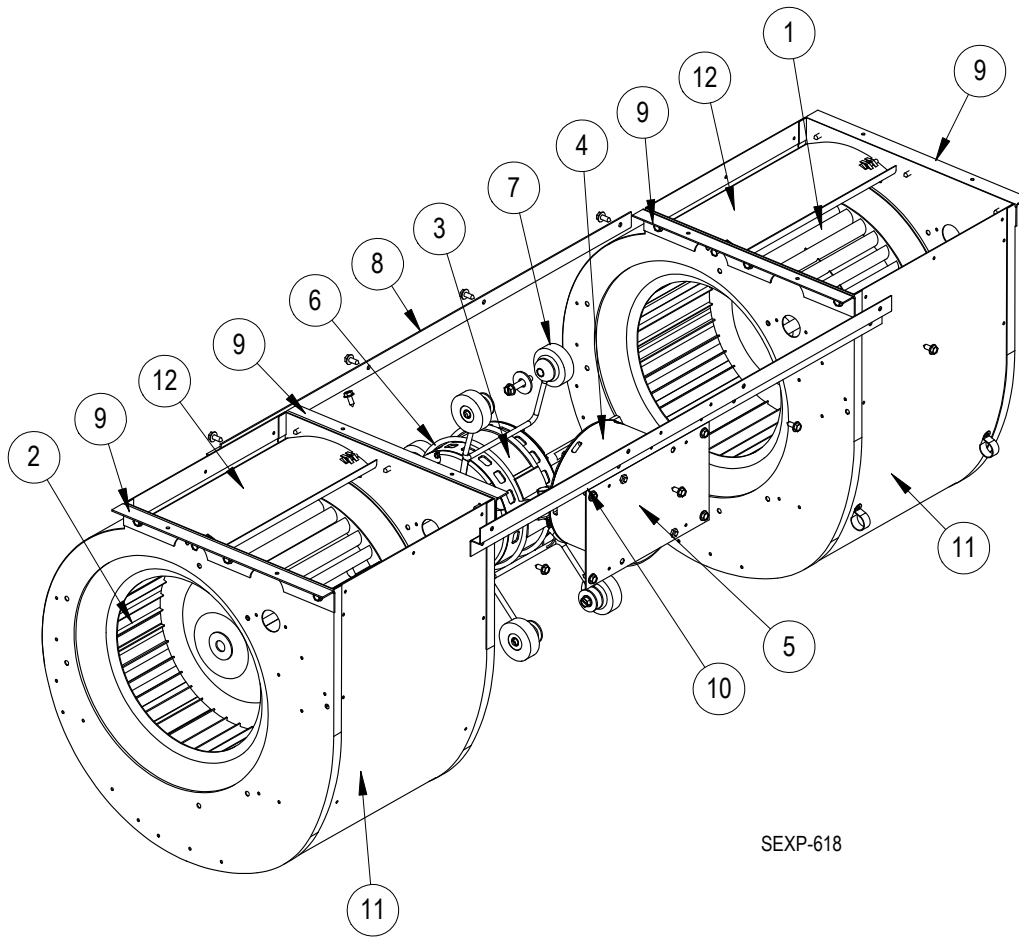

SEXP-618

Dwg. No.	Part Number	Description	S900-272-003	S900-273-008	S900-273-006	S900-273-007
1	5152-011	10-Inch Wheel (CW)	X	X	X	X
2	5152-012	10-Inch Wheel (CCW)	X	X	X	X
3	S8106-052-0065B	1/2 HP Programmed Motor	X			
3	S8107-017-0064A	3/4 HP Programmed Motor		X		
3	S8107-017-0063C	3/4 HP Programmed Motor			X	
3	S8107-017-0070B	3/4 HP Programmed Motor				X
4	C8106-052-0065B	Programmed Motor Control Only	X			
4	C8107-017-0064A	Programmed Motor Control Only		X		
4	C8107-017-0063C	Programmed Motor Control Only			X	
4	C8107-017-0070B	Programmed Motor Control Only				X
5	112-344	Blower Motor Control Bracket	X	X	X	X
6	8200-040	Motor Mount	X	X	X	X
7	5451-011	Grommets	6	6	6	6
8	105-881	Back Brace	X	X	X	X
9	105-880	Side Angle	4	4	4	4
10	103-389	Front Brace	X	X	X	X
11	151-101	Housing	2	2	2	2
12	144-166	Diffuser	2	2	2	2