REPLACEMENT PARTS MANUAL

WALL MOUNTED PACKAGE HEAT PUMPS

Models: **S26H1** **W26H1**
 S31H1 **W31H1**
 S26H1D **S31H1D**

General Notes

- Revised and/or additional pages may be issued from time to time.
- A complete and current manual consists of pages shown in the following contents section.

Important

- Contact the installing and/or local Bard distributor for all parts requirements. Make sure you have the complete model and serial number available from the unit rating plates.

Contents

<i>Description</i>	<i>Page</i>
Cabinet Components	
♦ Exploded View	2
♦ Usage List	3
Functional Components	
♦ Exploded View	4
♦ Usage List	5, 6 & 7
Control Panel	
♦ Layout	8
♦ Usage List	9
Control Panel Components	
♦ Layout	10
♦ Usage List	11
Blower Assembly	
♦ Exploded View	12
♦ Usage List	12



Climate Control Solutions

Bard Manufacturing Company, Inc.
Bryan, Ohio 43506
Since 1914...Moving ahead, just as planned.

Manual: 2110-579C
Supersedes: 2110-579B
File: Tab 17
Date: 06-11-14

CABINET COMPONENTS

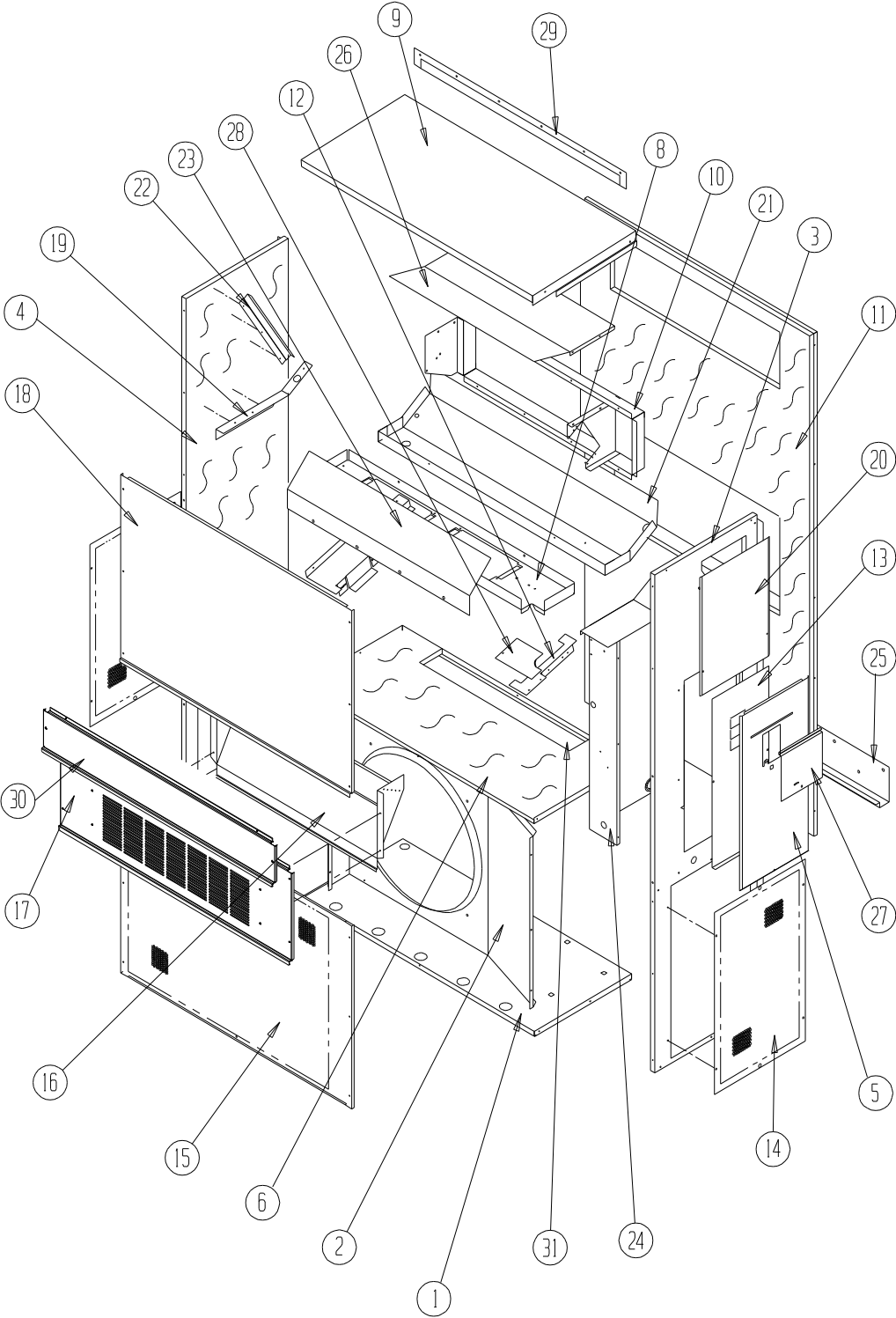

SEXP-514 A

CABINET COMPONENTS

Dwg. No.	Part Number	Description	S26H1-A, -B S31H1-A, -B	S26H1-C S31H1-C	W26H1-A, -B W31H1-A, -B	W26H1-C W31H1-C	S26H1DA, DB S31H1DA, DB	S26H1DC S31H1DC
1	S127-199	Lower Base	X	X	X	X	X	X
2	125-022	Fan Shroud	X	X			X	X
2	125-028	Fan Shroud			X	X		
3	S500-228-* ①	Right Side	X	X	X	X	X	X
4	S500-229-* ①	Left Side	X	X	X	X	X	X
5	S533-109-* ①	Control Panel Cover (Outer)	X	X	X	X	X	X
6	S521X384	Condenser Partition	X	X	X	X	X	X
8	121X182	Blower Partition	X	X	X	X	X	X
9	S506-130-* ①	Top	X	X	X	X	X	X
10	S111X030	Outlet Airframe Assembly	X	X	X	X	X	X
11	S508-088	Back	X	X	X	X	X	X
12	113X195	Filter Bracket	2	2	2	2	2	2
13	S132-104	Control Panel Cover	X		X		X	
13	S132-172	Control Panel Cover		X		X		X
14	118-056-* ①	Side Grille	2	2	2	2	2	2
15	118-059-* ①	Condenser Grille	X	X	X	X	X	X
16	BFAD-3	Fresh Air Damper Assembly	X	X	X	X	X	X
17	S552-206-* ①	Service Door	X	X	X	X	X	X
18	S514-160-* ①	Upper Front	X	X	X	X	X	X
19	105X850	Left Side Support	X	X	X	X	X	X
20	S143-034-* ①	Right Side Cover Plate (Outer)	X	X	X	X	X	X
21	S123-078	Drain Pan	X	X	X	X	X	X
22	147-044	Left Evaporator Support	X	X	X	X	X	X
24	Control Panel Assembly	See Control Panel Assembly Drawing and Parts List	X	X	X	X	X	X
25	113-140	Bottom Mounting Bracket	X	X	X	X	X	X
26	135X123	Heat Shield	X	X	X	X	X	X
27	S153-218-* ①	Disconnect Access Door	X	X	X	X	X	X
28	137-259	Fill Plate	X	X	X	X	X	X
29	113-149-* ①	Top Rain Flashing	X	X	X	X	X	X
30	S552-444-* ①	Filter Door Assembly	X	X	X	X	X	X
31	S536-498-* ①	Condenser Part. Block-Off Plate	X	X	X	X	X	X

① Exterior cabinet parts are manufactured with various paint color options. To ensure that you receive the proper paint color, please reference the following codes:

Beige	-X	White	-1
Desert Brown	-5	Dark Bronze	-8
		Buckeye Gray	-4

FUNCTIONAL COMPONENTS

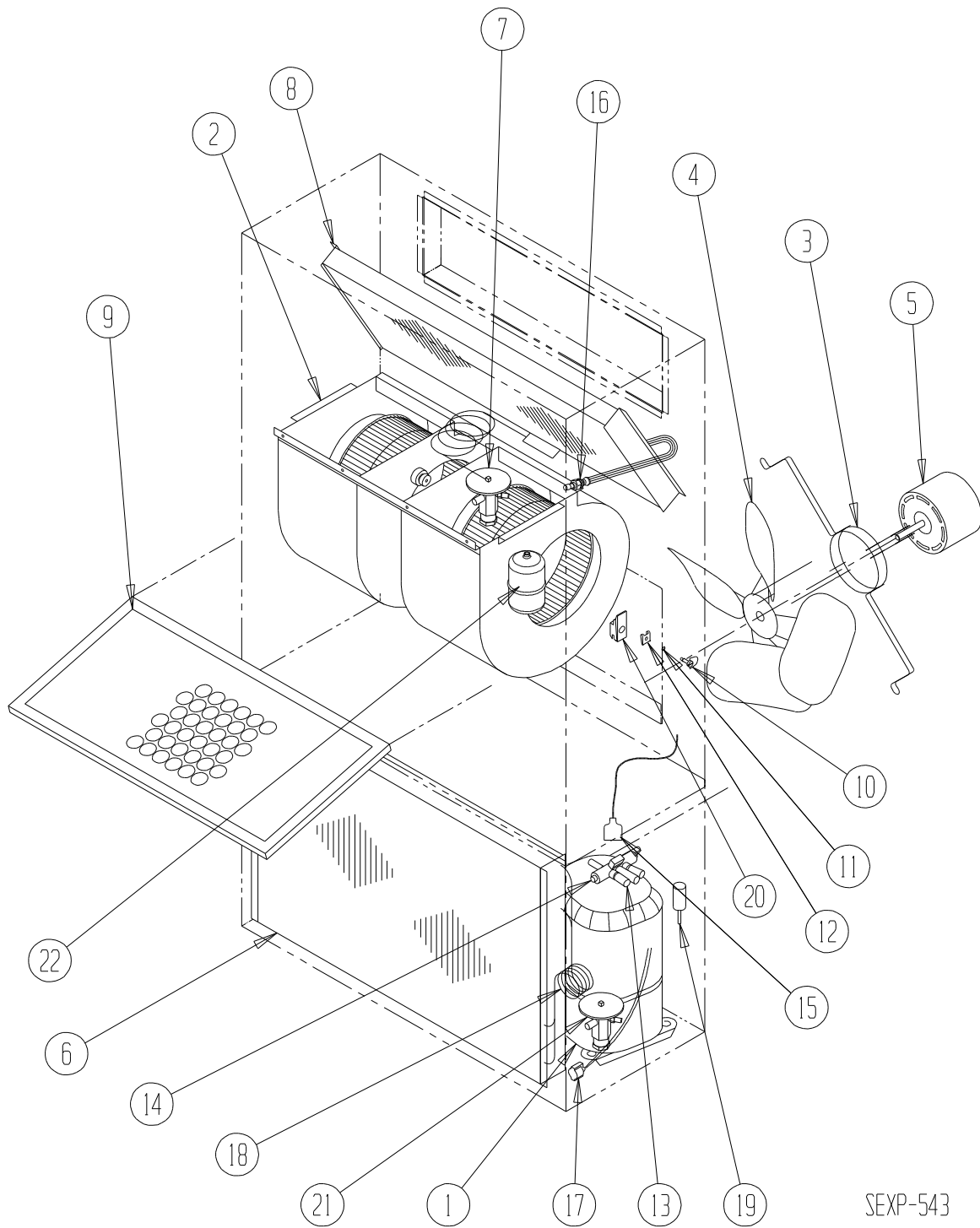

SEXP-543

FUNCTIONAL COMPONENTS

Dwg. No.	Part Number	Description	S26H1-A	S26H1-B	S26H1-C	S31H1-A	S31H1-B	S31H1-C
1	8000-314	Compressor	X					
1	8000-315	Compressor		X				
1	8000-316	Compressor			X			
1	8000-346	Compressor				X		
1	8000-347	Compressor					X	
1	8000-348	Compressor						X
2	S900-246	Blower Assembly	X	X		X	X	
2	S900-247	Blower Assembly			X			X
3	8200-001	Fan Motor Mount	X	X	X	X	X	X
4	5151-045	Fan Blade	X	X	X	X	X	X
5	8103-013	Condenser Motor	X	X		X	X	
5	8103-020	Condenser Motor			X			X
6	5051-112BX	Condenser Coil	X	X	X	X	X	X
7	5651-191	Cooling TXV	X	X	X			
7	5651-200	Cooling TXV				X	X	X
8	5060-101BX	Evaporator Coil	X	X	X			
8	5060-064BX	Evaporator Coil				X	X	X
9	7004-019	Air Filter 1" Throw-Away	X	X	X	X	X	X
9	7003-031	Air Filter 1" Washable ①	X	X	X	X	X	X
9	7004-026	Air Filter 2" Pleated ①	X	X	X	X	X	X
10	1171-022	1/4 Turn Fastener	X	X	X	X	X	X
11	1171-024	1/4 Turn Retainer	X	X	X	X	X	X
12	1171-023	1/4 Receptacle	X	X	X	X	X	X
13	5650-039	Reversing Valve with 24VSolenoid Coil	X	X	X	X	X	X
14	5650-042	Rev. Valve Solenoid, Red Casing (Ranco)	X	X	X	X	X	X
14	5650-043	Rev. Valve Solenoid, Black Casing (Wilspec)	X	X	X	X	X	X
14	5650-046	Rev. Valve Solenoid, Black Casing (San Hua)	X	X	X	X	X	X
15	5650-037	Molded Plug 3/6" Lead	X	X	X	X	X	X
16	800-0292	Cooling Distributor	X	X	X	X	X	X
17	8620-224	Defrost Sensor	X	X	X	X	X	X
18	800-0403	Heating Distributor	X	X	X	X	X	X
19	1804-0385	High Pressure Switch (Flare) ①	X	X	X	X	X	X
21	5651-191	Heating TXV	X	X	X			
21	5651-200	Heating TXV				X	X	X
22	5201-009	Filter Drier (Bi-Direct)	X	X	X	X	X	X
NS	1804-0107	Low Pressure Switch (Flare) ①	X	X	X	X	X	X
NS	CMH-20	Low Ambient Control (Flare) ①	X	X		X	X	
NS	CMH-21	Low Ambient Control (Flare) ①			X			X
NS	3000-1244	Molded Compressor Plug		X	X		X	X
NS	3000-1276	Molded Compressor Plug	X			X		

NS – Not Shown

① – Optional

FUNCTIONAL COMPONENTS

Dwg. No.	Part Number	Description	W26H1-A	W26H1-B	W26H1-C	W31H1-A	W31H1-B	W31H1-C
1	8000-314	Compressor	X					
1	8000-315	Compressor		X				
1	8000-316	Compressor			X			
1	8000-346	Compressor				X		
1	8000-347	Compressor					X	
1	8000-348	Compressor						X
2	S900-246	Blower Assembly	X	X		X	X	
2	S900-247	Blower Assembly			X			X
3	8200-001	Fan Motor Mount	X	X	X	X	X	X
4	5151-050	Fan Blade	X	X	X	X	X	X
5	8103-013	Condenser Motor	X	X		X	X	
5	8103-020	Condenser Motor			X			X
6	5051-164BX	Condenser Coil	X	X	X	X	X	X
7	5651-191	Cooling TXV	X	X	X			
7	5651-200	Cooling TXV				X	X	X
8	5060-101BX	Evaporator Coil	X	X	X			
8	5060-064BX	Evaporator Coil				X	X	X
9	7004-019	Air Filter 1" Throw-Away	X	X	X	X	X	X
9	7003-031	Air Filter 1" Washable ①	X	X	X	X	X	X
9	7004-026	Air Filter 2" Pleated ①	X	X	X	X	X	X
10	1171-022	1/4 Turn Fastener	X	X	X	X	X	X
11	1171-024	1/4 Turn Retainer	X	X	X	X	X	X
12	1171-023	1/4 Receptacle	X	X	X	X	X	X
13	5650-039	Reversing Valve with 24VSolenoid Coil	X	X	X	X	X	X
14	5650-042	Rev. Valve Solenoid, Red Casing (Ranco)	X	X	X	X	X	X
14	5650-043	Rev. Valve Solenoid, Black Casing (Wilspec)	X	X	X	X	X	X
14	5650-046	Rev. Valve Solenoid, Black Casing (San Hua)	X	X	X	X	X	X
15	5650-037	Molded Plug 36" Lead	X	X	X	X	X	X
16	800-0292	Cooling Distributor	X	X	X	X	X	X
17	8620-224	Defrost Sensor	X	X	X	X	X	X
18	800-0403	Heating Distributor	X	X	X	X	X	X
19	1804-0385	High Pressure Switch (Flare) ①	X	X	X	X	X	X
21	5651-191	Heating TXV	X	X	X			
21	5651-200	Heating TXV				X	X	X
22	5201-009	Filter Drier (Bi-Direct)	X	X	X	X	X	X
NS	1804-0107	Low Pressure Switch (Flare) ①	X	X	X	X	X	X
NS	CMH-20	Low Ambient Control (Flare) ①	X	X		X	X	
NS	CMH-21	Low Ambient Control (Flare) ①			X			X
NS	3000-1244	Molded Compressor Plug		X	X		X	X
NS	3000-1276	Molded Compressor Plug	X			X		

NS – Not Shown

① – Optional

FUNCTIONAL COMPONENTS

Dwg. No.	Part Number	Description	S26H1DA	S26H1DB	S26H1DC	S31H1DA	S31H1DB	S31H1DC
1	8000-314	Compressor	X					
1	8000-315	Compressor		X				
1	8000-316	Compressor			X			
1	8000-346	Compressor				X		
1	8000-347	Compressor					X	
1	8000-348	Compressor						X
2	S900-246	Blower Assembly	X	X		X	X	
2	S900-247	Blower Assembly			X			X
3	8200-001	Fan Motor Mount	X	X	X	X	X	X
4	5151-045	Fan Blade	X	X	X	X	X	X
5	8103-013	Condenser Motor	X	X		X	X	
5	8103-020	Condenser Motor			X			X
6	5051-112BX	Condenser Coil	X	X	X	X	X	X
7	5651-191	Cooling TXV	X	X	X			
7	5651-200	Cooling TXV				X	X	X
8	917-0075BX	Evaporator Coil	X	X	X			
8	917-0043BX	Evaporator Coil				X	X	X
9	7004-019	Air Filter 1" Throw-Away	X	X	X	X	X	X
9	7003-031	Air Filter 1" Washable ①	X	X	X	X	X	X
9	7004-026	Air Filter 2" Pleated ①	X	X	X	X	X	X
10	1171-022	1/4 Turn Fastener	X	X	X	X	X	X
11	1171-024	1/4 Turn Retainer	X	X	X	X	X	X
12	1171-023	1/4 Receptacle	X	X	X	X	X	X
13	5650-039	Reversing Valve with 24V Solenoid Coil	X	X	X	X	X	X
14	5650-042	Rev. Valve Solenoid, Red Casing (Ranco)	X	X	X	X	X	X
14	5650-043	Rev. Valve Solenoid, Black Casing (Wilspec)	X	X	X	X	X	X
14	5650-046	Rev. Valve Solenoid, Black Casing (San Hua)	X	X	X	X	X	X
15	5650-037	Molded Plug 3/8" Lead	X	X	X	X	X	X
16	800-0292	Cooling Distributor	X	X	X	X	X	X
17	8620-224	Defrost Sensor	X	X	X	X	X	X
18	800-0403	Heating Distributor	X	X	X	X	X	X
19	1804-0385	High Pressure Switch (Flare) ①	X	X	X	X	X	X
21	5651-191	Heating TXV	X	X	X			
21	5651-200	Heating TXV				X	X	X
22	5201-009	Filter Drier (Bi-Direct)	X	X	X	X	X	X
NS	1804-0107	Low Pressure Switch (Flare) ①	X	X	X	X	X	X
NS	CMH-20	Low Ambient Control (Flare) ①	X	X		X	X	
NS	CMH-21	Low Ambient Control (Flare) ①			X			X
NS	3000-1244	Molded Compressor Plug		X	X		X	X
NS	3000-1276	Molded Compressor Plug	X			X		
NS	5625-043	Flow Control (Orifice)	X	X	X	X	X	X
NS	5650-045	3-Way Valve with 24V Solenoid Coil	X	X	X	X	X	X

NS – Not Shown

① – Optional

CONTROL PANEL

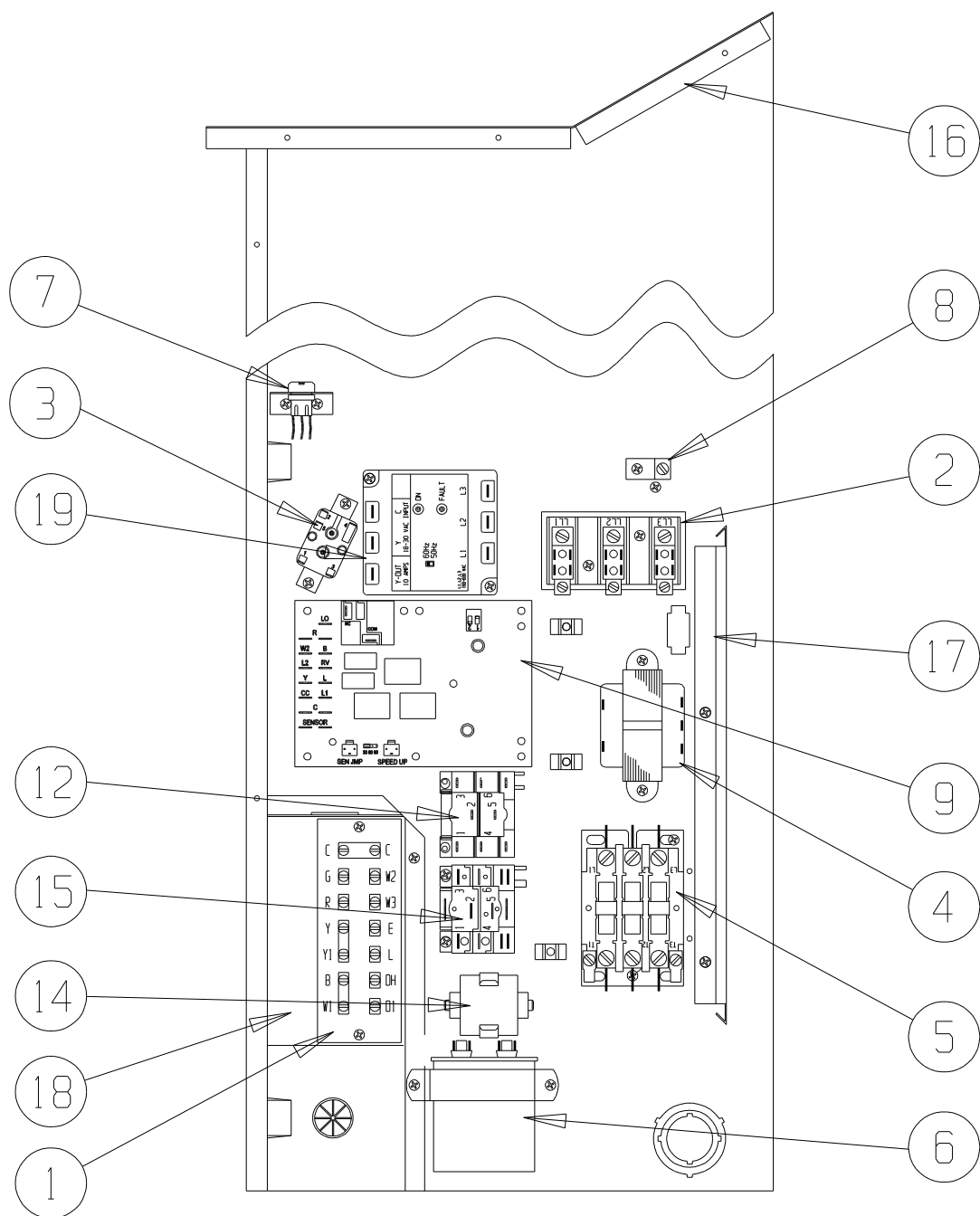

SEXP-544

CONTROL PANEL

Dwg. No.	Part Number	Description	S26H1-A, W26H1-A	S26H1-B, W26H1-B	S26H1-C, W26H1-C	S31H1-A, W31H1-A	S31H1-B, W31H1-B	S31H1-C, W31H1-C
1	8607-019	Low Voltage Terminal Strip	X	X	X	X	X	X
2	8607-013	Terminal Block 2 Pole	X			X		
2	8607-014	Terminal Block 3 Pole		X	X		X	X
2	8607-015	Phenolic Insulator			X			X
3	8201-009	Blower Control Relay	X	X		X	X	
3	8201-032	Blower Control Relay			X			X
4	8407-035	Transformer	X	X		X	X	
4	8407-042	Transformer			X			X
5	8401-007	Compressor Contactor	X			X		
5	8401-002	Compressor Contactor		X	X		X	X
6	8552-050	Compressor Capacitor	X					
6	8552-052	Compressor Capacitor				X		
6	8552-002	Outdoor Motor Capacitor		X	X		X	X
7	3000-1284	6 Pin Connector	X	X	X	X	X	X
8	8611-006	Ground Terminal	X	X	X	X	X	X
9	8620-223	Heat Pump Control Board w/LPB	X	X	X	X	X	X
12	8201-032	Outdoor Fan Relay			X			X
14	8551-004	Start Device ① (PTCR)	X			X		
15	8201-086	LAC Bypass Relay ①	X	X	X	X	X	X
16	117X137	Control Panel Top	X	X	X	X	X	X
17	135-122	Wire Shield	X	X	X	X	X	X
18	117X232	Control Panel	X	X	X	X	X	X
19	8201-085	Phase Monitor		X	X		X	X
NS	4096-140	Wiring Diagram	X			X		
NS	4096-242	Wiring Diagram		X			X	
NS	4096-341	Wiring Diagram			X			X
NS	8615-037	Circuit Breaker 30A 2 Pole (0Z)	X					
NS	8615-051	Circuit Breaker 25A 3 Pole (0Z)		X			X	
NS	8615-038	Circuit Breaker 35A 2 Pole (0Z)				X		
NS	S8615-068	Rotary Disconnect (0Z)			X			X

NS – Not Shown

① – Optional

CONTROL PANEL COMPONENTS

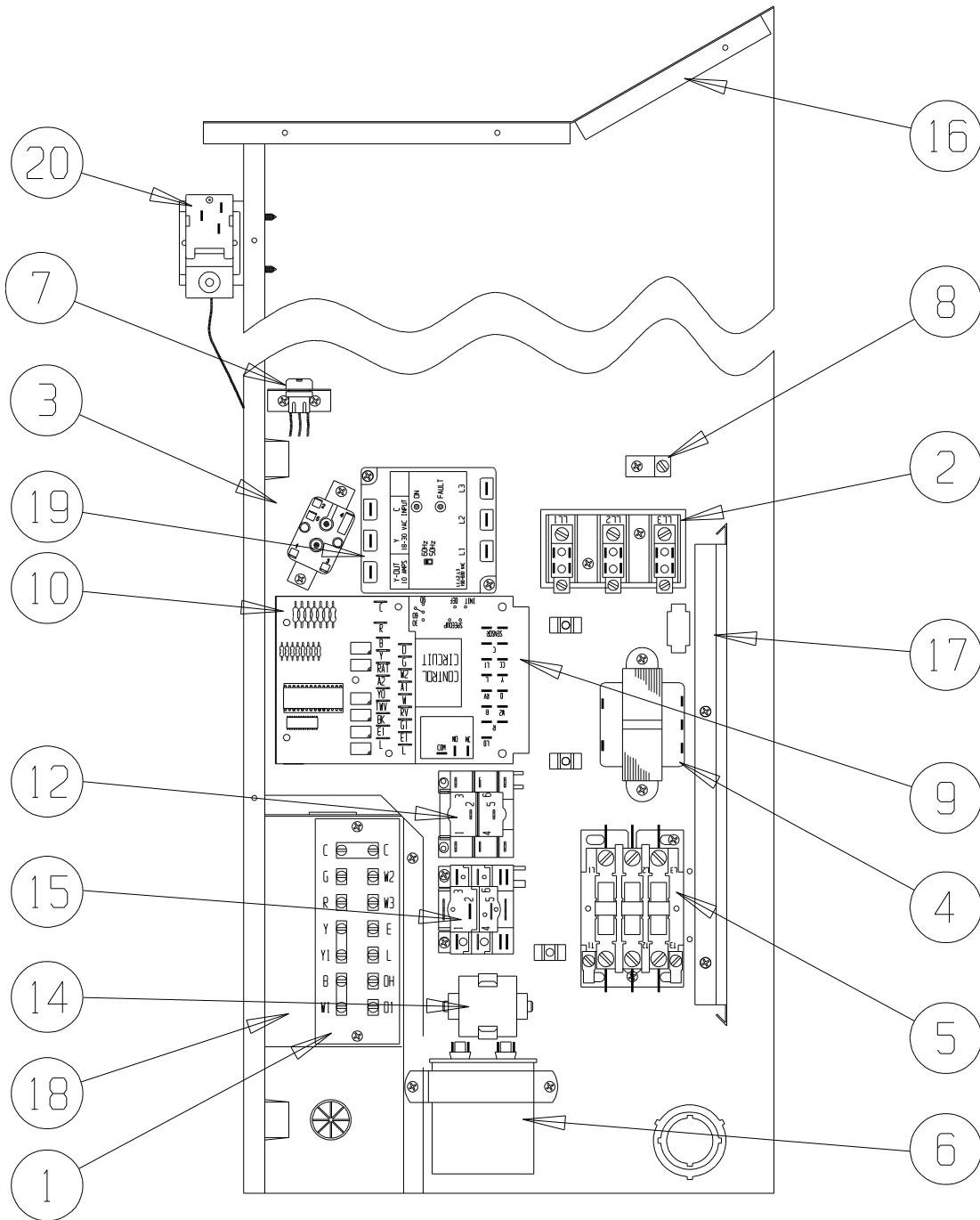

SEXP-553

CONTROL PANEL

Dwg. No.	Part Number	Description	S26H1DA	S26H1DB	S26H1DC	S31H1DA	S31H1DB	S31H1DC
1	8607-019	Low Voltage Terminal Strip	X	X	X	X	X	X
2	8607-013	Terminal Block 2 Pole	X			X		
2	8607-014	Terminal Block 3 Pole		X	X		X	X
2	8607-015	Phenolic Insulator			X			X
3	8201-009	Blower Control Relay	X	X		X	X	
3	8201-032	Blower Control Relay			X			X
4	8407-035	Transformer	X	X		X	X	
4	8407-042	Transformer			X			X
5	8401-007	Compressor Contactor	X			X		
5	8401-002	Compressor Contactor		X	X		X	X
6	8552-050	Compressor Capacitor	X					
6	8552-052	Compressor Capacitor				X		
6	8552-002	Outdoor Motor Capacitor		X	X		X	X
7	3000-1285	6 Pin Connector	X	X	X	X	X	X
8	8611-006	Ground Terminal	X	X	X	X	X	X
9	8620-223	Heat Pump Control Board w/LPB	X	X	X	X	X	X
10	8201-113	Dehumidification Logic Board	X	X	X	X	X	X
12	8201-032	Outdoor Fan Relay			X			X
14	8551-004	Start Device ① (PTCR)	X			X		
15	8201-086	LAC Bypass Relay ①	X	X	X	X	X	X
16	117X137	Control Panel Top	X	X	X	X	X	X
17	135-122	Wire Shield	X	X	X	X	X	X
18	117X232	Control Panel	X	X	X	X	X	X
19	8201-085	Phase Monitor		X	X		X	X
20	8408-037	Return Air Thermostat	X	X	X	X	X	X
NS	4096-151	Wiring Diagram	X			X		
NS	4096-251	Wiring Diagram		X			X	
NS	4096-351	Wiring Diagram			X			X
NS	8615-037	Circuit Breaker 30A 2 Pole (0Z)	X					
NS	8615-051	Circuit Breaker 25A 3 Pole (0Z)		X			X	
NS	8615-038	Circuit Breaker 35A 2 Pole (0Z)				X		
NS	S8615-068	Rotary Disconnect (0Z)			X			X

NS – Not Shown

① – Optional

BLOWER ASSEMBLY

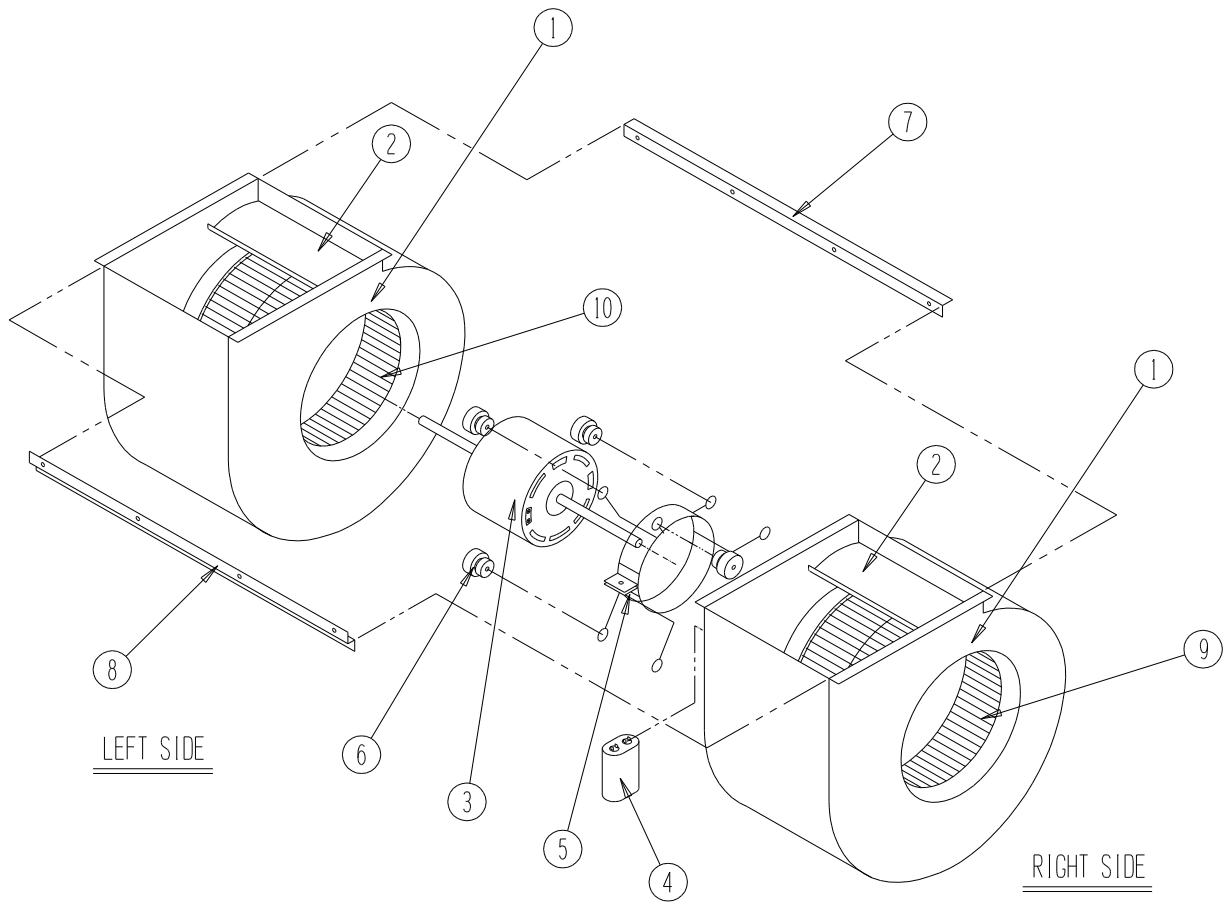

SEXP-346

Dwg. No.	Part Number	Description	S900-246	S900-247
1	151-111	Blower Housing	2	2
2	144-174	Diffuser	2	2
3	8103-025	Blower Motor (230/208)	X	
3	8103-026	Blower Mount (460)		X
4	8552-005	Capacitor	X	
4	8552-004	Capacitor		X
5	8200-031	Motor Mount	X	X
6	5451-011	Grommets	6	6
7	105-870	Back Brace	X	X
8	103-401	Front Brace	X	X
9	5152-090	Blower Wheel	X	X
10	5152-091	Blower Wheel	X	X