REPLACEMENT PARTS MANUAL

Q-Tec SERIES PACKAGED HEAT PUMP

Models:

QW2S1 QW3S1
QW4S1 QW5S1

General Notes

- Revised and/or additional pages may be issued from time to time.
- A complete and current manual consists of pages shown in the following contents section.

Contents

Description	Page
Cabinet Components	
◆ Exploded View	2
◆ Usage List	3
Functional Components	
◆ Exploded View	4
◆ Usage List	5
Control Panel Components	
◆ Exploded View	6
◆ Usage List	7
◆ Exploded View	8
◆ Usage List	9
Blower Assembly Components	
◆ Exploded View	10
◆ Usage List	11
Optional Climate Control Components	
◆ Exploded View	12
◆ Usage List	13
Wall Sleeve Cabinet Components	
◆ Exploded View	14
◆ Usage List	15



Bard Manufacturing Company, Inc.
Bryan, Ohio 43506
Since 1914...Moving ahead, just as planned.

Manual: 2110-580B
Supersedes: 2110-580A
File: Tab 14
Date: 05-06-11

CABINET COMPONENTS

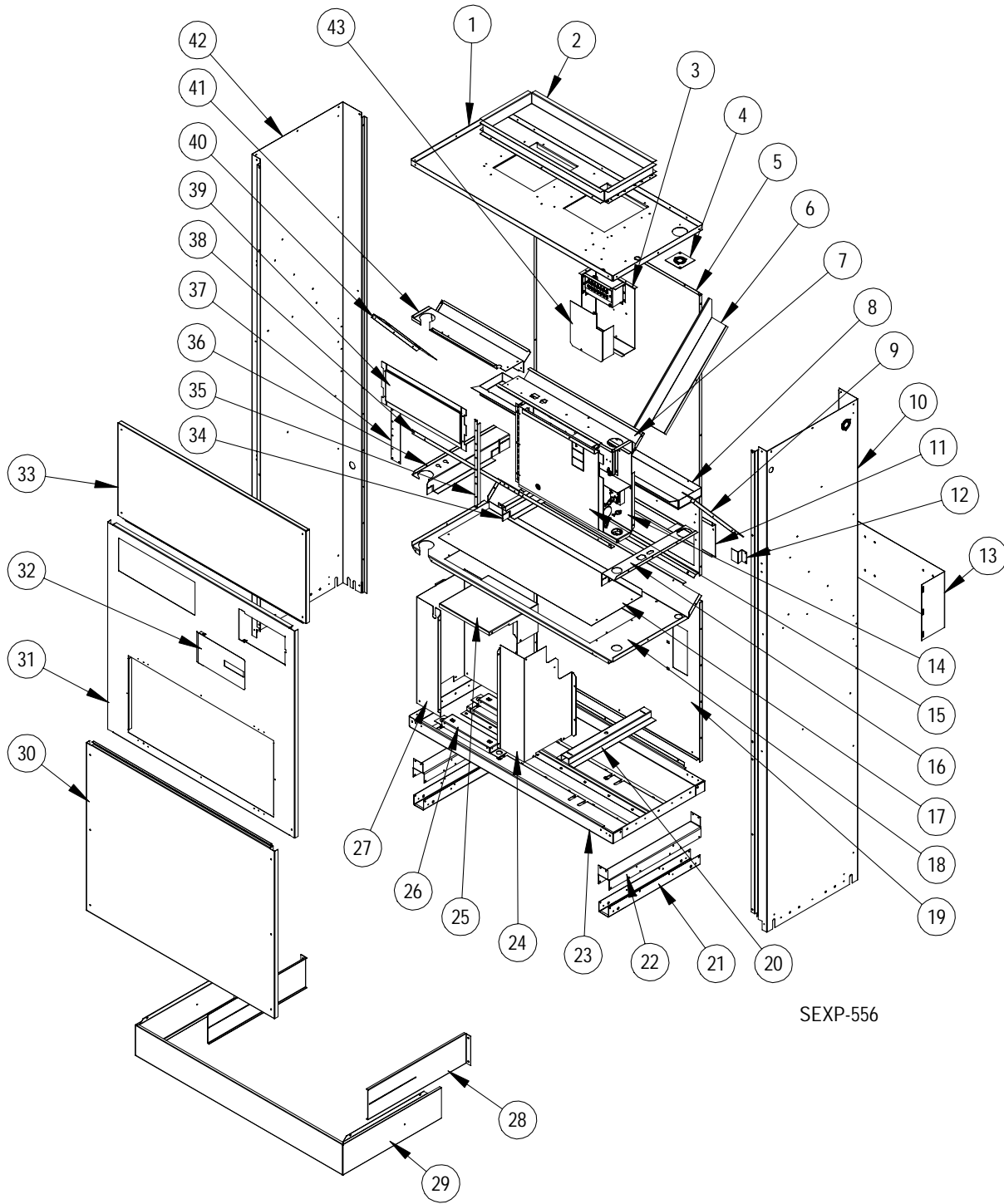

SEXP-556

This Exploded View is referenced in Table on Page 3

CABINET COMPONENTS

* Exterior cabinet parts are manufactured with various paint color options. To ensure that you receive the proper paint color, you must include the complete model and serial number of the unit for which cabinet parts are being ordered.

QW2S1-A, -B, -C
QW3S1-A, -B, -C
QW4S1-A, -B, -C
QW5S1-A, -B, -C

Drawing No.	Part No.	Description	QW2S1-A, -B, -C QW3S1-A, -B, -C	QW4S1-A, -B, -C QW5S1-A, -B, -C
1	S507-279	Top Assembly	X	
1	S507-278	Top Assembly		X
2	111-142	Outlet Duct Flange	2	
2	111-138	Outlet Duct Flange		2
3	117-285	Low Voltage Box Assembly	X	X
4	136-359	T.K.O. Plate	X	X
5	509-231	Back Assembly	X	
5	509-230	Back Assembly		X
6	134-154	Wire Channel	X	X
7	534-191	Evaporator Coil Shield - Right	X	
7	534-195	Evaporator Coil Shield - Right		X
8	523-104	Evaporator Drain Pan Assembly	X	
8	523-105	Evaporator Drain Pan Assembly		X
9	140X277	Right Evaporator Support	X	X
10	501-557-*	Ride Side Assembly	X	X
11	542-054	Fresh Air Blank-Off Plate Assembly	X	X
12	103-443	Door Latch Offset	X	X
13	113-289	Wall Mounting Bracket	2	2
14	See Pages 7 & 9	Control Panel Components	X	X
15	S132-165	Circuit Breaker Door Inner (230V Models)	X	X
15	S132-173	Disconnect Door (460V Models)	X	X
16	113-382	Right Filter Bracket	X	
16	113-383	Right Filter Bracket		X
17	537-584	Condenser Blank-Off Plate	X	X
18	521-442	Condenser Partition Assembly	X	
18	521-439	Condenser Partition Assembly		X
19	509-233	Lower Back with Cage Nuts	X	
19	509-223	Lower Back with Cage Nuts		X
20	140-026	Water Coil Hold Down (230V Models)	X	X
20	140-278	Water Coil Hold Down (460V Models)	X	X
21	140-276	Lower Roller Support	2	2
22	140-280	Upper Roller Support	2	2
23	S127-384-X	Lower Base Assembly	X	
23	S127-379-X	Lower Base Assembly		X
24	543-102	Compressor Enclosure Cover Assembly	X	X
25	543-100	Compressor Enclosure Top Assembly	X	X
26	S102-459	Compressor Rail	X	X
27	543-101	Compressor Enclosure Back Assembly	X	X
28	135-258-6	Base Trim Extension	2	2
29	535-253-6	Base Trim Assembly with Extension	X	
29	535-259-6	Base Trim Assembly with Extension		X
30	552-332-*	Condenser Door Assembly	X	
30	553-470-*	Condenser Door Assembly		X
31	553-468-*	Filter Door Assembly with Circuit Breaker Door	X	
31	553-469-*	Filter Door Assembly with Circuit Breaker Door		X
32	153-336-*	Circuit Breaker Door	X	X
33	S552-331-*	Blower Door Assembly	X	
33	S552-333-*	Blower Door Assembly		X
34	112X283	Center Right Filter Bracket	X	X
34	112Y283	Center Left Filter Bracket	X	X
35	104-1096	Right Thermostat Support Angle	X	X
36	113-305	Left Filter Bracket	X	X
37	104-1157	Left Thermostat Support Angle	X	X
38	104-1097	Front Filter Angle	X	
38	104-1101	Front Filter Angle		X
39	See Page 13	Thermostat Mounting Plate	X	X
40	140Y277	Left Evaporator Support	X	X
41	534-212	Left Evaporator Coil Shield	X	X
42	501-573-*	Left Side Assembly	X	X
43	133-201	Low Voltage Box Cover	X	X

This Table references Exploded View on Page 2

FUNCTIONAL COMPONENTS

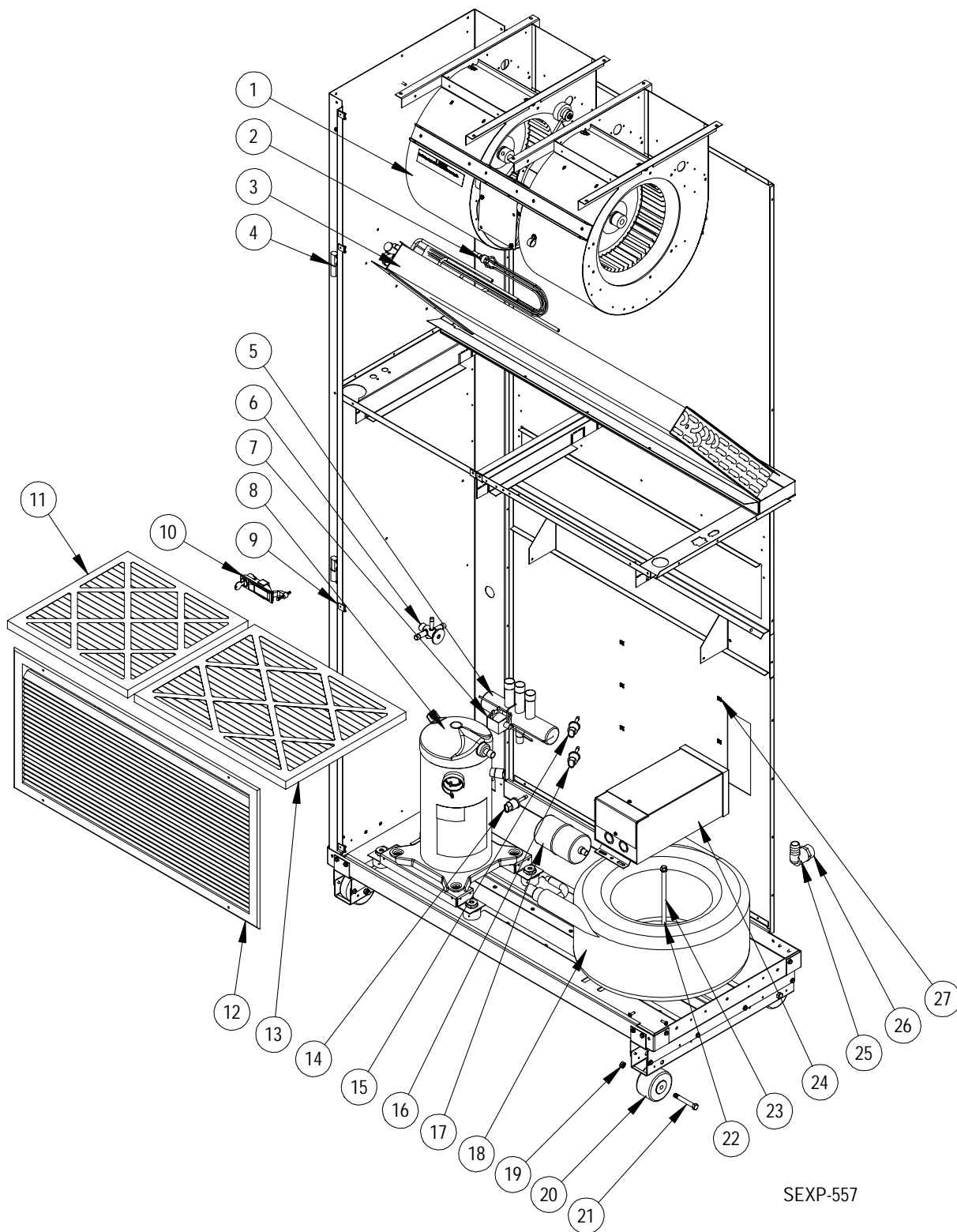

SEXP-557

This Exploded View is referenced in Table on page 5

FUNCTIONAL COMPONENTS

Drawing No.	Part No.	Description	QW2S1-A	QW2S1-B	QW2S1-C	QW3S1-A	QW3S1-B	QW3S1-C	QW4S1-A	QW4S1-B	QW4S1-C	QW5S1-A	QW5S1-B	QW5S1-C
1	S900-301-001	Blower Assembly	X	X	X									
1	S900-299-001	Blower Assembly				X	X	X						
1	S900-300-001	Blower Assembly							X	X	X			
1	S900-300-002	Blower Assembly										X	X	X
2	5625-007	Distributor Cooling	X	X	X	X	X	X						
2	5625-008	Distributor Cooling							X	X	X			
2	5625-010	Distributor Cooling										X	X	X
3	5060-118BX	Evaporator Coil	X	X	X	X	X	X						
3	5060-150BX	Evaporator Coil							X	X	X			
3	5060-119BX	Evaporator Coil										X	X	X
4	5400-005	Hinge	2	2	2	2	2	2	2	2	2	2	2	2
5	5650-038	Reversing Valve with 24V Solenoid Coil	X	X	X									
5	5650-039	Reversing Valve with 24V Solenoid Coil				X	X	X						
5	5650-040	Reversing Valve with 24V Solenoid Coil							X	X	X	X	X	X
6	5651-202	TXV	X	X	X	X	X	X						
6	5651-203	TXV							X	X	X			
6	5651-204	TXV										X	X	X
7	5650-042	Reversing Valve Solenoid, Red Casing (Ranco)	X	X	X	X	X	X	X	X	X	X	X	X
7	5650-043	Reversing Valve Solenoid, Black Casing (Wilspec)	X	X	X	X	X	X	X	X	X	X	X	X
7	5650-046	Reversing Valve Solenoid, Black Casing (San Hua)	X	X	X	X	X	X	X	X	X	X	X	X
8	8000-335	Compressor	X											
8	8000-353	Compressor		X										
8	8000-354	Compressor			X									
8	8000-269	Compressor				X								
8	8000-272	Compressor					X							
8	8000-275	Compressor						X						
8	8000-267	Compressor							X					
8	8000-270	Compressor								X				
8	8000-273	Compressor									X			
8	8000-268	Compressor										X		
8	8000-271	Compressor											X	
8	8000-274	Compressor												X
9	1012-315	"U" Clip Fastener	8	8	8	8	8	8	8	8	8	8	8	8
10	1171-049	Keylatch/Circuit Breaker Door	X	X	X	X	X	X	X	X	X	X	X	X
11	7004-034	Air Filter 2 Pleated (16 x 16 x 2)	X	X	X	X	X	X	X	X	X	X	X	X
12	7051-034	Return Air Grille (for Beige & Buckeye Gray Units)	X	X	X	X	X	X						
12	7051-061	Return Air Grille (for Vinyl Units)	X	X	X	X	X	X						
12	7051-039	Return Air Grille (for Beige & Buckeye Gray Units)							X	X	X	X	X	X
12	7051-063	Return Air Grille (for Vinyl Units)							X	X	X	X	X	X
13	7004-035	Air Filter 2 Pleated (16 x 20 x 2)	X	X	X	X	X	X						
13	7004-025	Air Filter 2 Pleated (16 x 25 x 2)							X	X	X	X	X	X
14	1804-0316	High Pressure Switch	X	X	X	X	X	X	X	X	X	X	X	X
15	1804-0404	Low Pressure Switch	X	X	X	X	X	X	X	X	X	X	X	X
16	1804-0405	Low Pressure Switch	X	X	X	X	X	X	X	X	X	X	X	X
17	5201-019	Filter / Drier	X	X	X	X	X	X						
17	5201-020	Filter / Drier							X	X	X	X	X	X
18	S917-0148	Water Coil Assembly	X	X	X	X	X	X						
18	S917-0149	Water Coil Assembly (Optional Cupronickel Coil)	X	X	X	X	X	X						
18	S917-0150	Water Coil Assembly							X	X	X			
18	S917-0151	Water Coil Assembly (Optional Cupronickel Coil)							X	X	X			
18	S917-0152	Water Coil Assembly										X	X	X
18	S917-0153	Water Coil Assembly (Optional Cupronickel Coil)										X	X	X
19	1012-224	Nut - Locking	4	4	4	4	4	4	4	4	4	4	4	4
20	1171-035	Wheel	4	4	4	4	4	4	4	4	4	4	4	4
21	1012-129	Bolt - Shoulder	4	4	4	4	4	4	4	4	4	4	4	4
22	1012-226	Cage Nut	X	X	X	X	X	X	X	X	X	X	X	X
23	1012-167	3/8 x 7-1/2 Hex Head Bolt	X	X	X	X	X	X						
23	1012-168	3/8 x 9 Hex Head Bolt							X	X	X			
23	1012-169	3/8 x 10 Hex Head Bolt										X	X	X
24	8407-058	Stepdown Transformer 1.0 KVA	X	X	X	X	X	X	X	X	X			
24	8407-003	Stepdown Transformer 1.5 KVA (Units w/ERV)	X	X	X	X	X	X						
24	8407-004	Stepdown Transformer 2.0 KVA (Units w/ERV)							X	X	X	X	X	X
24	8407-003	Stepdown Transformer 1.5 KVA										X	X	X
25	6094-007	Barbed Drain Fitting	X	X	X	X	X	X	X	X	X	X	X	X
26	6093-011	3/4 Male Adapter	X	X	X	X	X	X	X	X	X	X	X	X
27	1012-218	1/4 Cage Nut	6	6	6	6	6	6	6	6	6	6	6	6
NS	4113-100	Wiring Diagram	X			X			X			X		
NS	4113-200	Wiring Diagram		X			X			X			X	
NS	4113-300	Wiring Diagram			X			X			X			X

CONTROL PANEL COMPONENTS

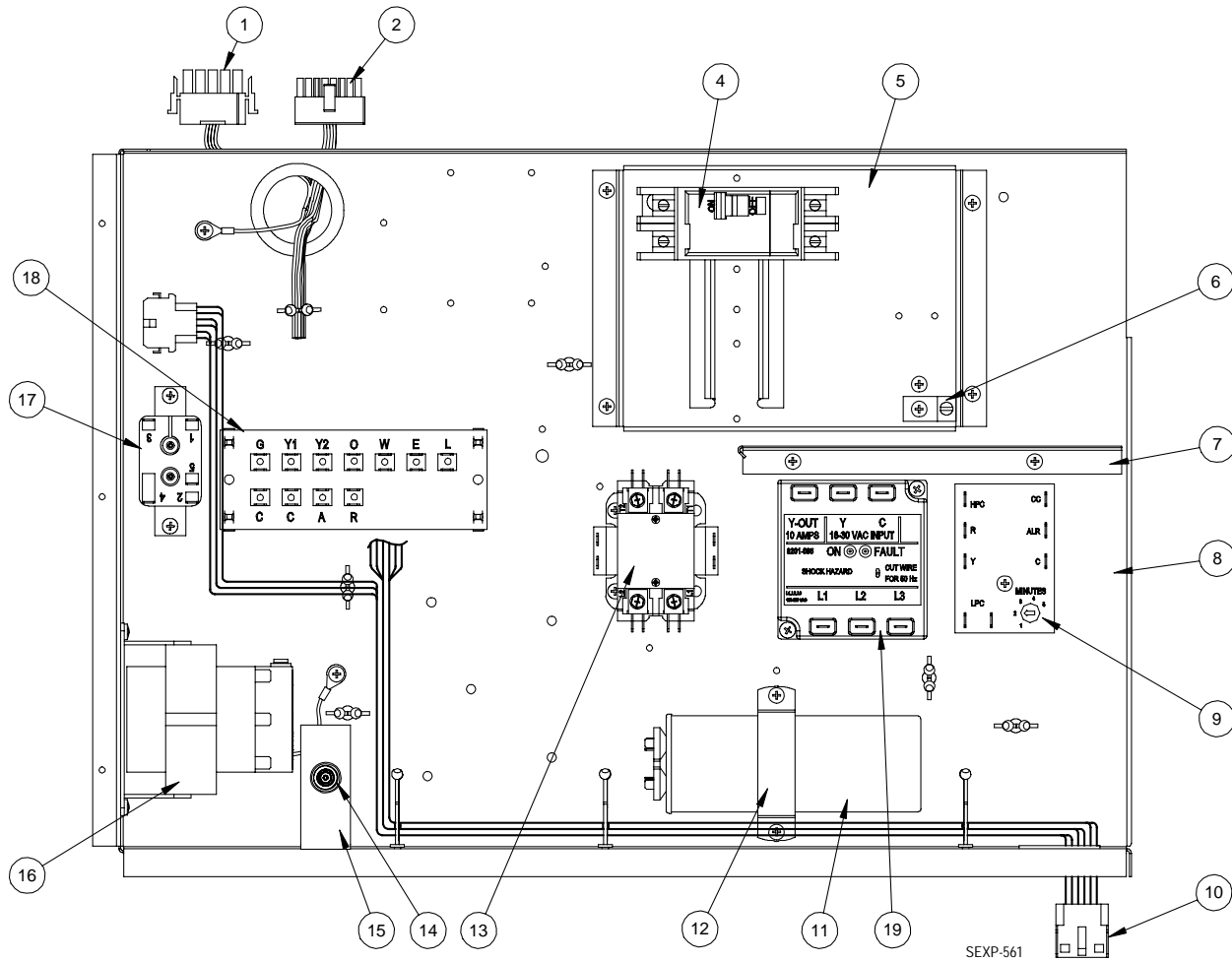

This Exploded View is referenced in Table on page 7

CONTROL PANEL COMPONENTS

Drawing No.	Part No.	Description	QW2S1-A	QW2S1-B	QW3S1-A	QW3S1-B	QW4S1-A	QW4S1-B	QW5S1-A	QW5S1-B
1	3000-1331	Wire Assembly	X	X	X	X	X	X	X	X
2	3000-1327	Wire Assembly	X	X	X	X	X	X	X	X
4	8615-037	Circuit Breaker 2 Pole 30A	X							
4	8615-054	Circuit Breaker 3 Pole 20A		X						
4	8615-055	Circuit Breaker 2 Pole 40A			X					
4	8615-052	Circuit Breaker 3 Pole 30A				X				
4	8615-040	Circuit Breaker 2 Pole 50A					X			
4	8615-043	Circuit Breaker 3 Pole 40A						X		
4	8615-041	Circuit Breaker 2 Pole 60A							X	
4	8615-044	Circuit Breaker 3 Pole 45A								X
5	126-267	Circuit Breaker Base	X	X	X	X	X	X	X	X
6	8611-006	Terminal	X	X	X	X	X	X	X	X
7	117-242	Circuit Breaker Box Partition	X	X	X	X	X	X	X	X
8	117-287	Control Panel	X	X	X	X	X	X	X	X
9	8201-088	Compressor Control Module	X	X	X	X	X	X	X	X
10	3000-1325	Wire Assembly	X	X	X	X	X	X	X	X
11	8552-086	Capacitor 35 - 370V	X							
11	8552-035	Capacitor 40 - 370V			X					
11	8552-087	Capacitor 45 - 370V					X			
11	8552-088	Capacitor 80 - 370V							X	
12	8550-006	Capacitor Bracket	X							
12	8550-007	Capacitor Bracket			X		X			
12	8550-008	Capacitor Bracket							X	
13	8401-025	Contactora	X		X		X		X	
13	8401-002	Contactora		X		X		X		X
14	8611-094	Indicator Light	X	X	X	X	X	X	X	X
15	113-384	Light Bracket	X	X	X	X	X	X	X	X
16	8407-048	Transformer	X	X	X	X	X	X	X	X
17	8201-062	Relay	X	X	X	X	X	X	X	X
18	8607-029	Terminal Strip	X	X	X	X	X	X	X	X
19	8201-085	3 Phase Line Monitor		X		X		X		X

This Table references Exploded View on Page 6

CONTROL PANEL COMPONENTS

Drawing No.	Part No.	Description	QW2S1-C	QW3S1-C	QW4S1-C	QW5S1-C
1	3000-1331	Wire Assembly	X	X	X	X
2	3000-1327	Wire Assembly	X	X	X	X
3	8607-017	Terminal Block	X	X	X	X
4	S8615-068	460V Rotary Disconnect	X	X	X	X
5	126-323	Rotary Disconnect Base	X	X	X	X
6	8611-006	Terminal	X	X	X	X
7	117-242	Circuit Breaker Box Partition	X	X	X	X
8	117-287	Control Panel	X	X	X	X
9	8201-088	Compressor Control Module	X	X	X	X
10	3000-1325	Wire Assembly	X	X	X	X
11	8201-085	3 Phase Line Monitor	X	X	X	X
12	8614-041	Fuse Block	X	X	X	X
13	8401-002	Contact	X	X	X	X
14	8611-094	Indicator Light	X	X	X	X
15	113-384	Light Bracket	X	X	X	X
16	8407-050	Transformer	X	X	X	X
17	8201-062	Relay	X	X	X	X
18	8607-029	Terminal Strip	X	X	X	X
19	8614-047	Fuse 3.2A	2	2	2	
19	8614-046	Fuse 5A (Units with ERV)	2	2		
19	8614-042	Fuse 7A (Units with ERV)			2	2
19	8614-046	Fuse 5A				2

This Table references Exploded View on Page 8

BLOWER ASSEMBLY COMPONENTS

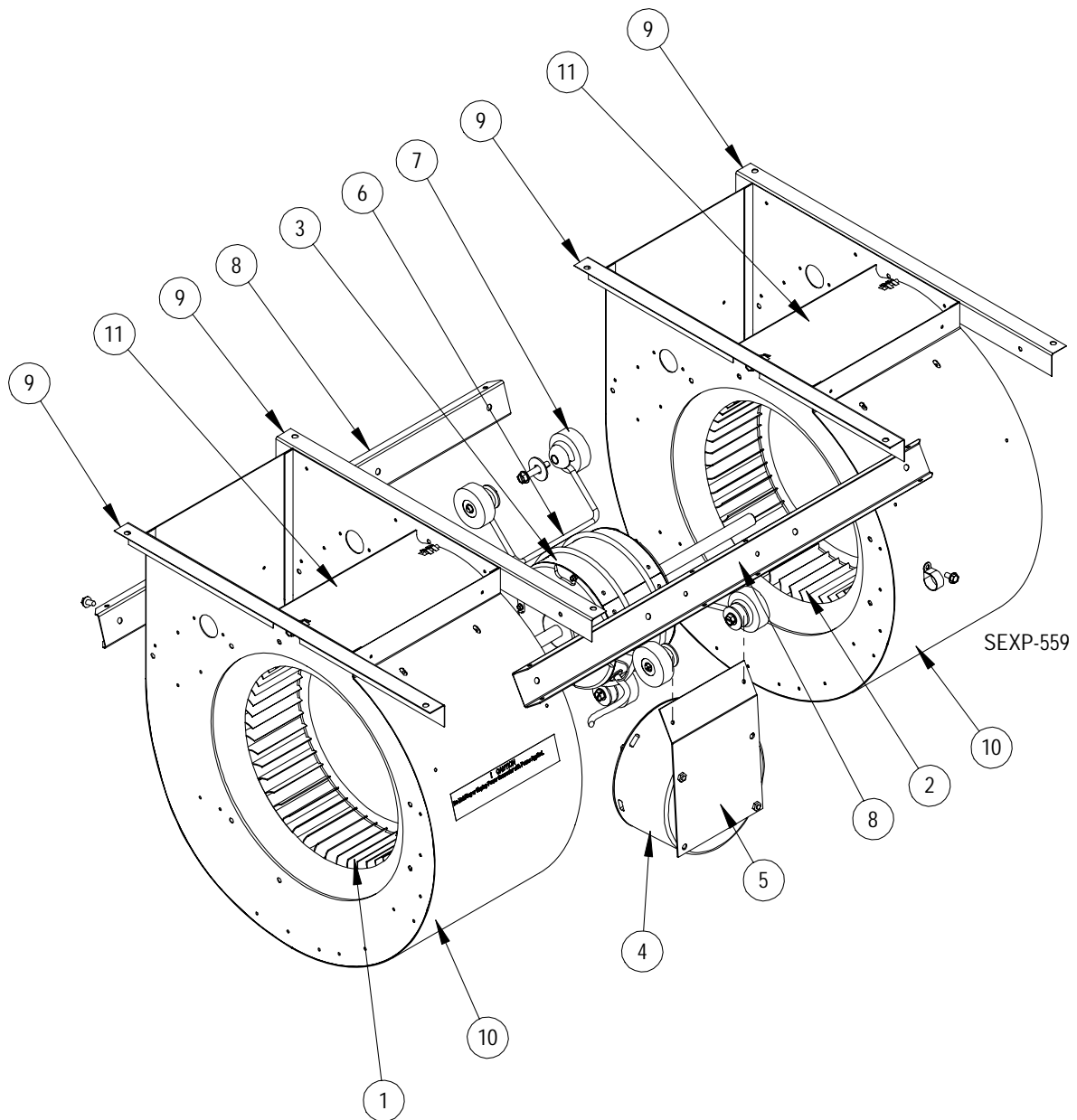

BLOWER ASSEMBLY COMPONENTS

			900-301-001	900-299-001	900-300-001	900-300-002
1	5152-096	Blower Wheel	X	X		
1	5152-011	Blower Wheel			X	X
2	5152-072	Blower Wheel	X	X		
2	5152-012	Blower Wheel			X	X
3	S8105-057-0066	1/3 HP Programmed Motor	X			
3	S8106-041-0067	1/2 HP Programmed Motor		X		
3	S8107-011-0068A	3/4 HP Programmed Motor			X	
3	S8107-011-0069A	3/4 HP Programmed Motor				X
4	C8105-057-0066	Programmed Motor Control Only	X			
4	C8106-041-0067	Programmed Motor Control Only		X		
4	C8107-011-0068A	Programmed Motor Control Only			X	
4	C8107-011-0069A	Programmed Motor Control Only				X
5	113-380	Blower Motor Control Bracket	X	X	X	X
6	8200-040	Dual Motor Mount	X	X	X	X
7	5451-011	Grommet	6	6	6	6
8	165-572	Blower Support Channel	2	2	2	2
9	104-980	Blower Angle	4	4	4	4
10	151-117	Blower Housing	2	2		
10	151-101	Blower Housing			2	2
11	144-167	Diffuser	2	2		
11	144-166	Diffuser			2	2

OPTIONAL CLIMATE CONTROLS

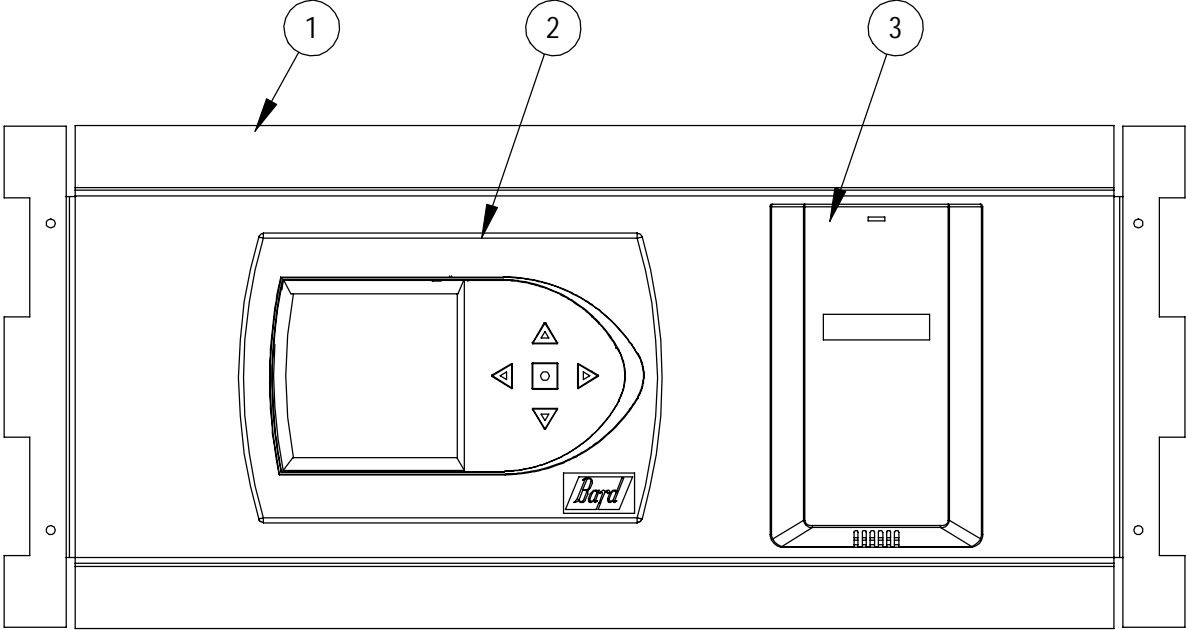

SEXP-560

OPTIONAL CLIMATE CONTROLS

Drawing No.	Part No.	Description	ALL UNITS			
			Option X	Option D	Option H	Option K
1	S127-313-*	Thermostat Plate	X			
1	S127-308-*	Thermostat Plate		X		
1	S127-372-*	Thermostat Plate			X	
1	S127-409-*	CO ₂ Plate				X
2	8403-060	Electronic / Programmable Manual / Auto Changeover		X	X	
3	8403-056	CO ₂ Sensor with Relay			X	X
NS	4115-100	Wiring Diagram		X		
NS	4115-101	Wiring Diagram			X	
NS	4115-102	Wiring Diagram	X			
NS	4115-105	Wiring Diagram				X
NS	8607-021	Terminal Strip 8 Terminal	X			
NS	8607-029	Terminal Strip	X			X
NS	3000-1332	Wire Assembly Thermostat Connection	X			X
NS	3000-1333	Wire Assembly CO ₂ Control Connection	X			
NS	3000-1334	Wire Assembly Thermostat Connection		X	X	
NS	3000-1335	Wire Assembly CO ₂ Control Connection			X	X

* Exterior cabinet parts are manufactured with various paint color options. To ensure that you receive the proper paint color, you must include the complete model and serial number of the unit for which cabinet parts are being ordered.

CLIMATE CONTROL OPTION NOMENCLATURE AS SHOWN IN UNIT MODEL NUMBER

QW 3S1 - A 02 X X X X X X

- X – None
- D – Electronic, programmable, manual changeover
- H – Electronic, programmable, manual/auto changeover, CO₂ Control
- K – CO₂ Control with remote thermostat connection

WALL SLEEVE CABINET COMPONENTS

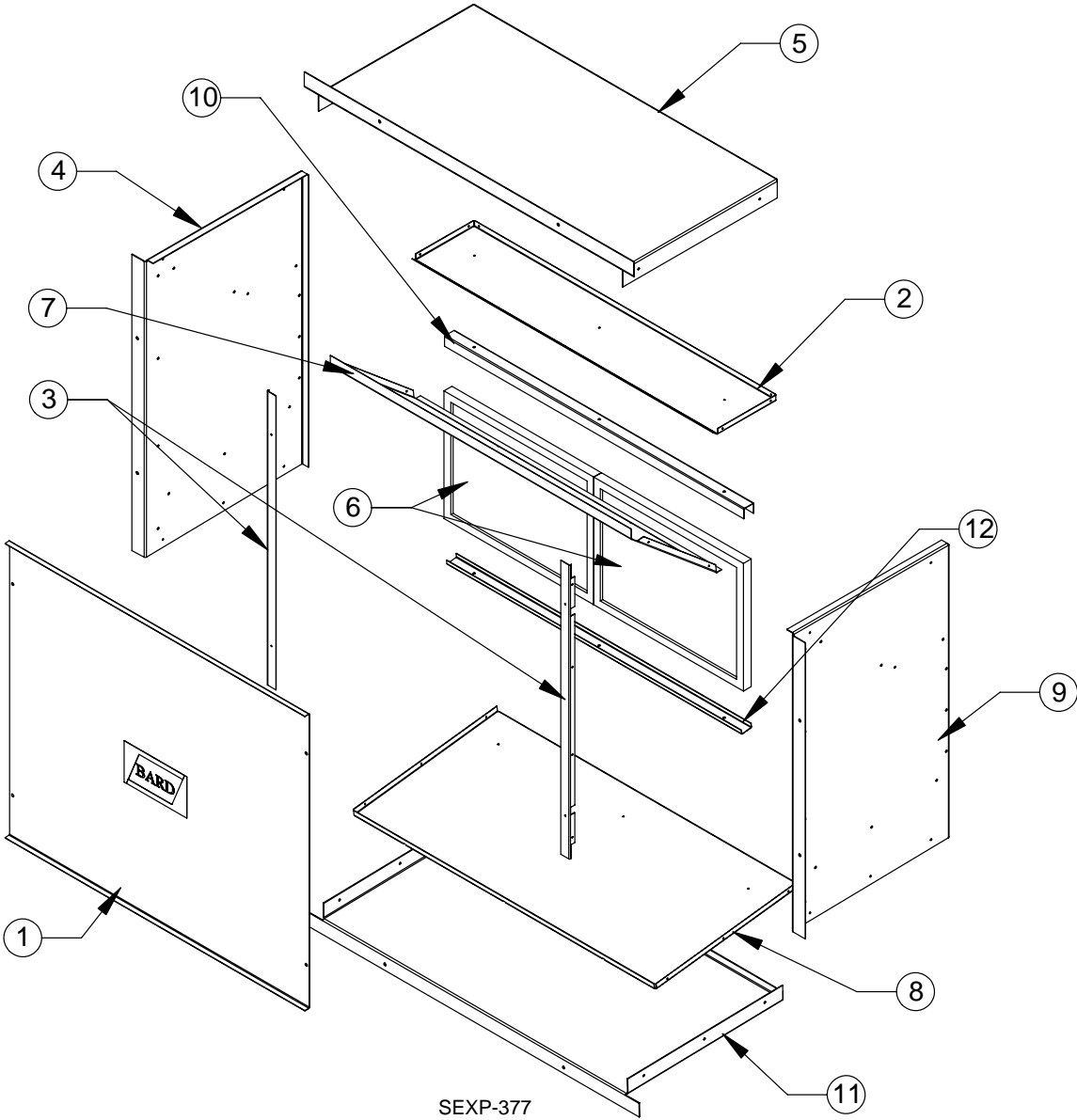

WALL SLEEVE CABINET COMPONENTS

Drawing No.	Part No.	Description	QWVS42
1	142-076	Cover	X
2	121-350-X	Top Partition	X
3	105-1103-X	Angle	2
4	110-073-X	Left Side	X
5	110-074-X	Top	X
6	7003-056	Mist Eliminator	2
7	111-076-X	Air Deflector	X
8	121-349-X	Partition	X
9	110-072-X	Right Side	X
10	165-566-X	Upper Support Channel	X
11	110-075-X	Base	X
12	165-567-X	Lower Support Channel	X