

---

# REPLACEMENT PARTS MANUAL

---

## WALL MOUNTED PACKAGED HEAT PUMP

Models:

T36H1-A T36H1DA T42H1-A T42H1DA T48H1-A T48H1DA T60H1-A T60H1DA  
T36H1-B T36H1DB T42H1-B T42H1DB T48H1-B T48H1DB T60H1-B T60H1DB  
T36H1-C T36H1DC T42H1-C T42H1DC T48H1-C T48H1DC T60H1-C T60H1DC

---

### General Notes

- Revised and/or additional pages may be issued from time to time.
- A complete and current manual consists of pages shown in the following contents section.

### Important

- Contact the installing and/or local Bard distributor for all parts requirements. Be sure to have the complete model and serial number available from the unit rating plates.

### Contents

<u>Description</u>	<u>Page</u>
Cabinet Components	
♦ Exploded View.....	2
♦ Usage List .....	3
♦ Usage List .....	4
Functional Components	
♦ Exploded View.....	5
♦ Usage List .....	6
♦ Usage List .....	7
♦ Usage List .....	8
♦ Usage List .....	9
Control Panel	
♦ Layout View .....	10
♦ Usage List .....	11
♦ Usage List .....	12
Blower Assembly	
♦ Exploded View.....	13
♦ Usage List .....	13



*Climate Control Solutions*

Bard Manufacturing Company, Inc.  
Bryan, Ohio 43506  
www.bardhvac.com

Manual: 2110-584N  
Supersedes: 2110-584M  
Date: 6-17-19

# CABINET COMPONENTS

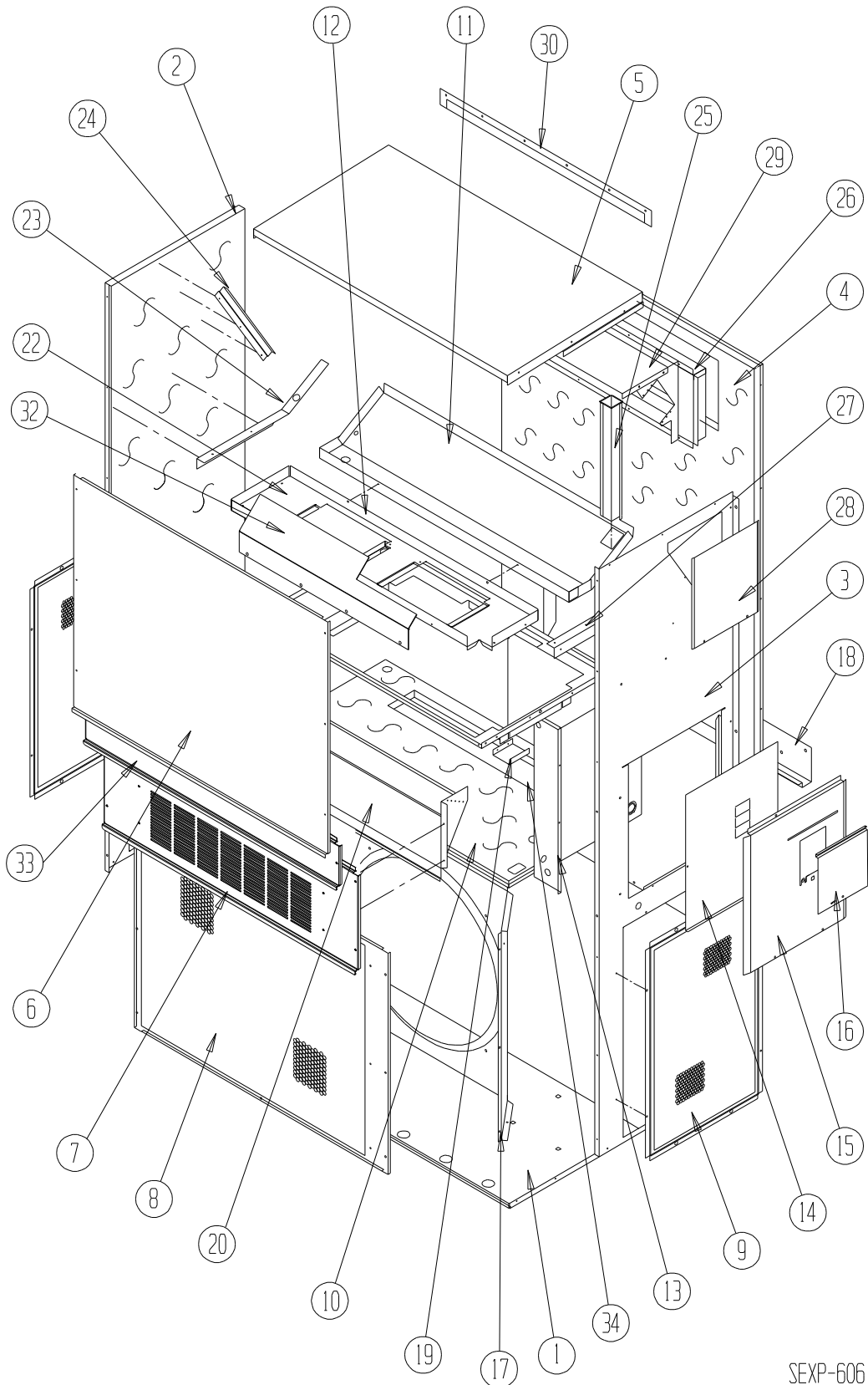

SEXP-606

# CABINET COMPONENTS

Dwg. No.	Part Number	Description	T36H1-A, -B, DA, DB	T36H1-C, DC	T42H1-A, -B, DA, DB	T42H1-C, DC
1	S127X214	Lower Base	X	X	X	X
1	S127X369 ③	Lower Base	X	X	X	X
2	S500-262-* ①	Left Side	X	X	X	X
2	S500-464 ②	Left Side	X	X	X	X
2	S500X518 ③	Left Side	X	X	X	X
3	S500-261-* ①	Right Side	X	X	X	X
3	S500-463 ②	Right Side	X	X	X	X
3	S500-517 ③	Right Side	X	X	X	X
4	S508-098	Back	X	X	X	X
4	S508-191 ②	Back	X	X	X	X
4	S508-221 ③	Back	X	X	X	X
5	S506-142-* ①	Top	X	X	X	X
5	S506-251 ②	Top	X	X	X	X
5	S506-274 ③	Top	X	X	X	X
6	S515-144-* ①	Upper Front	X	X	X	X
6	S514-142 ②	Upper Front	X	X	X	X
6	S514-162 ③	Upper Front	X	X	X	X
7	S553-383-* ①	Vent Option Door	X	X	X	X
7	S553-408-* ①	Vent Option Door with ERV	X	X	X	X
7	S552-456 ②	Vent Option Door	X	X	X	X
7	S553-449 ③	Vent Option Door	X	X	X	X
8	118-048-* ①	Condenser Grille	X	X	X	X
8	118-064 ②	Condenser Grille	X	X	X	X
8	118-072 ③	Condenser Grille	X	X	X	X
9	118-057-* ①	Side Grille	2	2	2	2
9	118-063 ②	Side Grille	2	2	2	2
9	118-073 ③	Side Grille	2	2	2	2
10	S521X258	Condenser Partition	X	X	X	X
11	S123-122	Drain Pan	X	X	X	X
12	121X216	Blower Partition	X	X	X	X
13	Control Panel Assembly	See Control Panel Assembly Drawing and Parts List Assembly	X	X	X	X
14	S132-114	Control Panel Cover (Inner)	X		X	
14	S132-183	Control Panel Cover (Inner)		X		X
15	S533-113-* ①	Control Panel Cover (Outer)	X	X	X	X
15	S533-185 ②	Control Panel Cover (Outer)	X	X	X	X
15	S533-195 ③	Control Panel Cover (Outer)	X	X	X	X
16	S153-218-* ①	Disconnect Access Door	X	X	X	X
16	S153-387 ②	Disconnect Access Door	X	X	X	X
16	S153-405 ③	Disconnect Access Door	X	X	X	X
17	125-024	Fan Shroud	X	X	X	X
17	125-058 ③	Fan Shroud	X	X	X	X
18	113-140	Bottom Mounting Bracket	X	X	X	X
19	137-209	Fill	X	X	X	X
20	BFAD-5	Fresh Air Damper Assembly	X	X	X	X
22	131X099	Filter Tray	X	X	X	X
23	105X877	Left Side Support	X	X	X	X
24	147-046	Left Evaporator Support	X	X	X	X
25	135-128	Raceway	2	2	2	2
26	S111X034	Outlet Air Frame Assembly	X	X	X	X
27	105X878	Right Side Support	X	X	X	X
28	S143-042-* ①	Right Side Cover Plate (Outer)	X	X	X	X
28	S143-105 ②	Right Side Cover Plate (Outer)	X	X	X	X
28	S143-125 ③	Right Side Cover Plate (Outer)	X	X	X	X
29	135-129	Heat Shield	X	X	X	X
30	113-150-* ①	Top Rain Flashing	X	X	X	X
30	113-359-* ③	Top Rain Flashing	X	X	X	X
32	135-175	Air Baffle	X	X	X	X
33	S553-384-* ①	Filter Door Assembly	X	X	X	X
33	S552-457 ②	Filter Door Assembly	X	X	X	X
33	S553-450 ③	Filter Door Assembly	X	X	X	X
34	S536-258	Condenser Part. Blank-Off Plate	X	X	X	X
NS	141-356	Compressor Mounting Plate	X	X	X	X

① Exterior cabinet parts are manufactured with various paint color options. To ensure the proper paint color is received, please reference the following codes:

Beige	-X	White	-1	Buckeye Gray	-4
Desert Brown	-5	Dark Bronze	-8		
② Aluminum	A	③ Stainless Steel	S		

# CABINET COMPONENTS

Dwg. No.	Part Number	Description	T48H1-A, -B, DA, DB	T48H1-C, DC	T60H1-A, -B, DA, DB	T60H1-C, DC
1	S127X214	Lower Base	X	X	X	X
1	S127X369 ③	Lower Base	X	X	X	X
2	S500-613-* ①	Left Side	X	X	X	X
2	S500-615 ②	Left Side	X	X	X	X
2	S500-617 ③	Left Side	X	X	X	X
3	S500-612-* ①	Right Side	X	X	X	X
3	S500-614 ②	Right Side	X	X	X	X
3	S500-616 ③	Right Side	X	X	X	X
4	S508-251	Back	X	X	X	X
4	S508-252 ②	Back	X	X	X	X
4	S508-253 ③	Back	X	X	X	X
5	S506-142-* ①	Top	X	X	X	X
5	S506-251 ②	Top	X	X	X	X
5	S506-274 ③	Top	X	X	X	X
6	S515-193-* ①	Upper Front	X	X	X	X
6	S514-194 ②	Upper Front	X	X	X	X
6	S514-195 ③	Upper Front	X	X	X	X
7	S553-383-* ①	Vent Option Door	X	X	X	X
7	S553-408-* ①	Vent Option Door with ERV	X	X	X	X
7	S552-456 ②	Vent Option Door	X	X	X	X
7	S553-449 ③	Vent Option Door	X	X	X	X
8	118-085-* ①	Condenser Grille	X	X	X	X
8	118-087 ②	Condenser Grille	X	X	X	X
8	118-089 ③	Condenser Grille	X	X	X	X
9	118-086-* ①	Side Grille	2	2	2	2
9	118-088 ②	Side Grille	2	2	2	2
9	118-090 ③	Side Grille	2	2	2	2
10	S521X258	Condenser Partition	X	X	X	X
11	S123-122	Drain Pan	X	X	X	X
12	121X216	Blower Partition	X	X	X	X
13	Control Panel Assembly	See Control Panel Assembly Drawing and Parts List Assembly	X	X	X	X
14	S132-114	Control Panel Cover (Inner)	X		X	
14	S132-183	Control Panel Cover (Inner)		X		X
15	S533-113-* ①	Control Panel Cover (Outer)	X	X	X	X
15	S533-185 ②	Control Panel Cover (Outer)	X	X	X	X
15	S533-195 ③	Control Panel Cover (Outer)	X	X	X	X
16	S153-218-* ①	Disconnect Access Door	X	X	X	X
16	S153-387 ②	Disconnect Access Door	X	X	X	X
16	S153-405 ③	Disconnect Access Door	X	X	X	X
17	125-063	Fan Shroud	X	X	X	X
17	125-064 ③	Fan Shroud	X	X	X	X
18	113-140	Bottom Mounting Bracket	X	X	X	X
19	137-209	Fill	X	X	X	X
20	BFAD-5	Fresh Air Damper Assembly	X	X	X	X
22	131X099	Filter Tray	X	X	X	X
23	105X877	Left Side Support	X	X	X	X
24	147-046	Left Evaporator Support	X	X	X	X
25	135-303	Raceway	2	2	2	2
26	S111X034	Outlet Air Frame Assembly	X	X	X	X
27	105X878	Right Side Support	X	X	X	X
28	S143-144-* ①	Right Side Cover Plate (Outer)	X	X	X	X
28	S143-145 ②	Right Side Cover Plate (Outer)	X	X	X	X
28	S143-146 ③	Right Side Cover Plate (Outer)	X	X	X	X
29	135-129	Heat Shield	X	X	X	X
30	113-150-* ①	Top Rain Flashing	X	X	X	X
30	113-359-* ③	Top Rain Flashing	X	X	X	X
33	S553-384-* ①	Filter Door Assembly	X	X	X	X
33	S552-457 ②	Filter Door Assembly	X	X	X	X
33	S553-450 ③	Filter Door Assembly	X	X	X	X
34	S536-258	Condenser Part. Blank-Off Plate	X	X	X	X
NS	141-356	Compressor Mounting Plate	X	X	X	X

① Exterior cabinet parts are manufactured with various paint color options. To ensure the proper paint color is received, please reference the following codes:

Beige	-X	White	-1	Buckeye Gray	-4
Desert Brown	-5	Dark Bronze	-8		
② Aluminum	A	③ Stainless Steel	S		

# FUNCTIONAL COMPONENTS

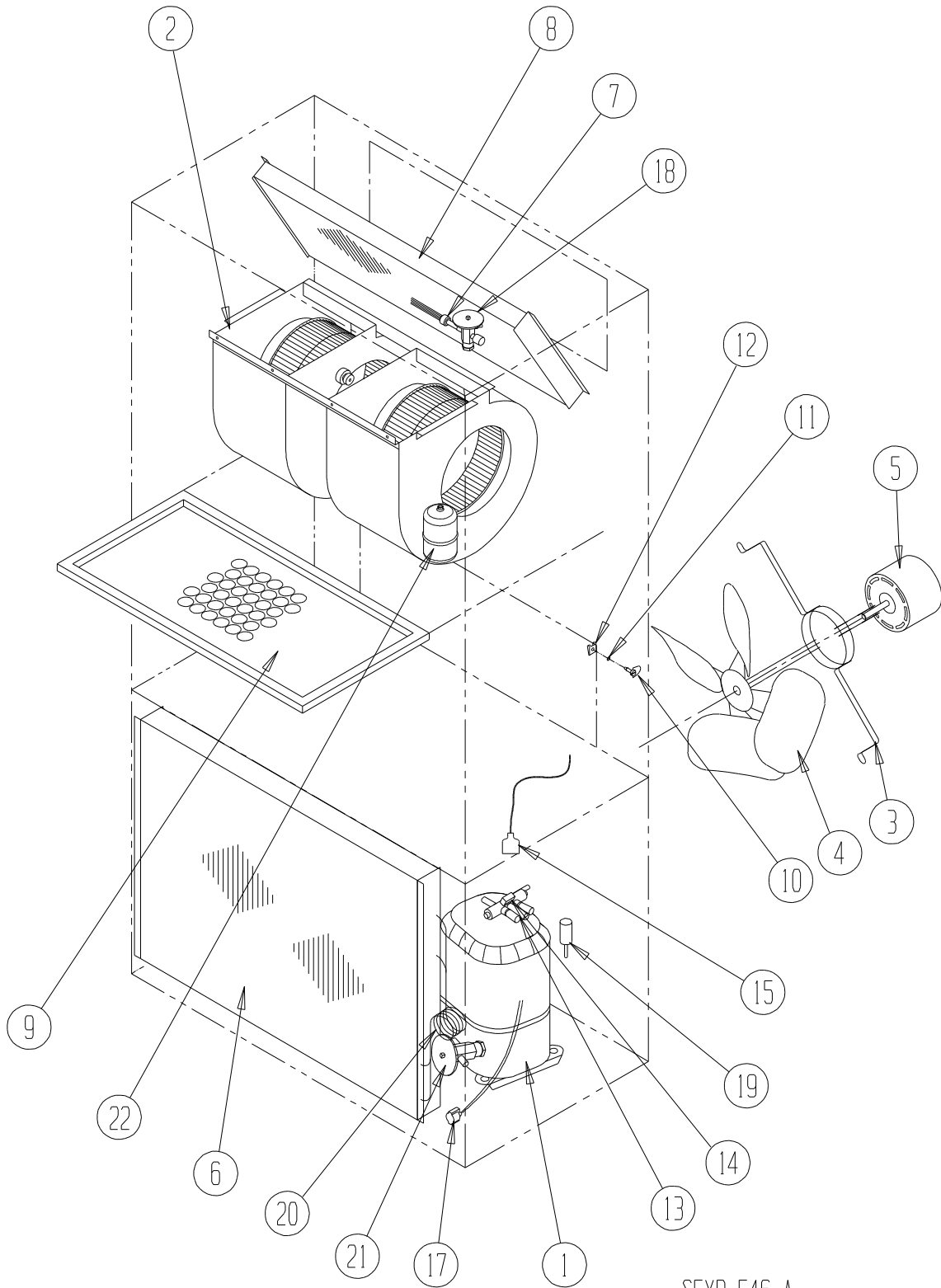

SEXP-546 A

# FUNCTIONAL COMPONENTS

Dwg. No.	Part Number	Description	T36H1-A	T36H1-B	T36H1-C	T42H1-A	T42H1-B	T42H1-C
1	8000-278	Compressor	X					
1	8000-283	Compressor		X				
1	8000-342	Compressor			X			
1	8000-362	Compressor				X		
1	8000-363	Compressor					X	
1	8000-364	Compressor						X
2	S900-272-003	Blower Assembly	X	X	X			
2	S900-273-008	Blower Assembly				X	X	X
3	8200-004	Fan Motor Mount	X	X	X	X	X	X
4	5151-027	Fan Blade	X	X	X	X	X	X
5	8105-068	Condenser Motor	X	X		X	X	
5	8105-071	Condenser Motor			X			X
6	5051-107BX	Condenser Coil	X	X	X			
6	5051-167BX	Condenser Coil				X	X	X
7	800-0409	Cooling Distributor	X	X	X			
7	800-0383	Cooling Distributor				X	X	X
8	5060-164BX	Evaporator Coil	X	X	X	X	X	X
9	7004-016	Air Filter 1" Throw-Away	X	X	X	X	X	X
9	7004-064	Air Filter 2" Pleated MERV 13 ①	X	X	X	X	X	X
9	7004-049	Air Filter 2" Pleated MERV 11 ①	X	X	X	X	X	X
9	7004-031	Air Filter 2" Pleated MERV 8 ①	X	X	X	X	X	X
9	7004-027	Air Filter 2" Pleated MERV 6 ①	X	X	X	X	X	X
10	1171-022	1/4" Turn Fastener	X	X	X	X	X	X
11	1171-024	1/4" Turn Retainer	X	X	X	X	X	X
12	1171-023	1/4" Receptacle	X	X	X	X	X	X
13	5650-039	Reversing Valve with 24V Solenoid Coil	X	X	X			
13	5650-040	Reversing Valve with 24V Solenoid Coil				X	X	X
14	5650-042	Rev. Valve Solenoid, Red Casing (Ranco)	X	X	X	X	X	X
14	5650-043	Rev. Valve Solenoid, Black Casing (Wilspec)	X	X	X	X	X	X
14	5650-046	Rev. Valve Solenoid, Black Casing (San Hua)	X	X	X	X	X	X
15	5650-037	Molded Plug 36" Lead	X	X	X	X	X	X
17	8620-224	Defrost Sensor	X	X	X	X	X	X
19	1804-0462	High Pressure Switch (Flare) ①	X	X	X	X	X	X
20	800-0404	Heating Distributor Assembly	X	X	X			
20	800-0399	Heating Distributor Assembly				X	X	X
21	5651-216	Expansion Valve Heating	X	X	X	X	X	X
22	5201-010	Filter Drier	X	X	X	X	X	X
NS	1804-0107	Low Pressure Switch (Flare) ①	X	X	X	X	X	X
NS	CMH-20	Low Ambient Control (Flare) ①	X	X		X	X	
NS	CMH-21	Low Ambient Control (Flare) ①			X			X
NS	3000-1224	Molded Compressor Plug	X			X		
NS	3000-1231	Molded Compressor Plug		X	X		X	X
NS	8408-039	Discharge Line Thermosat	X	X	X	X	X	X

NS – Not Shown

① – Optional

# FUNCTIONAL COMPONENTS

Dwg. No.	Part Number	Description	T36H1DA	T36H1DB	T36H1DC	T42H1DA	T42H1DB	T42H1DC
1	8000-278	Compressor	X					
1	8000-283	Compressor		X				
1	8000-342	Compressor			X			
1	8000-362	Compressor				X		
1	8000-363	Compressor					X	
1	8000-364	Compressor						X
2	S900-272-003	Blower Assembly	X	X	X			
2	S900-273-008	Blower Assembly				X	X	X
3	8200-004	Fan Motor Mount	X	X	X	X	X	X
4	5151-027	Fan Blade	X	X	X	X	X	X
5	8105-068	Condenser Motor	X	X		X	X	
5	8105-071	Condenser Motor			X			X
6	5051-107BX	Condenser Coil	X	X	X			
6	5051-167BX	Condenser Coil				X	X	X
7	800-0342	Cooling Distributor	X	X	X			
7	800-0287	Cooling Distributor				X	X	X
8	917-0186BX	Evaporator Coil	X	X	X	X	X	X
9	7004-016	Air Filter 1" Throw-Away	X	X	X	X	X	X
9	7004-049	Air Filter 2" Pleated MERV 11 ①	X	X	X	X	X	X
9	7004-031	Air Filter 2" Pleated MERV 8 ①	X	X	X	X	X	X
9	7004-027	Air Filter 2" Pleated MERV 6 ①	X	X	X	X	X	X
10	1171-022	1/4" Turn Fastener	X	X	X	X	X	X
11	1171-024	1/4" Turn Retainer	X	X	X	X	X	X
12	1171-023	1/4" Receptacle	X	X	X	X	X	X
13	5650-039	Reversing Valve with 24V Solenoid Coil	X	X	X			
13	5650-040	Reversing Valve with 24V Solenoid Coil				X	X	X
14	5650-042	Rev. Valve Solenoid, Red Casing (Ranco)	X	X	X	X	X	X
14	5650-043	Rev. Valve Solenoid, Black Casing (Wilspec)	X	X	X	X	X	X
14	5650-046	Rev. Valve Solenoid, Black Casing (San Hua)	X	X	X	X	X	X
15	5650-037	Molded Plug 36" Lead	X	X	X	X	X	X
17	8620-224	Defrost Sensor	X	X	X	X	X	X
18	5651-210	Expansion Valve Cooling	X	X	X			
18	5651-178	Expansion Valve Cooling				X	X	X
19	1804-0462	High Pressure Switch (Flare) ①	X	X	X	X	X	X
20	800-0404	Heating Distributor Assembly	X	X	X			
20	800-0399	Heating Distributor Assembly				X	X	X
21	5651-216	Expansion Valve Heating	X	X	X	X	X	X
22	5201-010	Filter Drier	X	X	X	X	X	X
NS	800-0410	Orifice Assembly	X	X	X	X	X	X
NS	5650-045	3-Way Valve	X	X	X	X	X	X
NS	5651-146	Check Valve	X	X	X	X	X	X
NS	1804-0107	Low Pressure Switch (Flare) ①	X	X	X	X	X	X
NS	CMH-20	Low Ambient Control (Flare) ①	X	X		X	X	
NS	CMH-21	Low Ambient Control (Flare) ①			X			X
NS	3000-1224	Molded Compressor Plug	X			X		
NS	3000-1231	Molded Compressor Plug		X	X		X	X
NS	8408-039	Discharge Line Thermostat	X	X	X	X	X	X
NS	8408-048	Freeze Thermostat	X	X	X	X	X	X

NS – Not Shown

① – Optional

# FUNCTIONAL COMPONENTS

Dwg. No.	Part Number	Description	T48H1-A	T48H1-B	T48H1-C	T60H1-A	T60H1-B	T60H1-C
1	8000-332	Compressor	X					
1	8000-333	Compressor		X				
1	8000-334	Compressor			X			
1	8000-324	Compressor				X		
1	8000-325	Compressor					X	
1	8000-326	Compressor						X
2	S900-273-0011	Blower Assembly	X	X	X			
2	S900-273-0010	Blower Assembly				X	X	X
3	8200-004	Fan Motor Mount	X	X	X	X	X	X
4	5151-027	Fan Blade	X	X	X	X	X	X
5	8105-068	Condenser Motor	X	X				
5	8105-071	Condenser Motor			X			
5	8106-053	Condenser Motor				X	X	X
6	5051-169BX	Condenser Coil	X	X	X	X	X	X
7	800-0415	Cooling Distributor	X	X	X			
7	800-0416	Cooling Distributor				X	X	X
8	917-0190BX	Evaporator Coil	X	X	X	X	X	X
9	7004-016	Air Filter 1" Throw-Away	X	X	X	X	X	X
9	7004-049	Air Filter 2" Pleated MERV 11 ①	X	X	X	X	X	X
9	7004-031	Air Filter 2" Pleated MERV 8 ①	X	X	X	X	X	X
9	7004-027	Air Filter 2" Pleated MERV 6 ①	X	X	X	X	X	X
10	1171-022	1/4" Turn Fastener	X	X	X	X	X	X
11	1171-024	1/4" Turn Retainer	X	X	X	X	X	X
12	1171-023	1/4" Receptacle	X	X	X	X	X	X
13	5650-040	Reversing Valve with 24V Solenoid Coil	X	X	X	X	X	X
14	5650-042	Rev. Valve Solenoid, Red Casing (Ranco)	X	X	X	X	X	X
14	5650-043	Rev. Valve Solenoid, Black Casing (Wilspec)	X	X	X	X	X	X
14	5650-046	Rev. Valve Solenoid, Black Casing (San Hua)	X	X	X	X	X	X
15	5650-037	Molded Plug 3/6" Lead	X	X	X	X	X	X
17	8620-225	Defrost Sensor	X	X	X	X	X	X
19	1804-0462	High Pressure Switch (Flare) ①	X	X	X	X	X	X
20	800-0414	Heating Distributor Assembly	X	X	X	X	X	X
21	5651-184	Expansion Valve Heating	X	X	X			
21	5651-199	Expansion Valve Heating				X	X	X
22	5201-010	Filter Drier	X	X	X	X	X	X
NS	1804-0107	Low Pressure Switch (Flare) ①	X	X	X	X	X	X
NS	CMH-19	Low Ambient Control (Flare) ①				X	X	X
NS	CMH-20	Low Ambient Control (Flare) ①	X	X	X			
NS	3000-1224	Molded Compressor Plug	X			X		
NS	3000-1231	Molded Compressor Plug		X	X		X	X
NS	8408-039	Discharge Line Thermostat	X	X	X	X	X	X

NS – Not Shown

① – Optional



# FUNCTIONAL COMPONENTS

Dwg. No.	Part Number	Description	T48H1DA	T48H1DB	T48H1DC	T60H1DA	T60H1DB	T60H1DC
1	8000-332	Compressor	X					
1	8000-333	Compressor		X				
1	8000-334	Compressor			X			
1	8000-324	Compressor				X		
1	8000-325	Compressor					X	
1	8000-326	Compressor						X
2	S900-273-0011	Blower Assembly	X	X	X			
2	S900-273-0010	Blower Assembly				X	X	X
3	8200-004	Fan Motor Mount	X	X	X	X	X	X
4	5151-027	Fan Blade	X	X	X	X	X	X
5	8105-068	Condenser Motor	X	X				
5	8105-071	Condenser Motor			X			
5	8106-053	Condenser Motor				X	X	X
6	5051-169BX	Condenser Coil	X	X	X	X	X	X
7	800-0417	Cooling Distributor	X	X	X	X	X	X
8	917-0193BX	Evaporator Coil	X	X	X	X	X	X
9	7004-016	Air Filter 1" Throw-Away	X	X	X	X	X	X
9	7004-049	Air Filter 2" Pleated MERV 11 ①	X	X	X	X	X	X
9	7004-031	Air Filter 2" Pleated MERV 8 ①	X	X	X	X	X	X
9	7004-027	Air Filter 2" Pleated MERV 6 ①	X	X	X	X	X	X
10	1171-022	1/4" Turn Fastener	X	X	X	X	X	X
11	1171-024	1/4" Turn Retainer	X	X	X	X	X	X
12	1171-023	1/4" Receptacle	X	X	X	X	X	X
13	5650-040	Reversing Valve with 24V Solenoid Coil	X	X	X	X	X	X
14	5650-042	Rev. Valve Solenoid, Red Casing (Ranco)	X	X	X	X	X	X
14	5650-043	Rev. Valve Solenoid, Black Casing (Wilspec)	X	X	X	X	X	X
14	5650-046	Rev. Valve Solenoid, Black Casing (San Hua)	X	X	X	X	X	X
15	5650-037	Molded Plug 3/6" Lead	X	X	X	X	X	X
17	8620-225	Defrost Sensor	X	X	X	X	X	X
18	5651-228	Expansion Valve Cooling	X	X	X			
18	5651-199	Expansion Valve Cooling				X	X	X
19	1804-0462	High Pressure Switch (Flare) ①	X	X	X	X	X	X
20	800-0414	Heating Distributor Assembly	X	X	X	X	X	X
21	5651-184	Expansion Valve Heating	X	X	X			
21	5651-199	Expansion Valve Heating				X	X	X
22	5201-010	Filter Drier	X	X	X	X	X	X
NS	800-0410	Orifice Assembly	X	X	X	X	X	X
NS	5650-045	3-Way Valve	X	X	X	X	X	X
NS	5651-146	Check Valve	X	X	X	X	X	X
NS	1804-0107	Low Pressure Switch (Flare) ①	X	X	X	X	X	X
NS	CMH-19	Low Ambient Control (Flare) ①				X	X	X
NS	CMH-20	Low Ambient Control (Flare) ①	X	X	X			
NS	3000-1224	Molded Compressor Plug	X			X		
NS	3000-1231	Molded Compressor Plug		X	X		X	X
NS	8408-039	Discharge Line Thermostat	X	X	X	X	X	X
NS	8408-038	Freeze Thermostat	X	X	X	X	X	X

NS – Not Shown

① – Optional

# CONTROL PANEL

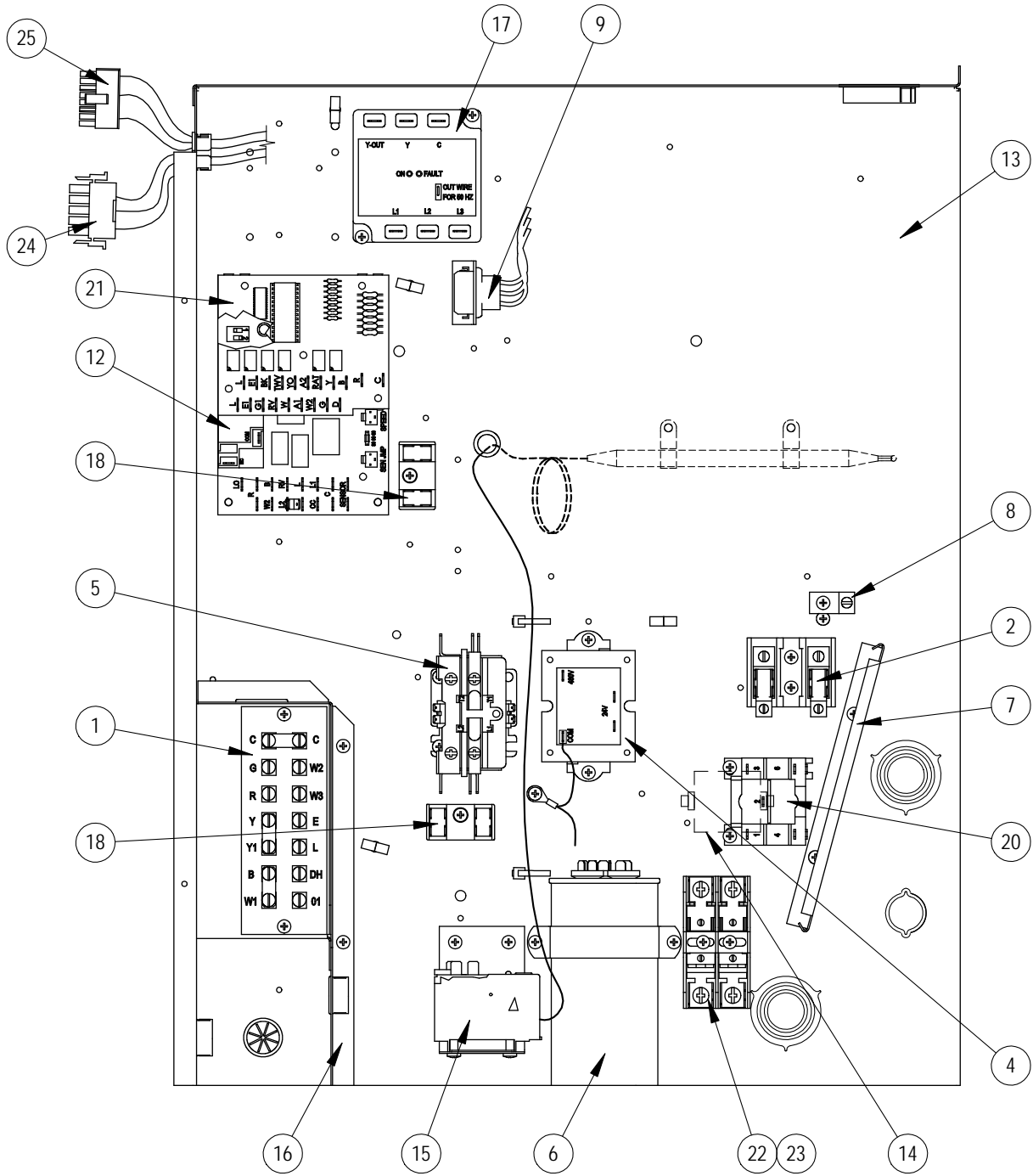

SEXP-605

# CONTROL PANEL

Dwg. No.	Part Number	Description	T36H1-A	T36H1-B	T36H1-C	T42H1-A	T42H1-B	T42H1-C	T36H1DA	T36H1DB	T36H1DC	T42H1DA	T42H1DB	T42H1DC
1	8607-031	Low Voltage Terminal Strip	X	X	X	X	X	X	X	X	X	X	X	X
2	8607-013	Terminal Block 2 Pole	X			X			X			X		
2	8607-014	Terminal Block 3 Pole		X	X		X	X		X	X		X	X
2	8607-015	Phenolic Insulator			X			X			X			X
4	8407-068	Transformer	X	X		X	X							
4	8407-069	Transformer			X			X						
4	8407-065	Transformer 240V							X	X		X	X	
4	8407-050	Transformer 480V									X			X
5	8401-002	Compressor Contactor		X	X		X	X		X	X		X	X
5	8401-025	Compressor Contactor	X			X			X			X		
6	8552-005	Outdoor Motor Capacitor		X			X			X			X	
6	8552-079	Compressor Capacitor	X			X			X			X		
6	8552-004	Outdoor Motor Capacitor			X			X			X			X
7	135-130	Wire Shield	X	X	X	X	X	X	X	X	X	X	X	X
8	8611-006	Ground Terminal	X	X	X	X	X	X	X	X	X	X	X	X
9	3000-1324	6 Pin Connector	X	X	X	X	X	X						
9	3000-1344	6 Pin Connector							X	X	X	X	X	X
10	8201-086	Low Ambient Bypass Relay ①	X	X	X	X	X	X	X	X	X	X	X	X
12	8620-223	Defrost Board Replacement Kit	X	X	X	X	X	X	X	X	X	X	X	X
13	117-289	Control Panel (Sheet Metal Only)	X	X	X	X	X	X	X	X	X	X	X	X
14	8551-004	Start Device ① PTCR	X			X			X			X		
15	8408-037	Return Air Thermostat							X	X	X	X	X	X
16	117X139	Low Voltage Box	X	X	X	X	X	X	X	X	X	X	X	X
17	8201-126	Phase Monitor		X	X		X	X		X	X		X	X
18	8607-017	Terminal Block ①	X	X	X	X	X	X	X	X	X	X	X	X
20	8201-032	Outdoor Fan Relay			X			X			X			X
21	8201-113	Dehumidification Logic Board							X	X	X	X	X	X
22	8614-041	Fuse Block			X			X			X			X
23	8614-046	Fuse			2			2			2			2
24	3000-1221	Blower Wire Harness Power							X	X	X	X	X	X
25	3000-1323	Blower Wire Harness Control							X	X	X	X	X	X
NS	4096-154	Wiring Diagram	X			X								
NS	4096-254	Wiring Diagram		X			X							
NS	4096-355	Wiring Diagram			X			X						
NS	4096-155	Wiring Diagram							X			X		
NS	4096-255	Wiring Diagram								X			X	
NS	4096-356	Wiring Diagram									X			X
NS	8615-055	Circuit Breaker 40A 2 Pole (OZ)	X			X			X					
NS	8615-052	Circuit Breaker 35A 3 Pole (OZ)		X			X			X				
NS	8615-041	Circuit Breaker 60A 2 Pole (OZ)										X		
NS	8615-043	Circuit Breaker 40A 3 Pole (OZ)											X	
NS	S8615-068	Rotary Disconnect (OZ)			X			X			X			X

NS – Not Shown  
 ① – Optional

# CONTROL PANEL

Dwg. No.	Part Number	Description	T48H1-A	T48H1-B	T48H1-C	T60H1-A	T60H1-B	T60H1-C	T48H1DA	T48H1DB	T48H1DC	T60H1DA	T60H1DB	T60H1DC
1	8607-031	Low Voltage Terminal Strip	X	X	X	X	X	X	X	X	X	X	X	X
2	8607-013	Terminal Block 2 Pole	X			X			X			X		
2	8607-014	Terminal Block 3 Pole		X	X		X	X		X	X		X	X
2	8607-015	Phenolic Insulator			X			X			X			X
4	8407-068	Transformer	X	X		X	X							
4	8407-069	Transformer			X			X						
4	8407-048	Transformer 240V							X	X		X	X	
4	8407-050	Transformer 480V									X			X
5	8401-002	Compressor Contactor		X	X		X	X		X	X		X	X
5	8401-025	Compressor Contactor	X			X			X			X		
6	8552-005	Outdoor Motor Capacitor		X					X	X				
6	8552-089	Compressor Capacitor	X											
6	8552-004	Outdoor Motor Capacitor			X						X			
6	8552-088	Compressor Capacitor				X						X		
7	135-130	Wire Shield	X	X	X	X	X	X	X	X	X	X	X	X
8	8611-006	Ground Terminal	X	X	X	X	X	X	X	X	X	X	X	X
9	3000-1324	6 Pin Connector	X	X	X	X	X	X		X	X	X	X	X
9	3000-1344	6 Pin Connector							X	X	X	X	X	X
10	8201-086	Low Ambient Bypass Relay ①	X	X	X	X	X	X	X	X	X	X	X	X
12	8620-223	Defrost Board Replacement Kit	X	X	X	X	X	X	X	X	X	X	X	X
13	117-309	Control Panel (Sheet Metal Only)	X	X	X	X	X	X	X	X	X	X	X	X
14	8551-004	Start Device ① PTCR	X			X			X			X		
15	8408-037	Return Air Thermostat							X	X	X	X	X	X
16	117-312	Low Voltage Box	X	X	X	X	X	X	X	X	X	X	X	X
17	8201-126	Phase Monitor		X	X		X	X		X	X		X	X
18	8607-017	Terminal Block ①	X	X	X	X	X	X	X	X	X	X	X	X
20	8201-032	Outdoor Fan Relay			X			X						
21	8201-113	Dehumidification Logic Board							X	X	X	X	X	X
22	8614-041	Fuse Block			X						X			
23	8614-046	Fuse			2			2			2			2
23	8614-042	Fuse						2						2
24	3000-1221	Blower Wire Harness Power	X	X	X	X	X	X	X	X	X	X	X	X
25	3000-1323	Blower Wire Harness Control	X	X	X	X	X	X	X	X	X	X	X	X
NS	4096-154	Wiring Diagram	X											
NS	4096-254	Wiring Diagram		X										
NS	4096-355	Wiring Diagram			X									
NS	4096-158	Wiring Diagram				X								
NS	4096-256	Wiring Diagram					X							
NS	4096-357	Wiring Diagram						X						
NS	4096-155	Wiring Diagram							X					
NS	4096-255	Wiring Diagram								X				
NS	4096-356	Wiring Diagram									X			
NS	4096-159	Wiring Diagram										X		
NS	4096-257	Wiring Diagram											X	
NS	4096-358	Wiring Diagram												X
NS	8615-040	Circuit Breaker 50A 2 Pole (OZ)	X						X					
NS	8615-041	Circuit Breaker 60A 2 Pole (OZ)				X						X		
NS	8615-043	Circuit Breaker 40A 3 Pole (OZ)		X			X			X			X	
NS	S8615-068	Rotary Disconnect (OZ)			X			X			X			X

NS – Not Shown

① – Optional

# BLOWER ASSEMBLY

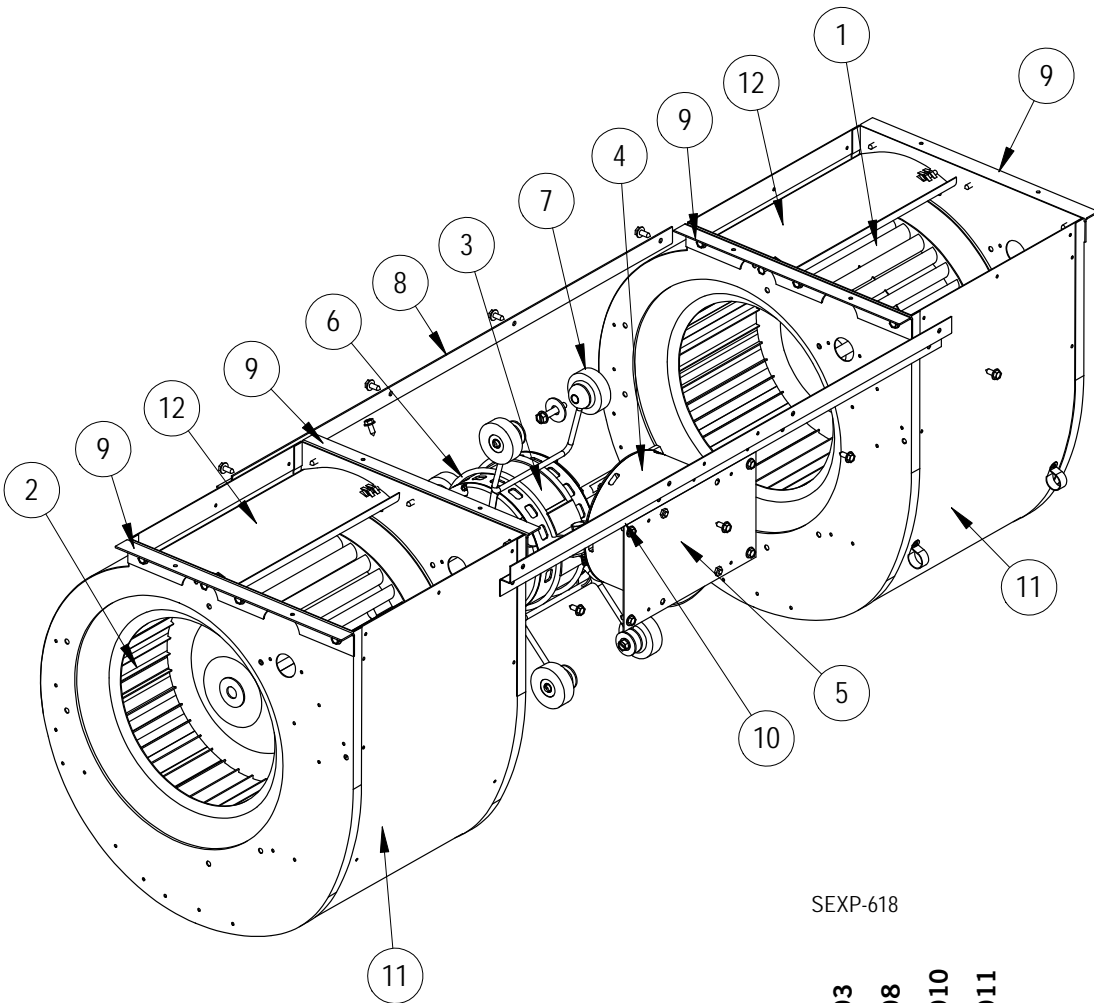

SEXP-618

Dwg. No.	Part Number	Description	S900-272-003	S900-273-008	S900-273-0010	S900-273-0011
1	5152-011	10-Inch Wheel (CW)	X	X	X	X
2	5152-012	10-Inch Wheel (CCW)	X	X	X	X
3	S8106-052-0065B	1/2 HP Programmed Motor	X			
3	S8107-017-0064A	3/4 HP Programmed Motor		X		
3	S8107-017-0086A	3/4 HP Programmed Motor			X	
3	S8107-017-0085A	3/4 HP Programmed Motor				X
4	C8106-052-0065B	Programmed Motor Control Only	X			
4	C8107-017-0064A	Programmed Motor Control Only		X		
4	C8107-017-0086A	Programmed Motor Control Only			X	
4	C8107-017-0085A	Programmed Motor Control Only				X
5	112-344	Blower Motor Control Bracket	X	X	X	X
6	8200-040	Motor Mount	X	X	X	X
7	5451-011	Grommets	6	6	6	6
8	105-881	Back Brace	X	X	X	X
9	105-880	Side Angle	4	4	4	4
10	103-389	Front Brace	X	X	X	X
11	151-101	Housing	2	2	2	2
12	144-166	Diffuser	2	2	2	2