

REPLACEMENT PARTS MANUAL

I-TEC SERIES PACKAGED HEAT PUMP

Models:

I30H1-A I30H1DA I36H1-A I36H1DA I42H1-A I42H1DA I48H1-A I48H1DA I60H1-A I60H1DA
 I30H1-B I30H1DB I36H1-B I36H1DB I42H1-B I42H1DB I48H1-B I48H1DB I60H1-B I60H1DB
 I30H1-C I30H1DC I36H1-C I36H1DC I24H1-C I42H1DC I48H1-C I48H1DC I60H1-C I60H1DC

Description	Page	Description	Page
Wiring Diagram Charts		Modulating CRV Control Panel Components	
♦ Matrix.....	2 - 3	♦ Exploded View.....	28
Cabinet Components		♦ Usage List.....	29
♦ Exploded View.....	4	ERV Components	
♦ Usage List.....	5	♦ Exploded View.....	30
Painted Cabinet Components		♦ Usage List.....	31
♦ Exploded View.....	6	ERV Control Panel Components	
♦ Usage List.....	7	♦ Exploded View.....	32
Functional Components		♦ Usage List.....	33
♦ Exploded View.....	8	ERV Cassette Components	
♦ Usage List.....	9	♦ Exploded View.....	34
♦ Usage List.....	10	♦ Usage List.....	35
Blower Assembly		CRV/ERV Blower Components	
♦ Exploded View.....	11	♦ Exploded View.....	36
♦ Usage List.....	11	♦ Usage List.....	37
Control Panel Components - 1 Phase		Sleeve Components	
♦ Exploded View.....	12	♦ Exploded View.....	38
♦ Usage List.....	13	♦ Usage List.....	39
Control Panel Components - 3 Phase		Riser Platform Components	
♦ Exploded View.....	14	♦ Exploded View.....	40
♦ Usage List.....	15	♦ Usage List.....	41
Control Panel Components - 460V 3 Phase			
♦ Exploded View.....	16	General Notes	
♦ Usage List.....	17	➤ Revised and/or additional pages may be issued from time to time.	
Electric Heater Components		➤ A complete and current manual consists of pages shown in the following contents section.	
♦ Exploded View.....	18		
♦ Usage Lists.....	19 - 21	Important	
Vent Box (Only) Components		➤ Contact the installing and/or local Bard distributor for all parts requirements. Be sure to have the complete model and serial number available from the unit rating plates.	
♦ Exploded View.....	22		
♦ Usage List.....	23		
CRV Components			
♦ Exploded View.....	24		
♦ Usage List.....	25		
Modulating CRV Components			
♦ Exploded View.....	26		
♦ Usage List.....	27		



Bard Manufacturing Company, Inc.
 Bryan, Ohio 43506
 www.bardhvac.com

Manual: 2110-585T
 Supersedes: 2110-585S
 Date: 3-25-15
REVISED: 1-23-23

I**H1 SERIES WIRING DIAGRAM MATRIX

Model	Wiring Diagram	Ventilation Package	Wiring Diagram	Heater	Wiring Diagram
I30H1-A	4202-101G	Commercial Room Ventilator	4204-103A	0KW	4203-100B
		Energy Recovery Ventilator	4204-104B	5KW	4203-101B
		Economizer	4204-105	10KW	4203-103B
		Modulating Commercial Room Ventilator	4204-106		
I30H1-B	4202-201G	Commercial Room Ventilator	4204-103A	0KW	4203-200B
		Energy Recovery Ventilator	4204-104B	6KW	4203-201C
		Economizer	4204-105	9KW	4203-201C
		Modulating Commercial Room Ventilator	4204-106		
I30H1-C	4202-301G	Commercial Room Ventilator	4204-103A	0KW	4203-300C
		Energy Recovery Ventilator	4204-104B	6KW	4203-301D
		Economizer	4204-105	9KW	4203-301D
		Modulating Commercial Room Ventilator	4204-106		
I36H1-A	4202-101G	Commercial Room Ventilator	4204-103A	0KW	4203-100B
		Energy Recovery Ventilator	4204-104B	5KW	4203-101B
		Economizer	4204-105	10KW	4203-103B
		Modulating Commercial Room Ventilator	4204-106	15KW	4203-104B
I36H1-B	4202-201G	Commercial Room Ventilator	4204-103A	0KW	4203-200B
		Energy Recovery Ventilator	4204-104B	6KW	4203-201C
		Economizer	4204-105	9KW	4203-201C
		Modulating Commercial Room Ventilator	4204-106	15KW	4203-202B
I36H1-C	4202-301G	Commercial Room Ventilator	4204-103A	0KW	4203-300C
		Energy Recovery Ventilator	4204-104B	6KW	4203-301D
		Economizer	4204-105	9KW	4203-301D
		Modulating Commercial Room Ventilator	4204-106	15KW	4203-302D
I42H1-A	4202-101G	Commercial Room Ventilator	4204-103A	0KW	4203-100B
		Energy Recovery Ventilator	4204-104B	5KW	4203-101B
		Economizer	4204-105	10KW	4203-103B
		Modulating Commercial Room Ventilator	4204-106	15KW	4203-104B
I42H1-B	4202-201G	Commercial Room Ventilator	4204-103A	0KW	4203-200B
		Energy Recovery Ventilator	4204-104B	6KW	4203-201C
		Economizer	4204-105	9KW	4203-201C
		Modulating Commercial Room Ventilator	4204-106	15KW	4203-202B
I42H1-C	4202-301G	Commercial Room Ventilator	4204-103A	0KW	4203-300A
		Energy Recovery Ventilator	4204-104B	6KW	4203-301D
		Economizer	4204-105	9KW	4203-301D
		Modulating Commercial Room Ventilator	4204-106	15KW	4203-302D
I48H1-A	4202-101G	Commercial Room Ventilator	4204-103A	0KW	4203-100B
		Energy Recovery Ventilator	4204-104B	4KW	4203-101B
		Economizer	4204-105	5KW	4203-102B
		Modulating Commercial Room Ventilator	4204-106	10KW	4203-103B
				15KW	4203-104B
				20KW	4203-105B
I48H1-B	4202-201G	Commercial Room Ventilator	4204-103A	0KW	4203-200B
		Energy Recovery Ventilator	4204-104B	6KW	4203-201C
		Economizer	4204-105	9KW	4203-201C
		Modulating Commercial Room Ventilator	4204-106	15KW	4203-202B
				18KW	4203-202B
I48H1-C	4202-301G	Commercial Room Ventilator	4204-103A	0KW	4203-300C
		Energy Recovery Ventilator	4204-104B	6KW	4203-301D
		Economizer	4204-105	9KW	4203-301D
		Modulating Commercial Room Ventilator	4204-106	15KW	4203-302D
				18KW	4203-302D
I60H1-A	4202-101G	Commercial Room Ventilator	4204-103A	0KW	4203-100B
		Energy Recovery Ventilator	4204-104B	4KW	4203-101B
		Economizer	4204-105	5KW	4203-102B
		Modulating Commercial Room Ventilator	4204-106	10KW	4203-103B
				15KW	4203-104B
				20KW	4203-105B
I60H1-B	4202-201G	Commercial Room Ventilator	4204-103A	0KW	4203-200B
		Energy Recovery Ventilator	4204-104B	6KW	4203-201C
		Economizer	4204-105	9KW	4203-201C
		Modulating Commercial Room Ventilator	4204-106	15KW	4203-202B
				18KW	4203-203B
I60H1-C	4202-301G	Commercial Room Ventilator	4204-103A	0KW	4203-300C
		Energy Recovery Ventilator	4204-104B	6KW	4203-301D
		Economizer	4204-105	9KW	4203-301D
		Modulating Commercial Room Ventilator	4204-106	15KW	4203-302D
				18KW	4203-302D

I*H1 SERIES WIRING DIAGRAM MATRIX

Model	Wiring Diagram	Ventilation Package	Wiring Diagram	Heater	Wiring Diagram
I30H1DA	4202-102G	Commercial Room Ventilator	4204-103A	0KW	4203-100B
		Energy Recovery Ventilator	4204-104B	5KW	4203-101B
		Economizer	4204-105	10KW	4203-103B
		Modulating Commercial Room Ventilator	4204-106		
I30H1DB	4202-202G	Commercial Room Ventilator	4204-103A	0KW	4203-200B
		Energy Recovery Ventilator	4204-104B	6KW	4203-201C
		Economizer	4204-105	9KW	4203-201C
		Modulating Commercial Room Ventilator	4204-106		
I30H1DC	4202-302G	Commercial Room Ventilator	4204-103A	0KW	4203-300C
		Energy Recovery Ventilator	4204-104B	6KW	4203-301D
		Economizer	4204-105	9KW	4203-301D
		Modulating Commercial Room Ventilator	4204-106		
I36H1DA	4202-102G	Commercial Room Ventilator	4204-103A	0KW	4203-100B
		Energy Recovery Ventilator	4204-104B	5KW	4203-101B
		Economizer	4204-105	10KW	4203-103B
		Modulating Commercial Room Ventilator	4204-106	15KW	4203-104B
I36H1DB	4202-202G	Commercial Room Ventilator	4204-103A	0KW	4203-200B
		Energy Recovery Ventilator	4204-104B	6KW	4203-201C
		Economizer	4204-105	9KW	4203-201C
		Modulating Commercial Room Ventilator	4204-106	15KW	4203-202B
I36H1DC	4202-302G	Commercial Room Ventilator	4204-103A	0KW	4203-300C
		Energy Recovery Ventilator	4204-104B	6KW	4203-301D
		Economizer	4204-105	9KW	4203-301D
		Modulating Commercial Room Ventilator	4204-106	15KW	4203-302D
I42H1DA	4202-102G	Commercial Room Ventilator	4204-103A	0KW	4203-100B
		Energy Recovery Ventilator	4204-104B	5KW	4203-101B
		Economizer	4204-105	10KW	4203-103B
		Modulating Commercial Room Ventilator	4204-106	15KW	4203-104B
I42H1DB	4202-202G	Commercial Room Ventilator	4204-103A	0KW	4203-200B
		Energy Recovery Ventilator	4204-104B	6KW	4203-201C
		Economizer	4204-105	9KW	4203-201C
		Modulating Commercial Room Ventilator	4204-106	15KW	4203-202B
I42H1DC	4202-302G	Commercial Room Ventilator	4204-103A	0KW	4203-300C
		Energy Recovery Ventilator	4204-104B	6KW	4203-301D
		Economizer	4204-105	9KW	4203-301D
		Modulating Commercial Room Ventilator	4204-106	15KW	4203-302D
I48H1DA	4202-102G	Commercial Room Ventilator	4204-103A	0KW	4203-100B
		Energy Recovery Ventilator	4204-104B	4KW	4203-101B
		Economizer	4204-105	5KW	4203-102B
		Modulating Commercial Room Ventilator	4204-106	10KW	4203-103B
				15KW	4203-104B
				20KW	4203-105B
I48H1DB	4202-202G	Commercial Room Ventilator	4204-103A	0KW	4203-200B
		Energy Recovery Ventilator	4204-104B	6KW	4203-201C
		Economizer	4204-105	9KW	4203-201C
		Modulating Commercial Room Ventilator	4204-106	15KW	4203-202B
				18KW	4203-202B
I48H1DC	4202-302G	Commercial Room Ventilator	4204-103A	0KW	4203-300C
		Energy Recovery Ventilator	4204-104B	6KW	4203-301D
		Economizer	4204-105	9KW	4203-301D
		Modulating Commercial Room Ventilator	4204-106	15KW	4203-302D
				18KW	4203-302D
I60H1DA	4202-102G	Commercial Room Ventilator	4204-103A	0KW	4203-100B
		Energy Recovery Ventilator	4204-104B	4KW	4203-101B
		Economizer	4204-105	5KW	4203-102B
		Modulating Commercial Room Ventilator	4204-106	10KW	4203-103B
				15KW	4203-104B
				20KW	4203-105B
I60H1DB	4202-202G	Commercial Room Ventilator	4204-103A	0KW	4203-200B
		Energy Recovery Ventilator	4204-104B	6KW	4203-201C
		Economizer	4204-105	9KW	4203-201C
		Modulating Commercial Room Ventilator	4204-106	15KW	4203-202B
				18KW	4203-203B
I60H1DC	4202-302G	Commercial Room Ventilator	4204-103A	0KW	4203-300C
		Energy Recovery Ventilator	4204-104B	6KW	4203-301D
		Economizer	4204-105	9KW	4203-301D
		Modulating Commercial Room Ventilator	4204-106	15KW	4203-302D
				18KW	4203-302D

CABINET COMPONENTS

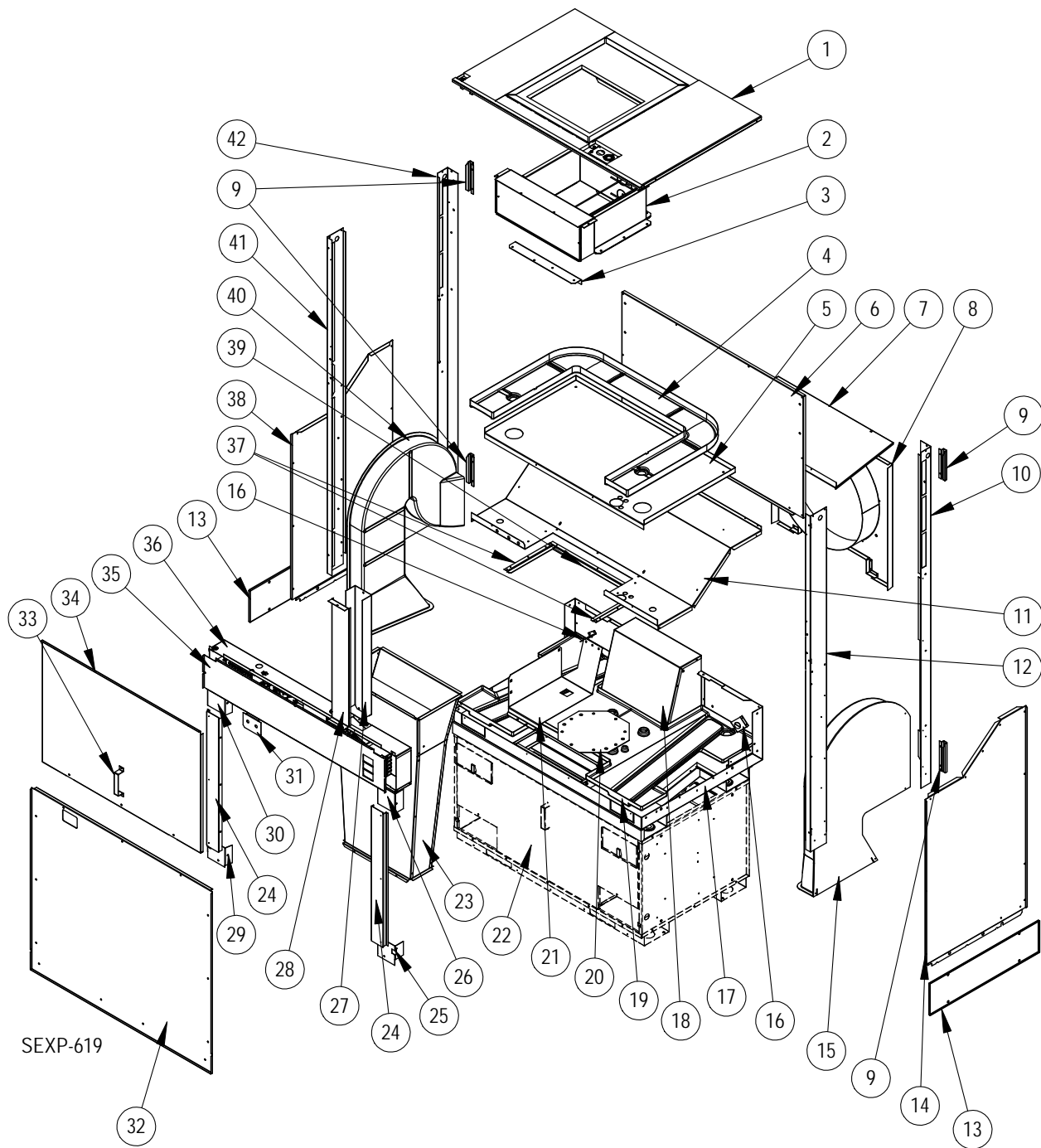

CABINET COMPONENTS

Drawing No.	Part Number	Description	All Models
1	S507-296	Top Assembly	X
2	See Heater Pkg. Section	Heater Package	X
3	105-1256	Front blower angle	X
4	6096-001	Indoor drain pan	X
5	S141-383	Evap. Coil Support	X
6	509-259-8	Unit Back Assembly	X
7	S137-641	Cond. Coil Top Fill	X
8	S125-065	Fan Shroud/Venturi Assembly	X
9	113-439	Side Bracket	4
10	S149-120	Right Rear Corner	X
11	S121-456	Condenser Partition	X
12	S149-123	Right Front Corner	X
13	S113-438	Unit Connection Bracket	2
14	S101X635	Right Inner Side Panel	X
15	S7001-024	Right Hand Inlet Duct (used on CRV & ERV units only)	X
16	113-429	Evap. Drain Tube Bracket	2
17	S127-416	Condenser Base Assembly	X
18	S921-0003	Exhaust Duct Assembly	X
19	6096-002	Outdoor Drain Pan	X
20	126-417	Compressor Mounting Base	X
21	113-595 113-449	460V trans. Mtg brkt. (136-42-48) 460V trans. Mtg brkt. (160 Only)	X X
22	See Vent Section	Vent Option	X
23	511-177	Intake Duct Assembly (used on CRV and ERV units only)	X
24	S141-391	Condenser Coil Access Door	X
25	S141X390	Lower Right Condenser Coil Support	X
26	S141X389	Upper Right Condenser Coil Support	X
27	165-599	High Voltage Wire Channel	X
28	143-157	High Voltage Wire Channel Cover	X
29	S141Y390	Lower Left Condenser Coil Support	X
30	S141Y389	Upper Left Condenser Coil Support	X
31	S113-440	Dual Service Port Bracket	X
32	S553-498	Condenser Door	X
33	113-441	Door Latch Bracket	X
34	S553-496	Evaporator Door	X
35	S153-497 S153-501	Control Panel Door (230V Units) Control Panel Door (460V Units)	X X
36	See Control Panel Section	Control Panel	X
37	103-493	Cond. Partition Side Offset	2
38	S101Y635	Left Inner Side Panel	X
39	103-494	Cond. Partition Rear Offset	X
40	S7001-025	Left Hand Inlet Duct (used on CRV & ERV units only)	X
41	S149-121	Left Front Corner	X
42	S149-122	Left Rear Corner	X
NS	S113-426	Top Mounting Bracket	X

NS = Not Shown

PAINTED CABINET COMPONENTS

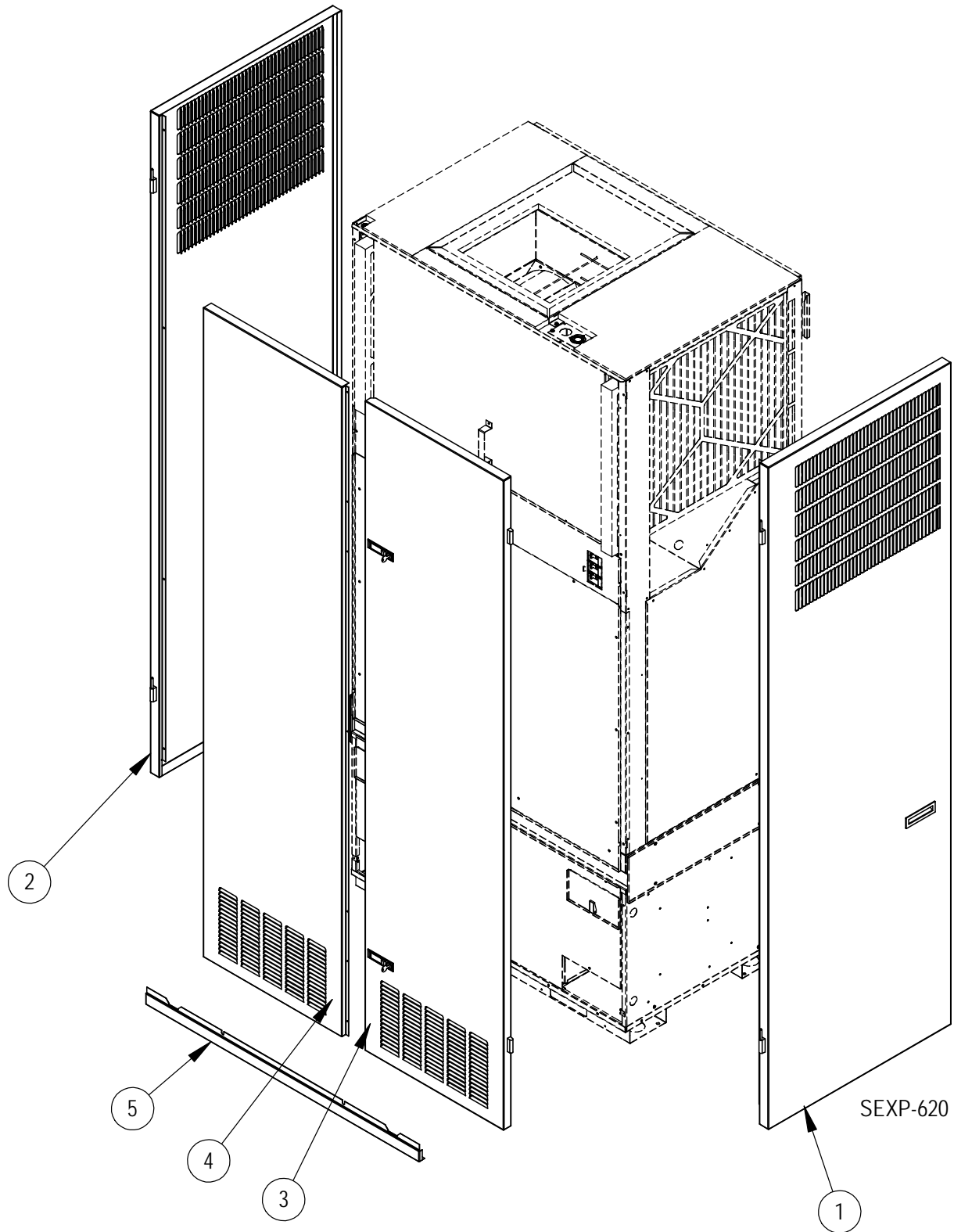

PAINTED CABINET COMPONENTS

Drawing No.	Part Number	Description	All Models
1	501-636-*	Right Side	X
2	501-637-*	Left Side	X
3	S553-500-*	Right Front Door	X
4	S553-499-*	Left Front Door	X
5	115-206-*	Front Unit Trim	X

* Exterior cabinet parts are manufactured with various paint color options. To ensure the proper paint color is received, reference the following codes:

Beige -X
White -1
Buckeye Gray -4

FUNCTIONAL COMPONENTS

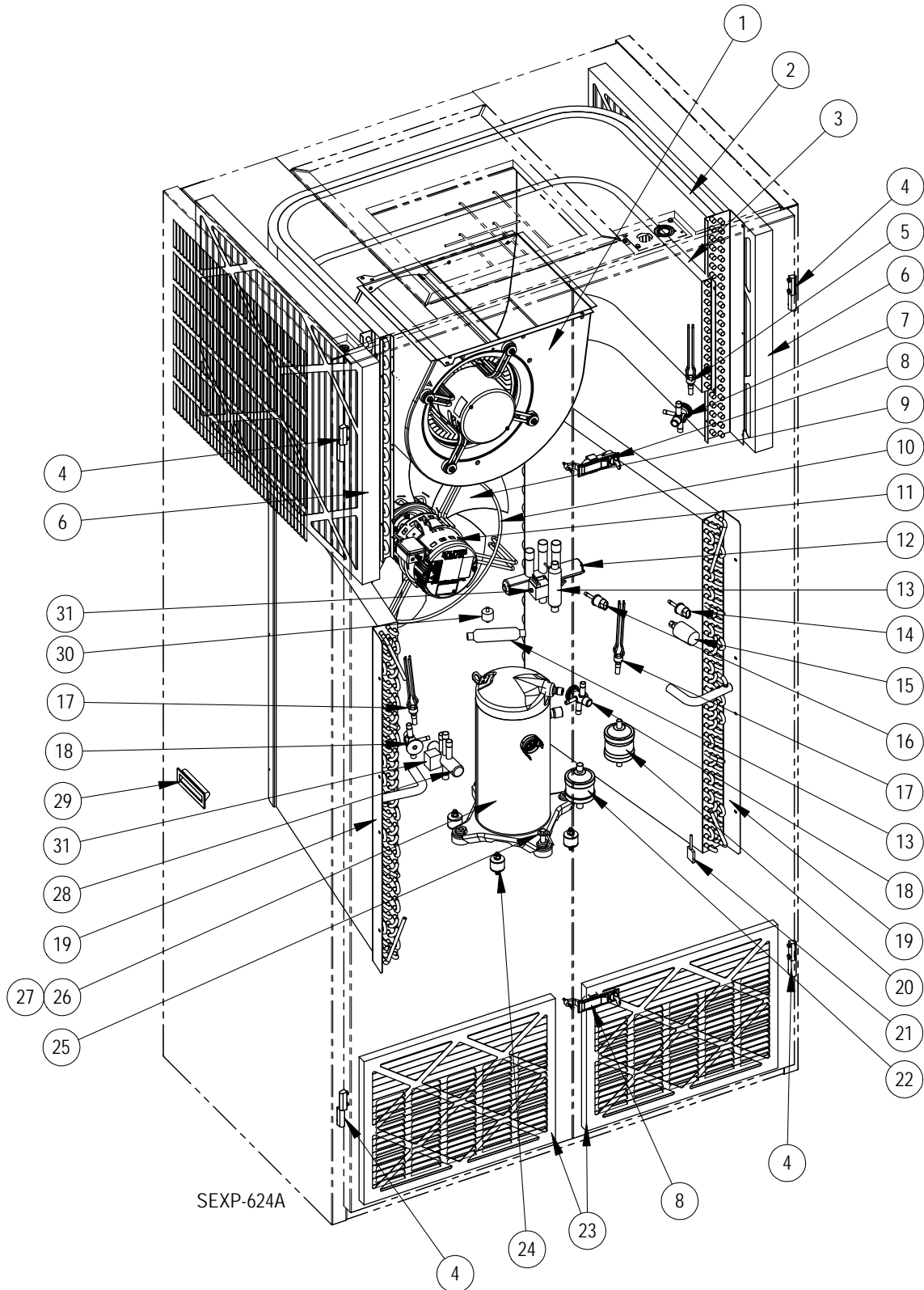

FUNCTIONAL COMPONENTS

Drawing No.	Part Number	Description	130H1-A	130H1-B	130H1-C	130H1A	130H1B	130H1C	136H1-A	136H1-B	136H1-C	136H1A	136H1B	136H1C	136H1DC	142H1-A	142H1-B	142H1-C	142H1A	142H1B	142H1DC	148H1-A	148H1-B	148H1-C	148H1A	148H1B	148H1DC	160H1-A	160H1-B	160H1-C	160H1A	160H1B	160H1DC				
22	5220-013	Pulsation Dampener/Muffler	X	X	X	X	X	X	X	X	X	X	X	X	X	X	X	X	X	X	X	X	X	X	X	X	X	X	X	X	X	X	X	X	X		
23	7004-003	Filter	2	4	4	4	4	4	4	4	4	4	4	4	4	4	4	4	4	4	4	4	4	4	4	4	4	4	4	4	4	4	4	4	4		
24	8001-013	Compressor Grommet	4	4	4	4	4	4	4	4	4	4	4	4	4	4	4	4	4	4	4	4	4	4	4	4	4	4	4	4	4	4	4	4	4	4	
25	1012-328	Compressor Bolt	4	4	4	4	4	4	4	4	4	4	4	4	4	4	4	4	4	4	4	4	4	4	4	4	4	4	4	4	4	4	4	4	4	4	
	8000-388		X																																		
	8000-389			X																																	
	8000-390				X																																
	8000-379					X																															
	8000-380						X																														
	8000-381							X																													
	8000-391								X																												
26	8000-392	Compressor								X																											
	8000-393										X																										
	8000-382																																				
	8000-383																																				
	8000-384																																				
	8000-385																																				
	8000-386																																				
	8000-387																																				
27	8002-012	Compressor Sound Cover	X	X	X	X	X	X	X	X	X	X	X	X	X	X	X	X	X	X	X	X	X	X	X	X	X	X	X	X	X	X	X	X	X	X	X
	8002-013																																				
28	5650-051	Dehum. Valve, 4-Pipe																																			
29	1171-060	Flush Plastic Door Pull	2	2	2	2	2	2	2	2	2	2	2	2	2	2	2	2	2	2	2	2	2	2	2	2	2	2	2	2	2	2	2	2	2	2	2
30	5451-018	Motor Mount Grommet	2	2	2	2	2	2	2	2	2	2	2	2	2	2	2	2	2	2	2	2	2	2	2	2	2	2	2	2	2	2	2	2	2	2	2
31	5650-046	Rev. Valve Solenoid - Black casing	X	X	X	X	X	X	X	X	X	X	X	X	X	X	X	X	X	X	X	X	X	X	X	X	X	X	X	X	X	X	X	X	X	X	X
NS	6094-011	3/4" Barbed Drain Pan Fitting	4	4	4	4	4	4	4	4	4	4	4	4	4	4	4	4	4	4	4	4	4	4	4	4	4	4	4	4	4	4	4	4	4	4	4
NS	6001-016	Nylon Barbed Tee	X	X	X	X	X	X	X	X	X	X	X	X	X	X	X	X	X	X	X	X	X	X	X	X	X	X	X	X	X	X	X	X	X	X	X
NS	7950-021	1" Hose Clamp	8	8	8	8	8	8	8	8	8	8	8	8	8	8	8	8	8	8	8	8	8	8	8	8	8	8	8	8	8	8	8	8	8	8	8

BLOWER ASSEMBLY COMPONENTS

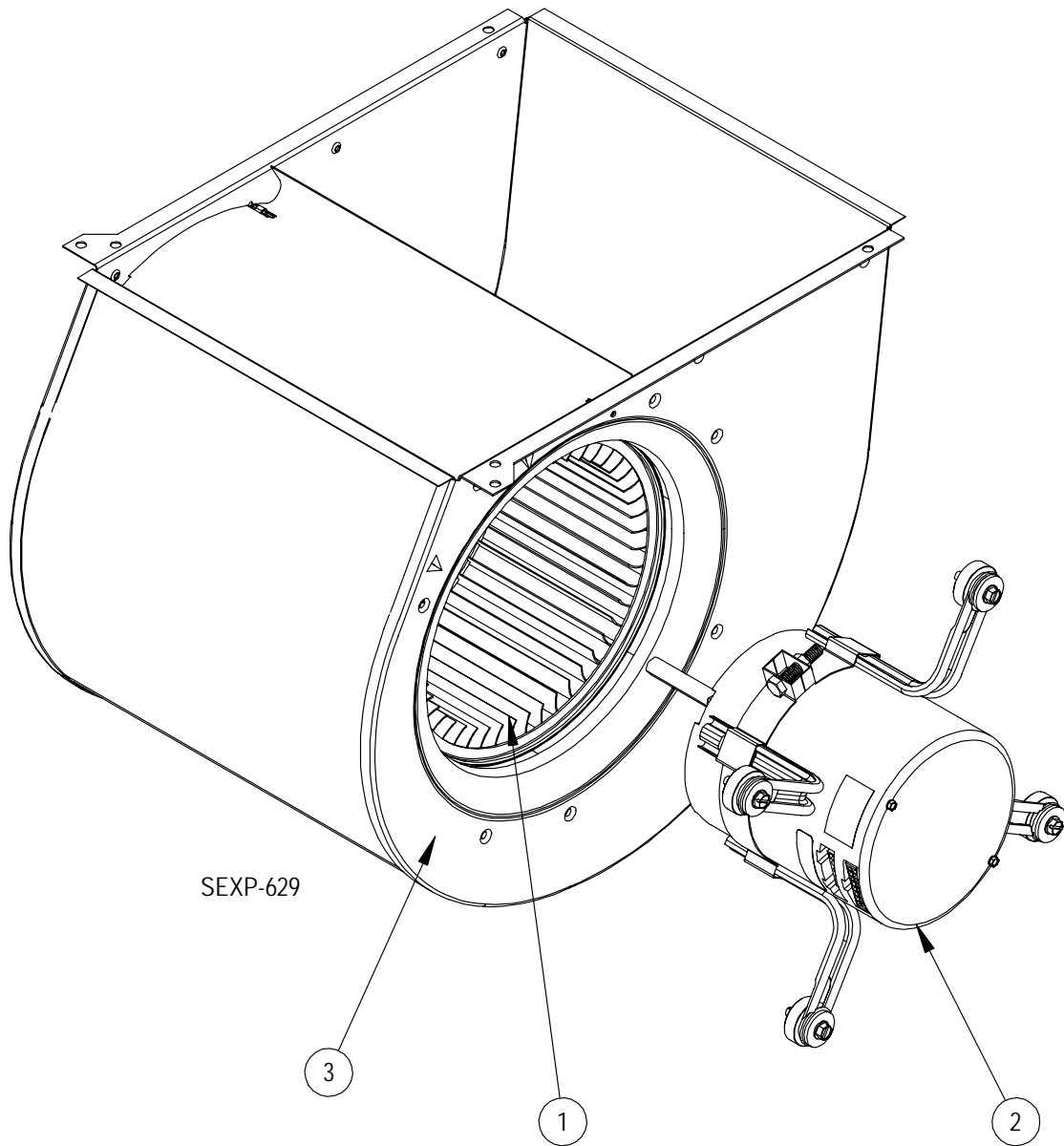

Drawing No.	Part Number	Description	5154-002-0090	5154-005-0089	5154-005-0088	5154-005-0087	5154-006-0081
1	5152-049	Blower Wheel	X	X	X	X	X
2	S8105-059-0090	1/3 HP Programmed Motor	X				
	S8106-051-0089	1/2 HP Programmed Motor		X			
	S8106-051-0088	1/2 HP Programmed Motor			X		
	S8106-051-0087	1/2 HP Programmed Motor				X	
	S8107-016-0081	3/4 HP Programmed Motor					X
3	151-122	Housing	X	X	X	X	X

CONTROL PANEL COMPONENTS - 1 PHASE

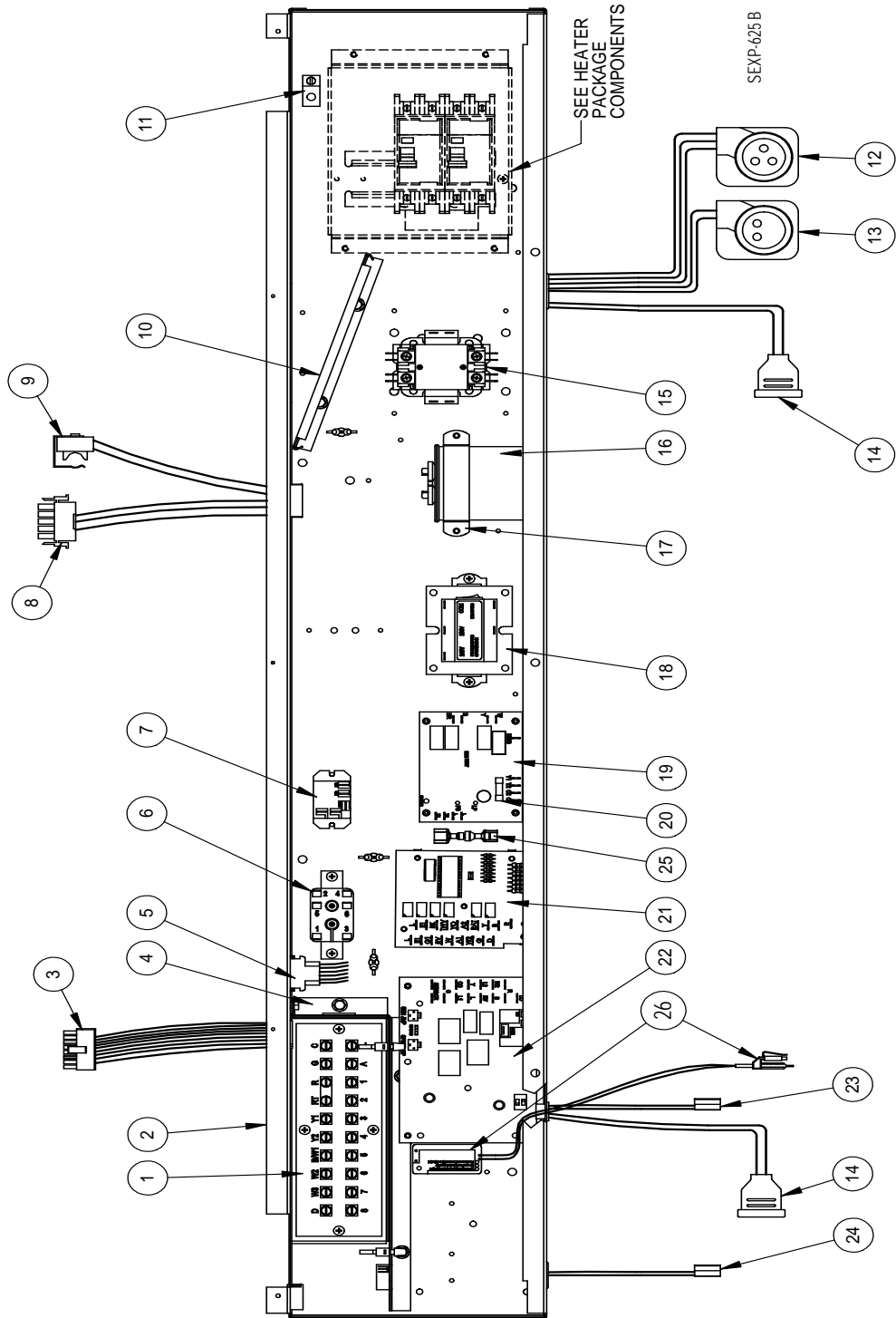

CONTROL PANEL COMPONENTS – 1 PHASE

Drawing No.	Part Number	Description	I30H1-A	I30H1DA	I36H1-A	I36H1DA	I42H1-A	I42H1DA	I48H1-A	I48H1DA	I60H1-A	I60H1DA
1	8607-032	Low Voltage Terminal Strip	X	X	X	X	X	X	X	X	X	X
2	517-318	Control Panel	X	X	X	X	X	X	X	X	X	X
3	3000-1396	16 pin 24V Indoor Blower Motor Control	X	X	X	X	X	X	X	X	X	X
4	117-319	Low Voltage terminal box	X	X	X	X	X	X	X	X	X	X
5	3000-1397	6 Pin Elect. Heat	X	X	X	X	X	X	X	X	X	X
6	8201-015	Relay	X	X	X	X	X	X	X	X	X	X
7	8201-130	Relay		X		X		X		X		X
8	3000-1398	5 Pin Indoor Blower Motor Power	X	X	X	X	X	X	X	X	X	X
9	8408-048	Freeze protect thermostat	X	X	X	X	X	X	X	X	X	X
10	135-319	Wire Shield	X	X	X	X	X	X	X	X	X	X
11	8611-006	Ground Terminal	X	X	X	X	X	X	X	X	X	X
12	3000-1222	Compressor Power Plug	X	X	X	X	X	X	X	X	X	X
13	3000-1223	Compressor Solenoid Plug	X	X	X	X	X	X	X	X	X	X
14	5650-044	Solenoid Valve plug	X	2	X	2	X	2	X	2	X	2
15	8401-025	Contactora 2 Pole 40 Amp	X	X	X	X	X	X	X	X	X	X
16	8552-035	Capacitor 40MFD 370V	X	X	X	X						
	8552-043	Capacitor 45MFD 370V					X	X				
	8552-095	Capacitor 30MFD 370V							X	X		
	8552-096	Capacitor 40MFD 440V									X	X
17	8550-007	Capacitor Bracket 2" Round	X	X	X	X					X	X
	8550-008	Capacitor Bracket 2-1/2" Round					X	X				
	8550-006	Capacitor Bracket 1-3/4" Round							X	X		
18	8407-048	Transformer 75VA with Circuit Breaker	X	X	X	X	X	X	X	X	X	X
19	8201-128	Fan Logic Control	X	X	X	X	X	X	X	X	X	X
20	8614-052	3.15 Amp Fuse	X	X	X	X	X	X	X	X	X	X
21	8201-113	Dehum Logic Board		X		X		X		X		X
22	8620-223	Defrost Control Board Kit (includes new sensor)	X	X	X	X	X	X	X	X	X	X
23	8620-225	Defrost Sensor Kit	X	X	X	X	X	X	X	X	X	X
24	8408-043	Fan Control Thermistor	X	X	X	X	X	X	X	X	X	X
25	910-1816	Fan Control Resistor (Optional)	X	X	X	X	X	X	X	X	X	X
26	910-1936	Overflow Switch Assembly	X	X	X	X	X	X	X	X	X	X

CONTROL PANEL COMPONENTS - 3 PHASE

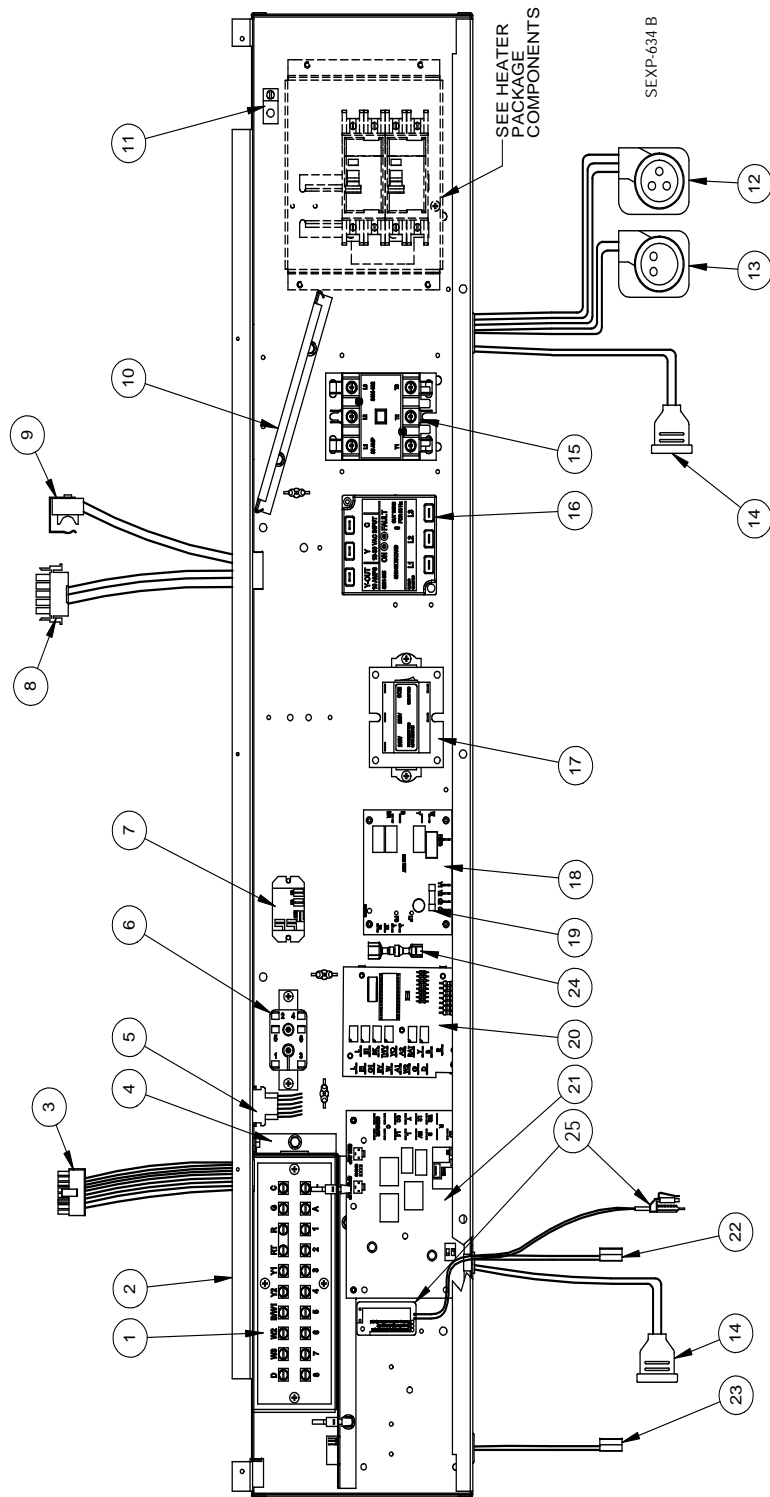

CONTROL PANEL COMPONENTS – 3 PHASE

Drawing No.	Part Number	Description	I30H1-B	I30H1DB	I36H1-B	I36H1DB	I42H1-B	I42H1DB	I48H1-B	I48H1DB	I60H1-B	I60H1DB
1	8607-032	Low Voltage Terminal Strip	X	X	X	X	X	X	X	X	X	X
2	517-318	Control Panel	X	X	X	X	X	X	X	X	X	X
3	3000-1396	16 pin 24V Indoor Blower Motor Control	X	X	X	X	X	X	X	X	X	X
4	117-319	Low Voltage Terminal Box	X	X	X	X	X	X	X	X	X	X
5	3000-1397	6 Pin Elect. Heat	X	X	X	X	X	X	X	X	X	X
6	8201-015	Relay	X	X	X	X	X	X	X	X	X	X
7	8201-130	Relay		X		X		X		X		X
8	3000-1398	5 Pin Indoor Blower Motor Power	X	X	X	X	X	X	X	X	X	X
9	8408-048	Freeze Protect Thermostat	X	X	X	X	X	X	X	X	X	X
10	135-319	Wire Shield	X	X	X	X	X	X	X	X	X	X
11	8611-006	Ground Terminal	X	X	X	X	X	X	X	X	X	X
12	3000-1231	Compressor Power Plug	X	X	X	X	X	X	X	X	X	X
13	3000-1223	Compressor Solenoid Plug	X	X	X	X	X	X	X	X	X	X
14	5650-044	Solenoid Valve Plug	X	2	X	2	X	2	X	2	X	2
15	8401-002	Contactora 3 Pole 25 Amp	X	X	X	X	X	X	X	X	X	X
16	8201-126	3-PH Line Monitor	X	X	X	X	X	X	X	X	X	X
17	8407-048	Transformer 75VA with Circuit Breaker	X	X	X	X	X	X	X	X	X	X
18	8201-128	Fan Logic Control	X	X	X	X	X	X	X	X	X	X
19	8614-052	3.15 Amp Fuse	X	X	X	X	X	X	X	X	X	X
20	8201-113	Dehum Logic Board		X		X		X		X		X
21	8620-223	Defrost Control Board Kit (includes new sensor)	X	X	X	X	X	X	X	X	X	X
22	8620-225	Defrost Sensor Kit	X	X	X	X	X	X	X	X	X	X
23	8408-043	Fan Control Thermistor	X	X	X	X	X	X	X	X	X	X
24	S910-1816	Fan Control Resistor (Optional)	X	X	X	X	X	X	X	X	X	X
25	910-1936	Overflow Switch Assembly	X	X	X	X	X	X	X	X	X	X

CONTROL PANEL COMPONENTS – 460V 3 PHASE

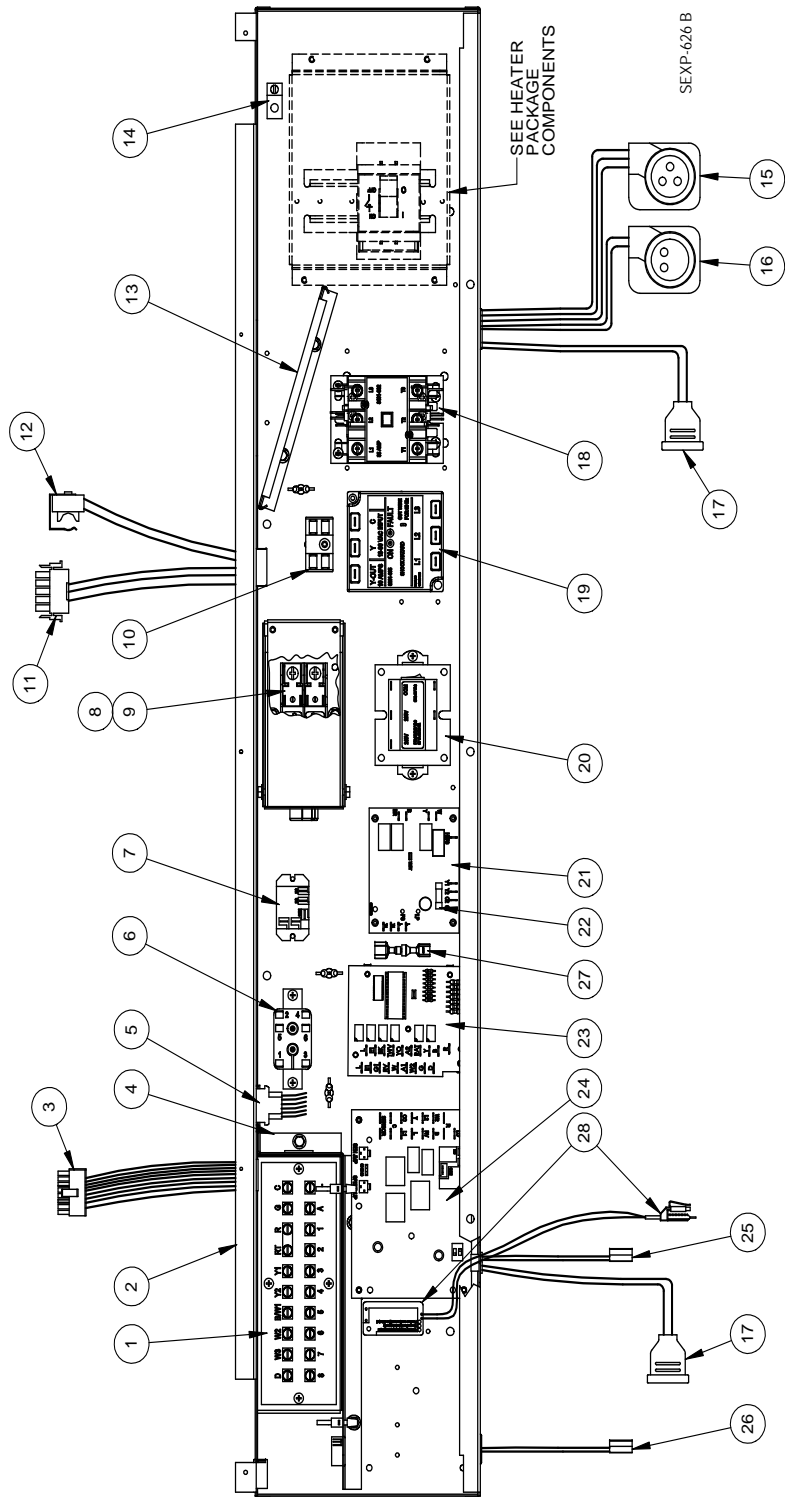

CONTROL PANEL COMPONENTS – 460V 3 PHASE

Drawing No.	Part Number	Description	I30H1-C	I30H1DC	I36H1-C	I36H1DC	I42H1-C	I42H1DC	I48H1-C	I48H1DC	I60H1-C	I60H1DC
1	8607-032	Low Voltage Terminal Strip	X	X	X	X	X	X	X	X	X	X
2	517-318	Control Panel	X	X	X	X	X	X	X	X	X	X
3	3000-1396	16 pin 24V Indoor Blower Motor Control	X	X	X	X	X	X	X	X	X	X
4	117-319	Low Voltage Terminal Box	X	X	X	X	X	X	X	X	X	X
5	3000-1397	6 Pin Elect. Heat	X	X	X	X	X	X	X	X	X	X
6	8201-015	Relay	X	X	X	X	X	X	X	X	X	X
7	8201-130	Relay		X		X		X		X		X
8	8614-041	Fuse Block	X	X	X	X	X	X	X	X	X	X
9	<i>See Separate Chart (Below) for Item #9</i>											
10	8607-017	Terminal Block	X	X	X	X	X	X	X	X	X	X
11	3000-1398	5 Pin Indoor Blower Motor Power	X	X	X	X	X	X	X	X	X	X
12	8408-048	Freeze Protect Thermostat	X	X	X	X	X	X	X	X	X	X
13	135-319	Wire Shield	X	X	X	X	X	X	X	X	X	X
14	8611-006	Ground Terminal	X	X	X	X	X	X	X	X	X	X
15	3000-1231	Compressor Power Plug	X	X	X	X	X	X	X	X	X	X
16	3000-1223	Compressor Solenoid Plug	X	X	X	X	X	X	X	X	X	X
17	5650-044	Solenoid Valve Plug	X	2	X	2	X	2	X	2	X	2
18	8401-002	Contactora 3 Pole 25 Amp	X	X	X	X	X	X	X	X	X	X
19	8201-126	3-PH Line Monitor	X	X	X	X	X	X	X	X	X	X
20	8407-048	Transformer 75VA with Circuit Breaker	X	X	X	X	X	X	X	X	X	X
21	8201-128	Fan Logic Control	X	X	X	X	X	X	X	X	X	X
22	8614-052	3.15 Amp Fuse	X	X	X	X	X	X	X	X	X	X
23	8201-113	Dehum Logic Board		X		X		X		X		X
24	8620-223	Defrost Control Board Kit (includes new sensor)	X	X	X	X	X	X	X	X	X	X
25	8620-225	Defrost Sensor Kit	X	X	X	X	X	X	X	X	X	X
26	8408-043	Fan Control Thermistor	X	X	X	X	X	X	X	X	X	X
27	S910-1816	Fan Control Resistor (Optional)	X	X	X	X	X	X	X	X	X	X
28	910-1936	Overflow Switch Assembly	X	X	X	X	X	X	X	X	X	X

		With Vent	No Vent
9	I30H1-C	(2) Part #8614-046 5A Class CC Fuse	(2) Part #8614-047 3.2A Class CC Fuse
	I30H1DC	(2) Part #8614-046 5A Class CC Fuse	(2) Part #8614-047 3.2A Class CC Fuse
	I36H1-C	(2) Part #8614-042 7A Class CC Fuse	(2) Part #8614-046 5A Class Fuse
	I36H1DC	(2) Part #8614-042 7A Class CC Fuse	(2) Part #8614-046 5A Class CC Fuse
	I42H1-C	(2) Part #8614-042 7A Class CC Fuse	(2) Part #8614-046 5A Class CC Fuse
	I42H1DC	(2) Part #8614-042 7A Class CC Fuse	(2) Part #8614-046 5A Class CC Fuse
	I48H1-C	(2) Part #8614-042 7A Class CC Fuse	(2) Part #8614-046 5A Class CC Fuse
	I48H1DC	(2) Part #8614-042 7A Class CC Fuse	(2) Part #8614-046 5A Class CC Fuse
	I60H1-C	(2) Part #8614-043 10A Class CC Fuse	(2) Part #8614-042 7A Class CC Fuse
	I60H1DC	(2) Part #8614-043 10A Class CC Fuse	(2) Part #8614-042 7A Class CC Fuse

ELECTRIC HEATER COMPONENTS

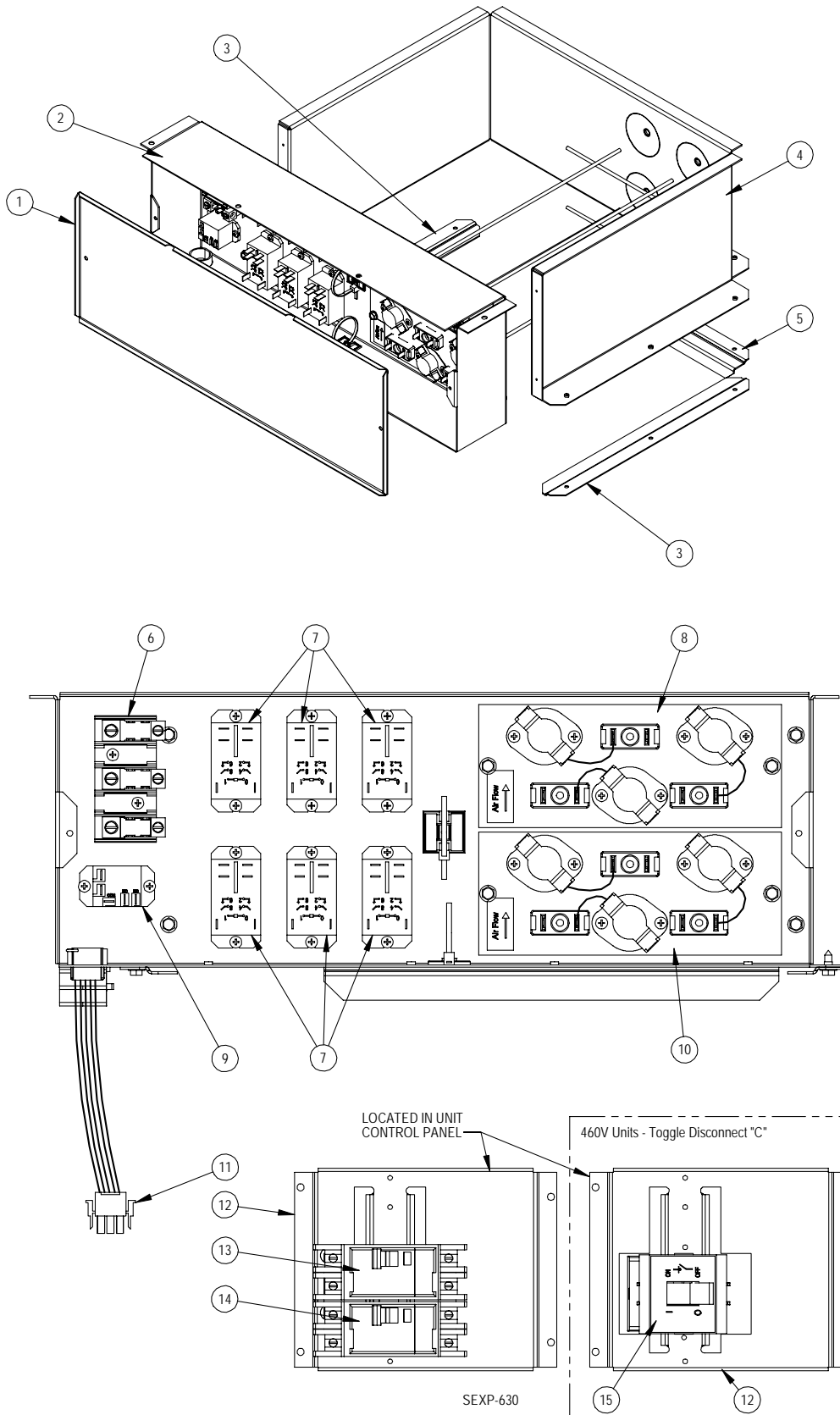

ELECTRIC HEATER COMPONENTS

Drawing No.	Part No.	Description	I30H1-A0Z, I30H1DA0Z	I30H1-A05, I30H1DA05	I30H1-A10, I30H1DA10	I36H1-A0Z, I36H1DA0Z	I36H1-A05, I36H1DA05	I36H1-A10, I36H1DA10	I36H1-A15, I36H1DA15	I42H1-A0Z, I42H1DA0Z	I42H1-A05, I42H1DA05	I42H1-A10, I42H1DA10	I42H1-A15, I42H1DA15	I48H1-A0Z, I48H1DA0Z	I48H1-A04, I48H1DA04	I48H1-A05, I48H1DA05	I48H1-A10, I48H1DA10	I48H1-A15, I48H1DA15	I48H1-A20, I48H1DA20	I60H1-A0Z, I60H1DA0Z	I60H1-A05, I60H1DA05	I60H1-A10, I60H1DA10	I60H1-A15, I60H1DA15	I60H1-A20, I60H1DA20
1	143-148	Heater Box Cover	X	X	X	X	X	X	X	X	X	X	X	X	X	X	X	X	X	X	X	X	X	X
2	117-313	Heater Front Plate	X	X	X	X	X	X	X	X	X	X	X	X	X	X	X	X	X	X	X	X	X	X
3	103-486	Side Blower Offset	2	2	2	2	2	2	2	2	2	2	2	2	2	2	2	2	2	2	2	2	2	2
4	117-307	Heater Wrapper	X	X	X	X	X	X	X	X	X	X	X	X	X	X	X	X	X	X	X	X	X	X
5	103-487	Rear Blower Angle	X	X	X	X	X	X	X	X	X	X	X	X	X	X	X	X	X	X	X	X	X	X
7	8401-036	Contactor 2-Pole 30A		X	2		X	2	3		X	2	2		X	X	2	3	4		X	2	3	4
8	142-159	Heater Blank Off Plate	X	X	X	X	X			X	X	X		X	X	X	X			X	X	X		
	8604-135	Heat Strip 5KW							X				X					X					X	
	8604-136	Heat Strip 10KW																X						X
9	8201-130	Relay		X	X		X	X		X	X	X		X	X	X	X	X		X	X	X	X	X
10	142-159	Heater Blank Off Plate	X			X				X				X						X				
	8604-135	Heat Strip 5KW		X			X				X					X					X			
	8604-136	Heat Strip 10KW			X			X	X			X	X				X	X	X			X	X	X
	8604-134	Heat Strip 4KW													X	X								
11	3000-1402	6-Pin Electric Heater Wire Harness		X	X		X	X	X		X	X	X		X	X	X	X	X		X	X	X	X
12	127-418	Circuit Breaker Base	X	X	X	X	X	X	X	X	X	X	X	X	X	X	X	X	X	X	X	X	X	X
13	8615-037	Circuit Breaker 30A 2-Pole			X											X					X			
	8615-041	Circuit Breaker 60A 2-Pole						X	X			X	X				X	X	X			X	X	X
14	8615-038	Circuit Breaker 35A 2-Pole	X																					
	8615-040	Circuit Breaker 50A 2-Pole		X	X									X		X								
	8615-055	Circuit Breaker 40A 2-Pole				X		X	X															
	8615-041	Circuit Breaker 60A 2-Pole					X				X				X				X	X	X	X	X	X
	8615-039	Circuit Breaker 45A 2-Pole								X		X	X					X	X					

NS = Not Shown

ELECTRIC HEATER COMPONENTS

Drawing No.	Part Number	Description	130H1-B0Z, 130H1DB0Z	130H1-B06, 130H1DB06	130H1-B09, 130H1DB09	136H1-B0Z, 136H1DB0Z	136H1-B06, 136H1DB06	136H1-B09, 136H1DB09	136H1-B15, 136H1DB15	142H1-B0Z, 142H1DB0Z	142H1-B06, 142H1DB06	142H1-B09, 142H1DB09	142H1-B15, 142H1DB15	148H1-B0Z, 148H1DB0Z	148H1-B06, 148H1DB06	148H1-B09, 148H1DB09	148H1-B15, 148H1DB15	148H1-B18, 148H1DB18	160H1-B0Z, 160H1DB0Z	160H1-B06, 160H1DB06	160H1-B09, 160H1DB09	160H1-B15, 160H1DB15	160H1-B18, 160H1DB18	
1	143-148	Heater Box Cover	X	X	X	X	X	X	X	X	X	X	X	X	X	X	X	X	X	X	X	X	X	X
2	117-313	Heater Front Plate	X	X	X	X	X	X	X	X	X	X	X	X	X	X	X	X	X	X	X	X	X	X
3	103-486	Side Blower Offset	2	2	2	2	2	2	2	2	2	2	2	2	2	2	2	2	2	2	2	2	2	2
4	117-307	Heater Wrapper	X	X	X	X	X	X	X	X	X	X	X	X	X	X	X	X	X	X	X	X	X	X
5	103-487	Rear Blower Angle	X	X	X	X	X	X	X	X	X	X	X	X	X	X	X	X	X	X	X	X	X	X
6	8607-014	Terminal Block																X					X	
7	8401-036	Contacto 2-Pole 30A		3	3		3	3	6		3	3	6		3	3	6	6		3	3	6	6	
8	142-159	Heater Blank Off Plate	X	X	X	X	X	X		X	X	X		X	X	X			X	X	X			
	8604-137	Heat Strip 6KW							X				X				X					X		
	8604-138	Heat Strip 9KW															X						X	
9	8201-130	Relay		X	X		X	X	X		X	X	X		X	X	X	X		X	X	X	X	
10	142-159	Heater Blank Off Plate	X			X				X				X					X					
	8604-137	Heat Strip 6KW		X			X				X				X					X				
	8604-138	Heat Strip 9KW			X			X	X			X	X			X	X	X			X	X	X	
11	3000-1402	6-Pin Electric Heater Wire Harness		X	X		X	X	X		X	X	X		X	X	X	X		X	X	X	X	
12	127-418	Circuit Breaker Base	X	X	X		X	X	X	X	X	X	X	X	X	X	X	X	X	X	X	X	X	
13	8615-046	Circuit Breaker 60A 3-Pole							X				X				X					X	X	
14	8615-051	Circuit Breaker 25A 3-Pole	X																					
	8615-042	Circuit Breaker 35A 3-Pole		X						X				X										
	8615-052	Circuit Breaker 30A 3-Pole				X																		
	8615-044	Circuit Breaker 45A 3-Pole			X		X		X				X				X		X			X	X	
	8615-045	Circuit Breaker 50A 3-Pole						X			X				X									
	8615-046	Circuit Breaker 60A 3-Pole										X				X		X		X	X			

NS = Not Shown

ELECTRIC HEATER COMPONENTS

Drawing No.	Part Number	Description	130H1-C0Z, 130H1DC0Z	130H1-C06, 130H1DC06	130H1-C09, 130H1DC09	136H1-C0Z, 136H1DC0Z	136H1-C06, 136H1DC06	136H1-C09, 136H1DC09	136H1-C15, 136H1DC15	136H1DC15NPD114	142H1-C0Z, 142H1DC0Z	142H1-C06, 142H1DC06	142H1-C09, 142H1DC09	142H1-C15, 142H1DC15	148H1-C0Z, 148H1DC0Z	148H1-C06, 148H1DC06	148H1-C09, 148H1DC09	148H1-C15, 148H1DC15	148H1-C18, 148H1DC18	160H1-C0Z, 160H1DC0Z	160H1-C06, 160H1DC06	160H1-C09, 160H1DC09	160H1-C15, 160H1DC15	160H1-C18, 160H1DC18	
1	143-148	Heater Box Cover	X	X	X	X	X	X	X	X	X	X	X	X	X	X	X	X	X	X	X	X	X	X	X
2	117-313	Heater Front Plate	X	X	X	X	X	X	X	X	X	X	X	X	X	X	X	X	X	X	X	X	X	X	X
3	103-486	Side Blower Offset	2	2	2	2	2	2	2	2	2	2	2	2	2	2	2	2	2	2	2	2	2	2	2
4	117-307	Heater Wrapper	X	X	X	X	X	X	X	X	X	X	X	X	X	X	X	X	X	X	X	X	X	X	X
5	103-487	Rear Blower Angle	X	X	X	X	X	X	X	X	X	X	X	X	X	X	X	X	X	X	X	X	X	X	X
6	8607-014	Terminal Block						X	X					X				X						X	
7	8401-036	Contactora 2-Pole 30A		2	2		2	2	6	6		2	2	6		2	2	6	4		2	2	6	4	
8	142-159	Heater Blank Off Plate	X	X	X	X	X				X	X	X		X	X	X			X	X	X			
	8604-139	Heat Strip 6KW							X	X				X				X						X	
	8604-140	Heat Strip 9KW																	X						X
9	8201-130	Relay		X	X		X	X	X	X		X	X	X		X	X	X	X		X	X	X	X	X
10	142-159	Heater Blank Off Plate	X			X					X				X					X					
	8604-139	Heat Strip 6KW		X			X					X				X					X				
	8604-140	Heat Strip 9KW			X			X	X	X			X	X			X	X	X				X	X	X
11	3000-1402	6-Pin Electric Heater Wire Harness		X	X		X	X	X	X		X	X	X		X	X	X	X		X	X	X	X	X
12	127-418	Circuit Breaker Base	X	X	X	X	X	X	X	X	X	X	X	X	X	X	X	X	X	X	X	X	X	X	X
15	8615-067	Toggle Disconnect 40A 460V	X	X	X	X	X	X			X	X	X	X	X	X	X	X	X	X	X	X	X	X	X
15	8615-077	Circuit Breaker, 30A, 3-Pole, 460V							X																
NS	8615-069	Toggle Disconnect Cover Plate	X	X	X	X	X	X			X	X	X	X	X	X	X	X	X	X	X	X	X	X	X

NS = Not Shown

VENT BOX (ONLY) COMPONENTS

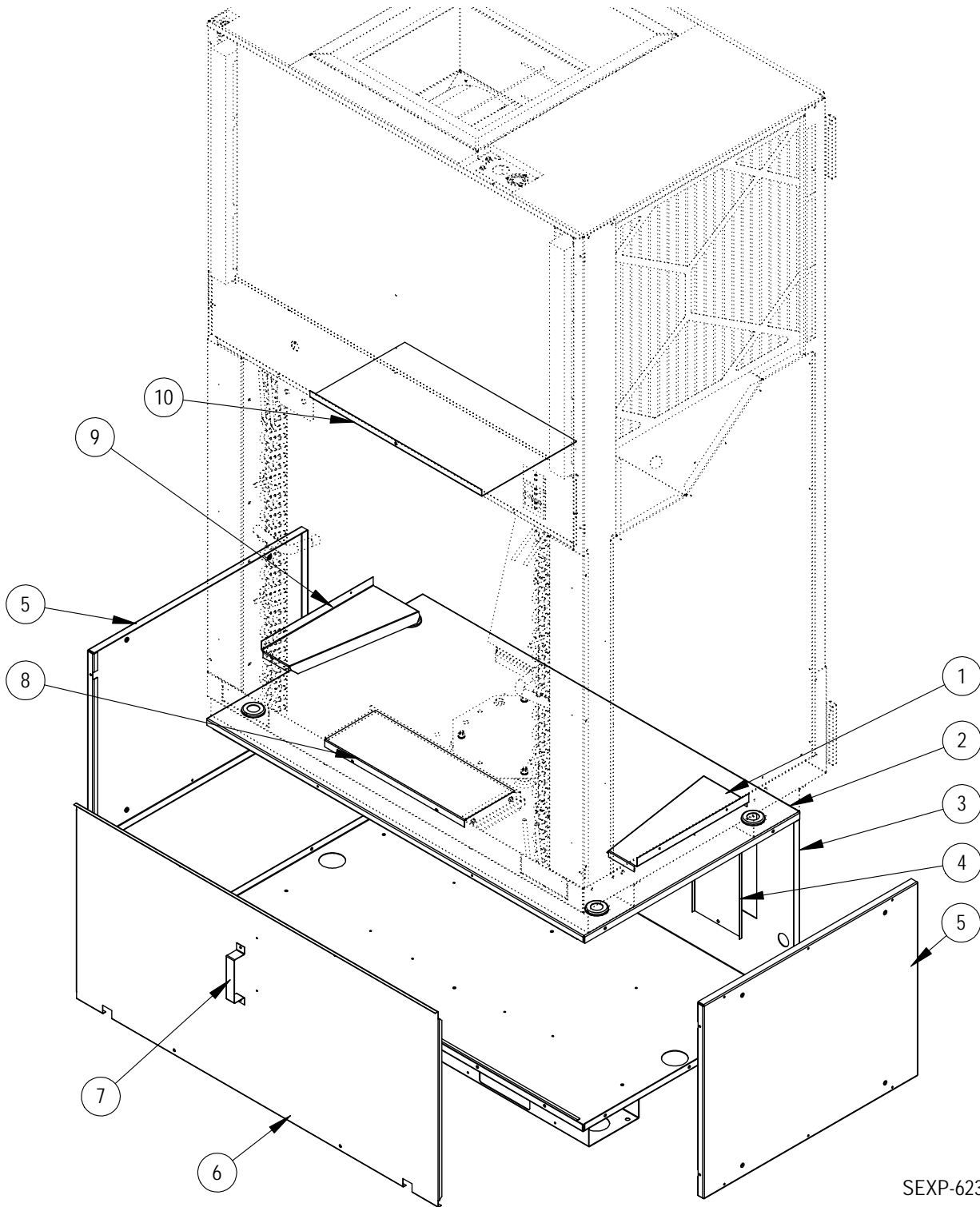

SEXP-623

VENT BOX (ONLY) COMPONENTS

Drawing No.	Part Number	Description	Vent Box Only
1	S143X164	Right Side Intake Fill	X
2	507-298	Vent Box Top	X
3	S527-419	Vent Box Base	X
4	543-158	Drain Access Plate	2
5	S501-639	Vent Box Side	2
6	553-508	Vent Box Door	X
7	113-441	Door Latch Bracket	X
8	S143-160	Lower Intake Fill	X
9	S143Y164	Left Side Intake Fill	X
10	S143-161	Upper Intake Fill	X

CRV COMPONENTS

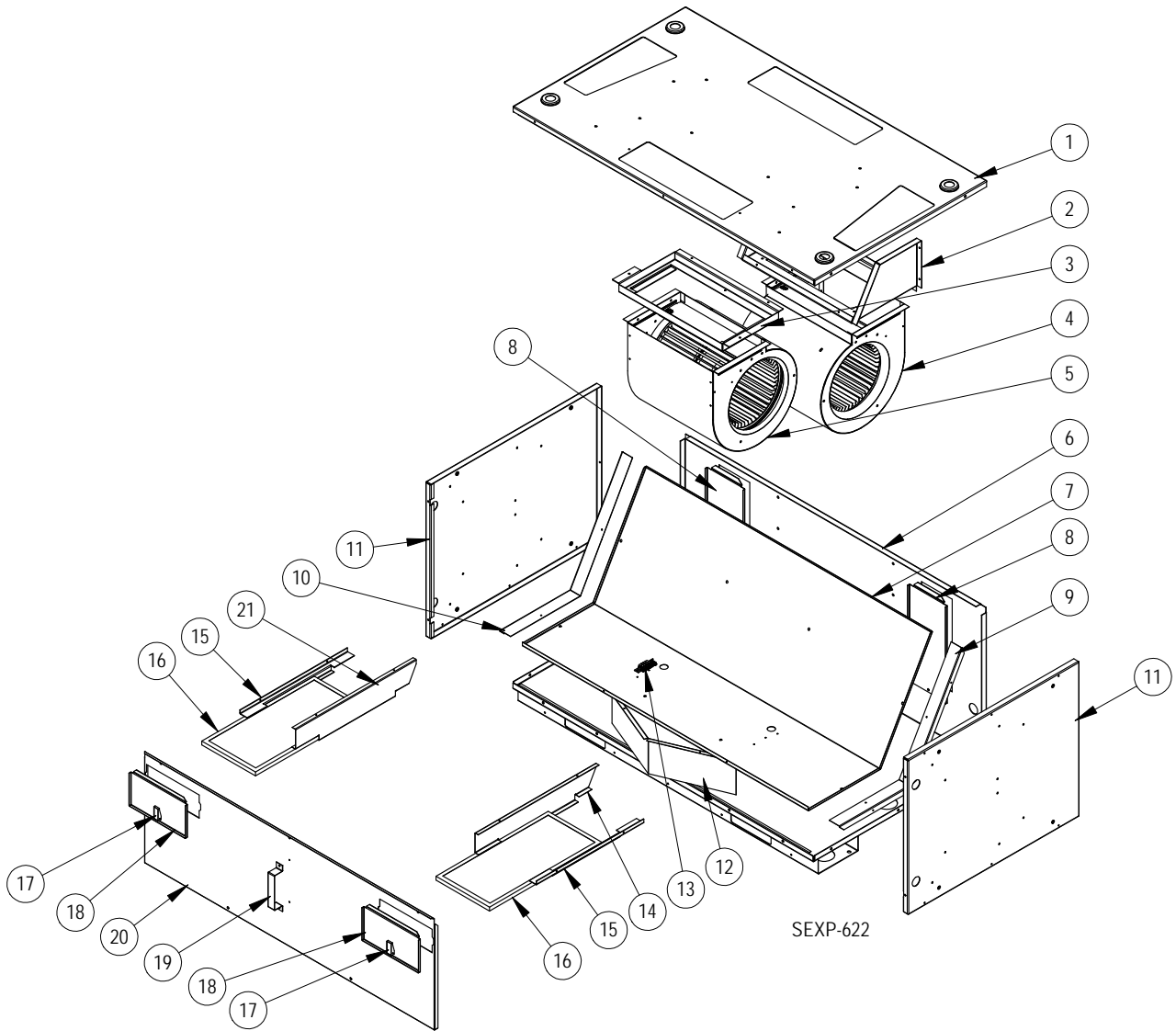

CRV COMPONENTS

Drawing No.	Part Number	Description	CRV 920-0012		ERV/ECON 920-0196	
1	S507-297	Vent Box Top	X	X		
2	103-489	Rear Blower Offset	X	X		
3	103-488	Front Blower Offset	X	X		
4	900-318-001	Exhaust Blower Assembly	X			
4	900-318-005	Exhaust Blower Assembly				X
5	900-318-002	Intake Blower Assembly	X			
5	900-316-006	Intake Blower Assembly				X
6	S527-419	Vent Box Base	X	X		
7	521-459	Partition	X	X		
8	543-158	Drain Access Plate	2	2		
9	505X1260	Right Partition Angle	X	X		
10	505Y1260	Left Partition Angle	X	X		
11	S501-638	Vent Box Side	2	2		
12	569-179	Baffle	X	X		
13	S910-1809	Terminal Block Assembly	X	X		
14	141X382	Right Lower Filter Bracket	X	X		
15	141-381	Filter Angle	2	X		
16	7003-064	Vent Intake Filter	2	2		
17	1171-053	Swell Latch	2	2		
18	S153-506	Filter Door	2	2		
19	113-441	Door Latch Bracket	X	X		
20	S553-507	Blower Door	X	X		
21	141Y382	Left Lower Filter Bracket	X	X		
NS	3000-1403	Intake/Exhaust Power Plug	X	X		
NS	3000-1404	Intake/Exhaust Speed Plug	2			
NS	3000-1445	Intake/Exhaust Speed Plug				X
NS	3000-1406	Vent Section Plug	X			
NS	3000-1446	Vent Section Plug				X
NS	3000-1411	Unit Control Panel Plug	X			
NS	3000-1447	Unit Control Panel Plug				X
NS	8201-062	Relay (in unit Control Panel)	X			
NS	8201-130	Relay, SPDT				3
NS	8201-071	Relay, 3PDT				1

NS = Not Shown

MODULATING CRV COMPONENTS

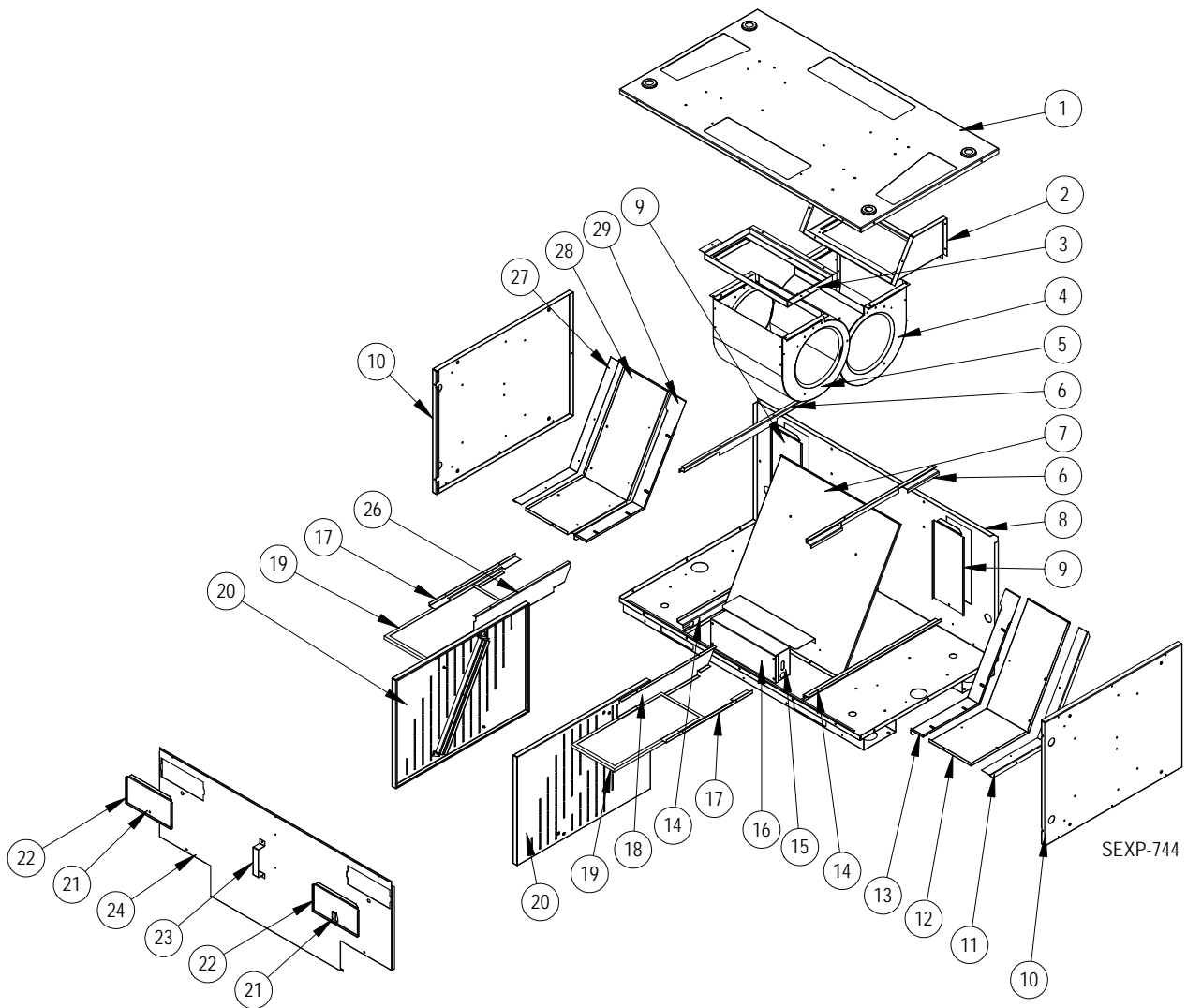

MODULATING CRV COMPONENTS

Drawing No.	Part Number	Description	Modulating CRV
1	S507-297	Vent Box Top	X
2	103-489	Rear Blower Offset	X
3	103-488	Front Blower Offset	X
4	900-319-001	Exhaust Blower Assembly	X
5	900-319-002	Intake Blower Assembly	X
6	141-379	Cassette Upper Rail	2
7	521-457	Partition	X
8	S527-419	Vent Box Base	X
9	543-158	Drain Access Plate	2
10	S501-638	Vent Box Side	2
11	505X1260	Right Partition Angle	X
12	521-464	Right Side Partition	X
13	S105X1258	Right Cassette Seal Angle	X
14	141-380	Cassette Lower Rail	2
15	Control Panel	See Control Panel section	x
16	153-511	Control Panel Cover	X
17	141-381	Filter Angle	2
18	141X382	Right Lower Filter Bracket	X
19	7003-064	Vent Intake Filter	2
20	139-332	Restrictor Plate	2
21	1171-053	Swell Latch	2
22	S153-506	Filter Door	2
23	113-441	Door Latch Bracket	X
24	S553-505	Cassette Door	X
26	141Y382	Left Lower Filter Bracket	X
27	105Y1260	Left Partition Angle	X
28	521-465	Left Side Partition	X
29	S105Y1258	Left Cassette Seal Angle	X

MODULATING CRV CONTROL PANEL COMPONENTS

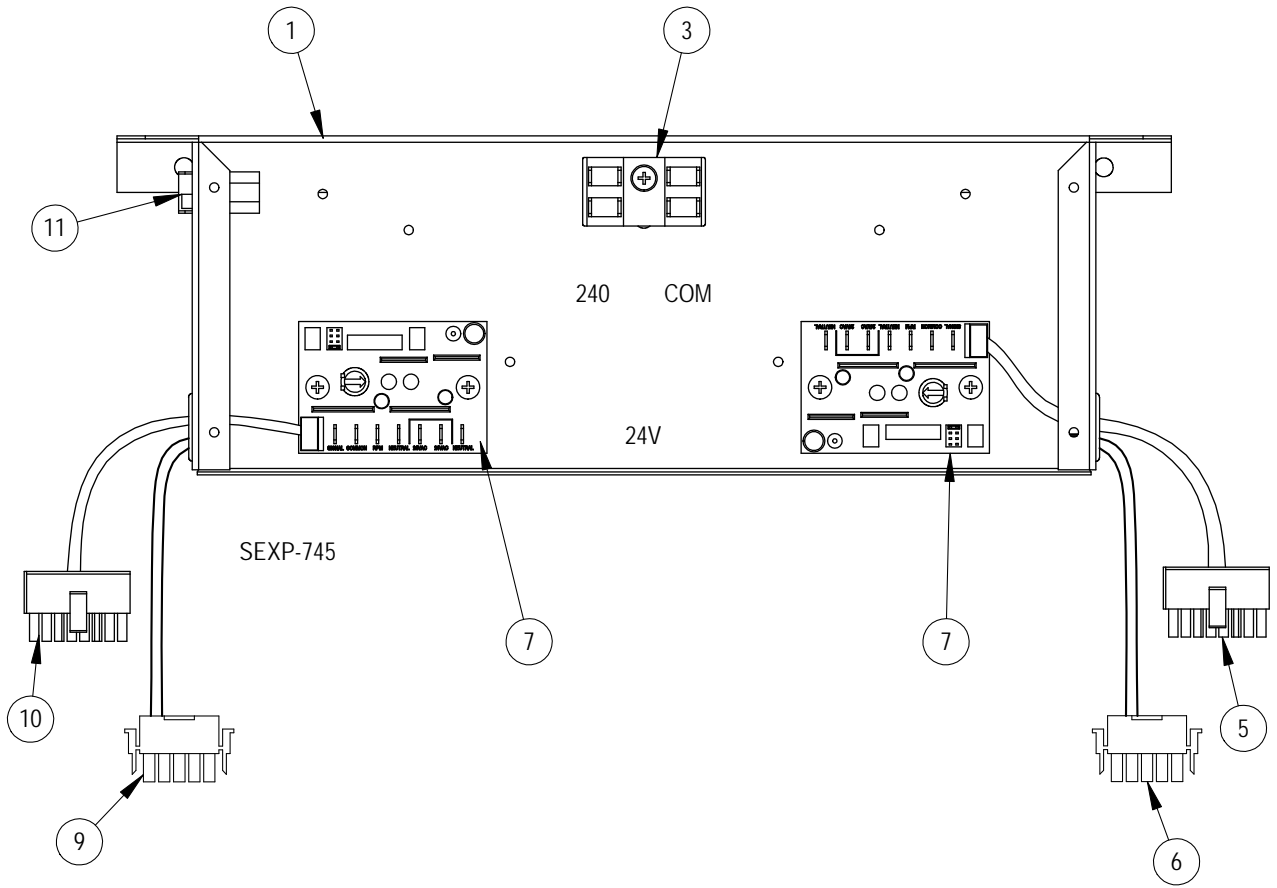

MODULATING CRV CONTROL PANEL COMPONENTS

Drawing No.	Part Number	Description	Modulating CRV Control Panel
1	117-323	Control Panel	X
3	8607-017	Terminal Block	X
5	3000-1407	Exhaust Speed Plug	X
6	3000-1331	Intake Plover Plug	X
7	8201-124	Blower Control Board	2
9	3000-1356	Intake Speed Plug	X
10	3000-1358	Exhaust Power Plug	X
11	3000-1409	Vent Section Plug	X
NS	3000-1408	Extension Plug	X
NS	3000-1405	Unit Control Panel Plug	X
NS	8201-013	Relay (in unit Control Panel)	X

NS = Not Shown

ERV COMPONENTS

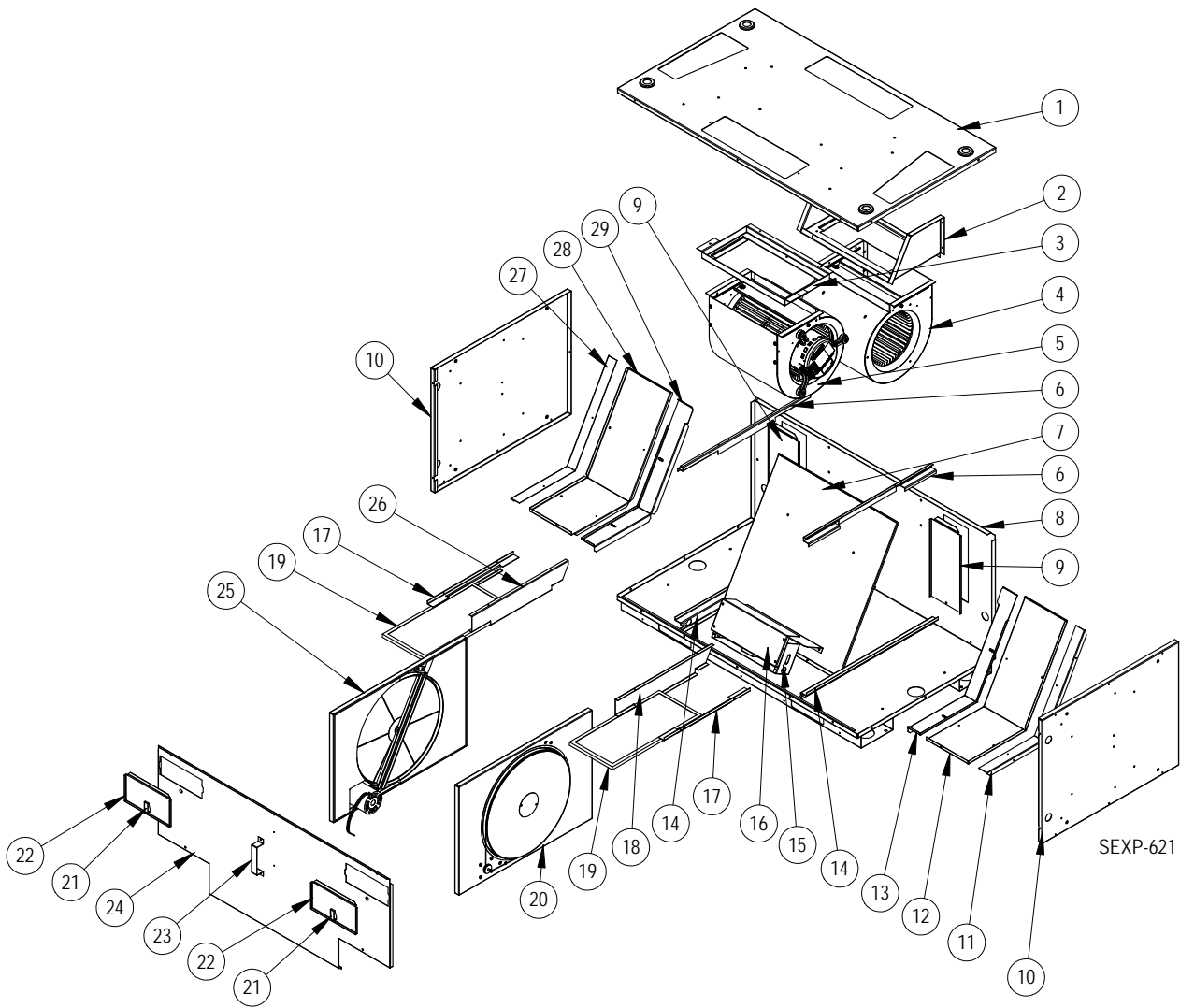

ERV COMPONENTS

Drawing No.	Part Number	Description	ERV
1	S507-297	Vent Box Top	X
2	103-489	Rear Blower Offset	X
3	103-488	Front Blower Offset	X
4	900-319-001	Exhaust Blower Assembly	X
5	900-319-002	Intake Blower Assembly	X
6	141-379	Cassette Upper Rail	2
7	521-457	Partition	X
8	S527-419	Vent Box Base	X
9	543-158	Drain Access Plate	2
10	S501-638	Vent Box Side	2
11	505X1260	Right Partition Angle	X
12	521-464	Right Side Partition	X
13	S105X1258	Right Cassette Seal Angle	X
14	141-380	Cassette Lower Rail	2
15	Control Panel	See Control Panel section	x
16	153-511	Control Panel Cover	X
17	141-381	Filter Angle	2
18	141X382	Right Lower Filter Bracket	X
19	7003-064	Vent Intake Filter	2
20	5070-055	Right Cassette Assembly - Complete See cassette section for individual parts	X
21	1171-053	Swell Latch	2
22	S153-506	Filter Door	2
23	113-441	Door Latch Bracket	X
24	S553-505	Cassette Door	X
25	5070-056	Left Cassette Assembly - Complete See cassette section for individual parts	X
26	141Y382	Left Lower Filter Bracket	X
27	105Y1260	Left Partition Angle	X
28	521-465	Left Side Partition	X
29	S105Y1258	Left Cassette Seal Angle	X

ERV CONTROL PANEL COMPONENTS

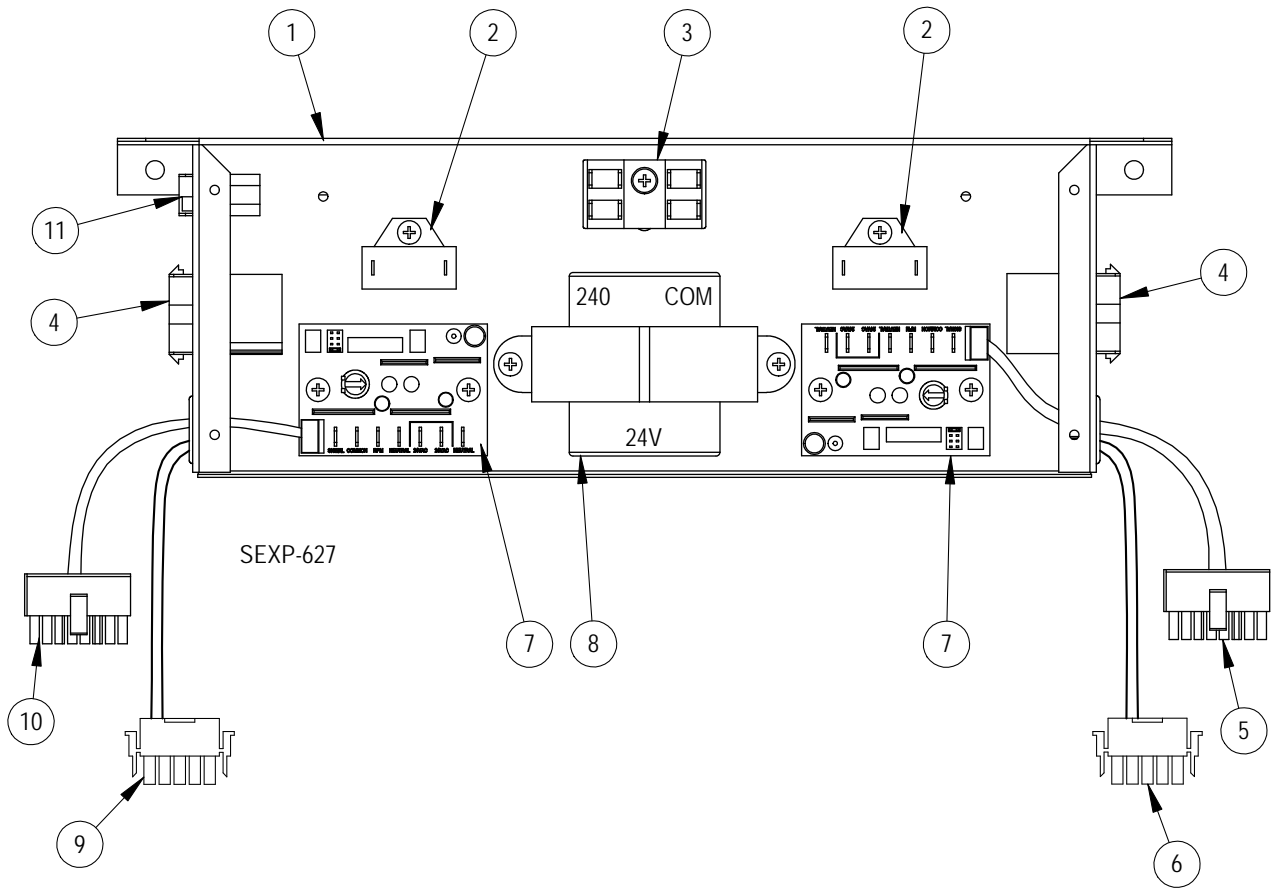

ERV CONTROL PANEL COMPONENTS

Drawing No.	Part Number	Description	ERV Control Panel
1	117-323	Control Panel	X
2	8552-070	3MFD 250V Capacitor	2
3	8607-017	Terminal Block	X
4	3000-1410	Cassette Motor Plug	2
5	3000-1407	Exhaust Speed Plug	X
6	3000-1331	Intake Plover Plug	X
7	8201-124	Blower Control Board	2
8	8407-043	60VA Transformer	X
9	3000-1356	Intake Speed Plug	X
10	3000-1358	Exhaust Power Plug	X
11	3000-1409	Vent Section Plug	X
NS	3000-1408	Extension Plug	X
NS	3000-1405	Unit Control Panel Plug	X
NS	8201-013	Relay (in unit Control Panel)	X

NS = Not Shown

ERV CASSETTE COMPONENTS

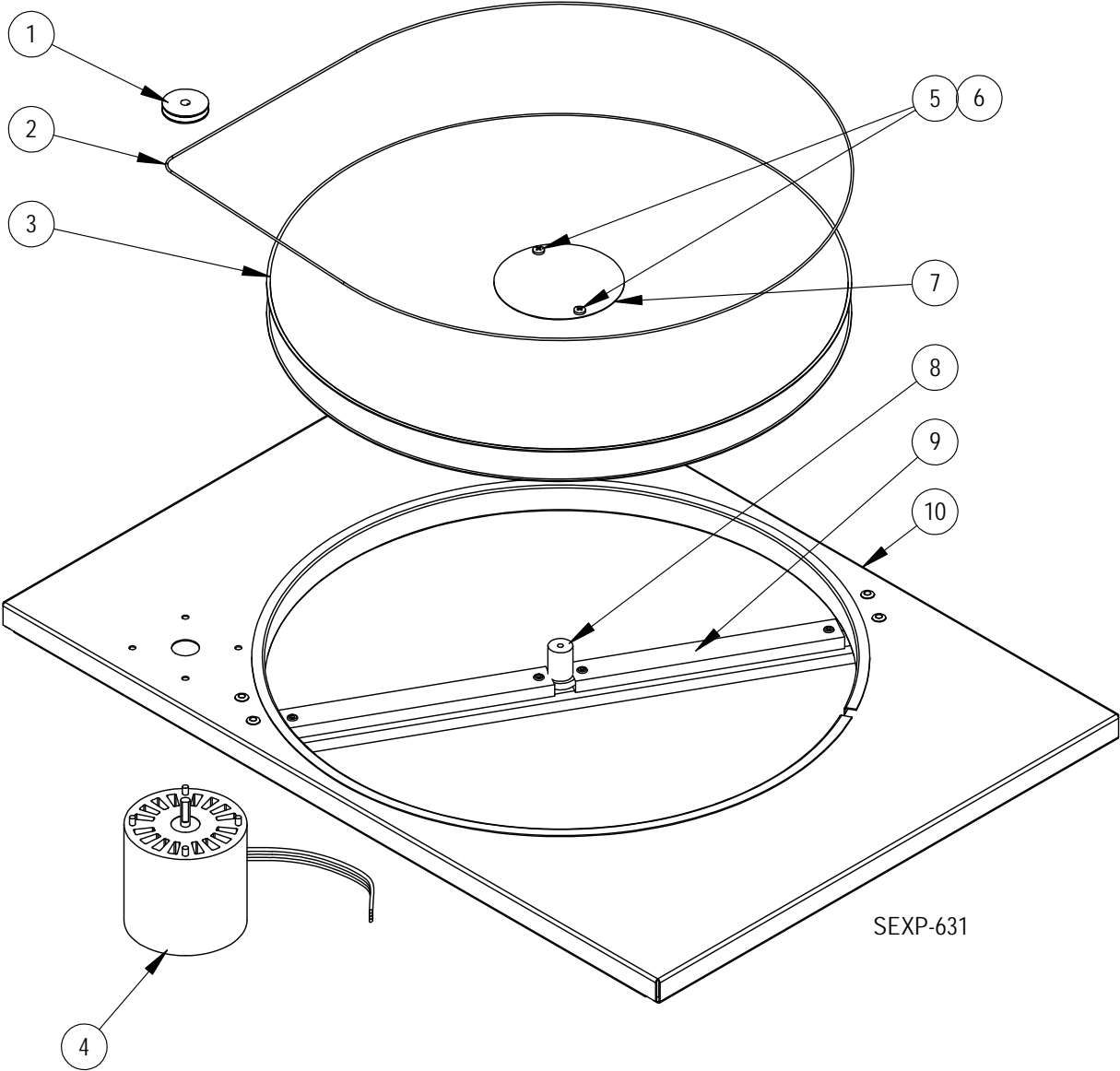

ERV CASSETTE COMPONENTS

Drawing No.	Part Number	Description	5070-055 Right Cassette	5070-056 Left Cassette
1	5501-018	Pulley	X	X
2	5070-054	Drive Belt	X	X
3	5070-043	Cassette Wheel	X	X
4	8101-016	Motor	X	X
5	1012-164	Machine Screw	2	2
6	8611-111	Nylon Spacer	2	2
7	142-104	Hub Cover	X	X
8	1912-012	Wheel Shaft	X	X
9	105-1259	Cassette Wheel Angle	X	X
10	539X275	Right Hand Cassette Plate	X	
10	539Y275	Left Hand Cassette Plate		X
NS	8620-204	ERV Bearing, Shaft & Hardware Kit	X	X
NS	8620-205	ERV Shaft & Hardware Kit	X	X

NS = Not Shown

CRV/ERV BLOWER COMPONENTS

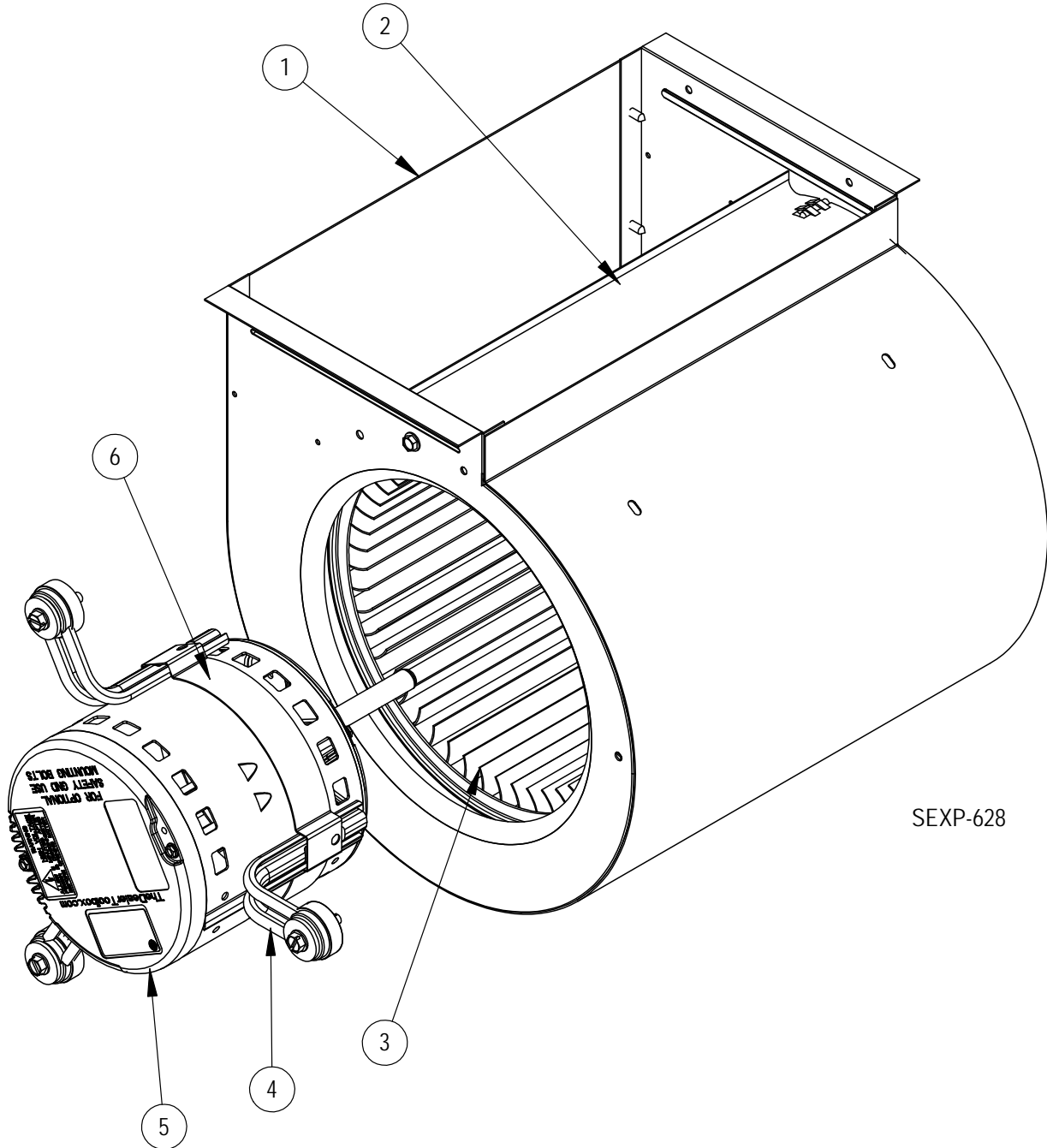

CRV/ERV BLOWER COMPONENTS

Drawing No.	Part Number	Description	900-318-001	900-318-002	900-319-001	900-319-002
1	151-124	Blower Housing	X	X	X	X
2	144-129	Diffuser	X	X	X	X
3	5152-067	Blower Wheel	X	X	X	X
4	8200-046	Motor Mount Arm	3	3	3	3
5	S8105-056-0104	1/3 HP Programmed Motor – CRV Exhaust	X			
	S8105-056-0105	1/3 HP Programmed Motor – CRV Intake		X		
	S8105-059-0106	1/3 HP Programmed Motor – ERV Exhaust			X	
	S8105-059-0107	1/3 HP Programmed Motor – ERV Intake				X
6	8620-034	Motor Mount Band	X	X	X	X

SLEEVE COMPONENTS

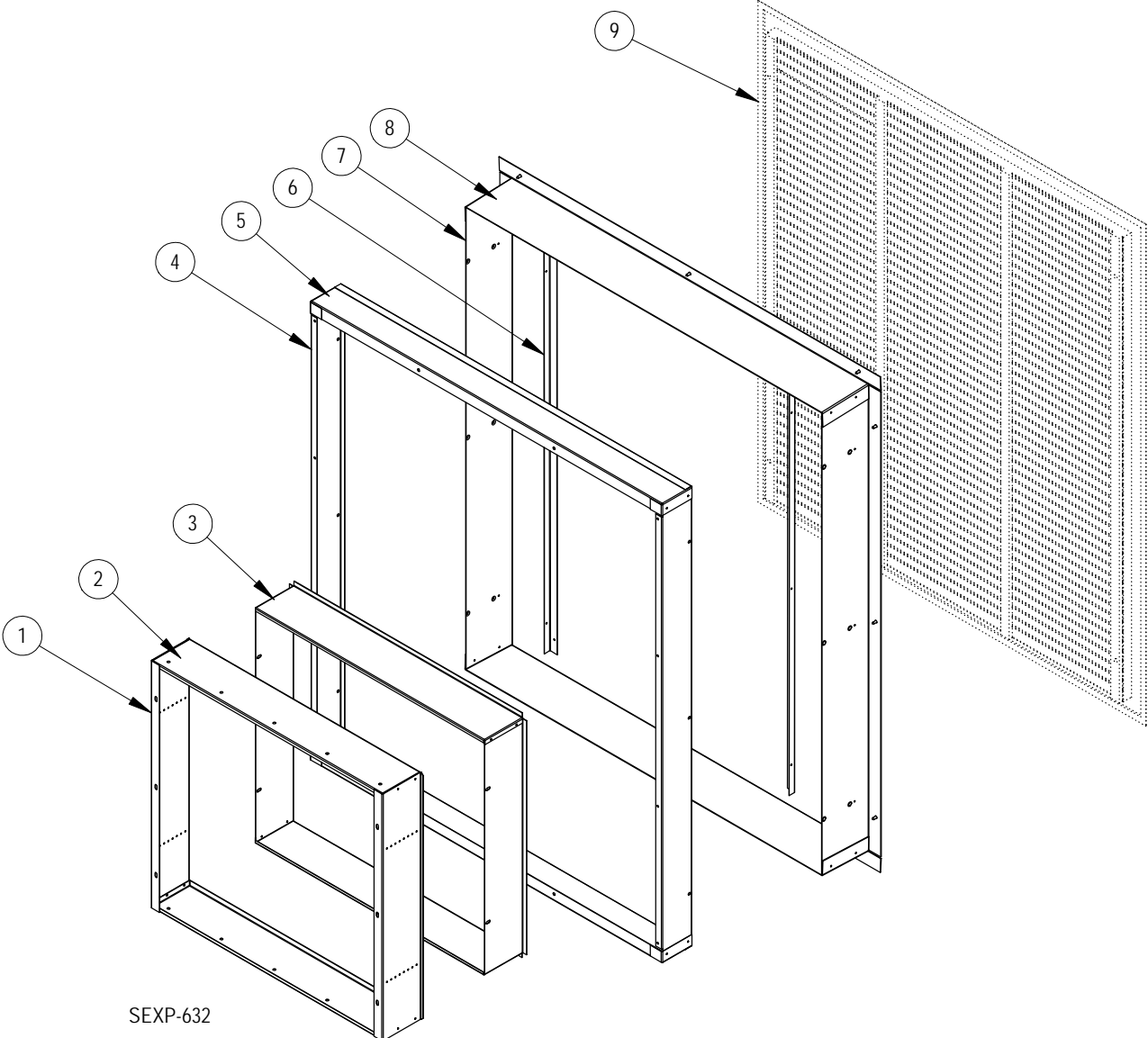

SEXP-632

SLEEVE COMPONENTS

Drawing No.	Part Number	Description	IWS-A	IWS-B	IWS-C
1	S111-188-8 4½" Deep	Outer Sleeve Side	2		
	S111-195-8 7" Deep			2	
	S111-202-8 12" Deep				2
2	S111-187-8 4½" Deep	Outer Sleeve End	2		
	S111-194-8 7" Deep			2	
	S111-201-8 12" Deep				2
3	111-189-8 4½" Deep	Inner Fan Sleeve Side	2		
	111-196-8 7" Deep			2	
	111-203-8 12" Deep				2
4	111-186-8 3½" Deep	Inner Sleeve Side	2		
	111-193-8 6" Deep			2	
	111-200-8 11" Deep				2
5	111-185-8 3½" Deep	Inner Sleeve End	2		
	111-192-8 6" Deep			2	
	111-199-8 11" Deep				2
6	105-1257-8	Grille Support Angle	2	2	2
7	111-184-8 5½" Deep	Outer Sleeve Side	2		
	111-191-8 8" Deep			2	
	111-198-8 13" Deep				2
8	111-183-8 5½" Deep	Outer Sleeve End	2		
	111-190-8 8" Deep			2	
	111-197-8 13" Deep				2
9	ILG-10	Outdoor Louver Grille - Clear anodized	X	X	X
	ILG-20	Outdoor Louver Grille - Medium Bronze	X	X	X
	ILG-30	Outdoor Louver Grille - Dark Bronze	X	X	X

RISER PLATFORM COMPONENTS

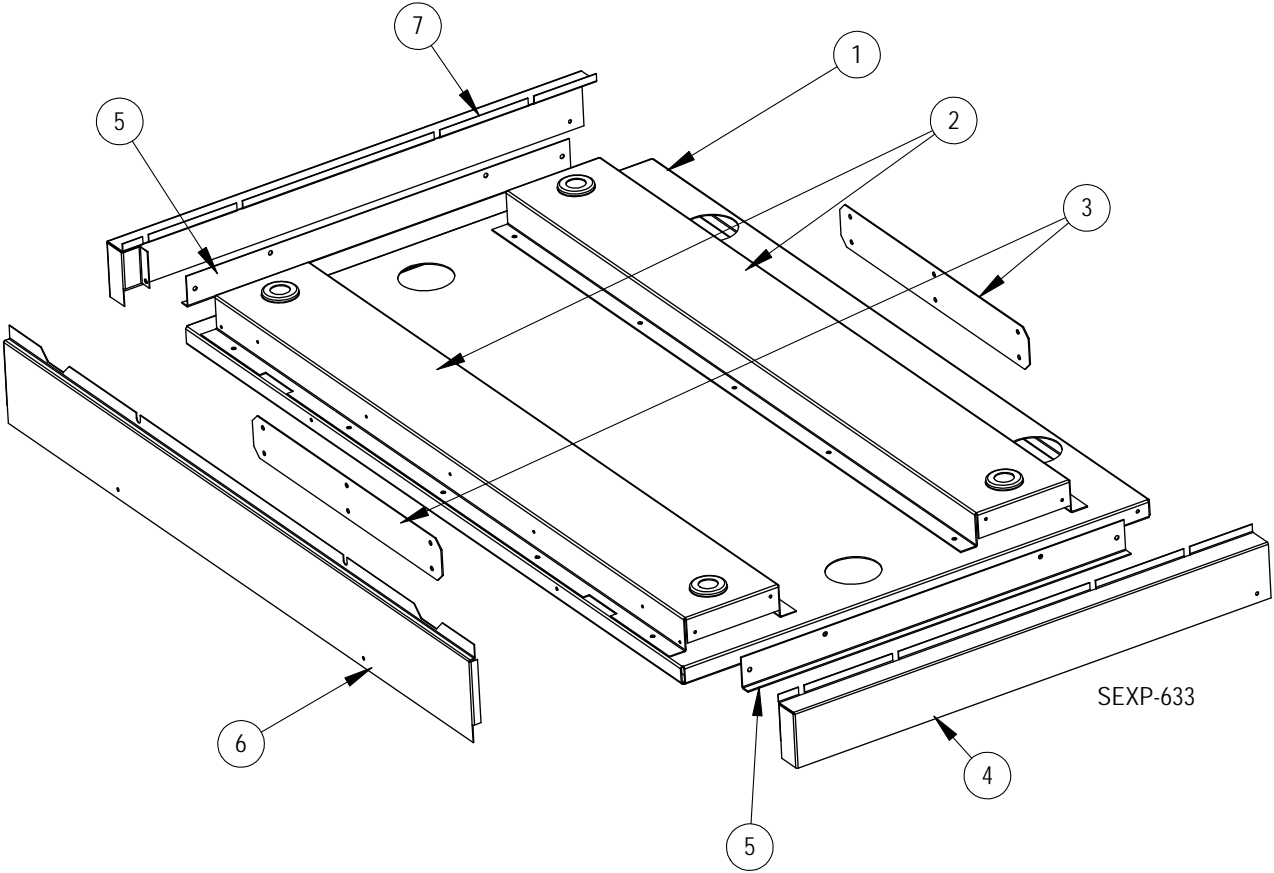

RISER PLATFORM COMPONENTS

Drawing No.	Part Number	Description	IRP-3*	IRP-6*
1	127-420-X	Base Plate	X	X
2	141-384 3" 141-385 6"	Base Rail	2	2
3	112-447	Base Connection Plate	2	2
4	135-311-* 3" 135-314-* 6"	Right Side Trim	X	X
5	105-1263 3" 105-1264 6"	Side Support Angle	2	2
6	135-309-* 3" 135-312-* 6"	Front Trim	X	X
7	135-310-* 3" 135-313-* 6"	Left Side Trim	X	X

* Exterior cabinet parts are manufactured with various paint color options. To ensure the proper paint color is received, reference the following codes:

Beige -X
White -1
Buckeye Gray -4