REPLACEMENT PARTS MANUAL

WALL MOUNTED PACKAGE HEAT PUMPS

Models: **T30S1**
T30S1D

General Notes

- Revised and/or additional pages may be issued from time to time.
- A complete and current manual consists of pages shown in the following contents section.

Important

- Contact the installing and/or local Bard distributor for all parts requirements. Make sure you have the complete model and serial number available from the unit rating plates.

Contents

<i>Description</i>	<i>Page</i>
Cabinet Components	
♦ Exploded View	2
♦ Usage List	3
Functional Components	
♦ Exploded View	4
♦ Usage List	5, 6 & 7
Control Panel	
♦ Layout	8
♦ Usage List	9
Control Panel Components	
♦ Layout	10
♦ Usage List	11
Blower Assembly	
♦ Exploded View	12
♦ Usage List	12



Bard Manufacturing Company, Inc.
Bryan, Ohio 43506
Since 1914...Moving ahead, just as planned.

Manual: 2110-587D
Supersedes: 2110-587C
File: Tab 17
Date: 08-28-14

Climate Control Solutions

CABINET COMPONENTS

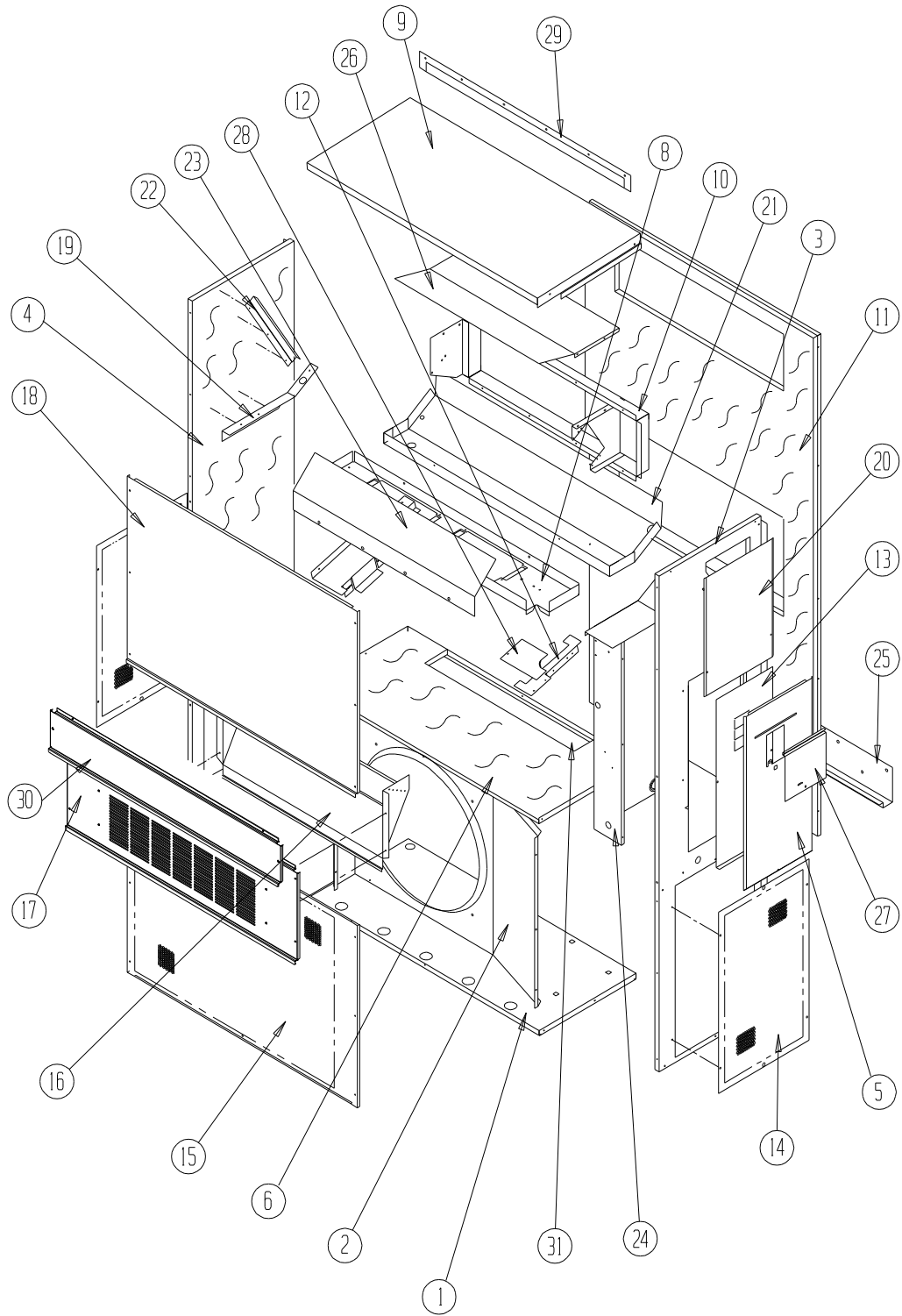

SEXP-514 A

CABINET COMPONENTS

Dwg. No.	Part Number	Description	T30S1-A, -B	T30S1-C	T30S1DA, DB	T30S1DC
1	S127-199	Lower Base	X	X	X	X
2	125-022	Fan Shroud	X	X	X	X
2	125-057 ③	Fan Shroud	X	X	X	X
3	S500-228-* ①	Right Side	X	X	X	X
3	S500-441-* ②	Right Side	X	X	X	X
3	S500-527-* ③	Right Side	X	X	X	X
4	S500-229-* ①	Left Side	X	X	X	X
4	S500-442-* ②	Left Side	X	X	X	X
4	S500-528-* ③	Left Side	X	X	X	X
5	S533-109-* ①	Control Panel Cover (Outer)	X	X	X	X
5	S533-182-* ②	Control Panel Cover (Outer)	X	X	X	X
5	S533-197-* ③	Control Panel Cover (Outer)	X	X	X	X
6	S521X384	Condenser Partition	X	X	X	X
8	121X182	Blower Partition	X	X	X	X
9	S506-277-* ①	Top	X	X	X	X
9	S506-245-* ②	Top	X	X	X	X
9	S506-275-* ③	Top	X	X	X	X
10	S111X030	Outlet Air Frame Assembly	X	X	X	X
11	S508-088	Back	X	X	X	X
11	S508-185 ②	Back	X	X	X	X
11	S508-222 ③	Back	X	X	X	X
12	113X195	Filter Bracket	2	2	2	2
13	S132-104	Control Panel Cover (Inner)	X		X	
13	S132-208	Control Panel Cover (Inner)		X		X
14	118-056-* ①	Side Grille	2	2	2	2
14	118-060-* ②	Side Grille	2	2	2	2
14	118-067-* ③	Side Grille	2	2	2	2
15	118-059-* ①	Condenser Grille	X	X	X	X
15	118-061-* ②	Condenser Grille	X	X	X	X
15	118-066-* ③	Condenser Grille	X	X	X	X
16	BFAD-3	Fresh Air Damper Assembly	X	X	X	X
17	S552-444-* ①	Service Door	X	X	X	X
17	S552-446-* ②	Service Door	X	X	X	X
17	S552-458-* ③	Service Door	X	X	X	X
18	S514-160-* ①	Upper Front	X	X	X	X
18	S514-161-* ②	Upper Front	X	X	X	X
18	S514-166-* ③	Upper Front	X	X	X	X
19	105X850	Left Side Support	X	X	X	X
20	S143-034-* ①	Right Side Cover Plate (Outer)	X	X	X	X
20	S143-103-* ②	Right Side Cover Plate (Outer)	X	X	X	X
20	S143-127-* ③	Right Side Cover Plate (Outer)	X	X	X	X
21	S123-127	Drain Pan	X	X	X	X
22	147-044	Left Evaporator Support	X	X	X	X
23	135-124	Air Baffle Shield	X	X	X	X
24	Control Panel Assembly	See Control Panel Assembly Drawing and Parts List Assembly	X	X	X	X
25	113-140	Bottom Mounting Bracket	X	X	X	X
26	135X123	Heat Shield	X	X	X	X
27	S153-218-* ①	Disconnect Access Door	X	X	X	X
27	S153-387-* ②	Disconnect Access Door	X	X	X	X
27	S153-405-* ③	Disconnect Access Door	X	X	X	X
28	137-259	Fill Plate	X	X	X	X
29	113-149-* ①	Top Rain Flashing	X	X	X	X
29	113-360-* ③	Top Rain Flashing	X	X	X	X
30	S552-444-* ①	Filter Door Assembly	X	X	X	X
30	S552-447-* ②	Filter Door Assembly	X	X	X	X
30	S553-459-* ③	Filter Door Assembly	X	X	X	X
31	S536-498-* ①	Condenser Part. Blank-Off Plate	X	X	X	X
NS	141-357	Compressor Mounting Plate	X	X	X	X

① Exterior cabinet parts are manufactured with various paint color options. To ensure that you receive the proper paint color, please reference the following codes:

Beige	-X	White	-1	Buckeye Gray	-4
Desert Brown	-5	Dark Bronze	-8		
② Aluminum	A	③ Stainless Steel	S	NS = Not Shown	

FUNCTIONAL COMPONENTS

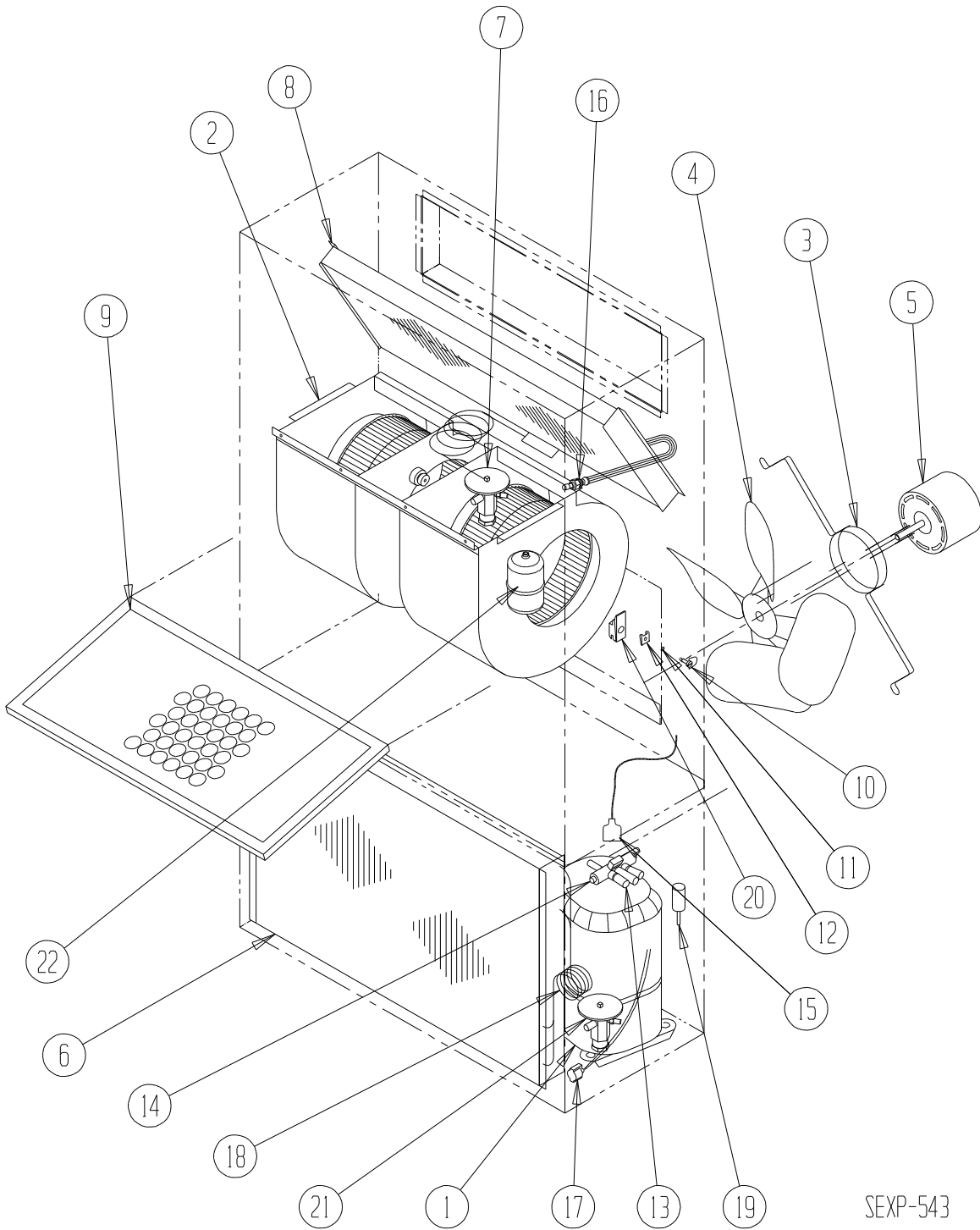

SEXP-543

FUNCTIONAL COMPONENTS

Dwg. No.	Part Number	Description	T30S1-A	T30S1-B	T30S1-C
1	8000-388	Compressor	X		
1	8000-389	Compressor		X	
1	8000-390	Compressor			X
2	S900-316-003	Blower Assembly	X	X	X
3	8200-001	Fan Motor Mount	X	X	X
4	5151-045	Fan Blade	X	X	X
5	8103-027	Condenser Motor	X	X	
5	8103-020	Condenser Motor			X
6	5051-112BX	Condenser Coil	X	X	X
7	5651-231	Cooling TXV	X	X	X
8	5060-163BX	Evaporator Coil	X	X	X
9	7004-019	Air Filter 1" Throw-Away	X	X	X
9	7004-048	Air Filter 2" Pleated MERV 11 ①	X	X	X
9	7004-030	Air Filter 2" Pleated MERV 8 ①	X	X	X
9	7004-026	Air Filter 2" Pleated MERV 6 ①	X	X	X
10	1171-022	1/4" Turn Fastener	X	X	X
11	1171-024	1/4" Turn Retainer	X	X	X
12	1171-023	1/4" Receptacle	X	X	X
13	5650-039	Reversing Valve with 24V Solenoid Coil	X	X	X
14	5650-042	Rev. Valve Solenoid, Red Casing (Ranco)	X	X	X
14	5650-043	Rev. Valve Solenoid, Black Casing (Wilspec)	X	X	X
14	5650-046	Rev. Valve Solenoid, Black Casing (San Hua)	X	X	X
15	5650-037	Molded Plug 36" Lead	X	X	X
16	800-0392	Cooling Distributor Assembly w/Orifice	X	X	X
17	8620-224	Defrost Sensor	X	X	X
18	800-0403	Heating Distributor	X	X	X
19	1804-0385	High Pressure Switch (Flare) ①	X	X	X
21	5651-177	Heating TXV	X	X	X
22	5201-009	Filter Drier (Bi-Direct)	X	X	X
NS	1804-0107	Low Pressure Switch (Flare) ①	X	X	X
NS	8408-039	Dishcharge Line Thermostat	X	X	X
NS	CMH-20	Low Ambient Control (Flare) ①	X	X	X
NS	3000-1276	Molded Compressor Plug	X		
NS	3000-1223	Molded Compressor Plug Low Voltage	X	X	X
NS	8000-012	Sound Cover	X	X	X

NS – Not Shown

① – Optional

FUNCTIONAL COMPONENTS

Dwg. No.	Part Number	Description	T30S1DA	T30S1DB	T30S1DC
1	8000-388	Compressor	X		
1	8000-389	Compressor		X	
1	8000-390	Compressor			X
2	S900-316-003	Blower Assembly	X	X	X
3	8200-001	Fan Motor Mount	X	X	X
4	5151-045	Fan Blade	X	X	X
5	8103-027	Condenser Motor	X	X	
5	8103-020	Condenser Motor			X
6	5051-112BX	Condenser Coil	X	X	X
7	5651-177	Cooling TXV	X	X	X
8	917-0184BX	Evaporator Coil Assembly	X	X	X
9	7004-019	Air Filter 1" Throw-Away	X	X	X
9	7004-048	Air Filter 2" Pleated MERV 11 ①	X	X	X
9	7004-030	Air Filter 2" Pleated MERV 8 ①	X	X	X
9	7004-026	Air Filter 2" Pleated MERV 6 ①	X	X	X
10	1171-022	1/4" Turn Fastener	X	X	X
11	1171-024	1/4" Turn Retainer	X	X	X
12	1171-023	1/4" Receptacle	X	X	X
13	5650-039	Reversing Valve with 24V Solenoid Coil	X	X	X
14	5650-042	Rev. Valve Solenoid, Red Casing (Ranco)	X	X	X
14	5650-043	Rev. Valve Solenoid, Black Casing (Wilspec)	X	X	X
14	5650-046	Rev. Valve Solenoid, Black Casing (San Hua)	X	X	X
15	5650-037	Molded Plug 36" Lead	2	2	2
16	800-0392	Cooling Distributor	X	X	X
17	8620-224	Defrost Sensor	X	X	X
18	800-0403	Heating Distributor	X	X	X
19	1804-0385	High Pressure Switch (Flare) ①	X	X	X
21	5651-177	Heating TXV	X	X	X
22	5201-009	Filter Drier (Bi-Direct)	X	X	X
NS	1804-0107	Low Pressure Switch (Flare) ①	X	X	X
NS	8408-038	Freeze Stat	X	X	X
NS	8408-039	Discharge Line Thermostat	X	X	X
NS	CMH-20	Low Ambient Control (Flare) ①	X	X	X
NS	3000-1244	Molded Compressor Plug		X	X
NS	3000-1276	Molded Compressor Plug	X		
NS	5625-117	Flow Control (Orifice)	X	X	X
NS	5650-045	3-Way Valve with 24V Solenoid Coil	X	X	X
NS	3000-1223	Molded Compressor Plug Low Voltage	X	X	X
NS	8000-012	Sound Cover	X	X	X

NS – Not Shown

① – Optional

CONTROL PANEL

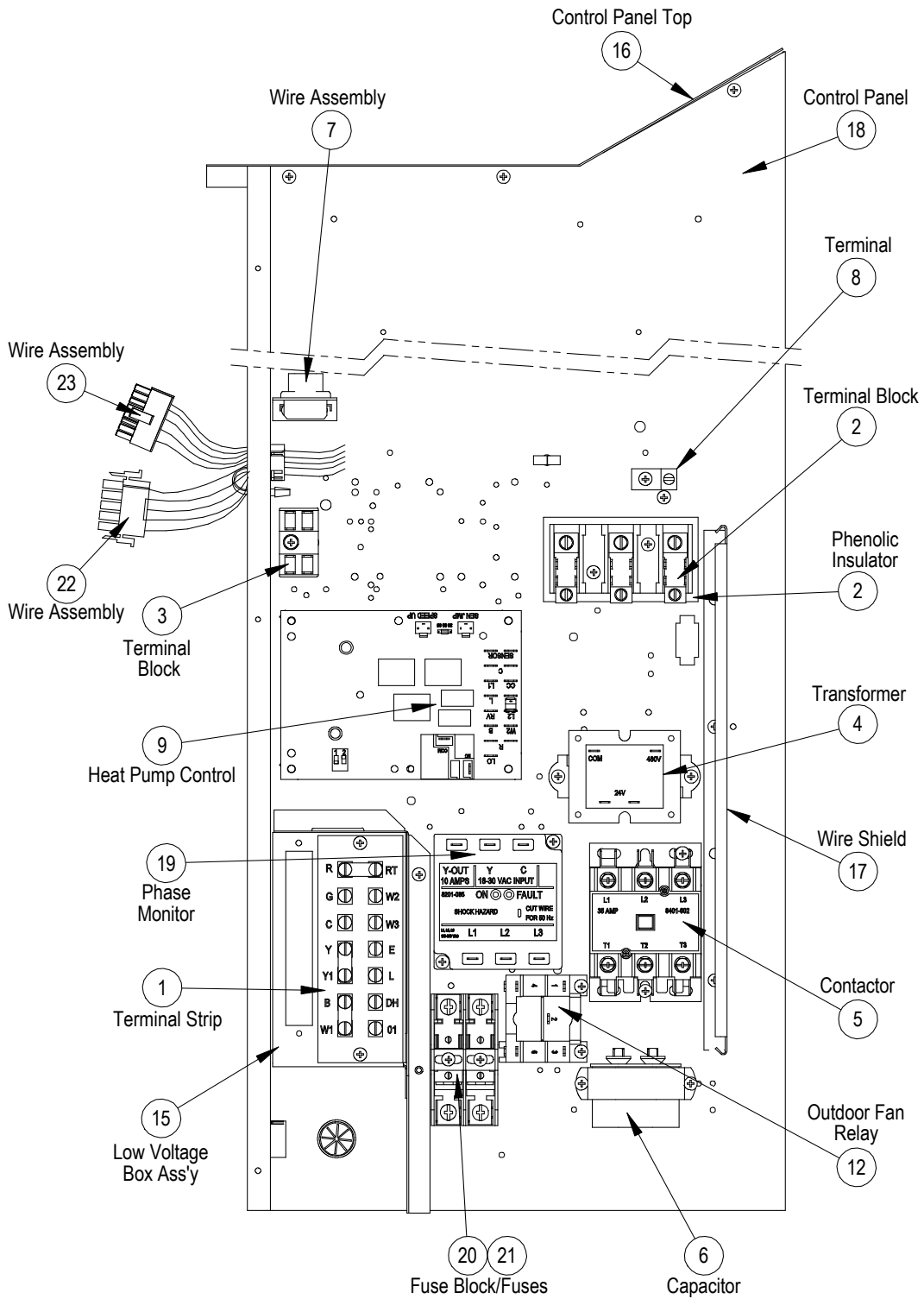

SEXP-603

CONTROL PANEL

Dwg. No.	Part Number	Description	T30S1-A	T30S1-B	T30S1-C
1	8607-031	Low Voltage Terminal Strip	X	X	X
2	8607-013	Terminal Block 2 Pole	X		
2	8607-014	Terminal Block 3 Pole		X	X
2	8607-015	Phenolic Insulator			X
3	8607-017	Terminal Block			X
4	8407-035	Transformer	X	X	
4	8407-042	Transformer			X
5	8401-006	Compressor Contactor	X		
5	8401-002	Compressor Contactor		X	X
6	8552-050	Compressor Capacitor	X		
6	8552-002	Outdoor Motor Capacitor		X	X
7	3000-1379	6 Pin Connector	X	X	X
8	8611-006	Ground Terminal	X	X	X
9	8620-223	Heat Pump Control Board w/LPB	X	X	X
12	8201-032	Outdoor Fan Relay			X
15	S117X138	Low Voltage Box	X	X	X
16	117X137	Control Panel Top	X	X	X
17	135-122	Wire Shield	X	X	X
18	117X123	Control Panel	X	X	X
19	8201-126	Phase Monitor		X	X
20	8614-041	Fuse Block			X
21	8614-046	Fuse			2
22	3000-1356	Blower Power Harness	X	X	X
23	3000-1378	Blower Control Harness	X	X	X
NS	8551-004	Start Device ① (PTCR)	X		
NS	8201-086	LAC Bypass Relay ①	X	X	X
NS	4096-154	Wiring Diagram	X		
NS	4096-254	Wiring Diagram		X	
NS	4096-355	Wiring Diagram			X
NS	8615-038	Circuit Breaker 35A 2 Pole (0Z)	X		
NS	8615-054	Circuit Breaker 20A 3 Pole (0Z)		X	
NS	8615-051	Circuit Breaker 25A 3 Pole (0Z)			X
NS	S8615-068	Rotary Disconnect (0Z)			X

① Optional on these models.

② Circuit breakers listed are for units without electric heat "0Z" models. Hot gas bypass models not available without electric heat. See Heater Replacement Parts Manual for units with electric heat.

NS = Not shown

CONTROL PANEL COMPONENTS

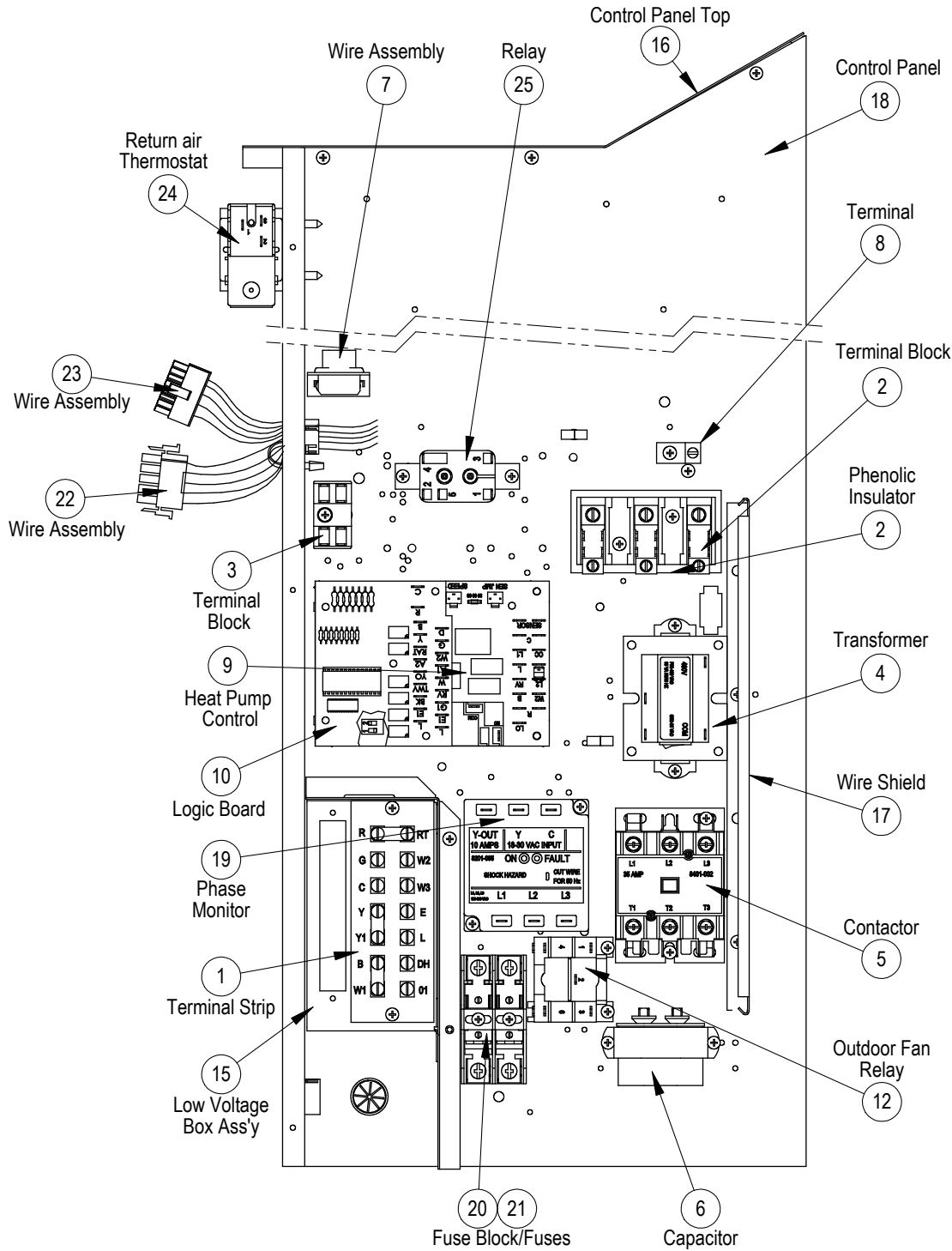

SEXP-635

CONTROL PANEL

Dwg. No.	Part Number	Description	T30S1DA	T30S1DB	T30S1DC
1	8607-031	Low Voltage Terminal Strip	X	X	X
2	8607-013	Terminal Block 2 Pole	X		
2	8607-014	Terminal Block 3 Pole		X	X
2	8607-015	Phenolic Insulator			X
3	8607-017	Terminal Block	X	X	X
4	8407-048	Transformer	X	X	
4	8407-050	Transformer			X
5	8401-006	Compressor Contactor	X		
5	8401-002	Compressor Contactor		X	X
6	8552-050	Compressor Capacitor	X		
6	8552-002	Outdoor Motor Capacitor		X	X
7	3000-1377	6 Pin Connector	X	X	X
8	8611-006	Ground Terminal	X	X	X
9	8620-223	Heat Pump Control Board w/LPB	X	X	X
10	8201-113	Dehumidification Logic Board	X	X	X
12	8201-032	Outdoor Fan Relay			X
15	S117X138	Low Voltage Box	X	X	X
16	117X137	Control Panel Top	X	X	X
17	135-122	Wire Shield	X	X	X
18	117X123	Control Panel	X	X	X
19	8201-126	Phase Monitor		X	X
20	8614-041	Fuse Block			X
21	8614-046	Fuse			2
22	3000-1356	Blower Power Harness	X	X	X
23	3000-1378	Blower Control Harness	X	X	X
24	8408-037	Return Air Thermostat	X	X	X
25	8201-062	Relay	X	X	X
NS	8551-004	Start Device ① (PTCR)	X		
NS	4096-155	Wiring Diagram	X		
NS	4096-255	Wiring Diagram		X	
NS	4096-356	Wiring Diagram			X
NS	8615-038	Circuit Breaker 35A 2 Pole (0Z)	X		
NS	8615-054	Circuit Breaker 20A 3 Pole (0Z)		X	
NS	8615-051	Circuit Breaker 25A 3 Pole (0Z)			X
NS	S8615-068	Rotary Disconnect (0Z)			X

① Optional on these models.

② Circuit breakers listed are for units without electric heat "0Z" models. Hot gas bypass models not available without electric heat. See Heater Replacement Parts Manual for units with electric heat.

NS = Not shown

BLOWER ASSEMBLY

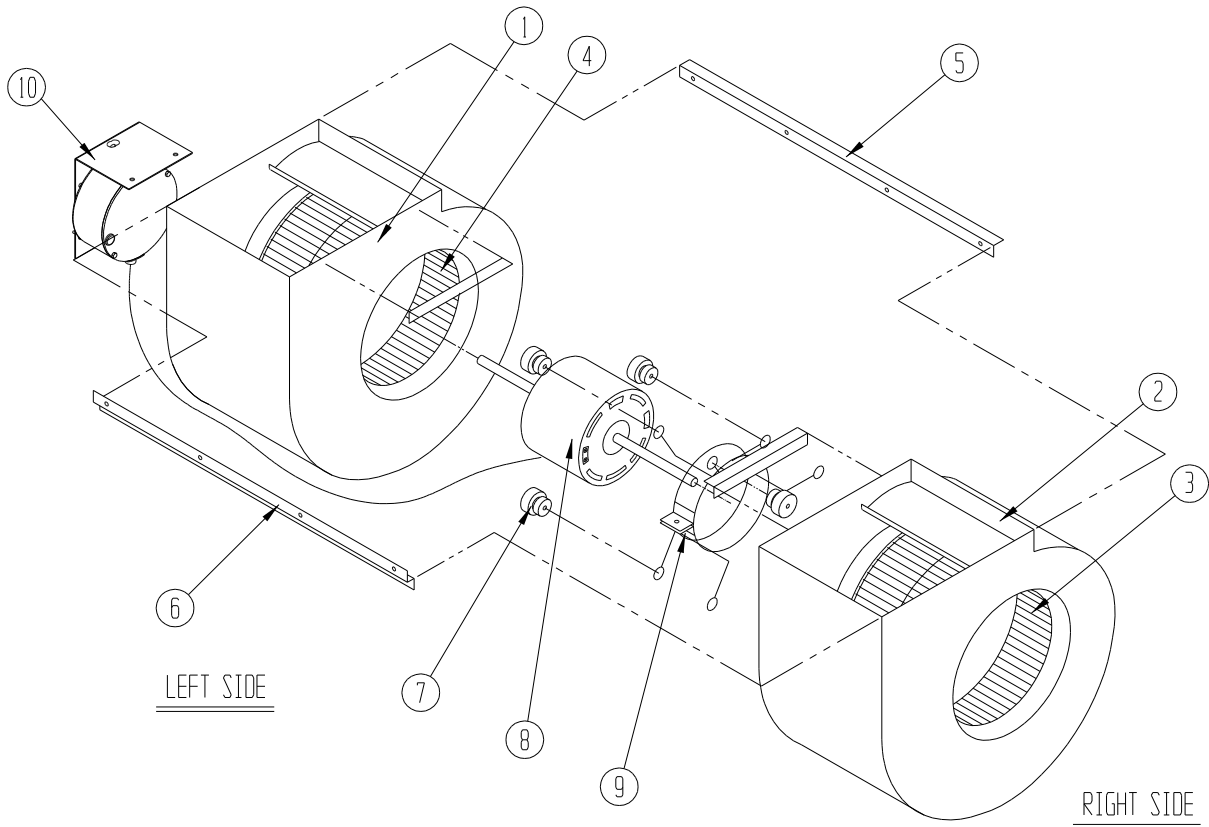

SEXP-602

Dwg. No.	Part Number	Description	S900-316-003
1	151-111	Blower Housing	2
2	144-174	Diffuser	2
3	5152-090	Blower Wheel	X
4	5152-091	Blower Wheel	X
5	105-870	Back Brace	X
6	103-401	Front Brace	X
7	5451-011	Grommets	6
8	S8105-060-0108	Blower Motor 1/3 HP ECM Motor w/Programmed Control	X
8	C8105-060-0108	Programmed Motor Control Only	X
9	8200-031	Motor Mount	X
10	113-314	Blower Motor Control Bracket	X