

# REPLACEMENT PARTS MANUAL

## I-TEC® SERIES PACKAGED HEAT PUMP

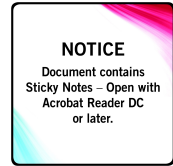

Models:

I36Z1-A	I48Z1-A	I60Z1-A
I36Z1-B	I48Z1-B	I60Z1-B
I36Z1-C	I48Z1-C	I60Z1-C

<b>Description</b>	<b>Page</b>	<b>Description</b>	<b>Page</b>
Wiring Diagram Charts		Vent Box (Only) Components	
• Matrix.....	2	• Exploded View .....	22
Cabinet Components		• Usage List .....	23
• Exploded View .....	4	CRV Components	
• Usage List .....	5	• Exploded View .....	24
Painted Cabinet Components		• Usage List .....	25
• Exploded View .....	6	CRV Blower Components	
• Usage List .....	7	• Exploded View .....	26
Functional Components		• Usage List .....	27
• Exploded View .....	8	Sleeve Components	
• Usage List .....	9	• Exploded View .....	28
• Usage List .....	10	• Usage List .....	29
Blower Assembly		Riser Platform Components	
• Exploded View .....	11	• Exploded View .....	30
• Usage List .....	11	• Usage List .....	31
Control Panel Components - 1 Phase			
• Exploded View .....	12		
• Usage List .....	13		
Control Panel Components - 3 Phase			
• Exploded View .....	14		
• Usage List .....	15		
Control Panel Components - 460V 3 Phase			
• Exploded View .....	16		
• Usage List .....	17		
Electric Heater Components			
• Exploded View .....	18		
• Usage List .....	19		
• Usage List .....	20		
• Usage List .....	21		

### General Notes

- Revised and/or additional pages may be issued from time to time.
- A complete and current manual consists of pages shown in the following contents section.

### Important

- Contact the installing and/or local Bard distributor for all parts requirements. Be sure to have the complete model and serial number available from the unit rating plates.



Bard Manufacturing Company, Inc.  
Bryan, Ohio 43506  
www.bardhvac.com

Manual: 2110-590N  
Supersedes: 2110-590M  
Date: 6-21-17

# I\*\*Z1 SERIES WIRING DIAGRAM MATRIX

Model	Wiring Diagram	Ventilation Package	Wiring Diagram	Heater	Wiring Diagram
I36Z1-A	4202-101H	Commercial Room Ventilator	4204-103A	0KW	4203-100B
		Energy Recovery Ventilator	4204-104B	5KW	4203-101B
		Economizer	4204-105	10KW	4203-103B
				15KW	4203-104B
I36Z1-B	4202-201H	Commercial Room Ventilator	4204-103A	0KW	4203-200B
		Energy Recovery Ventilator	4204-104B	6KW	4203-201C
		Economizer	4204-105	9KW	4203-201C
				15KW	4203-202B
I36Z1-C	4202-301H	Commercial Room Ventilator	4204-103A	0KW	4203-300C
		Energy Recovery Ventilator	4204-104B	6KW	4203-301D
		Economizer	4204-105	9KW	4203-301D
				15KW	4203-302D
I48Z1-A	4202-101H	Commercial Room Ventilator	4204-103A	0KW	4203-100B
		Energy Recovery Ventilator	4204-104B	4KW	4203-101B
		Economizer	4204-105	5KW	4203-102B
				10KW	4203-103B
				15KW	4203-104B
I48Z1-B	4202-201H	Commercial Room Ventilator	4204-103A	0KW	4203-200B
		Energy Recovery Ventilator	4204-104B	6KW	4203-201C
		Economizer	4204-105	9KW	4203-201C
				15KW	4203-202B
				18KW	4203-202B
I48Z1-C	4202-301H	Commercial Room Ventilator	4204-103A	0KW	4203-300C
		Energy Recovery Ventilator	4204-104B	6KW	4203-301D
		Economizer	4204-105	9KW	4203-301D
				15KW	4203-302D
I60Z1-A	4202-101H	Commercial Room Ventilator	4204-103A	0KW	4203-100B
		Energy Recovery Ventilator	4204-104B	4KW	4203-101B
		Economizer	4204-105	5KW	4203-102B
				10KW	4203-103B
				15KW	4203-104B
I60Z1-B	4202-201H	Commercial Room Ventilator	4204-103A	0KW	4203-200B
		Energy Recovery Ventilator	4204-104B	6KW	4203-201C
		Economizer	4204-105	9KW	4203-201C
				15KW	4203-202B
				18KW	4203-203B
I60Z1-C	4202-301H	Commercial Room Ventilator	4204-103A	0KW	4203-300C
		Energy Recovery Ventilator	4204-104B	6KW	4203-301D
		Economizer	4204-105	9KW	4203-301D
				15KW	4203-302D
I36Z1CC	4202-301H	Commercial Room Ventilator	4204-103A	0KW	4203-303A
		Energy Recovery Ventilator	4204-104B	6KW	4203-304A
		Economizer	4204-105	9KW	4203-304A
				15KW	4203-305A
I48Z1CC	4202-301H	Commercial Room Ventilator	4204-103A	0KW	4203-303A
		Energy Recovery Ventilator	4204-104B	6KW	4203-304A
		Economizer	4204-105	9KW	4203-304A
				15KW	4203-305A
I60Z1CC	4202-301H	Commercial Room Ventilator	4204-103A	0KW	4203-303A
		Energy Recovery Ventilator	4204-104B	6KW	4203-304A
		Economizer	4204-105	9KW	4203-304A
				15KW	4203-305A
				18KW	4203-305A

*This page intentionally left blank*

# CABINET COMPONENTS

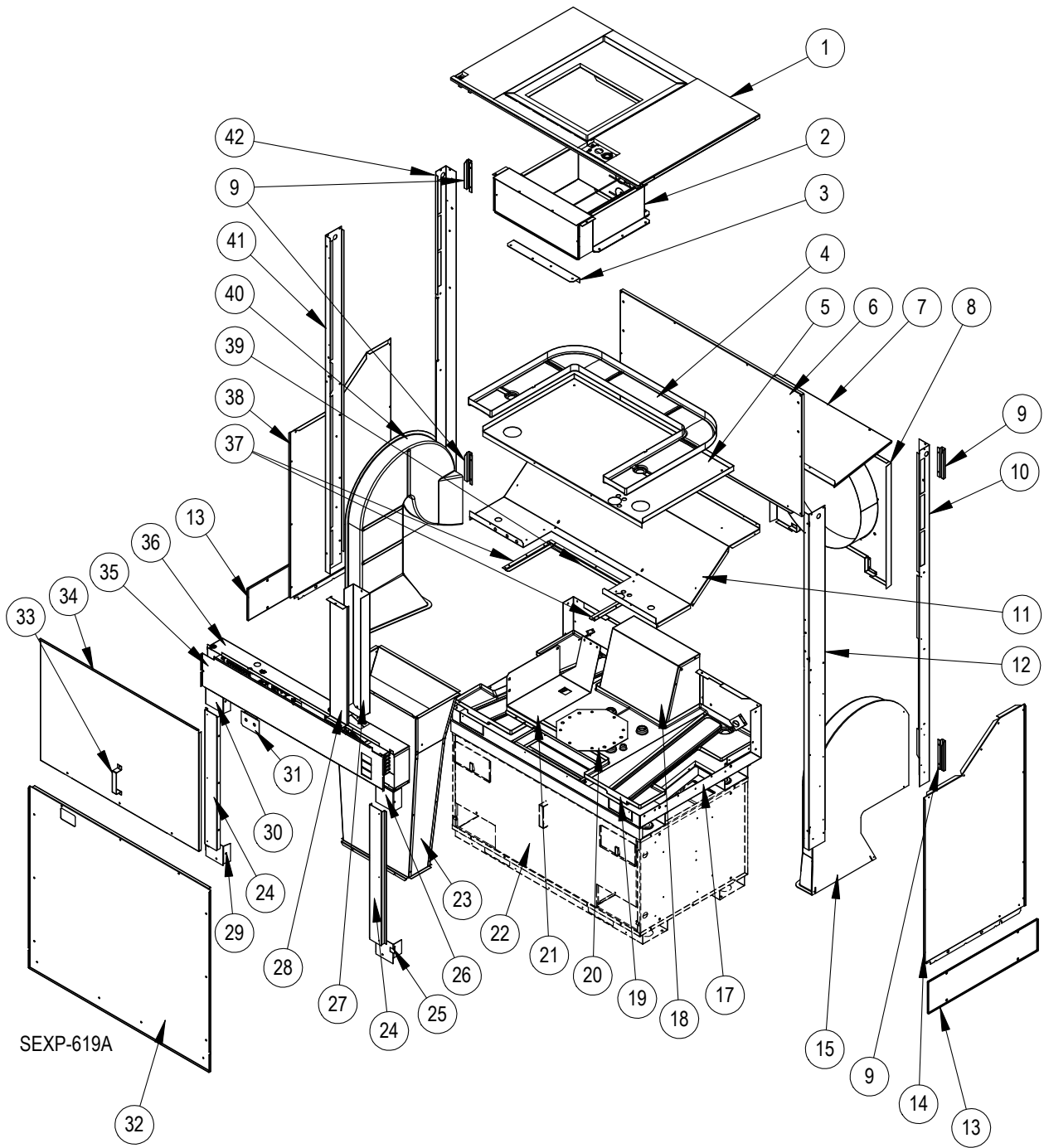

# CABINET COMPONENTS

Drawing No.	Part Number	Description	All Models
1	S507-296	Top Assembly	X
2	See Heater Pkg. Section	Heater Package	X
3	105-1256	Front blower angle	X
4	6096-001	Indoor drain pan	X
5	S141-383	Evap. Coil Support	X
6	509-259-8	Unit Back Assembly	X
7	S137-641	Cond. Coil Top Fill	X
8	S125-065	Fan Shroud/Venturi Assembly	X
9	113-439	Side Bracket	4
10	S149-120	Right Rear Corner	X
11	S121-456	Condenser Partition	X
12	S149-123	Right Front Corner	X
13	113-630	Unit Connection Bracket	2
14	S101X635	Right Inner Side Panel	X
15	7001-026	Right Hand Inlet Duct (used on CRV units only)	X
17	S127-522	Condenser Base Assembly	X
18	S921-0003	Exhaust Duct Assembly	X
19	6096-009	Outdoor Drain Pan	X
20	126-417	Compressor Mounting Base	X
21	113-595	460V trans. Mtg brkt. (I36 & I48)	X
	113-449	460V trans. Mtg brkt. (I60 Only)	X
22	See Vent Section	Vent Option	X
23	511-177	Intake Duct Assembly (used on CRV units only)	X
24	S141-391	Condenser Coil Access Door	X
25	S141X390	Lower Right Condenser Coil Support	X
26	S141X389	Upper Right Condenser Coil Support	X
27	165-603	High Voltage Wire Channel	X
28	143-202	High Voltage Wire Channel Cover	X
29	S141Y390	Lower Left Condenser Coil Support	X
30	S141Y389	Upper Left Condenser Coil Support	X
31	S113-440	Dual Service Port Bracket	X
32	S553-498	Condenser Door	X
33	113-441	Door Latch Bracket	X
34	S553-496	Evaporator Door	X
35	S153-497	Control Panel Door (230V Units)	X
	S153-501	Control Panel Door (460V Units)	X
36	See Control Panel Section	Control Panel	X
37	103-493	Cond. Partition Side Offset	2
38	S101Y635	Left Inner Side Panel	X
39	103-494	Cond. Partition Rear Offset	X
40	7001-027	Left Hand Inlet Duct (used on CRV units only)	X
41	S149-121	Left Front Corner	X
42	S149-122	Left Rear Corner	X
NS	S113-426	Top Mounting Bracket	X

NS = Not Shown

# **PAINTED CABINET COMPONENTS**

---

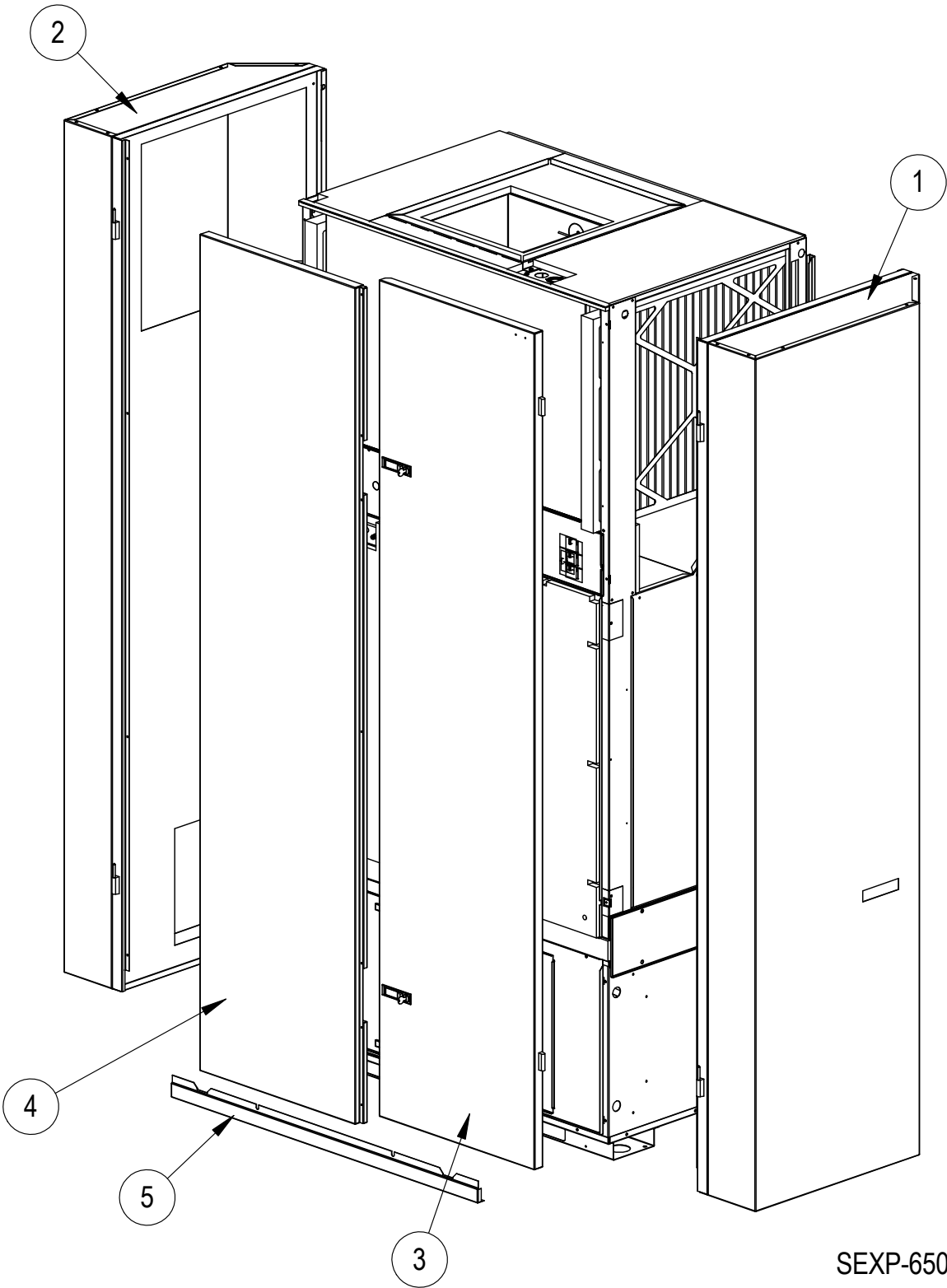

SEXP-650

# PAINTED CABINET COMPONENTS

---

Drawing No.	Part Number	Description	All Models
1	S501-704-*	Right Side	X
2	S501-702-*	Left Side	X
3	S553-531-*	Right Front Door	X
4	S553-532-*	Left Front Door	X
5	115-206-*	Front Unit Trim	X

\* Exterior cabinet parts are manufactured with various paint color options. To ensure the proper paint color is received, reference the following codes:

Beige -X  
White -1  
Buckeye Gray -4

# FUNCTIONAL COMPONENTS

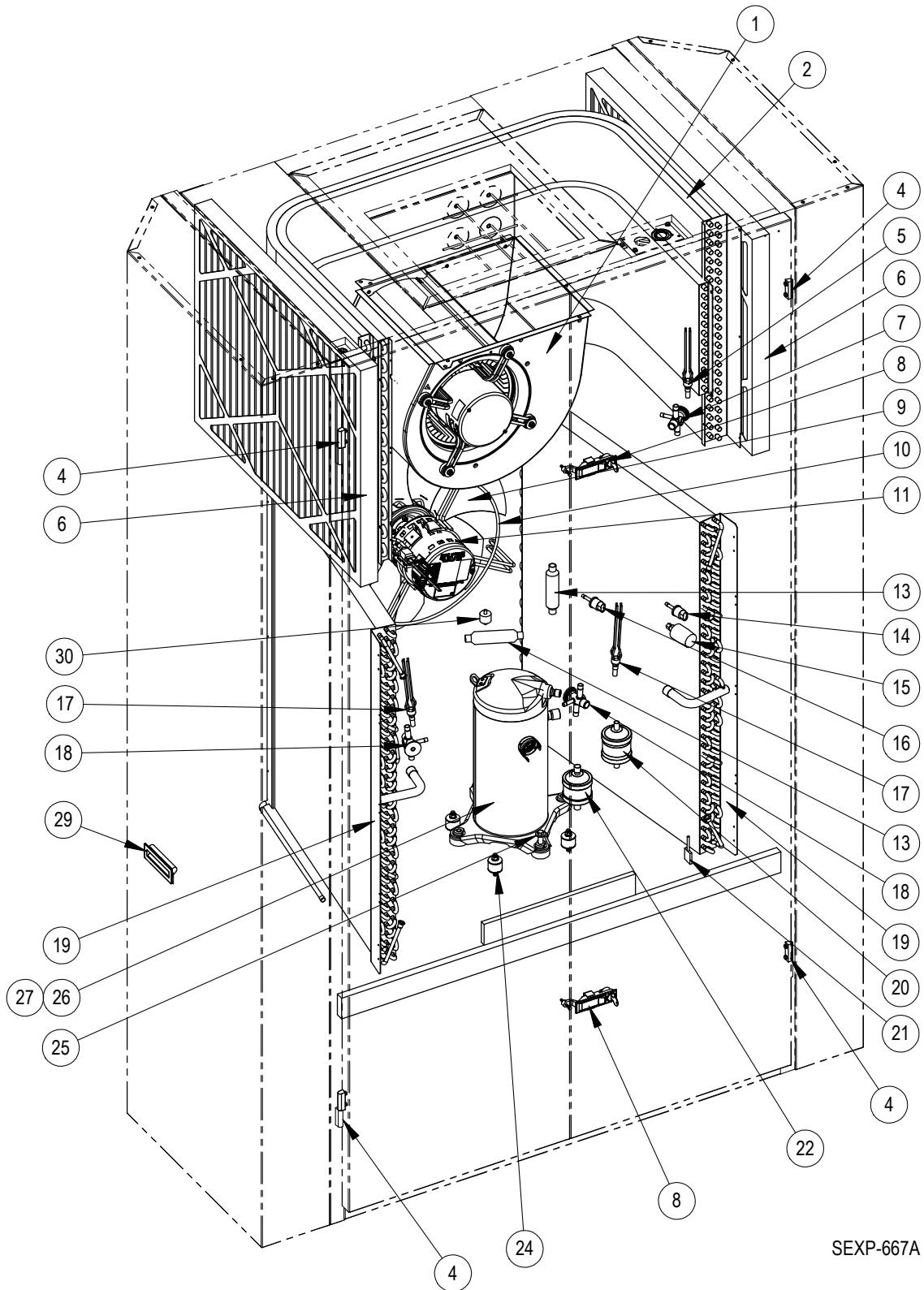

SEXP-667A



# FUNCTIONAL COMPONENTS

Drawing No.	Part Number	Description	I36Z1-A	I36Z1-B	I36Z1-C	I48Z1-A	I48Z1-B	I48Z1-C	I60Z1-A	I60Z1-B	I60Z1-C
1	S5154-005-0089	Complete Blower Assembly	X	X	X						
1	S5154-005-0114	See Blower Section for									
1	S5154-006-0117	Individual Components				X	X	X	X	X	X
2	5060-168BX	Evaporator Coil	X	X	X	X	X	X			
2	5060-175BX	Evaporator Coil							X	X	X
4	5400-006	Polymide Lift-Off Hinge	4	4	4	4	4	4	4	4	4
5	5625-007	Distributor	X	X	X	X	X	X			
5	5625-008	Distributor							X	X	X
6	7004-050	MERV 8 Filter	2	2	2	2	2	2	2	2	2
6	7004-051	MERV 11 Filter	2	2	2	2	2	2	2	2	2
6	7004-053	MERV 13 Filter	2	2	2	2	2	2	2	2	2
7	5651-211	Expansion Valve	X	X	X						
7	5651-212	Expansion Valve				X	X	X			
7	5651-241	Expansion Valve							X	X	X
8	1171-063	Lockable Latch	2	2	2	2	2	2	2	2	2
9	5151-058	Fan Blade	X	X	X	X	X	X	X	X	X
10	8200-045	Fan Mount	X	X	X	X	X	X	X	X	X
11	S8105-058-0095	Programmed Outdoor Motor	X	X	X						
11	S8106-054-0113	Programmed Outdoor Motor				X	X	X			
11	S8105-054-0113	Programmed Outdoor Motor							X	X	X
12	5650-039	Reversing Valve	X	X	X						
12	5650-040	Reversing Valve				X	X	X	X	X	X
14	8406-142	High Pressure Switch	X	X	X	X	X	X	X	X	X
15	8406-112	Low Ambient Control	X	X	X	X	X	X	X	X	X
16	8406-135	Low Pressure Switch	X	X	X	X	X	X	X	X	X
17	5625-013	Distributor	2	2	2						
17	5625-007	Distributor				2	2	2	2	2	2
18	5651-217	Expansion Valve	2	2	2						
18	5651-218	Expansion Valve				2	2	2			
18	5651-200	Expansion Valve							2	2	2
19	5051-171BX	Condenser Coil	2	2	2						
19	5051-172BX	Condenser Coil				2	2	2	2	2	2
20	5201-020	Filter-Drier	X	X	X	X	X	X	X	X	X

# FUNCTIONAL COMPONENTS

---

Drawing No.	Part Number	Description	I36Z1-A	I36Z1-B	I36Z1-C	I48Z1-A	I48Z1-B	I48Z1-C	I60Z1-A	I60Z1-B	I60Z1-C
22	5220-013	Pulsation Dampener / Muffler	X	X	X	X	X	X	X	X	X
24	8001-013	Compressor Grommet	4	4	4	4	4	4	4	4	4
25	1012-328	Compressor Bolt	4	4	4	4	4	4	4	4	4
26	8000-379	Compressor	X								
26	8000-380	Compressor		X							
26	8000-381	Compressor			X						
26	8000-382	Compressor				X					
26	8000-383	Compressor					X				
26	8000-384	Compressor						X			
26	8000-424	Compressor							X		
26	8000-425	Compressor								X	
26	8000-426	Compressor									X
27	8002-012	Compressor Sound Cover	X	X	X						
27	8002-013	Compressor Sound Cover				X	X	X	X	X	X
29	1171-060	Flush Plastic Door Pull	2	2	2	2	2	2	2	2	2
30	5451-018	Motor Mount Grommet	2	2	2	2	2	2	2	2	2
31	5650-046	Rev. Valve Solenoid - Black Casing	X	X	X	X	X	X	X	X	X
NS	6094-011	3/4" Barbed Drain Pan Fitting	4	4	4	4	4	4	4	4	4
NS	6001-016	Nylon Barbed Tee	X	X	X	X	X	X	X	X	X
NS	7950-021	1" Hose Clamp	8	8	8	8	8	8	8	8	8
NS	6031-010	R-410A Tamper Resistant Cap	2	2	2	2	2	2	2	2	2
NS	910-1977	Evap. Overflow Switch Ass'y	X	X	X	X	X	X	X	X	X
NS	6031-009	Coremax Valve Core	X	X	X	X	X	X	X	X	X

# BLOWER ASSEMBLY COMPONENTS

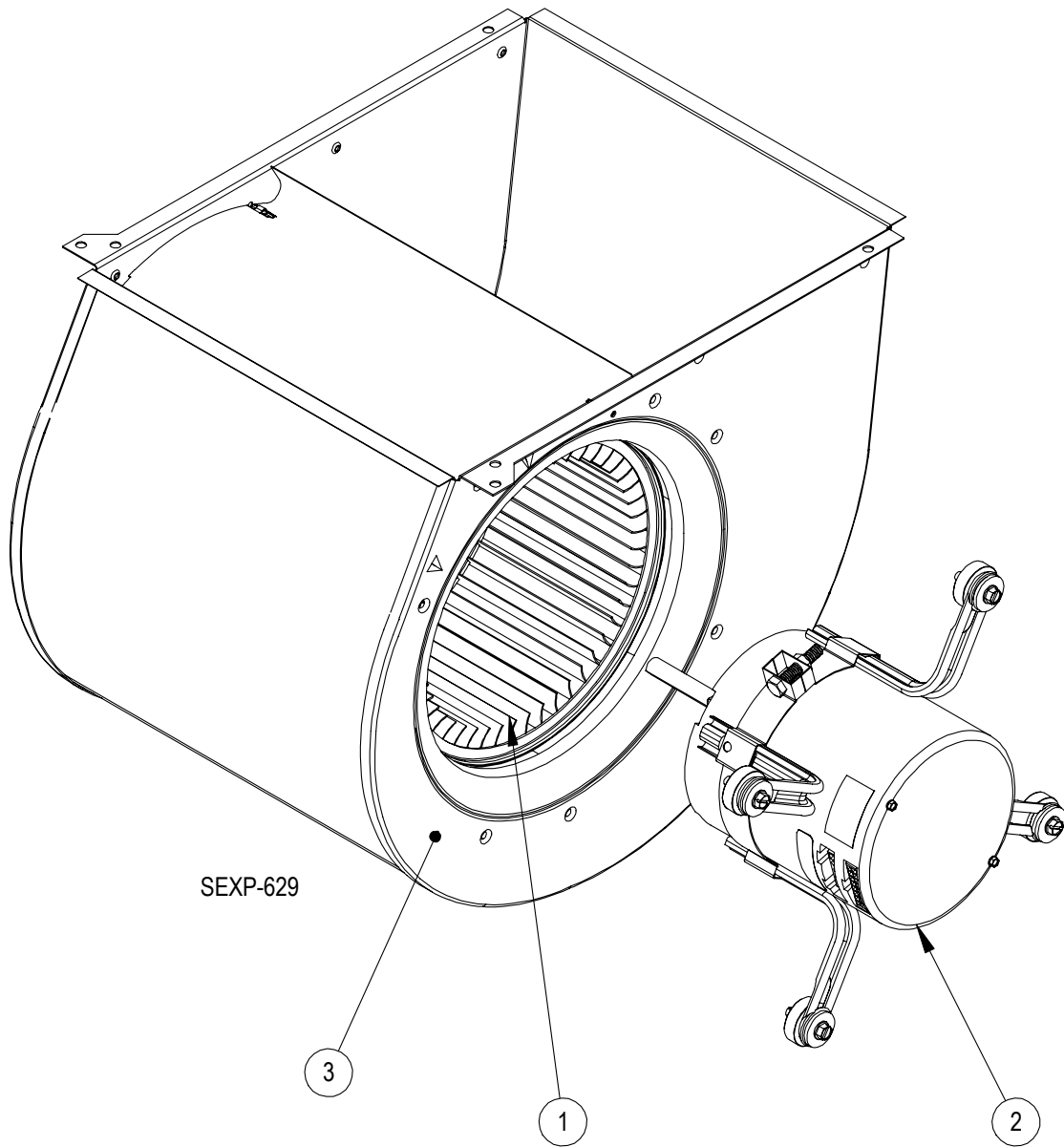

Drawing No.	Part Number	Description	5154-005-0089	5154-005-0087	5154-006-0081
1	5152-049	Blower Wheel	X	X	X
2	S8106-051-0089	3/4 HP Programmed Motor	X	X	X
2	S8106-051-0114	3/4 HP Programmed Motor	X	X	X
2	S8107-016-0117	1 HP Programmed Motor	X	X	X
3	151-122	Housing	X	X	X

# CONTROL PANEL COMPONENTS - 1 PHASE

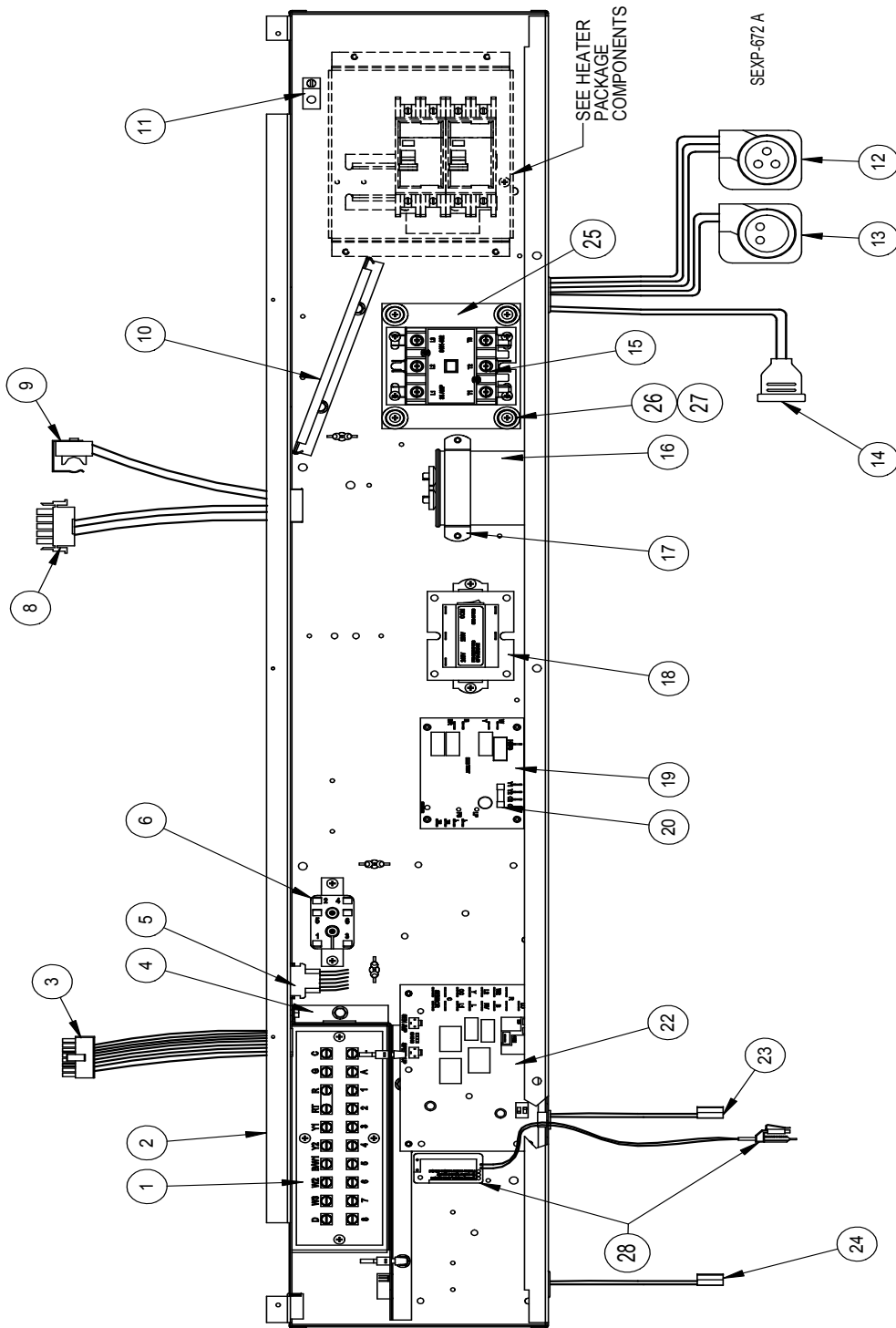

## CONTROL PANEL COMPONENTS – 1 PHASE

Drawing No.	Part Number	Description	136Z1-A	148Z1-A	160Z1-A
1	8607-032	Low Voltage Terminal Strip	X	X	X
2	517-391	Control Panel	X	X	X
3	3000-1396	16 Pin 24V Indoor Blower Motor Control	X	X	X
4	117-319	Low Voltage Terminal Box	X	X	X
5	3000-1397	6 Pin Electric Heat	X	X	X
6	8201-015	Relay	X	X	X
8	3000-1398	5 Pin Indoor Blower Motor Power	X	X	X
9	8408-048	Freeze Protect Thermostat	X	X	X
10	135-319	Wire Shield	X	X	X
11	8611-006	Ground Terminal	X	X	X
12	3000-1222	Compressor Power Plug	X	X	X
13	3000-1223	Compressor Solenoid Plug	X	X	X
14	5650-044	Solenoid Valve Plug	X	X	X
15	8401-025	Contactactor 2 Pole 40 Amp	X	X	X
16	8552-035	Capacitor 40MFD 370V	X		
16	8552-095	Capacitor 30MFD 370V		X	
16	8552-096	Capacitor 40MFD 440V			X
17	8550-007	Capacitor Bracket 2" Round	X		X
17	8550-006	Capacitor Bracket 1-3/4" Round		X	
18	8407-048	Transformer 75VA with Circuit Breaker	X	X	X
19	8201-166	Fan Logic Control	X	X	X
20	8614-052	3.15 Amp Fuse	X	X	X
22	8620-223	Defrost Control Board Kit (includes new sensor)	X	X	X
23	8620-225	Defrost Sensor Kit	X	X	X
24	8408-043	Fan Control Thermistor	X	X	X
25	116-332	Contactactor Isolation Plate	X	X	X
26	5451-025	Rubber Grommet	4	4	4
27	5451-026	Nylon Flanged Bushing	4	4	4
28	910-1914	Overflow Switch Assembly	X	X	X

# CONTROL PANEL COMPONENTS – 3 PHASE

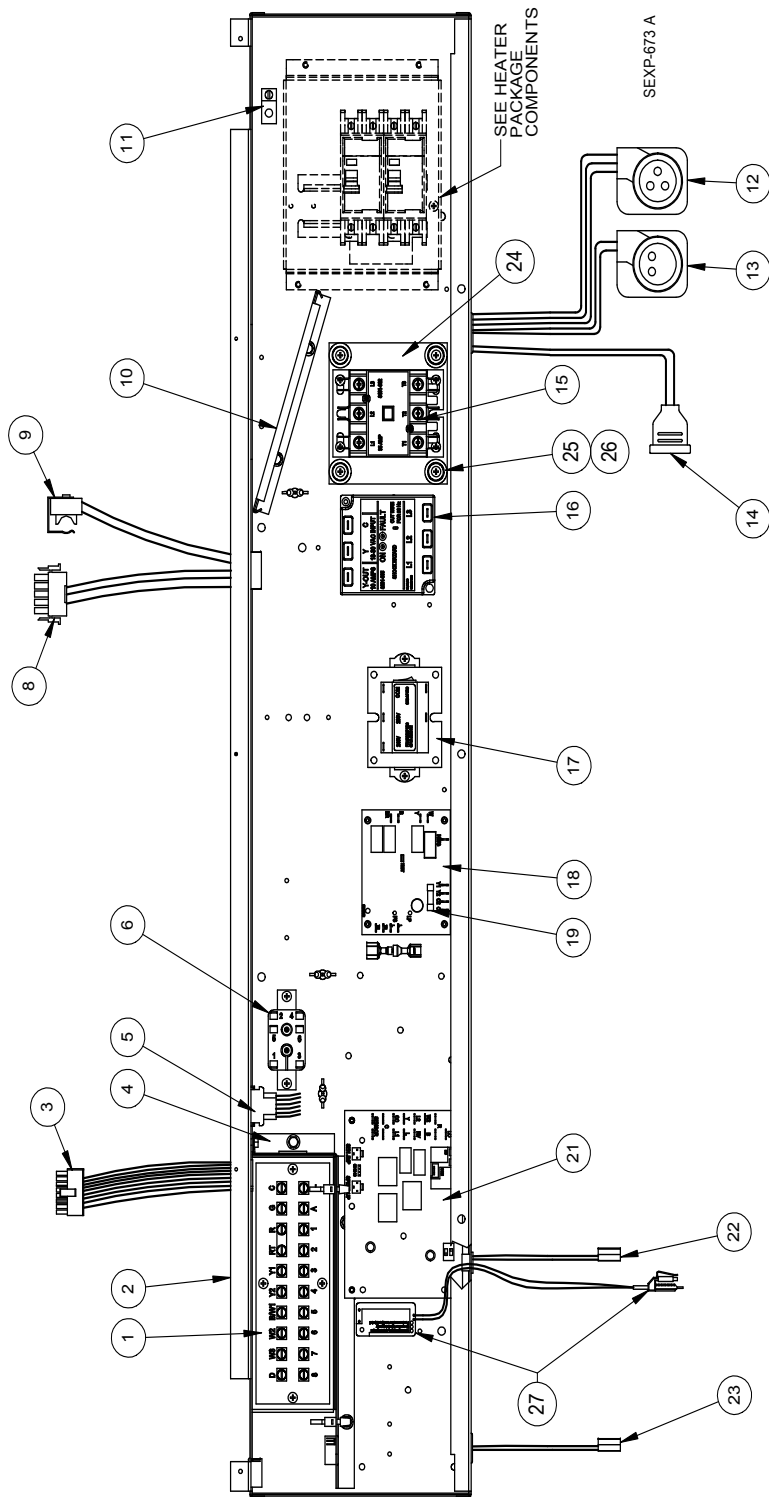

## CONTROL PANEL COMPONENTS – 3 PHASE

---

Drawing No.	Part Number	Description	I36Z1-B	I48Z1-B	I60Z1-B
1	8607-032	Low Voltage Terminal Strip	X	X	X
2	517-391	Control Panel	X	X	X
3	3000-1396	16 Pin 24V Indoor Blower Motor Control	X	X	X
4	117-319	Low Voltage Terminal Box	X	X	X
5	3000-1397	6 Pin Electric Heat	X	X	X
6	8201-015	Relay	X	X	X
8	3000-1398	5 Pin Indoor Blower Motor Power	X	X	X
9	8408-048	Freeze Protect Thermostat	X	X	X
10	135-319	Wire Shield	X	X	X
11	8611-006	Ground Terminal	X	X	X
12	3000-1231	Compressor Power Plug	X	X	X
13	3000-1223	Compressor Solenoid Plug	X	X	X
14	5650-044	Solenoid Valve Plug	X	X	X
15	8401-002	Contactora 3 Pole 25 Amp	X	X	X
16	8201-126	3-PH Line Monitor	X	X	X
17	8407-048	Transformer 75VA with Circuit Breaker	X	X	X
18	8201-166	Fan Logic Control	X	X	X
19	8614-052	3.15 Amp Fuse	X	X	X
21	8620-223	Defrost Control Board Kit (includes new sensor)	X	X	X
22	8620-225	Defrost Sensor Kit	X	X	X
23	8408-043	Fan Control Thermistor	X	X	X
24	116-332	Contactora Isolation Plate	X	X	X
25	5451-025	Rubber Grommet	4	4	4
26	5451-026	Nylon Flanged Bushing	4	4	4
27	910-1914	Overflow Switch Assembly	X	X	X





## CONTROL PANEL COMPONENTS – 460V 3 PHASE

Drawing No.	Part Number	Description	I36Z1-C	I48Z1-C	I60Z1-C
1	8607-032	Low Voltage Terminal Strip	X	X	X
2	517-391	Control Panel	X	X	X
3	3000-1396	16 pin 24V Indoor Blower Motor Control	X	X	X
4	117-319	Low Voltage terminal box	X	X	X
5	3000-1397	6 Pin Elect. Heat	X	X	X
6	8201-015	Relay	X	X	X
8	8614-041	Fuse Block	X	X	X
9	<i>See separate chart below for Item #9</i>				
10	8607-017	Terminal Block	X	X	X
11	3000-1398	5 Pin Indoor Blower Motor Power	X	X	X
12	8408-048	Freeze Protect Thermostat	X	X	X
13	135-319	Wire Shield	X	X	X
14	8611-006	Ground Terminal	X	X	X
15	3000-1231	Compressor Power Plug	X	X	X
16	3000-1223	Compressor Solenoid Plug	X	X	X
17	5650-044	Solenoid Valve Plug	X	X	X
18	8401-002	Contactactor 3 Pole 25 Amp	X	X	X
19	8201-126	3-PH Line Monitor	X	X	X
20	8407-048	Transformer 75VA with Circuit Breaker	X	X	X
21	8201-166	Fan Logic Control	X	X	X
22	8614-052	3.15 Amp Fuse	X	X	X
24	8620-223	Defrost Control Board Kit (includes new sensor)	X	X	X
25	8620-225	Defrost Sensor Kit	X	X	X
26	8408-043	Fan Control Thermistor	X	X	X
27	116-332	Contactactor Isolation Plate	X	X	X
28	5451-025	Rubber Grommet	4	4	4
29	5451-026	Nylon Flanged Bushing	4	4	4
30	910-1914	Overflow Switch Assembly	X	X	X

### With Vent

### No Vent

9	I36Z1-C	(2) Part #8614-042 7A Class CC Fuse	(2) Part #8614-046 5A Class Fuse
	I48Z1-C	(2) Part #8614-042 7A Class CC Fuse	(2) Part #8614-046 5A Class CC Fuse
	I60Z1-C	(2) Part #8614-043 10A Class CC Fuse	(2) Part #8614-042 7A Class CC Fuse

# ELECTRIC HEATER COMPONENTS

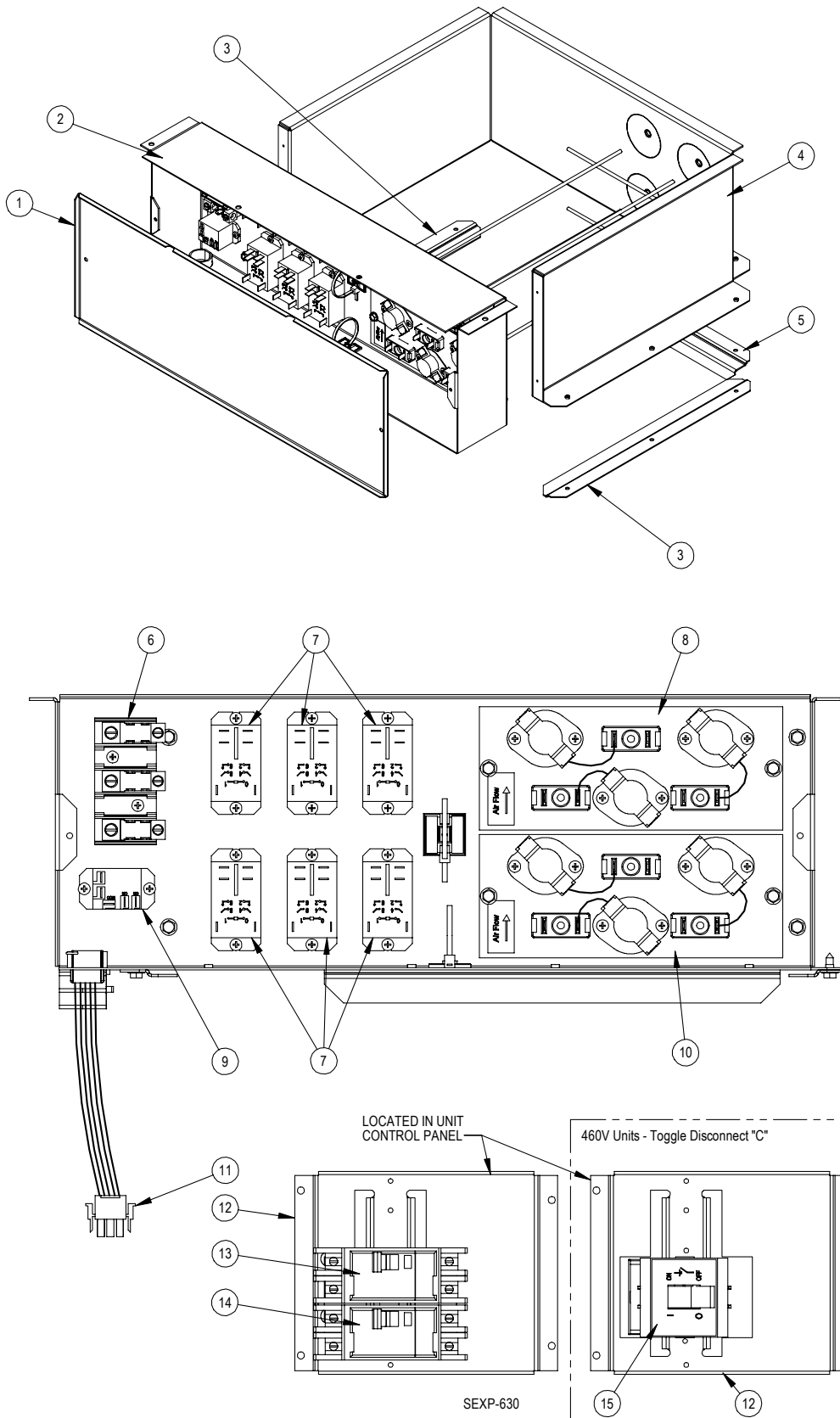

## ELECTRIC HEATER COMPONENTS

Drawing No.	Part Number	Description	I36Z1-A0Z	I36Z1-A05	I36Z1-A10	I36Z1-A15	I48Z1-A0Z	I48Z1-A04	I48Z1-A05	I48Z1-A10	I48Z1-A15	I48Z1-A20	I60Z1-A0Z	I60Z1-A05	I60Z1-A10	I60Z1-A15	I60Z1-A20
1	143-148	Heater Box Cover	X	X	X	X	X	X	X	X	X	X	X	X	X	X	X
2	117-313	Heater Front Plate	X	X	X	X	X	X	X	X	X	X	X	X	X	X	X
3	103-486	Side Blower Offset	2	2	2	2	2	2	2	2	2	2	2	2	2	2	2
4	117-307	Heater Wrapper	X	X	X	X	X	X	X	X	X	X	X	X	X	X	X
5	103-487	Rear Blower Angle	X	X	X	X	X	X	X	X	X	X	X	X	X	X	X
7	8401-036	Contactora 2-Pole 30A		X	2	3		X	X	2	3	4		X	2	3	4
8	142-159	Heater Blank Off Plate	X	X	X		X	X	X	X			X	X	X		
8	8604-135	Heat Strip 5KW				X					X					X	
8	8604-136	Heat Strip 10KW										X					X
9	8201-130	Relay		X	X	X		X	X	X	X	X		X	X	X	X
10	142-159	Heater Blank Off Plate	X				X						X				
10	8604-135	Heat Strip 5KW		X					X					X			
10	8604-136	Heat Strip 10KW			X	X				X	X	X			X	X	X
10	8604-134	Heat Strip 4KW					X	X									
11	3000-1402	6-Pin Electric Heater Wire Harness		X	X	X		X	X	X	X	X		X	X	X	X
12	127-418	Circuit Breaker Base	X	X	X	X	X	X	X	X	X	X	X	X	X	X	X
13	8615-037	Circuit Breaker 30A 2-Pole							X					X			
13	8615-041	Circuit Breaker 60A 2-Pole			X	X				X	X	X			X	X	X
14	8615-040	Circuit Breaker 50A 2-Pole					X		X								
14	8615-055	Circuit Breaker 40A 2-Pole	X		X	X											
14	8615-041	Circuit Breaker 60A 2-Pole		X				X				X	X	X	X	X	X
14	8615-039	Circuit Breaker 45A 2-Pole								X	X						

NS = Not Shown

# ELECTRIC HEATER COMPONENTS

Drawing No.	Part Number	Description	I36Z1-B0Z	I36Z1-B06	I36Z1-B09	I36Z1-B15	I48Z1-B0Z	I48Z1-B06	I48Z1-B09	I48Z1-B15	I48Z1-B18	I60Z1-B0Z	I60Z1-B06	I60Z1-B09	I60Z1-B15	I60Z1-B18
1	143-148	Heater Box Cover	X	X	X	X	X	X	X	X	X	X	X	X	X	X
2	117-313	Heater Front Plate	X	X	X	X	X	X	X	X	X	X	X	X	X	X
3	103-486	Side Blower Offset	2	2	2	2	2	2	2	2	2	2	2	2	2	2
4	117-307	Heater Wrapper	X	X	X	X	X	X	X	X	X	X	X	X	X	X
5	103-487	Rear Blower Angle	X	X	X	X	X	X	X	X	X	X	X	X	X	X
6	8607-014	Terminal Block									X					X
7	8401-036	Contactora 2-Pole 30A		3	3	6		3	3	6	6		3	3	6	6
8	142-159	Heater Blank Off Plate	X	X	X		X	X	X			X	X	X		
8	8604-137	Heat Strip 6KW				X				X					X	
8	8604-138	Heat Strip 9KW									X					X
9	8201-130	Relay		X	X	X		X	X	X	X		X	X	X	X
10	142-159	Heater Blank Off Plate	X				X					X				
10	8604-137	Heat Strip 6KW		X				X					X			
10	8604-138	Heat Strip 9KW			X	X			X	X	X			X	X	X
11	3000-1402	6-Pin Electric Heater Wire Harness		X	X	X		X	X	X	X		X	X	X	X
12	127-418	Circuit Breaker Base		X	X	X	X	X	X	X	X	X	X	X	X	X
13	8615-046	Circuit Breaker 60A 3-Pole				X				X					X	X
14	8615-042	Circuit Breaker 35A 3-Pole					X									
14	8615-052	Circuit Breaker 30A 3-Pole	X													
14	8615-044	Circuit Breaker 45A 3-Pole		X		X				X		X			X	X
14	8615-045	Circuit Breaker 50A 3-Pole			X			X								
14	8615-046	Circuit Breaker 60A 3-Pole							X		X		X	X		

NS = Not Shown

# ELECTRIC HEATER COMPONENTS

Drawing No.	Part Number	Description	I36Z1-C0Z	I36Z1-C06	I36Z1-C09	I36Z1-C15	I48Z1-C0Z	I48Z1-C06	I48Z1-C09	I48Z1-C15	I48Z1-C18	I60Z1-C0Z	I60Z1-C06	I60Z1-C09	I60Z1-C15	I60Z1-C18
1	143-148	Heater Box Cover	X	X	X	X	X	X	X	X	X	X	X	X	X	X
2	117-313	Heater Front Plate	X	X	X	X	X	X	X	X	X	X	X	X	X	X
3	103-486	Side Blower Offset	2	2	2	2	2	2	2	2	2	2	2	2	2	2
4	117-307	Heater Wrapper	X	X	X	X	X	X	X	X	X	X	X	X	X	X
5	103-487	Rear Blower Angle	X	X	X	X	X	X	X	X	X	X	X	X	X	X
6	8607-014	Terminal Block				X									X	
7	8401-036	Contactor 2-Pole 30A		2	2	6		2	2	6	4		2	2	6	4
8	142-159	Heater Blank Off Plate	X	X	X		X	X	X			X	X	X		
8	8604-139	Heat Strip 6KW				X				X					X	
8	8604-140	Heat Strip 9KW														X
9	8201-130	Relay		X	X	X		X	X		X	X	X			X
10	142-159	Heater Blank Off Plate	X				X					X				
10	8604-139	Heat Strip 6KW		X			X					X				
10	8604-140	Heat Strip 9KW			X	X		X	X	X				X	X	X
11	3000-1402	6-Pin Electric Heater Wire Harness		X	X	X		X	X	X	X		X	X	X	X
12	127-418	Circuit Breaker Base	X	X	X	X	X	X	X	X	X	X	X	X	X	X
14	<i>See separate chart below for Item #14</i>															
15	8615-067	Toggle Disconnect 40A 460V	X	X	X	X	X	X	X	X	X	X	X	X	X	X

NS = Not Shown

			I36Z1CC0Z	I36Z1CC06	I36Z1CC09	I36Z1CC15	I48Z1CC0Z	I48Z1CC06	I48Z1CC09	I48Z1CC15	I48Z1CC18	I60Z1CC0Z	I60Z1CC06	I60Z1CC09	I60Z1CC15	I60Z1CC18
14	8615-062	Circuit Breaker 15A	X													
	8615-063	Circuit Breaker 20A		X			X					X				
	8615-064	Circuit Breaker 25A			X											
	8615-065	Circuit Breaker 30A				X		X	X	X	X		X	X	X	X

# VENT BOX (ONLY) COMPONENTS

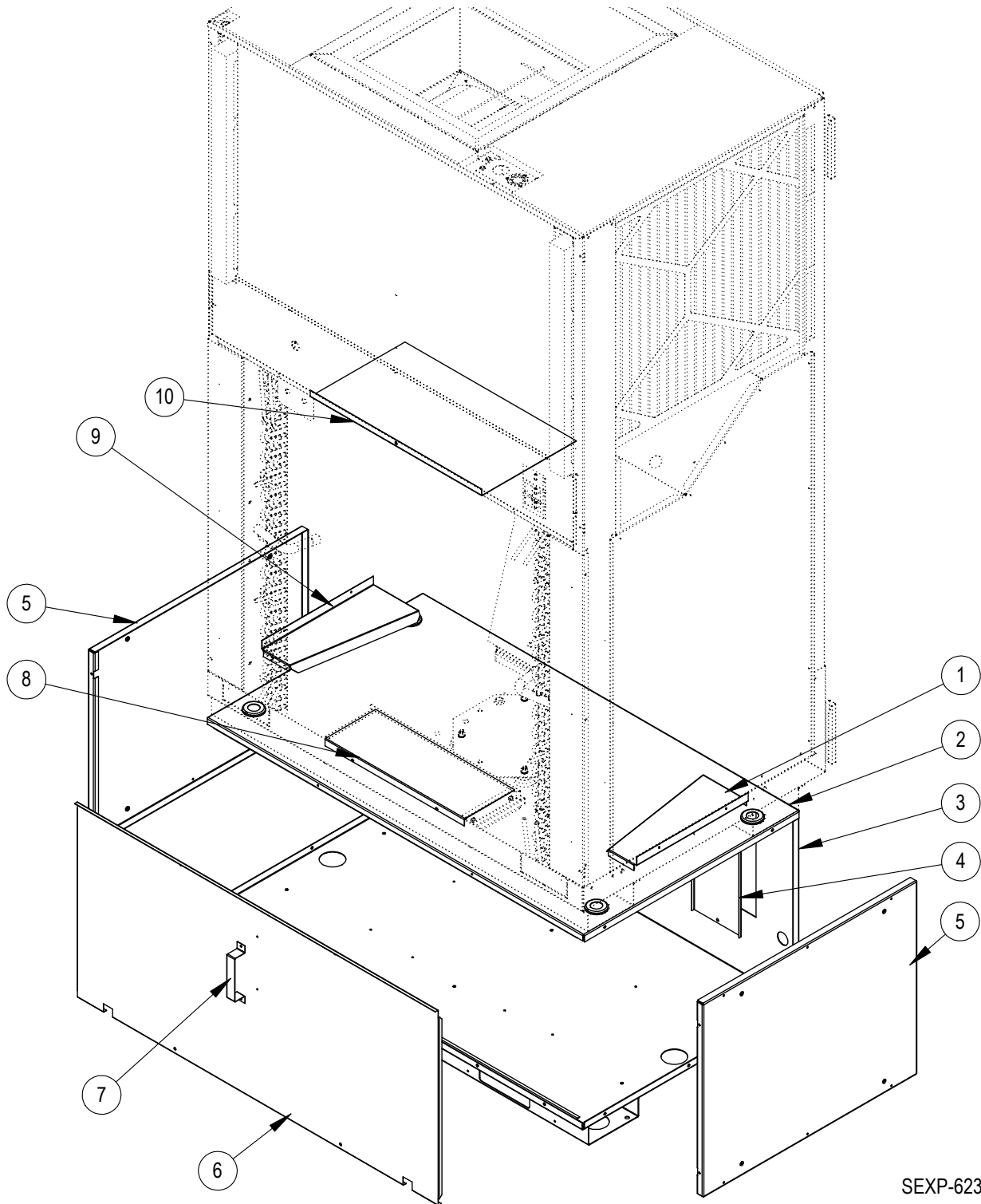

SEXP-623

## **VENT BOX (ONLY) COMPONENTS**

---

<b>Drawing No.</b>	<b>Part Number</b>	<b>Description</b>	<b>Vent Box Only</b>
1	S143X164	Right Side Intake Fill	X
2	507-298	Vent Box Top	X
3	S527-419	Vent Box Base	X
4	543-158	Drain Access Plate	2
5	S501-639	Vent Box Side	2
6	553-508	Vent Box Door	X
7	113-441	Door Latch Bracket	X
8	S143-160	Lower Intake Fill	X
9	S143Y164	Left Side Intake Fill	X
10	S143-161	Upper Intake Fill	X

# CRV COMPONENTS

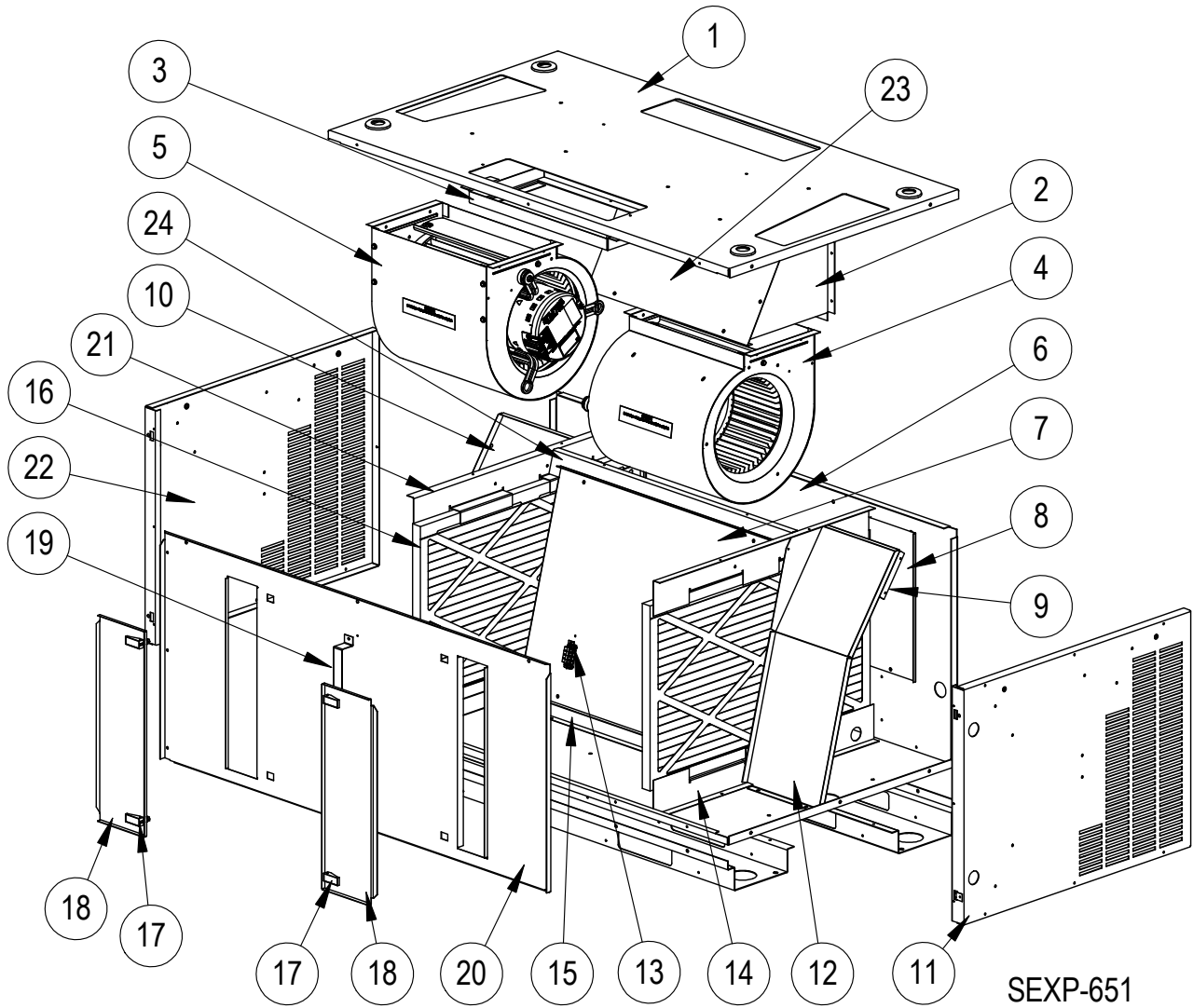



# CRV COMPONENTS

Drawing No.	Part Number	Description	No. Required
1	S507-297	Vent Box Top	1
2	103-489	Rear Blower Offset	1
3	103-488	Front Blower Offset	1
4	900-318-003	Exhaust Blower Assy	1
5	900-318-004	Intake Blower Assy	1
6	S527-419	Vent Box Base	1
7	521-476	Center Partition	1
8	543-158	Drain Access Plate	2
9	105-1290	Partition Angle	2
10	521-477	Left Side Partition	1
11	501-706	Right Side	1
12	521-478	Right Side Partition	1
13	S910-1809	Terminal Block Assembly	1
14	113-477	Lower Filter Bracket	2
15	105-1291	Lower Partition Support Angle	1
16	7004-011	16 X 25 Filter	2
17	1171-053	Swell Latch	4
18	553-534	Filter Door	2
19	113-441	Door Latch Bracket	1
20	553-533	Blower Door	1
21	113-478	Upper Filter Bracket	2
22	501-707	Left Side	1
23	137-671	Rear Blower Fill Plate	1
24	105-1292	Upper Partition Support Angle	1

NS = Not Shown

# CRV BLOWER COMPONENTS

---

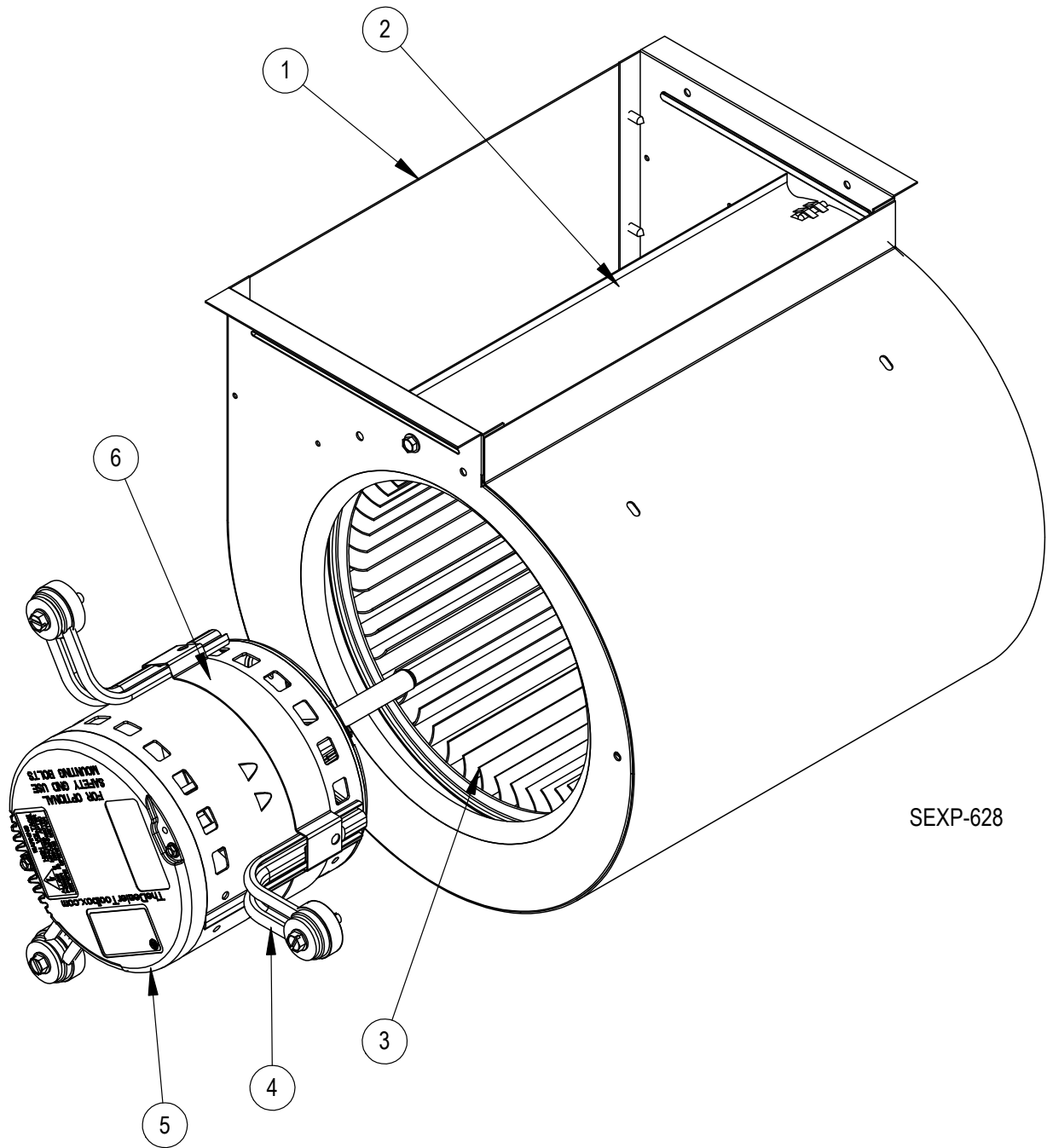

SEXP-628

# CRV BLOWER COMPONENTS

---

Drawing No.	Part Number	Description	900-318-003	900-318-004
1	151-124	Blower Housing	X	X
2	144-129	Diffuser	X	X
3	5152-067	Blower Wheel	X	X
4	8200-046	Motor Mount Arm	3	3
5	S8105-056-0112	1/3 HP Programmed Motor – CRV Exhaust		X
5	S8105-056-0111	1/3 HP Programmed Motor – CRV Intake	X	
6	8620-034	Motor Mount Band	X	X

# SLEEVE COMPONENTS

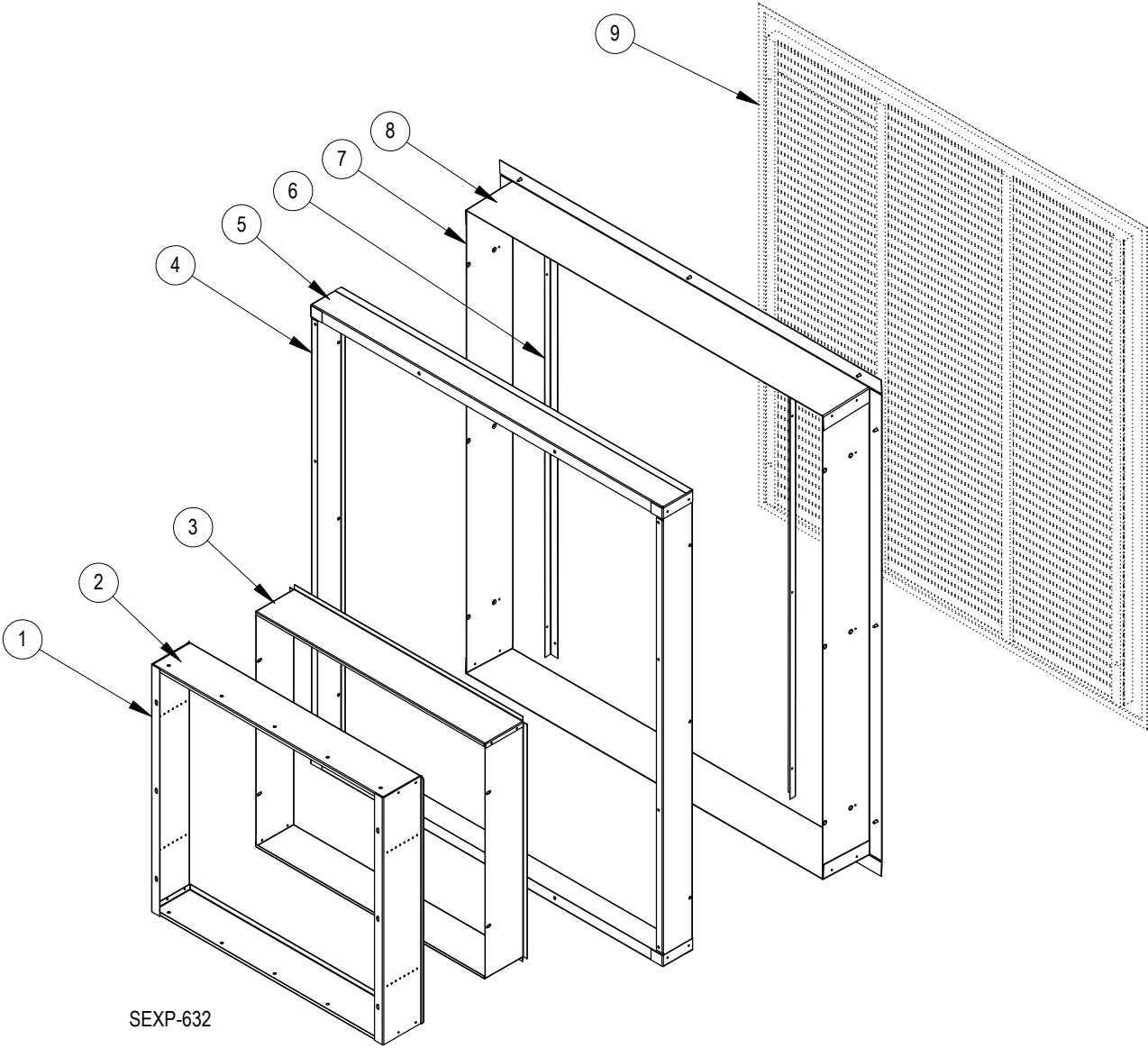

SEXP-632

# SLEEVE COMPONENTS

Drawing No.	Part Number	Description	IWS-A	IWS-B	IWS-C
1	S111-188-8 4½" Deep	Outer Sleeve Side	X		
1	S111-195-8 7" Deep	Outer Sleeve Side		X	
1	S111-202-8 12" Deep	Outer Sleeve Side			X
2	S111-187-8 4½" Deep	Outer Sleeve End	X		
2	S111-194-8 7" Deep	Outer Sleeve End		X	
2	S111-201-8 12" Deep	Outer Sleeve End			X
3	111-189-8 4½" Deep	Inner Fan Sleeve Side	2		
3	111-196-8 7" Deep	Inner Fan Sleeve Side		2	
3	111-203-8 12" Deep	Inner Fan Sleeve Side			2
4	111-186-8 3½" Deep	Inner Sleeve Side	X		
4	111-193-8 6" Deep	Inner Sleeve Side		X	
4	111-200-8 11" Deep	Inner Sleeve Side			X
5	111-185-8 3½" Deep	Inner Sleeve End	X		
5	111-192-8 6" Deep	Inner Sleeve End		X	
5	111-199-8 11" Deep	Inner Sleeve End			X
6	105-1257-8	Grille Support Angle	2	2	2
7	111-184-8 5½" Deep	Outer Sleeve Side	X		
7	111-191-8 8" Deep	Outer Sleeve Side		X	
7	111-198-8 13" Deep	Outer Sleeve Side			X
8	111-183-8 5½" Deep	Outer Sleeve End	X		
8	111-190-8 8" Deep	Outer Sleeve End		X	
8	111-197-8 13" Deep	Outer Sleeve End			X
9	ILG-10	Outdoor Louver Grille - Clear anodized	X	X	X
9	ILG-20	Outdoor Louver Grille - Medium Bronze	X	X	X
9	ILG-30	Outdoor Louver Grille - Dark Bronze	X	X	X

# RISER PLATFORM COMPONENTS

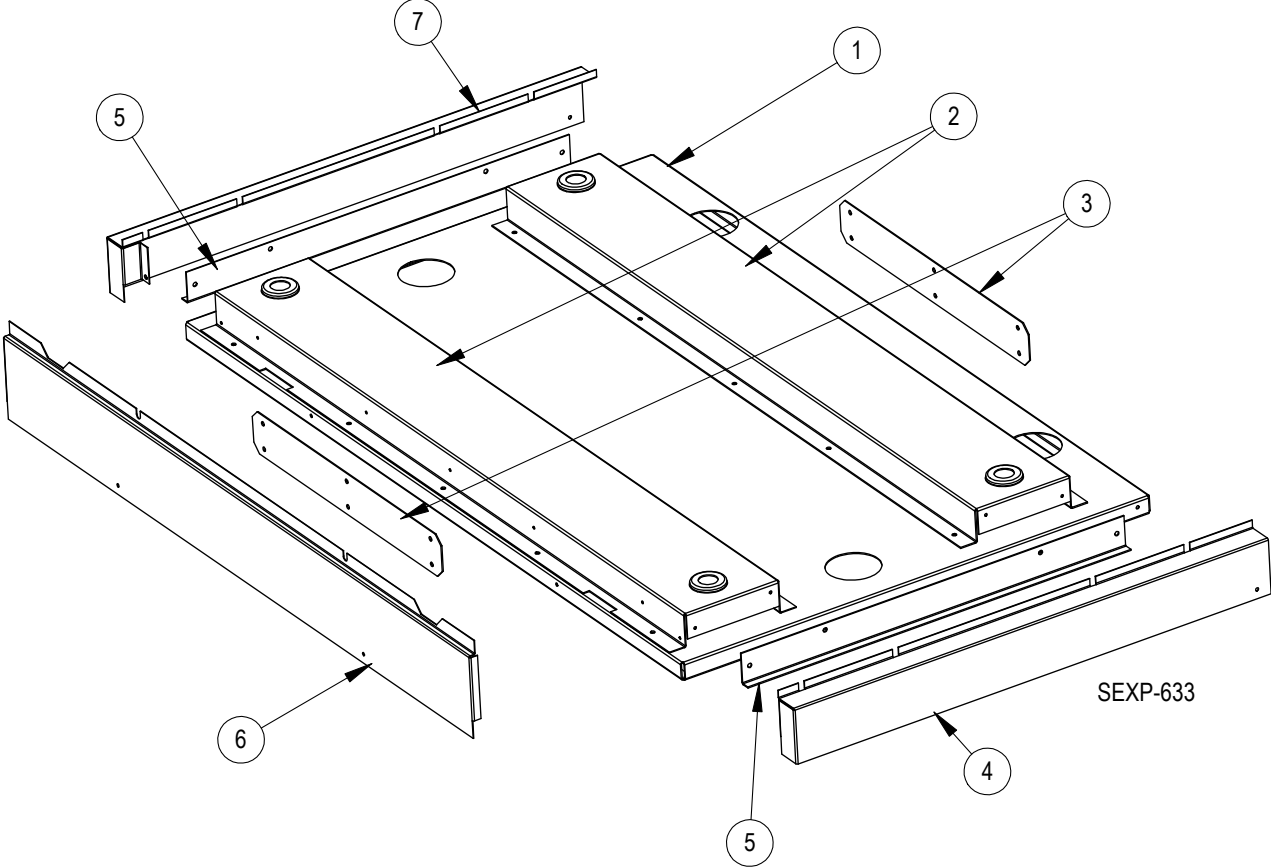

# RISER PLATFORM COMPONENTS

Drawing No.	Part Number	Description	IRP-3-*	IRP-6-*	IRPZ-3-*	IRPZ-6-*
1	127-420-X	Base Plate	X	X	X	X
2	141-384 3"	Base Rail	2		2	
2	141-385 6"	Base Rail		2		2
3	112-447	Base Connection Plate	2	2		
4	135-311-* 3"	Right Side Trim	X			
4	135-314-* 6"	Right Side Trim		X		
4	135-352-x	Right Side Trim			X	
4	135-353-x	Right Side Trim				X
5	105-1263 3"	Side Support Angle	2		2	
5	105-1264 6"	Side Support Angle		2		2
6	135-309-* 3"	Front Trim	X		X	
	135-312-* 6"	Front Trim		X		X
7	135-310-* 3"	Left Side Trim	X			
7	135-313-* 6"	Left Side Trim		X		
7	135-351-x	Left Side Trim			X	
7	135-354-x	Left Side Trim				X

\* Exterior cabinet parts are manufactured with various paint color options. To ensure the proper paint color is received, reference the following codes:

Beige -X  
 White -1  
 Buckeye Gray -4