REPLACEMENT PARTS MANUAL

WALL MOUNTED PACKAGED AIR CONDITIONER

Models:

H42A2-A H48A2-A H60A2-A

General Notes

- Revised and/or additional pages may be issued from time to time.
- A complete and current manual consists of pages shown in the following contents section.

Important

- Contact the installing and/or local Bard distributor for all parts requirements. Make sure you have the complete model and serial number available from the unit rating plates.

Contents

Description	Page
Cabinet Components	
♦ Exploded View	2
♦ Usage List	3
Functional Components	
♦ Exploded View	4
♦ Usage List	5
Control Panel	
♦ Exploded View	6
♦ Usage List	7
Blower Assembly	
♦ Exploded View	8
♦ Usage List	8



Bard Manufacturing Company, Inc.
Bryan, Ohio 43506
www.bardhvac.com

Manual: 2110-591D
Supersedes: 2110-591C
Date: 10-09-14

CABINET COMPONENTS

Dwg No.	Part Number	Description	H42A2-A	H48A2-A	H60A2-A
1	S127-425	Lower Base	X	X	X
1	S127-430 ③	Lower Base	X	X	X
2	S501-686-* ①	Left Side	X	X	X
2	S501-699 ②	Left Side	X	X	X
2	S501-701 ③	Left Side	X	X	X
3	S501-677-* ①	Right Side	X	X	X
3	S501-698 ②	Right Side	X	X	X
3	S501-700 ③	Right Side	X	X	X
4	S508-098	Back	X	X	X
4	S508-275 ②	Back	X	X	X
4	S508-221 ③	Back	X	X	X
5	S507-307-* ①	Top	X	X	X
5	S507-309 ②	Top	X	X	X
5	S507-310 ③	Top	X	X	X
6	S515-230-* ①	Upper Front	X	X	X
6	S514-231 ②	Upper Front	X	X	X
6	S514-232 ③	Upper Front	X	X	X
7	S553-522-* ①	Vent Option Door	X	X	X
7	S553-529-* ①	Vent Option Door with ERV	X	X	X
7	S553-525 ②	Vent Option Door	X	X	X
7	S553-527 ③	Vent Option Door	X	X	X
8	118-048-* ①	Condenser Grille	X	X	X
8	118-064 ②	Condenser Grille	X	X	X
8	118-072 ③	Condenser Grille	X	X	X
9	118-057-* ①	Side Grille	2	2	2
9	118-063 ②	Side Grille	2	2	2
9	118-073 ③	Side Grille	2	2	2
10	S521X462	Condenser Partition	X	X	X
11	S123-122	Drain Pan	X	X	X
11	S123-125 ②③	Drain Pan	X	X	X
12	121X463	Blower Partition	X	X	X
13	Control Panel Assy.	See Control Panel Assy. Drawing & Parts List	X	X	X
14	S132-114	Control Panel Cover (Inner)	X	X	X
15	S533-225-* ①	Control Panel Cover (Outer)	X	X	X
15	S533-229 ②	Control Panel Cover (Outer)	X	X	X
15	S533-230 ③	Control Panel Cover (Outer)	X	X	X
16	S153-218-* ①	Disconnect Access Door	X	X	X
16	S153-387 ②	Disconnect Access Door	X	X	X
16	S153-405 ③	Disconnect Access Door	X	X	X
17	125-024	Fan Shroud	X	X	X
17	125-058 ③	Fan Shroud	X	X	X
18	113-140	Bottom Mounting Bracket	X	X	X
19	137-209	Fill	X	X	X
20	BFAD-5	Fresh Air Damper Assembly	X	X	X
22	S131X164	Filter Tray	X	X	X
23	105X877	Left Side Support	X	X	X
24	147-046	Left Evaporator Support	X	X	X
25	135-128	Raceway	2	2	2
26	S111X034	Outlet Air Frame Assembly	X	X	X
27	105X878	Right Side Support	X	X	X
28	S543-172-* ①	Right Side Cover Plate (Outer)	X	X	X
28	S543-176 ②	Right Side Cover Plate (Outer)	X	X	X
28	S543-177 ③	Right Side Cover Plate (Outer)	X	X	X
29	135-129	Heat Shield	X	X	X
30	113-150-* ①	Top Rain Flashing	X	X	X
30	113-359 ③	Top Rain Flashing	X	X	X
31	S536-258	Cond. Partition Block Off Plate	X	X	X
32	S553-521-* ①	Filter Door Assembly	X	X	X
32	S553-526 ②	Filter Door Assembly	X	X	X
32	S553-528 ③	Filter Door Assembly	X	X	X
33	105-1302	Grommet Retainer	X	X	X
NS	105-1324	Close-Off Angle	X	X	X

① Exterior cabinet parts are manufactured with various paint color options. To ensure the proper paint color is received, include the complete model and serial number of the unit for which cabinet parts are being ordered.

② Exterior cabinet parts are manufactured from aluminum Code "A"

③ Exterior cabinet parts are manufactured from stainless steel Code "S"

NS = Not Shown

FUNCTIONAL COMPONENTS

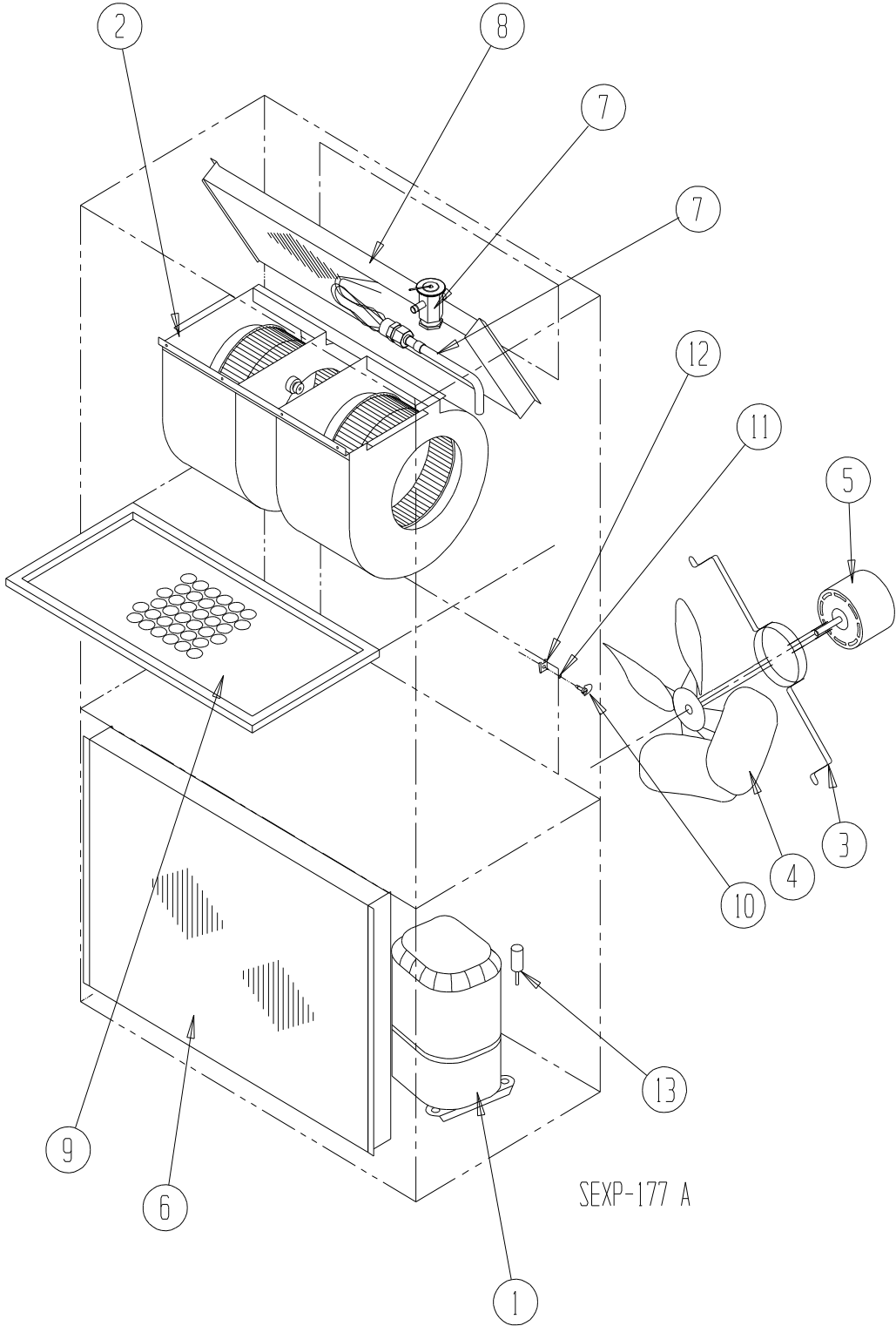

FUNCTIONAL COMPONENTS

Dwg No.	Part Number	Description	H42A2-A	H48A2-A	H60A2-A
1	8000-318	Compressor	X		
1	8000-324	Compressor			X
1	8000-400	Compressor		X	
2	S900-320	Blower Assembly	X	X	
2	S900-185	Blower Assembly			X
3	8200-004	Fan Motor Mount	X	X	X
4	5151-027	Fan Blade	X	X	X
5	8105-039	Condenser Motor	X	X	X
6	5051-179BX	Condenser Coil	X	X	
6	5051-180BX	Condenser Coil			X
7	800-0420	Distributor Assembly	X		
7	800-0422	Distributor Assembly		X	
7	800-0423	Distributor Assembly			X
8	917-0206BX	Evaporator Coil	X		
8	917-0207BX	Evaporator Coil		X	
8	917-0208BX	Evaporator Coil			X
9	7004-027	Air Filter 2" Pleated	X	X	X
10	1171-022	1/4 Turn Fastener	X	X	X
11	1171-024	1/4 Turn Retainer	X	X	X
12	1171-023	1/4 Receptacle	X	X	X
13	1804-0462	High Pressure Switch (Flare)	X	X	X
13	1804-0386	Low Pressure Switch (Flare)	X	X	X
NS	5201-022	Filter Drier	X	X	X
NS	CMA-28	Low Ambient Control (Flare)	X	X	X
NS	5451-024	Tubing Isolation Grommet	2	2	2

NS – Not Shown

CONTROL PANEL

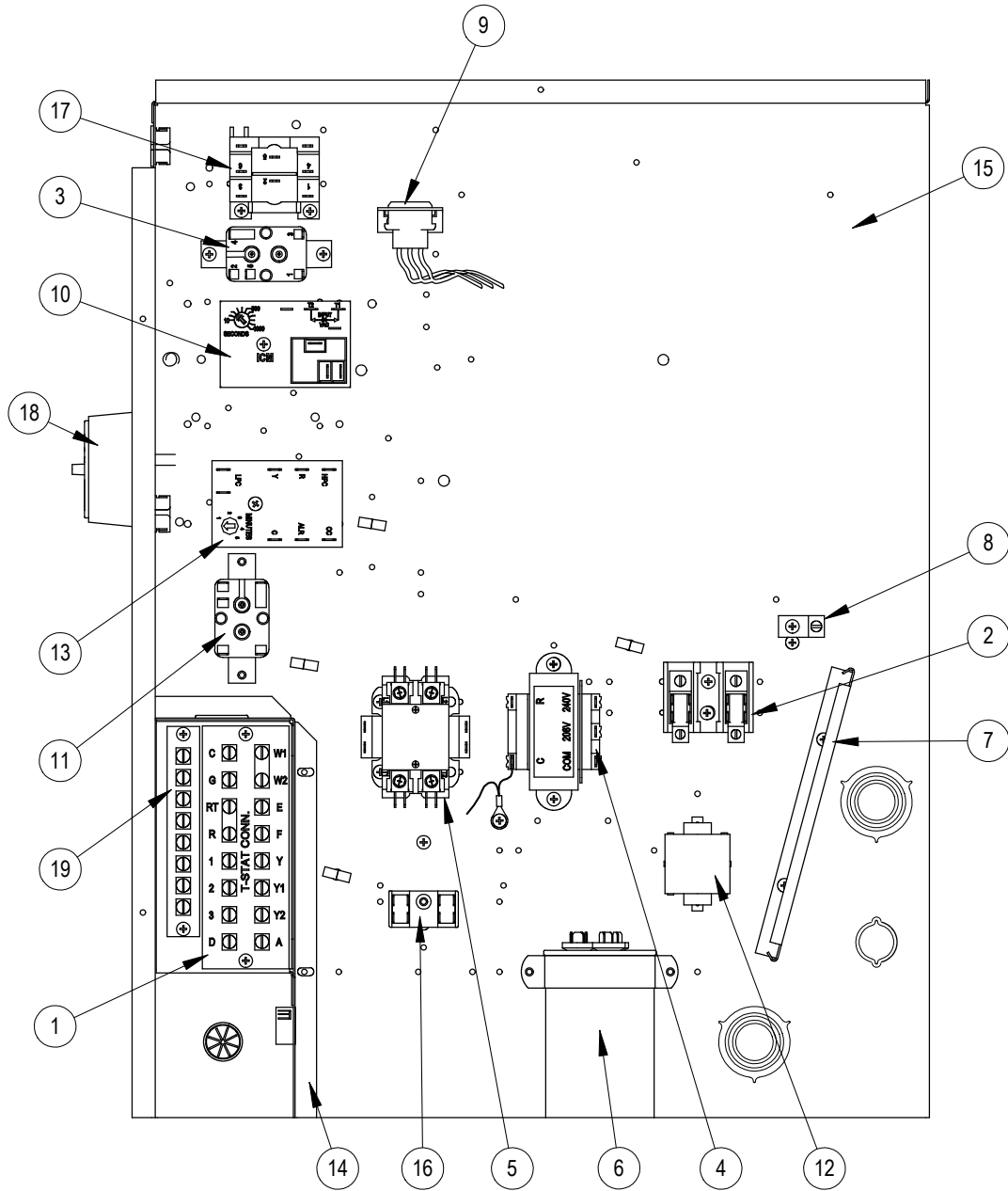

SEXP-670

CONTROL PANEL

Dwg No.	Part Number	Description	H42A2-A	H48A2-A	H60A2-A
1	8607-034	Low Voltage Terminal Strip	X	X	X
2	8607-013	Terminal Block 2 Pole	X	X	X
3	8201-062	Dirty Filter Relay	X	X	X
4	8407-048	Transformer	X	X	X
5	8401-025	Compressor Contactor	X	X	X
6	8552-079	Compressor Capacitor	X		
6	8552-089	Compressor Capacitor		X	
6	8552-058	Compressor Capacitor			X
7	135-130	Wire Shield	X	X	X
8	8611-006	Ground Terminal	X	X	X
9	3000-1277	6 Pin Connector	X	X	X
10	8201-133	Time Delay Relay	X	X	X
11	8201-062	Alarm Relay	X	X	X
12	8551-004	Start Device	X	X	X
13	8201-148	Compressor Control Module	X	X	X
14	117X333	Low Voltage Box	X	X	X
15	117X340	Control Panel	X	X	X
16	8607-017	Terminal Block	X	X	X
17	8201-086	Indoor Blower Relay	X	X	X
18	8301-011	Dirty Filter Switch	X	X	X
19	8607-021	Terminal Strip – 8 Terminal	X	X	X
NS	8615-040	Circuit Breaker 50A 2 Pole ①	X	X	
NS	8615-041	Circuit Breaker 60A 2 Pole ①			X
NS	4095-173	Wiring Diagram	X	X	X
NS	3000-1222	Compressor Plug Wire Assembly	X	X	X
NS	3000-1456	Vent Wire Assembly – 12 Terminal	X	X	X

① Circuit breakers listed are for units without electric heat "0Z" models. See Heater Replacement Parts Manual for units with electric heat.

NS = Not shown

BLOWER ASSEMBLY

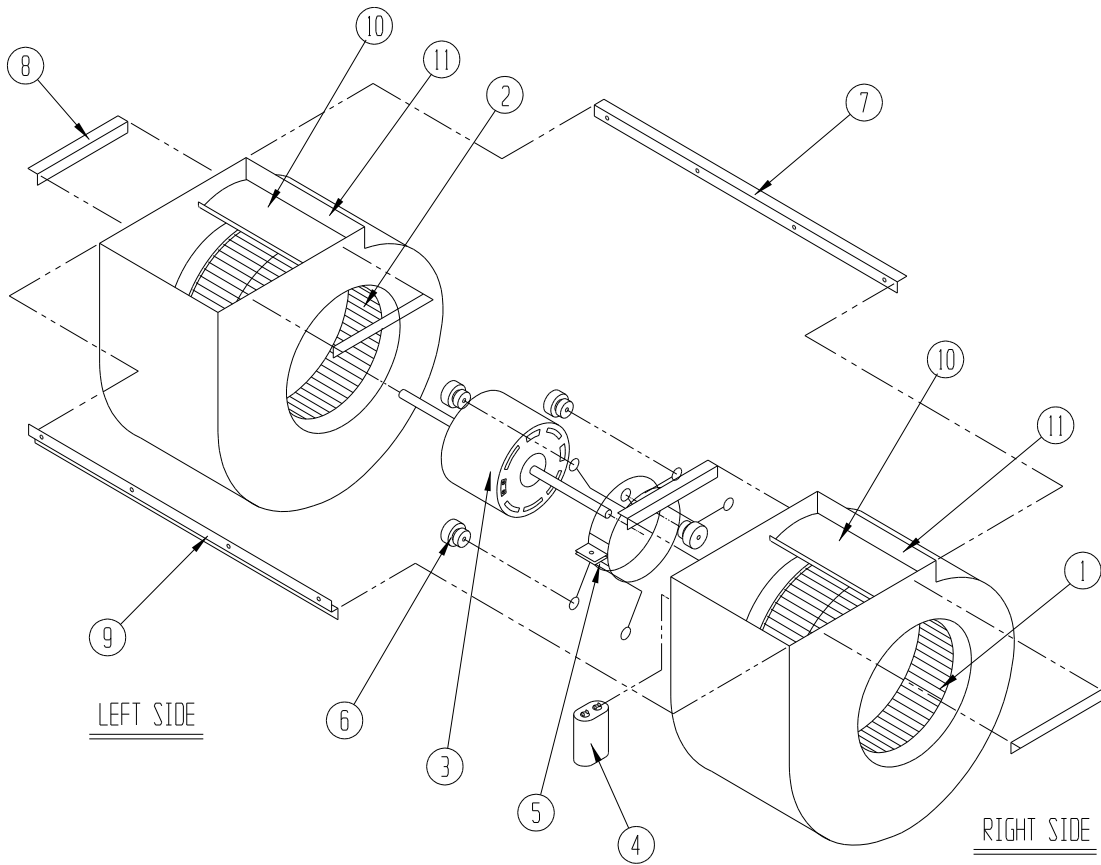

SEXP-178

Dwg No.	Part Number	Description	900-320	900-185
1	5152-011	10 Inch Wheel (CW)		X
1	5152-057	9 Inch Wheel (CW)	X	
2	5152-012	10 Inch Wheel (CW)		X
2	5152-058	9 Inch Wheel (CW)	X	
3	8105-061	Blower Motor (230/208)	X	
3	8106-046	Blower Motor (230/208)		X
4	8552-091	Capacitor	X	
4	8552-005	Capacitor		X
5	8200-040	Motor Mount	X	X
6	5451-011	Grommets	6	6
7	105-881	Back Brace	X	X
8	105-880	Side Angle	4	4
9	103-389	Front Brace	X	X
10	151-101	Housing	2	2
11	144-166	Diffuser	2	2