

---

# REPLACEMENT PARTS MANUAL

---

## WALL MOUNTED PACKAGED AIR CONDITIONER

Models:

H42L2-A H48L2-A H60L2-A

---

### General Notes

- Revised and/or additional pages may be issued from time to time.
- A complete and current manual consists of pages shown in the following contents section.

### Important

- Contact the installing and/or local Bard distributor for all parts requirements. Be sure to have the complete model and serial number available from the unit rating plate.

### Contents

<u>Description</u>	<u>Page</u>
Cabinet Components	
♦ Exploded View .....	2
♦ Usage List .....	3
Functional Components	
♦ Exploded View .....	4
♦ Usage List .....	5
Control Panel	
♦ Layout View .....	6
♦ Usage List .....	7
Blower Assembly	
♦ Exploded View .....	8
♦ Usage List .....	8



Bard Manufacturing Company, Inc.  
Bryan, Ohio 43506  
www.bardhvac.com

Manual: 2110-592E  
Supersedes: 2110-592D  
Date: 7-31-15

# CABINET COMPONENTS

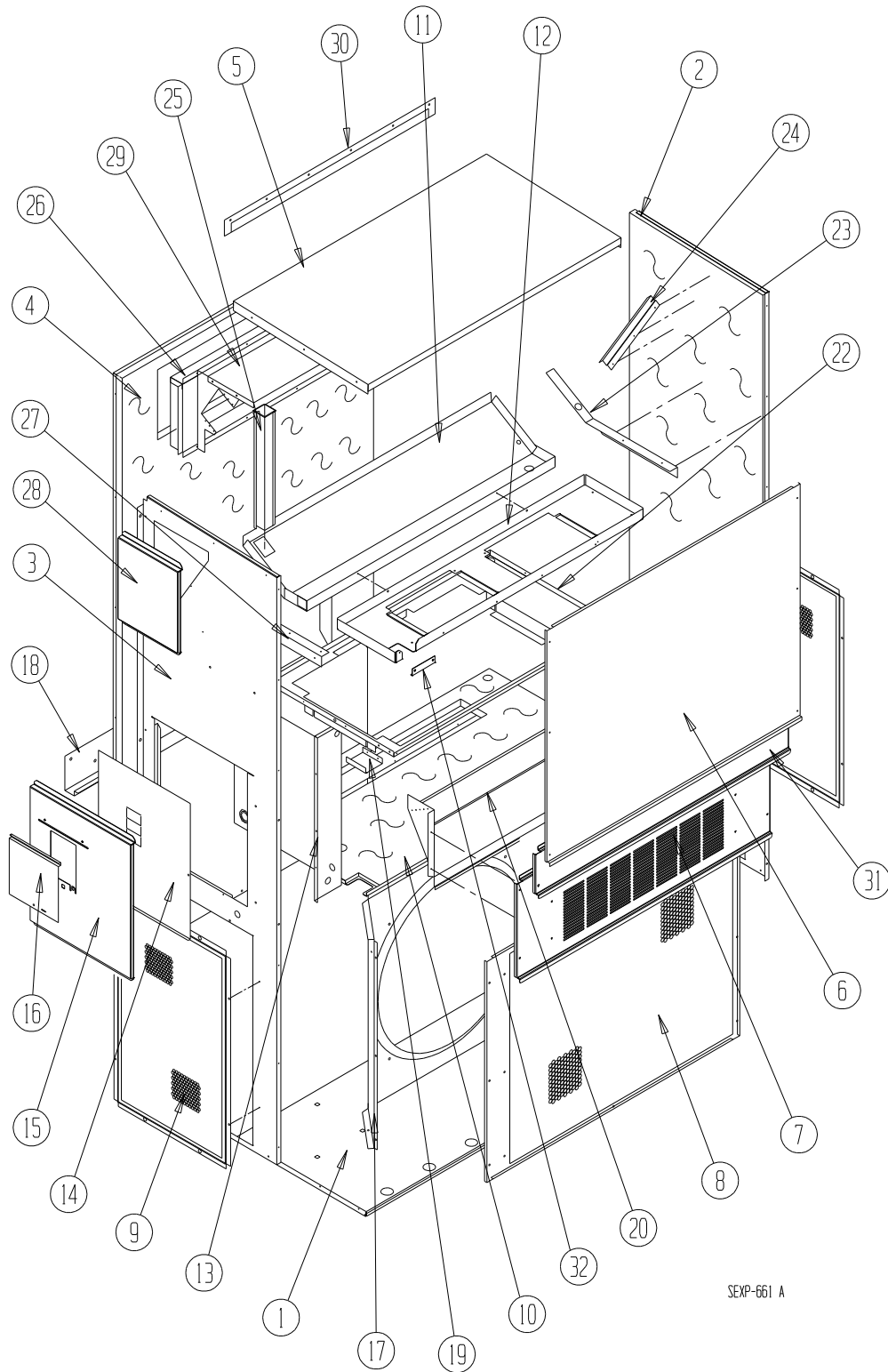

SEXP-661 A

# CABINET COMPONENTS

Dwg No.	Part Number	Description	H42L2-A	H48L2-A	H60L2-A
1	S127-428	Lower Base	X	X	X
1	S127-436 ③	Lower Base	X	X	X
2	S501-687-* ①	Right Side	X	X	X
2	S501-713 ②	Right Side	X	X	X
2	S501-715 ③	Right Side	X	X	X
3	S501-680-* ①	Left Side	X	X	X
3	S501-714 ②	Left Side	X	X	X
3	S501-716 ③	Left Side	X	X	X
4	S508-098	Back	X	X	X
4	S508-275 ②	Back	X	X	X
4	S508-221 ③	Back	X	X	X
5	S507-307-* ①	Top	X	X	X
5	S507-309 ②	Top	X	X	X
5	S507-310 ③	Top	X	X	X
6	S515-230-* ①	Upper Front	X	X	X
6	S514-231 ②	Upper Front	X	X	X
6	S514-232 ③	Upper Front	X	X	X
7	S553-522-* ①	Vent Option Door	X	X	X
7	S553-525 ②	Vent Option Door	X	X	X
7	S553-527 ③	Vent Option Door	X	X	X
8	118-049-* ①	Condenser Grille	X	X	X
8	118-065 ②	Condenser Grille	X	X	X
8	118-074 ③	Condenser Grille	X	X	X
9	118-057-* ①	Side Grille	2	2	2
9	118-063 ②	Side Grille	2	2	2
9	118-073 ③	Side Grille	2	2	2
10	S521Y462	Condenser Partition	X	X	X
11	S123-121	Drain Pan	X	X	X
11	S123-137 ②③	Drain Pan	X	X	X
12	121Y463	Blower Partition	X	X	X
13	Control Panel Assy.	See Control Panel Assy. Drawing & Parts List	X	X	X
14	S133-114	Control Panel Cover (Inner)	X	X	X
15	S533-227-* ①	Control Panel Cover (Outer)	X	X	X
15	S533-231 ②	Control Panel Cover (Outer)	X	X	X
15	S533-233 ③	Control Panel Cover (Outer)	X	X	X
16	S153-218-* ①	Disconnect Access Door	X	X	X
16	S153-387 ②	Disconnect Access Door	X	X	X
16	S153-405 ③	Disconnect Access Door	X	X	X
17	125-024	Fan Shroud	X	X	X
17	125-058 ③	Fan Shroud	X	X	X
18	113-140	Bottom Mounting Bracket	X	X	X
19	137-209	Fill	X	X	X
20	BFAD-5	Fresh Air Damper Assembly	X	X	X
22	S131Y164	Filter Tray	X	X	X
23	105Y878	Left Side Support	X	X	X
24	147-046	Left Evaporator Support	X	X	X
25	135-128	Raceway	2	2	2
26	S111Y034	Outlet Air Frame Assembly	X	X	X
27	105Y877	Right Side Support	X	X	X
28	S543-172-* ①	Right Side Cover Plate (Outer)	X	X	X
28	S543-176 ②	Right Side Cover Plate (Outer)	X	X	X
28	S543-177 ③	Right Side Cover Plate (Outer)	X	X	X
29	135-129	Heat Shield	X	X	X
30	113-150-* ①	Top Rain Flashing	X	X	X
30	113-359 ③	Top Rain Flashing	X	X	X
31	S553-521-* ①	Filter Door Assembly	X	X	X
31	S553-526 ②	Filter Door Assembly	X	X	X
31	S553-528 ③	Filter Door Assembly	X	X	X
32	105-1302	Grommet Retainer	X	X	X
NS	S536-498	Cond. Partition Block Off Plate	X	X	X
NS	105-1324	Close-Off Angle	X	X	X

① Exterior cabinet parts are manufactured with various paint color options. To ensure the proper paint color is received, include the complete model and serial number of the unit for which cabinet parts are being ordered.

② Exterior cabinet parts are manufactured from aluminum Code "A"

③ Exterior cabinet parts are manufactured from stainless steel Code "S"

NS = Not Shown

# FUNCTIONAL COMPONENTS

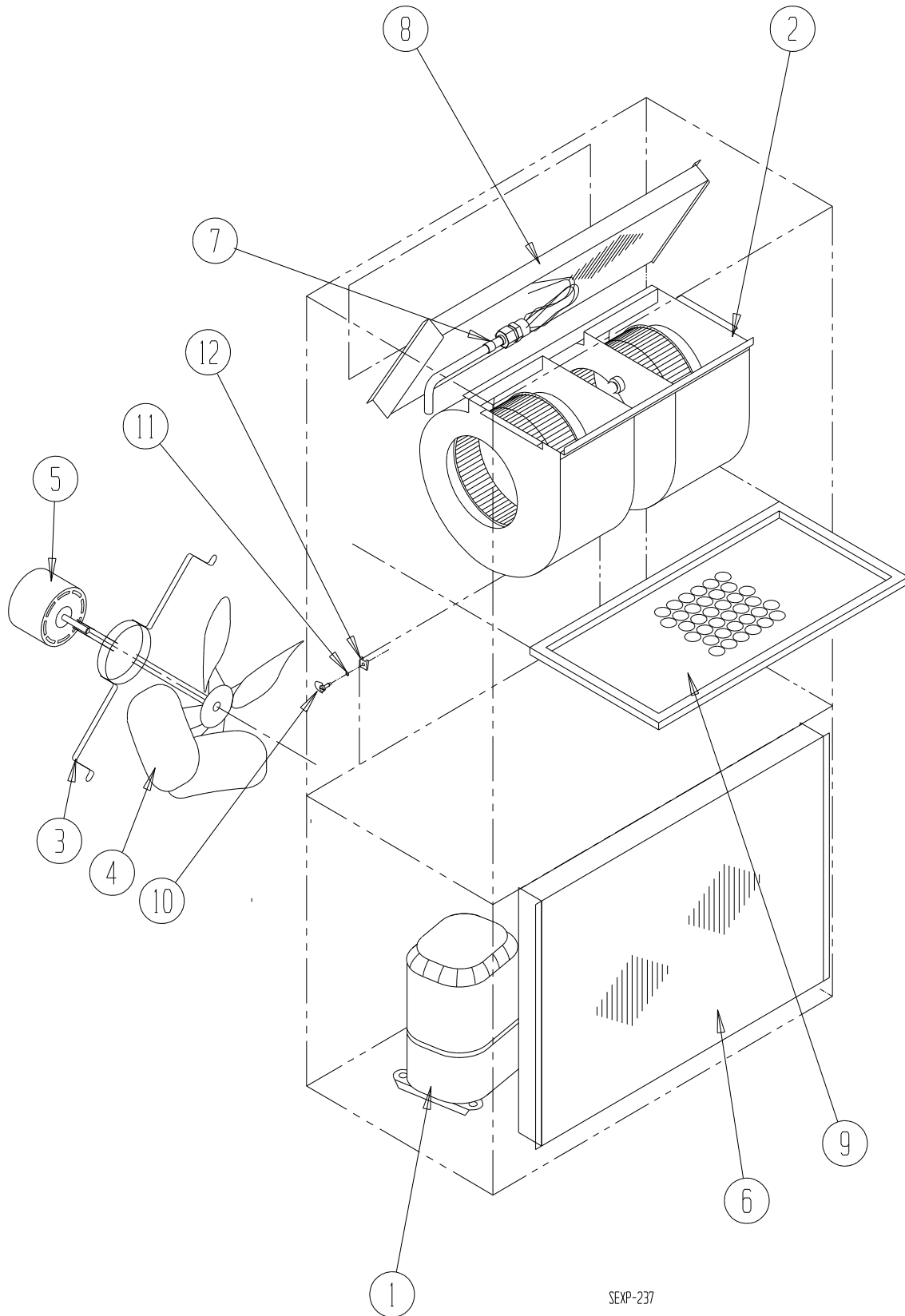

SEXP-237

# FUNCTIONAL COMPONENTS

Dwg No.	Part Number	Description	H42L2-A	H48L2-A	H60L2-A
1	8000-318	Compressor	X		
1	8000-400	Compressor		X	
1	8000-324	Compressor			X
2	S900-320	Blower Assembly	X	X	
2	S900-185	Blower Assembly			X
3	8200-004	Fan Motor Mount	X	X	X
4	5151-060	Fan Blade	X	X	X
5	8105-039	Condenser Motor	X	X	X
6	5051-179BX	Condenser Coil	X	X	
6	5051-180BX	Condenser Coil			X
7	800-0420	Distributor Assembly	X		
7	800-0422	Distributor Assembly		X	
7	800-0423	Distributor Assembly			X
8	917-0207BX	Evaporator Coil		X	
8	917-0208BX	Evaporator Coil			X
8	917-0206BX	Evaporator Coil	X		
9	7004-027	Air Filter 2" Pleated	X	X	X
10	1171-022	1/4 Turn Fastener	X	X	X
11	1171-024	1/4 Turn Retainer	X	X	X
12	1171-023	1/4 Receptacle	X	X	X
NS	5201-022	Filter Drier	X	X	X
NS	CMA-28	Low Ambient Control	X	X	X
NS	1804-0462	High Pressure Switch (Flare)	X	X	X
NS	1804-0386	Low Pressure Switch (Flare)	X	X	X
NS	5451-024	Tubing Isolation Grommet	2	2	2

NS = Not Shown



# CONTROL PANEL

Dwg No.	Part Number	Description	H42L2-A	H48L2-A	H60L2-A
1	8607-034	Low Voltage Terminal Strip	X	X	X
2	8607-013	Terminal Block 2 Pole	X	X	X
3	8201-062	Dirty Filter Relay	X	X	X
4	8407-048	Transformer	X	X	X
5	8401-025	Compressor Contactor	X	X	X
6	8552-079	Compressor Capacitor	X		
6	8552-089	Compressor Capacitor		X	
6	8552-058	Compressor Capacitor			X
7	135-130	Wire Shield	X	X	X
8	8611-006	Ground Terminal	X	X	X
9	3000-1277	6 Pin Connector	X	X	X
10	8201-133	Time Delay Relay	X	X	X
11	8201-062	Alarm Relay	X	X	X
12	8551-004	Start Device	X	X	X
13	8201-148	Compressor Control Module	X	X	X
14	117Y333	Low Voltage Box	X	X	X
15	117Y340	Control Panel	X	X	X
16	8607-017	Terminal Block	X	X	X
17	8201-086	Indoor Blower Relay	X	X	X
18	8301-011	Dirty Filter Switch	X	X	X
19	8607-021	Terminal Strip – 8 Terminal	X	X	X
NS	8615-040	Circuit Breaker 50A 2 Pole ①	X	X	
NS	8615-041	Circuit Breaker 60A 2 Pole ①			X
NS	4095-173	Wiring Diagram	X	X	X
NS	3000-1222	Compressor Plug Wire Assembly	X	X	X
NS	3000-1456	Vent Wire Assembly – 12 Terminal	X	X	X

① Circuit breakers listed are for units without electric heat "OZ" models. See Heater Replacement Parts Manual for units with electric heat.

NS = Not Shown

# BLOWER ASSEMBLY

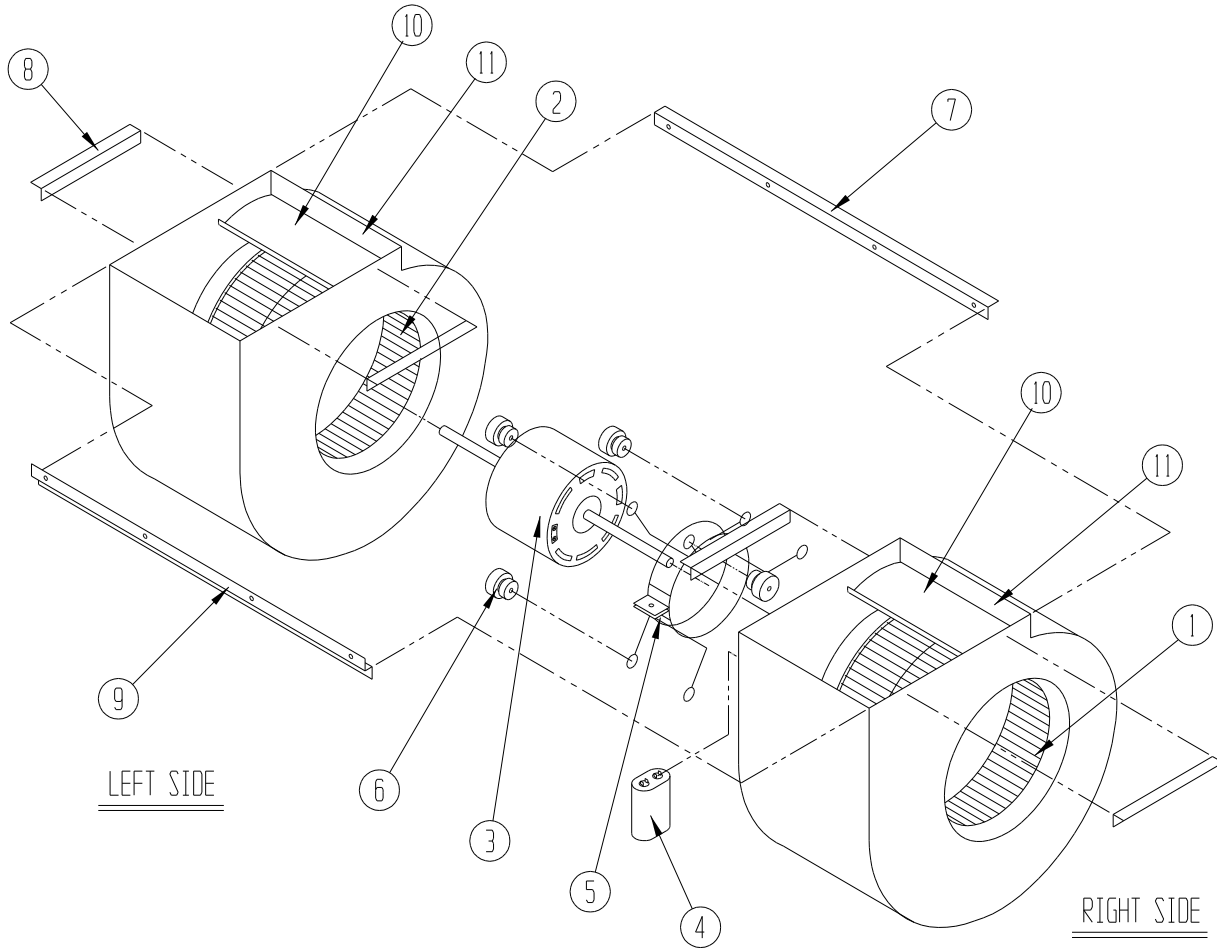

SEXP-178

Dwg No.	Part Number	Description	900-320	900-185
1	5152-011	10 Inch Wheel (CW)		X
1	5152-057	9 Inch Wheel (CW)	X	
2	5152-012	10 Inch Wheel (CW)		X
2	5152-058	9 Inch Wheel (CW)	X	
3	8105-061	Blower Motor (230/208)	X	
3	8106-046	Blower Motor (230/208)		X
4	8552-091	Capacitor	X	
4	8552-005	Capacitor		X
5	8200-040	Motor Mount	X	X
6	5451-011	Grommets	6	6
7	105-881	Back Brace	X	X
8	105-880	Side Angle	4	4
9	103-389	Front Brace	X	X
10	151-101	Housing	2	2
11	144-166	Diffuser	2	2