

REPLACEMENT PARTS MANUAL

I-TEC® SERIES PACKAGED AIR CONDITIONER

Models:

I30A1DA	I36A1DA	I42A1DA	I48A1DA	I60A1DA
I30A1DB	I36A1DB	I42A1DB	I48A1DB	I60A1DB
I30A1DC	I36A1DC	I42A1DC	I48A1DC	I60A1DC

Description	Page	Description	Page
Wiring Diagram Charts		Modulating CRV Control Panel Components	
♦ Matrix	2	♦ Exploded View	28
Cabinet Components		♦ Usage List	29
♦ Exploded View	4	ERV Components	
♦ Usage List	5	♦ Exploded View	30
Painted Cabinet Components		♦ Usage List	31
♦ Exploded View	6	ERV Control Panel Components	
♦ Usage List	7	♦ Exploded View	32
Functional Components		♦ Usage List	33
♦ Exploded View	8	ERV Cassette Components	
♦ Usage List	9	♦ Exploded View	34
♦ Usage List	10	♦ Usage List	35
Blower Assembly		CRV/ERV Blower Components	
♦ Exploded View	11	♦ Exploded View	36
♦ Usage List	11	♦ Usage List	37
Control Panel Components - 1 Phase		Sleeve Components	
♦ Exploded View	12	♦ Exploded View	38
♦ Usage List	13	♦ Usage List	39
Control Panel Components - 3 Phase		Riser Platform Components	
♦ Exploded View	14	♦ Exploded View	40
♦ Usage List	15	♦ Usage List	41
Control Panel Components - 460V 3 Phase			
♦ Exploded View	16		
♦ Usage List	17		
Electric Heater Components			
♦ Exploded View	18		
♦ Usage List	19		
♦ Usage List	20		
♦ Usage List	21		
Vent Box (Only) Components			
♦ Exploded View	22		
♦ Usage List	23		
CRV Components			
♦ Exploded View	24		
♦ Usage List	25		
Modulating CRV Components			
♦ Exploded View	26		
♦ Usage List	27		

General Notes

- Revised and/or additional pages may be issued from time to time.
- A complete and current manual consists of pages shown in the following contents section.

Important

- Contact the installing and/or local Bard distributor for all parts requirements. Be sure to have the complete model and serial number available from the unit rating plates.



Bard Manufacturing Company, Inc.
 Bryan, Ohio 43506
 www.bardhvac.com

Manual: 2110-593L
 Supersedes: 2110-593K
 Date: 11-4-16

I**A1D SERIES WIRING DIAGRAM MATRIX

Model	Wiring Diagram	Ventilation Package	Wiring Diagram	Heater	Wiring Diagram
I30A1DA	4205-100F	Commercial Room Ventilator	4204-103A	0KW	4203-100B
		Energy Recovery Ventilator	4204-104B	5KW	4203-101B
		Economizer	4204-105	10KW	4203-106
		Modulating Commercial Room Ventilator	4204-106		
I30A1DB	4205-200F	Commercial Room Ventilator	4204-103A	0KW	4203-200B
		Energy Recovery Ventilator	4204-104B	6KW	4203-201C
		Economizer	4204-105	9KW	4203-201C
		Modulating Commercial Room Ventilator	4204-106		
I30A1DC	4205-300G	Commercial Room Ventilator	4204-103A	0KW	4203-300C
		Energy Recovery Ventilator	4204-104B	6KW	4203-301D
		Economizer	4204-105	9KW	4203-301D
		Modulating Commercial Room Ventilator	4204-106	15KW	4203-302D
I36A1DA	4205-100F	Commercial Room Ventilator	4204-103A	0KW	4203-100B
		Energy Recovery Ventilator	4204-104B	5KW	4203-101B
		Economizer	4204-105	10KW	4203-106
		Modulating Commercial Room Ventilator	4204-106	15KW	4203-104B
I36A1DB	4205-200F	Commercial Room Ventilator	4204-103A	0KW	4203-200B
		Energy Recovery Ventilator	4204-104B	6KW	4203-201C
		Economizer	4204-105	9KW	4203-201C
		Modulating Commercial Room Ventilator	4204-106	15KW	4203-202B
I36A1DC	4205-300G	Commercial Room Ventilator	4204-103A	0KW	4203-300C
		Energy Recovery Ventilator	4204-104B	6KW	4203-301D
		Economizer	4204-105	9KW	4203-301D
		Modulating Commercial Room Ventilator	4204-106	15KW	4203-302D
I42A1DA	4205-100F	Commercial Room Ventilator	4204-103A	0KW	4203-100B
		Energy Recovery Ventilator	4204-104B	5KW	4203-101B
		Economizer	4204-105	10KW	4203-106
		Modulating Commercial Room Ventilator	4204-106	15KW	4203-104B
I42A1DB	4205-200F	Commercial Room Ventilator	4204-103A	0KW	4203-200B
		Energy Recovery Ventilator	4204-104B	6KW	4203-201C
		Economizer	4204-105	9KW	4203-201C
		Modulating Commercial Room Ventilator	4204-106	15KW	4203-202B
I42A1DC	4205-300G	Commercial Room Ventilator	4204-103A	0KW	4203-300C
		Energy Recovery Ventilator	4204-104B	6KW	4203-301D
		Economizer	4204-105	9KW	4203-301D
		Modulating Commercial Room Ventilator	4204-106	15KW	4203-302D
I48A1DA	4205-100F	Commercial Room Ventilator	4204-103A	0KW	4203-100B
		Energy Recovery Ventilator	4204-104B	4KW	4203-101B
		Economizer	4204-105	5KW	4203-102B
		Modulating Commercial Room Ventilator	4204-106	10KW	4203-106
				15KW	4203-104B
				20KW	4203-105B
I48A1DB	4205-200F	Commercial Room Ventilator	4204-103A	0KW	4203-200B
		Energy Recovery Ventilator	4204-104B	6KW	4203-201C
		Economizer	4204-105	9KW	4203-201C
		Modulating Commercial Room Ventilator	4204-106	15KW	4203-202B
I48A1DC	4205-300G	Commercial Room Ventilator	4204-103A	0KW	4203-300C
		Energy Recovery Ventilator	4204-104B	6KW	4203-301D
		Economizer	4204-105	9KW	4203-301D
		Modulating Commercial Room Ventilator	4204-106	15KW	4203-302D
I60A1DA	4205-100F	Commercial Room Ventilator	4204-103A	0KW	4203-100B
		Energy Recovery Ventilator	4204-104B	4KW	4203-101B
		Economizer	4204-105	5KW	4203-102B
		Modulating Commercial Room Ventilator	4204-106	10KW	4203-106
				15KW	4203-104B
				20KW	4203-105B
I60A1DB	4205-200F	Commercial Room Ventilator	4204-103A	0KW	4203-200B
		Energy Recovery Ventilator	4204-104B	6KW	4203-201C
		Economizer	4204-105	9KW	4203-201C
		Modulating Commercial Room Ventilator	4204-106	15KW	4203-202B
				18KW	4203-202B
I60A1DC	4205-300G	Commercial Room Ventilator	4204-103A	0KW	4203-300C
		Energy Recovery Ventilator	4204-104B	6KW	4203-301D
		Economizer	4204-105	9KW	4203-301D
		Modulating Commercial Room Ventilator	4204-106	15KW	4203-302D
				18KW	4203-302D

This page intentionally left blank

CABINET COMPONENTS

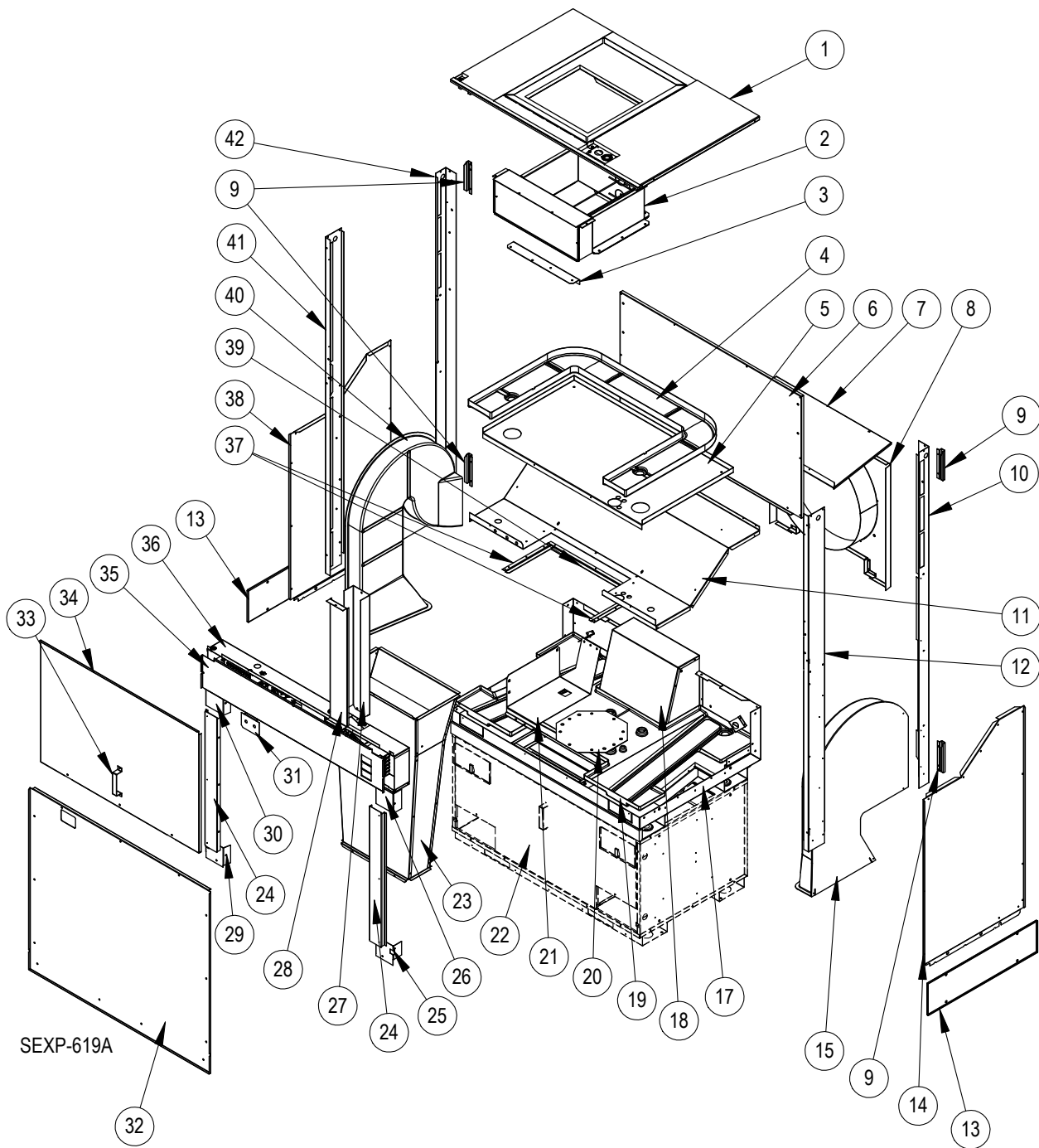

CABINET COMPONENTS

Drawing No.	Part Number	Description	All Models
1	S507-296	Top Assembly	X
2	See Heater Pkg. Section	Heater Package	X
3	105-1256	Front blower angle	X
4	6096-001	Indoor drain pan	X
5	S141-383	Evap. Coil Support	X
6	509-259-8	Unit Back Assembly	X
7	S137-641	Cond. Coil Top Fill	X
8	S125-065	Fan Shroud/Venturi Assembly	X
9	113-439	Side Bracket	4
10	S149-120	Right Rear Corner	X
11	S121-456	Condenser Partition	X
12	S149-123	Right Front Corner	X
13	113-630	Unit Connection Bracket	2
14	S101X635	Right Inner Side Panel	X
15	7001-026	Right Hand Inlet Duct (used on CRV & ERV units only)	X
17	S127-522	Condenser Base Assembly	X
18	S921-0003	Exhaust Duct Assembly	X
19	6096-009	Outdoor Drain Pan	X
20	126-417	Compressor Mounting Base	X
21	113-595	460V trans. Mtg brkt. (I36-42-48)	X
	113-449	460V trans. Mtg brkt. (I60 Only)	X
22	See Vent Section	Vent Option	X
23	511-177	Intake Duct Assembly (used on CRV and ERV units only)	X
24	S141-391	Condenser Coil Access Door	X
25	S141X390	Lower Right Condenser Coil Support	X
26	S141X389	Upper Right Condenser Coil Support	X
27	165-603	High Voltage Wire Channel	X
28	143-202	High Voltage Wire Channel Cover	X
29	S141Y390	Lower Left Condenser Coil Support	X
30	S141Y389	Upper Left Condenser Coil Support	X
31	S113-440	Dual Service Port Bracket	X
32	S553-498	Condenser Door	X
33	113-441	Door Latch Bracket	X
34	S553-496	Evaporator Door	X
35	S153-497	Control Panel Door (230V Units)	X
	S153-501	Control Panel Door (460V Units)	X
36	See Control Panel Section	Control Panel	X
37	103-493	Cond. Partition Side Offset	2
38	S101Y635	Left Inner Side Panel	X
39	103-494	Cond. Partition Rear Offset	X
40	7001-027	Left Hand Inlet Duct (used on CRV & ERV units only)	X
41	S149-121	Left Front Corner	X
42	S149-122	Left Rear Corner	X
NS	S113-426	Top Mounting Bracket	X

NS = Not Shown

PAINTED CABINET COMPONENTS

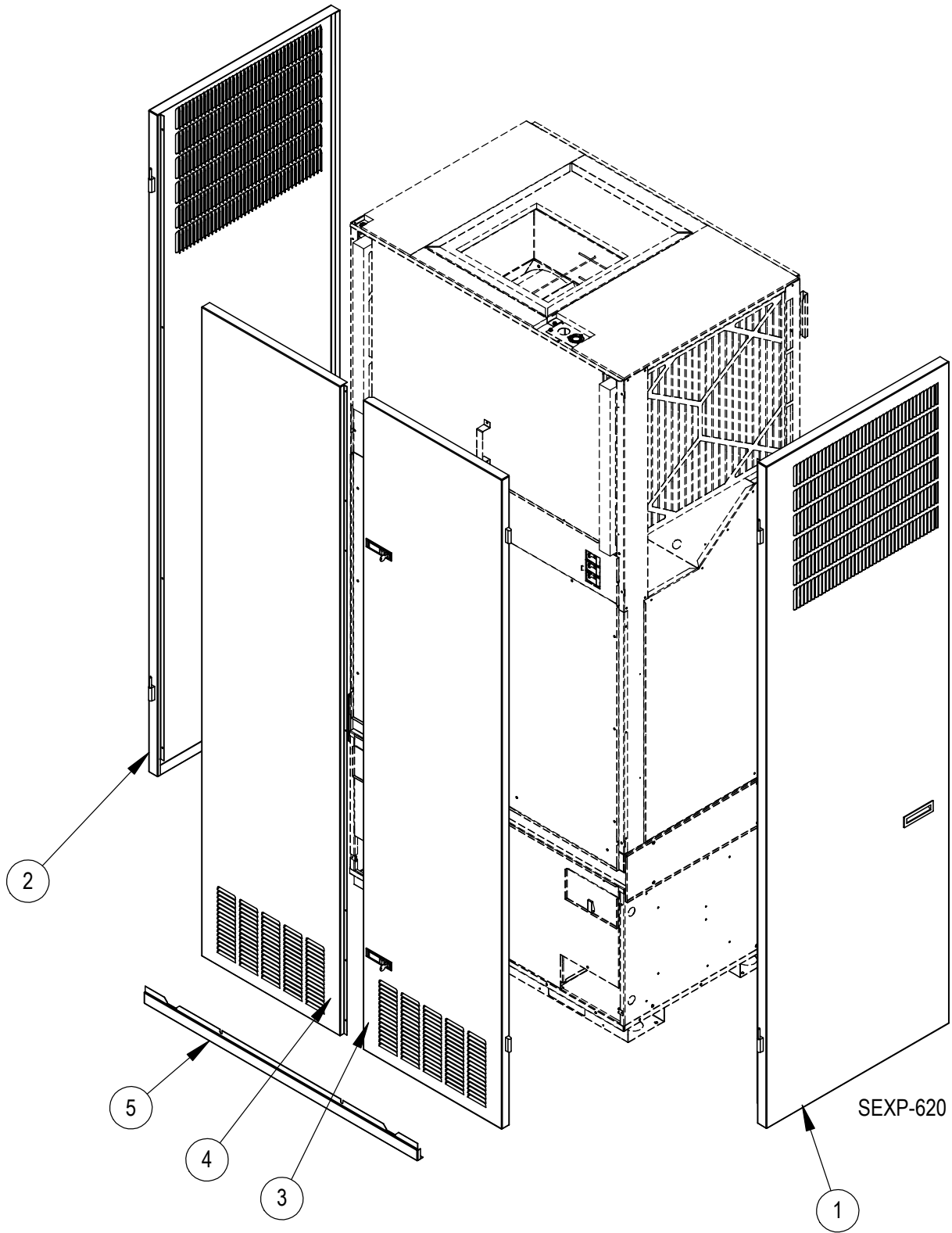

PAINTED CABINET COMPONENTS

Drawing No.	Part Number	Description	All Models
1	501-636-*	Right Side	X
2	501-637-*	Left Side	X
3	S553-500-*	Right Front Door	X
4	S553-499-*	Left Front Door	X
5	115-206-*	Front Unit Trim	X

* Exterior cabinet parts are manufactured with various paint color options. To ensure the proper paint color is received, reference the following codes:

- Beige -X
- White -1
- Buckeye Gray -4

FUNCTIONAL COMPONENTS

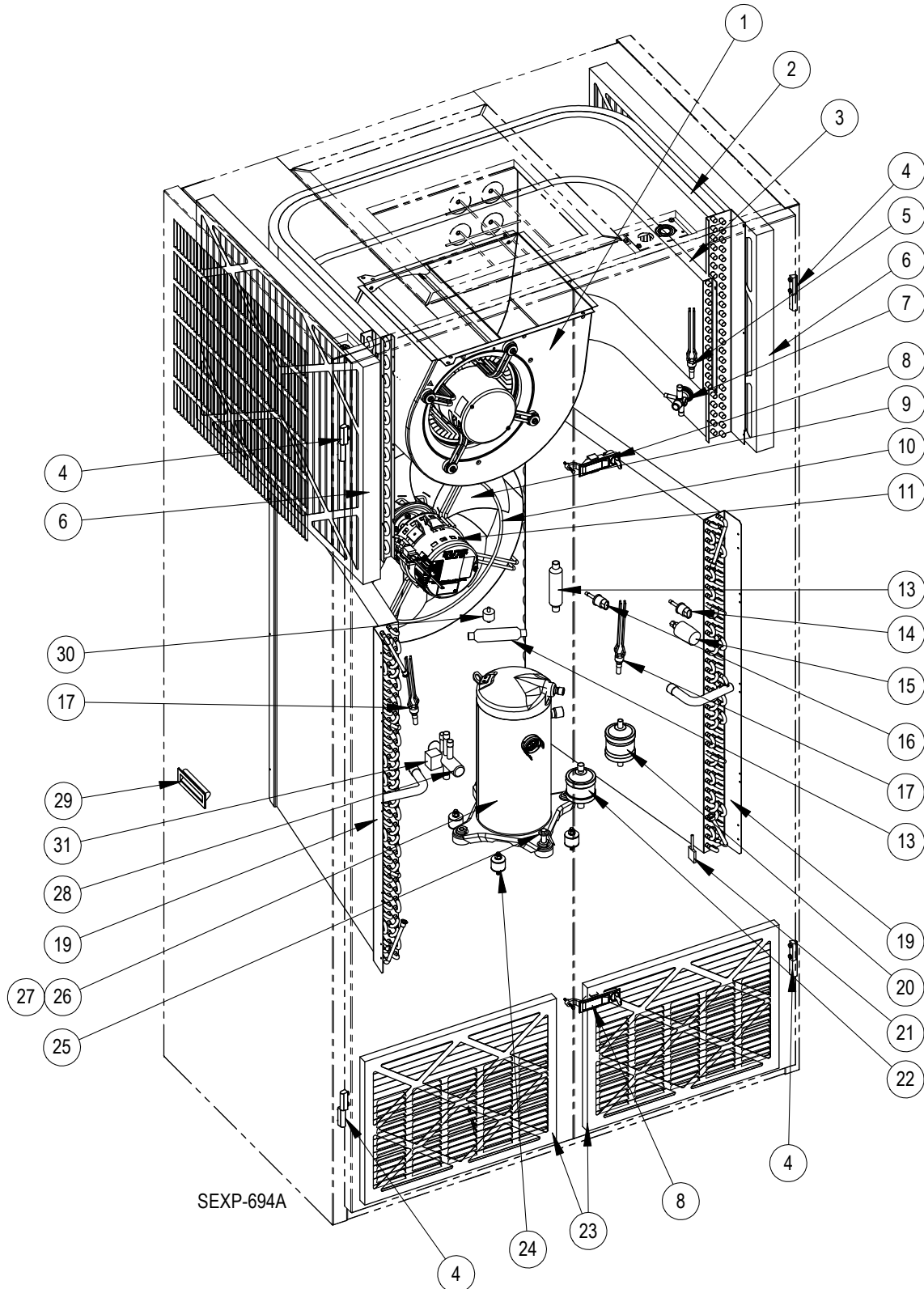

FUNCTIONAL COMPONENTS

Drawing No.	Part Number	Description	I30A1DA	I30A1DB	I30A1DC	I36A1DA	I36A1DB	I36A1DC	I42A1DA	I42A1DB	I42A1DC	I48A1DA	I48A1DB	I48A1DC	I60A1DA	I60A1DB	I60A1DC
1	S5154-002-0090	Complete Blower Assembly See Blower section for individual components	X	X	X												
	S5154-005-0089					X	X	X									
	S5154-005-0088								X	X	X						
	S5154-005-0087											X	X	X			
	S5154-006-0081															X	X
2	5060-174BX	Evaporator Coil	X	X	X												
	5060-168BX					X	X	X	X	X	X	X	X	X			
	5060-175BX															X	X
3	5051-173BX	Dehumidification Reheat Coil	X	X	X												
	5051-174BX					X	X	X	X	X	X						
	5051-175BX											X	X	X	X	X	X
4	5400-006	Polymide Lift-Off Hinge	4	4	4	4	4	4	4	4	4	4	4	4	4	4	
5	5625-014	Distributor	X	X	X												
	5625-007					X	X	X	X	X	X	X	X	X			
	5625-008															X	X
6	7004-050	MERV 8 Filter MERV 11 Filter MERV 13 Filter	2	2	2	2	2	2	2	2	2	2	2	2	2	2	2
	7004-051																
	7004-053																
7	5651-210	Expansion Valve	X	X	X												
	5651-212											X	X	X			
	5651-211					X	X	X	X	X	X						
	5651-241															X	X
8	1171-063	Lockable Latch	2	2	2	2	2	2	2	2	2	2	2	2	2	2	
9	5151-058	Fan Blade	X	X	X	X	X	X	X	X	X	X	X	X	X	X	
10	8200-045	Fan Mount	X	X	X	X	X	X	X	X	X	X	X	X	X	X	
11	S8105-058-0109	Programmed Outdoor Motor	X	X	X												
	S8105-058-0095					X	X	X	X	X	X						
	S8106-054-0096											X	X	X	X	X	X
13	5651-219	Check Valve	2	2	2	2	2	2	2	2	2	2	2	2	2	2	
14	8406-142	High Pressure Switch, 650 PSIG	X	X	X	X	X	X	X	X	X	X	X	X	X	X	
15	8406-112	Low Ambient Control	X	X	X	X	X	X	X	X	X	X	X	X	X	X	
16	8406-140	Low Pressure Switch	X	X	X	X	X	X	X	X	X	X	X	X	X	X	
17	5625-013	Distributor	2	2	2	2	2	2	2	2							
	5625-007											2	2	2	2	2	2
19	5051-190BX	Condenser Coil	2	2	2												
	5051-189BX					2	2	2	2	2	2						
	5051-191BX											2	2	2	2	2	2
20	5201-022	Filter-Drier	X	X	X	X	X	X	X	X	X	X	X	X	X	X	

FUNCTIONAL COMPONENTS

Drawing No.	Part Number	Description	I30A1DA	I30A1DB	I30A1DC	I36A1DA	I36A1DB	I36A1DC	I42A1DA	I42A1DB	I42A1DC	I48A1DA	I48A1DB	I48A1DC	I60A1DA	I60A1DB	I60A1DC	
22	5220-013	Pulsation Dampener/Muffler	X	X	X	X	X	X	X	X	X	X	X	X	X	X	X	
23	7004-003	Filter	2	2	2	2	2	2	2	2	2	2	2	2	2	2	2	
24	8001-013	Compressor Grommet	4	4	4	4	4	4	4	4	4	4	4	4	4	4	4	
25	1012-328	Compressor Bolt	4	4	4	4	4	4	4	4	4	4	4	4	4	4	4	
26	8000-388	Compressor	X															
	8000-389			X														
	8000-390				X													
	8000-379					X												
	8000-380						X											
	8000-381							X										
	8000-391								X									
	8000-392									X								
	8000-393										X							
	8000-382											X						
	8000-383												X					
	8000-384													X				
	8000-385														X			
8000-386														X				
8000-387															X			
27	8002-012	Compressor Sound Cover	X	X	X	X	X	X	X	X	X							
	8002-013											X	X	X	X	X	X	
28	5650-051	Dehum. Valve, 4-Pipe	X	X	X	X	X	X	X	X	X	X	X	X	X	X	X	
29	1171-060	Flush Plastic Door Pull	2	2	2	2	2	2	2	2	2	2	2	2	2	2	2	
30	5451-018	Motor Mount Grommet	2	2	2	2	2	2	2	2	2	2	2	2	2	2	2	
NS	6094-011	3/4" Barbed Drain Pan Fitting	4	4	4	4	4	4	4	4	4	4	4	4	4	4	4	
NS	6001-016	Nylon Barbed Tee	X	X	X	X	X	X	X	X	X	X	X	X	X	X	X	
NS	7950-021	1" Hose Clamp	8	8	8	8	8	8	8	8	8	8	8	8	8	8	8	
NS	910-1977	Evap. Overflow Switch Ass'y	X	X	X	X	X	X	X	X	X	X	X	X	X	X	X	
NS	6031-009	Coremax Valve Core	X	X	X	X	X	X	X	X	X	X	X	X	X	X	X	

NS = Not Shown

BLOWER ASSEMBLY COMPONENTS

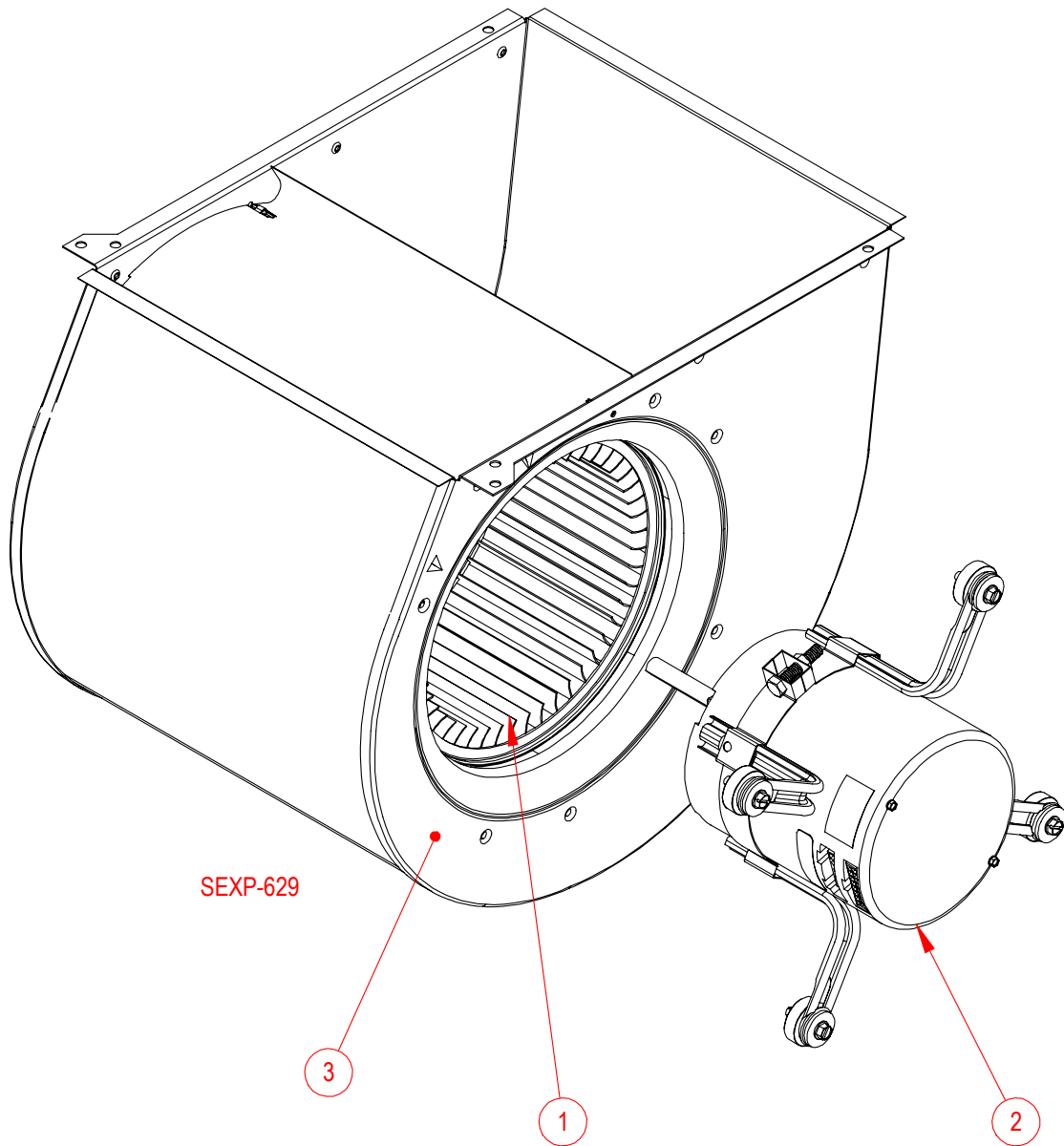

Drawing No.	Part Number	Description	5154-002-0090	5154-005-0089	5154-005-0088	5154-005-0087	5154-006-0081
1	5152-049	Blower Wheel	X	X	X	X	X
2	S8105-059-0090	1/3 HP Programmed Motor	X				
	S8106-051-0089	3/4 HP Programmed Motor		X			
	S8106-051-0088	3/4 HP Programmed Motor			X		
	S8106-051-0087	3/4 HP Programmed Motor				X	
	S8107-016-0081	1 HP Programmed Motor					X
3	151-122	Housing	X	X	X	X	X

CONTROL PANEL COMPONENTS - 1 PHASE

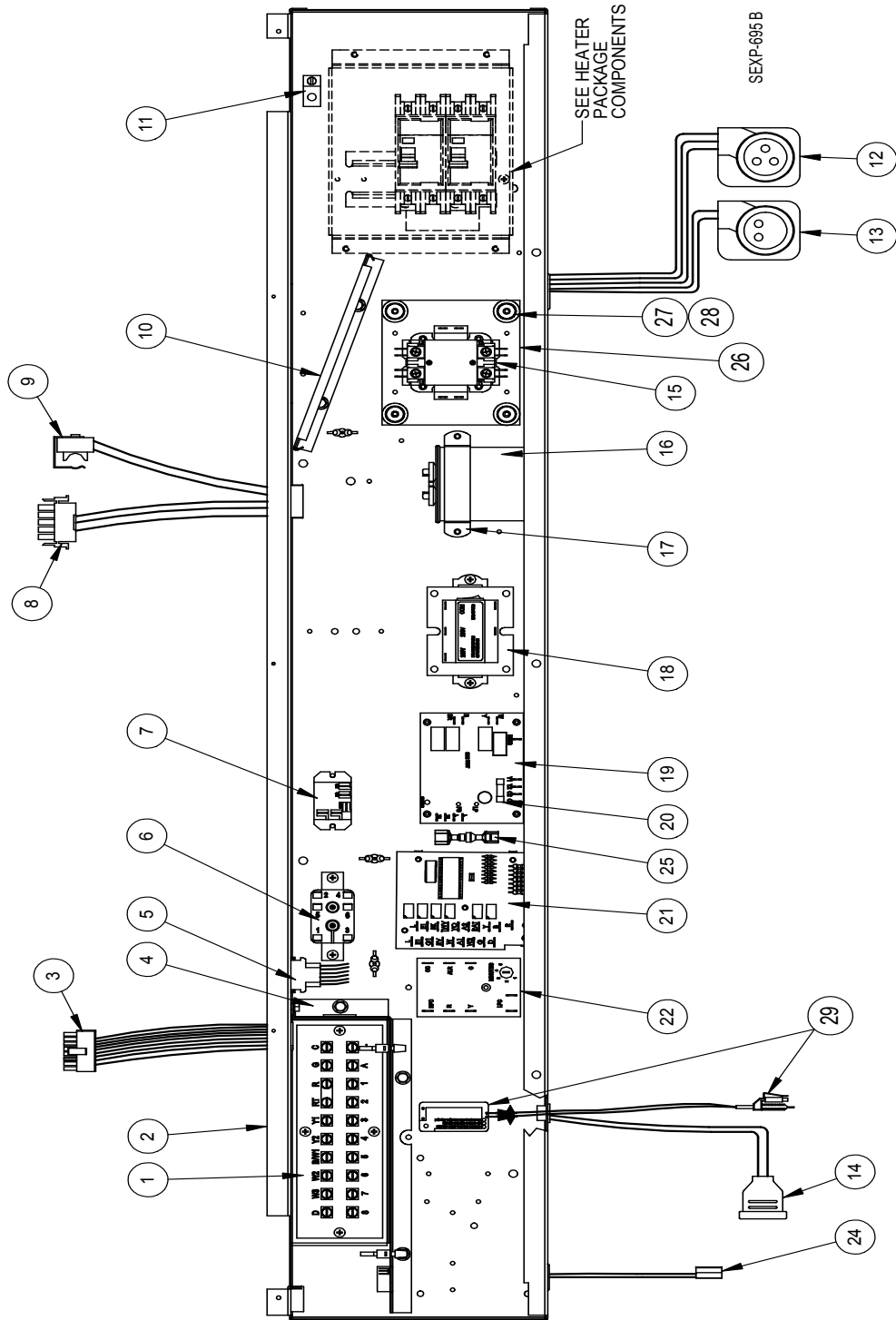

CONTROL PANEL COMPONENTS – 1 PHASE

Drawing No.	Part Number	Description	I30A1DA	I36A1DA	I42A1DA	I48A1DA	I60A1DA
1	8607-032	Low Voltage Terminal Strip	X	X	X	X	X
2	517-391	Control Panel	X	X	X	X	X
3	3000-1396	16 pin 24V Indoor Blower Motor Control	X	X	X	X	X
4	117-319	Low Voltage terminal box	X	X	X	X	X
5	3000-1397	6 Pin Elect. Heat	X	X	X	X	X
6	8201-062	Relay	X	X	X	X	X
7	8201-130	Relay	X	X	X	X	X
8	3000-1398	5 Pin Indoor Blower Motor Power	X	X	X	X	X
9	8408-048	Freeze protect thermostat	X	X	X	X	X
10	135-319	Wire Shield	X	X	X	X	X
11	8611-006	Ground Terminal	X	X	X	X	X
12	3000-1222	Compressor Power Plug	X	X	X	X	X
13	3000-1223	Compressor Solenoid Plug	X	X	X	X	X
14	5650-044	Solenoid Valve plug	X	X	X	X	X
15	8401-025	Contacto 2 Pole 40 Amp	X	X	X	X	X
16	8552-035	Capacitor 40MFD 370V	X	X			
	8552-043	Capacitor 45MFD 370V			X		
	8552-095	Capacitor 30MFD 370V				X	
	8552-096	Capacitor 40MFD 440V					X
17	8550-007	Capacitor Bracket 2" Round	X	X			X
	8550-008	Capacitor Bracket 2-1/2" Round			X		
	8550-006	Capacitor Bracket 1-3/4" Round				X	
18	8407-048	Transformer 75VA with Circuit Breaker	X	X	X	X	X
19	8201-128	Fan Logic Control	X	X	X	X	X
20	8614-052	3.15 Amp Fuse	X	X	X	X	X
21	8201-113	Dehum Logic Board	X	X	X	X	X
22	8201-088	Compressor Control Module	X	X	X	X	X
24	8408-043	Fan Control Thermistor	X	X	X	X	X
25	910-1816	Fan Control Resistor (Optional)	X	X	X	X	X
26	116-332	Contacto Isolation Plate	X	X	X	X	X
27	5451-025	Rubber Grommet	X	X	X	X	X
28	5451-026	Nylon Flanged Bushing	X	X	X	X	X
29	910-1914	Overflow Switch Assembly	X	X	X	X	X

CONTROL PANEL COMPONENTS - 3 PHASE

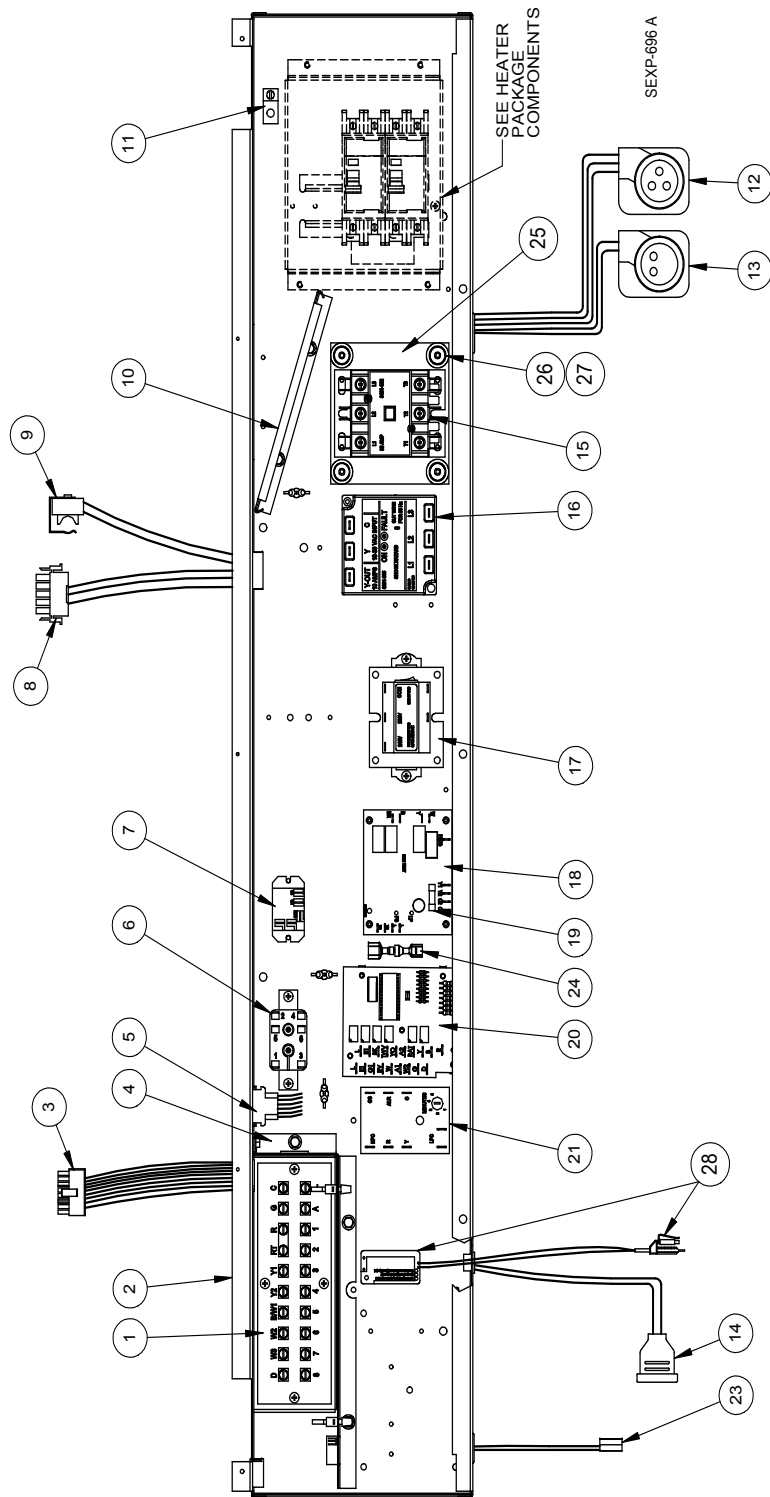

CONTROL PANEL COMPONENTS – 3 PHASE

Drawing No.	Part Number	Description	I30A1DB	I36A1DB	I42A1DB	I48A1DB	I60A1DB
1	8607-032	Low Voltage Terminal Strip	X	X	X	X	X
2	517-391	Control Panel	X	X	X	X	X
3	3000-1396	16 pin 24V Indoor Blower Motor Control	X	X	X	X	X
4	117-319	Low Voltage Terminal Box	X	X	X	X	X
5	3000-1397	6 Pin Elect. Heat	X	X	X	X	X
6	8201-062	Relay	X	X	X	X	X
7	8201-130	Relay	X	X	X	X	X
8	3000-1398	5 Pin Indoor Blower Motor Power	X	X	X	X	X
9	8408-048	Freeze Protect Thermostat	X	X	X	X	X
10	135-319	Wire Shield	X	X	X	X	X
11	8611-006	Ground Terminal	X	X	X	X	X
12	3000-1231	Compressor Power Plug	X	X	X	X	X
13	3000-1223	Compressor Solenoid Plug	X	X	X	X	X
14	5650-044	Solenoid Valve Plug	X	X	X	X	X
15	8401-002	Contactors 3 Pole 25 Amp	X	X	X	X	X
16	8201-126	3-PH Line Monitor	X	X	X	X	X
17	8407-048	Transformer 75VA with Circuit Breaker	X	X	X	X	X
18	8201-128	Fan Logic Control	X	X	X	X	X
19	8614-052	3.15 Amp Fuse	X	X	X	X	X
20	8201-113	Dehum Logic Board	X	X	X	X	X
21	8201-088	Compressor Control Module	X	X	X	X	X
23	8408-043	Fan Control Thermistor	X	X	X	X	X
24	S910-1816	Fan Control Resistor (Optional)	X	X	X	X	X
25	116-332	Contactors Isolation Plate	X	X	X	X	X
26	5451-025	Rubber Grommet	X	X	X	X	X
27	5451-026	Nylon Flanged Bushing	X	X	X	X	X
28	910-1914	Overflow Switch Assembly	X	X	X	X	X

CONTROL PANEL COMPONENTS – 460V 3 PHASE

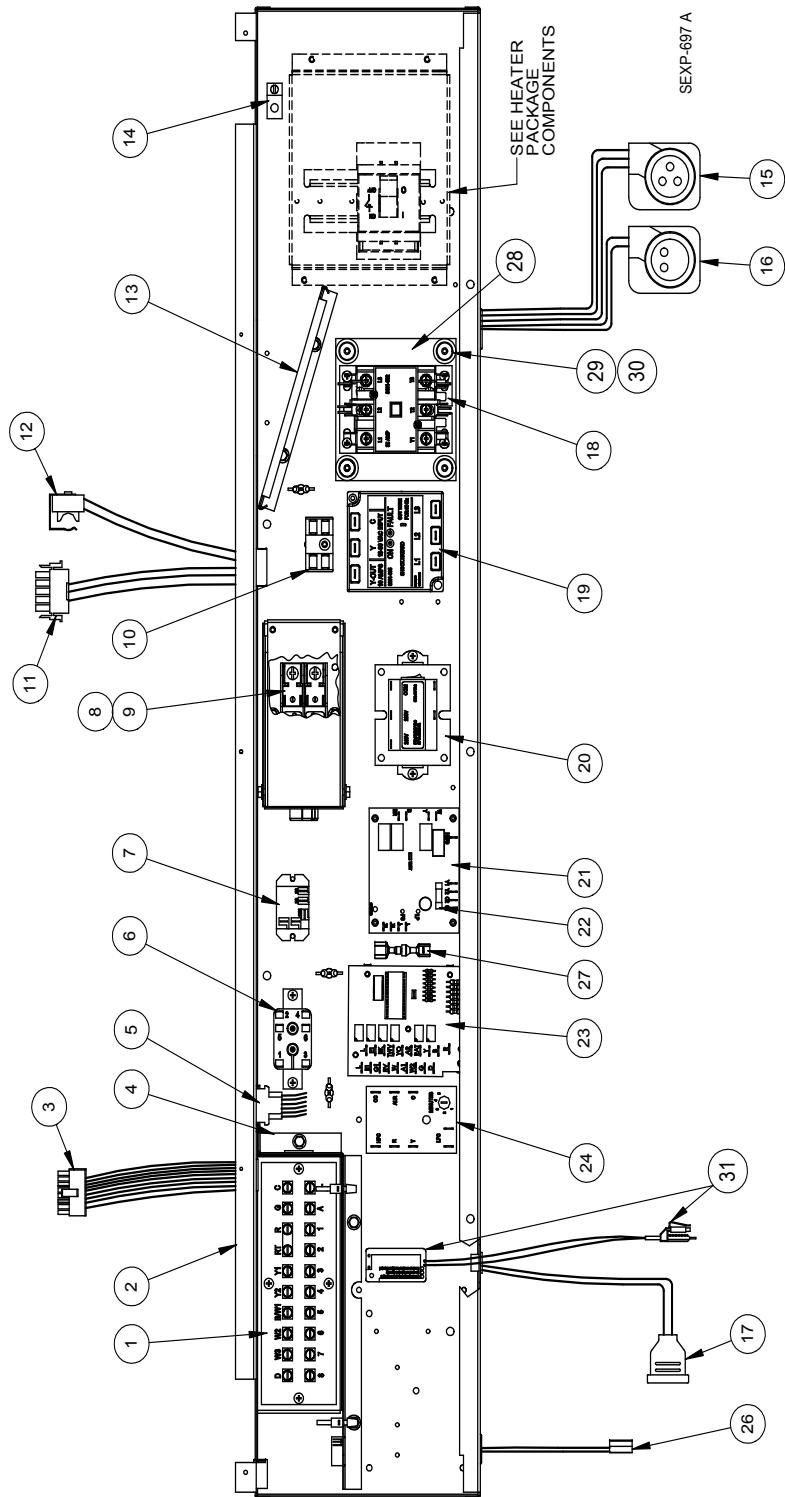

CONTROL PANEL COMPONENTS – 460V 3 PHASE

Drawing No.	Part Number	Description	I30A1DC	I36A1DC	I42A1DC	I48A1DC	I60A1DC
1	8607-032	Low Voltage Terminal Strip	X	X	X	X	X
2	517-391	Control Panel	X	X	X	X	X
3	3000-1396	16 pin 24V Indoor Blower Motor Control	X	X	X	X	X
4	117-319	Low Voltage Terminal Box	X	X	X	X	X
5	3000-1397	6 Pin Elect. Heat	X	X	X	X	X
6	8201-062	Relay	X	X	X	X	X
7	8201-130	Relay	X	X	X	X	X
8	8614-041	Fuse Block	X	X	X	X	X
9	<i>See separate chart below for Item #9</i>						
10	8607-017	Terminal Block	X	X	X	X	X
11	3000-1398	5 Pin Indoor Blower Motor Power	X	X	X	X	X
12	8408-048	Freeze Protect Thermostat	X	X	X	X	X
13	135-319	Wire Shield	X	X	X	X	X
14	8611-006	Ground Terminal	X	X	X	X	X
15	3000-1231	Compressor Power Plug	X	X	X	X	X
16	3000-1223	Compressor Solenoid Plug	X	X	X	X	X
17	5650-044	Solenoid Valve Plug	X	X	X	X	X
18	8401-002	Contactors 3 Pole 25 Amp	X	X	X	X	X
19	8201-126	3-PH Line Monitor	X	X	X	X	X
20	8407-048	Transformer 75VA with Circuit Breaker	X	X	X	X	X
21	8201-128	Fan Logic Control	X	X	X	X	X
22	8614-052	3.15 Amp Fuse	X	X	X	X	X
23	8201-113	Dehum Logic Board	X	X	X	X	X
24	8201-088	Compressor Control Module	X	X	X	X	X
26	8408-043	Fan Control Thermistor	X	X	X	X	X
27	S910-1816	Fan Control Resistor (Optional)	X	X	X	X	X
28	116-332	Contactors Isolation Plate	X	X	X	X	X
29	5451-025	Rubber Grommet	X	X	X	X	X
30	5451-026	Nylon Flanged Bushing	X	X	X	X	X
31	910-1914	Overflow Switch Assembly	X	X	X	X	X

		With Vent	No Vent
9	I30H1DC	(2) Part #8614-046 5A Class CC Fuse	(2) Part #8614-047 3.2A Class CC Fuse
	I36H1DC	(2) Part #8614-042 7A Class CC Fuse	(2) Part #8614-046 5A Class CC Fuse
	I42H1DC	(2) Part #8614-042 7A Class CC Fuse	(2) Part #8614-046 5A Class CC Fuse
	I48H1DC	(2) Part #8614-042 7A Class CC Fuse	(2) Part #8614-046 5A Class CC Fuse
	I60H1DC	(2) Part #8614-043 10A Class CC Fuse	(2) Part #8614-042 7A Class CC Fuse

ELECTRIC HEATER COMPONENTS

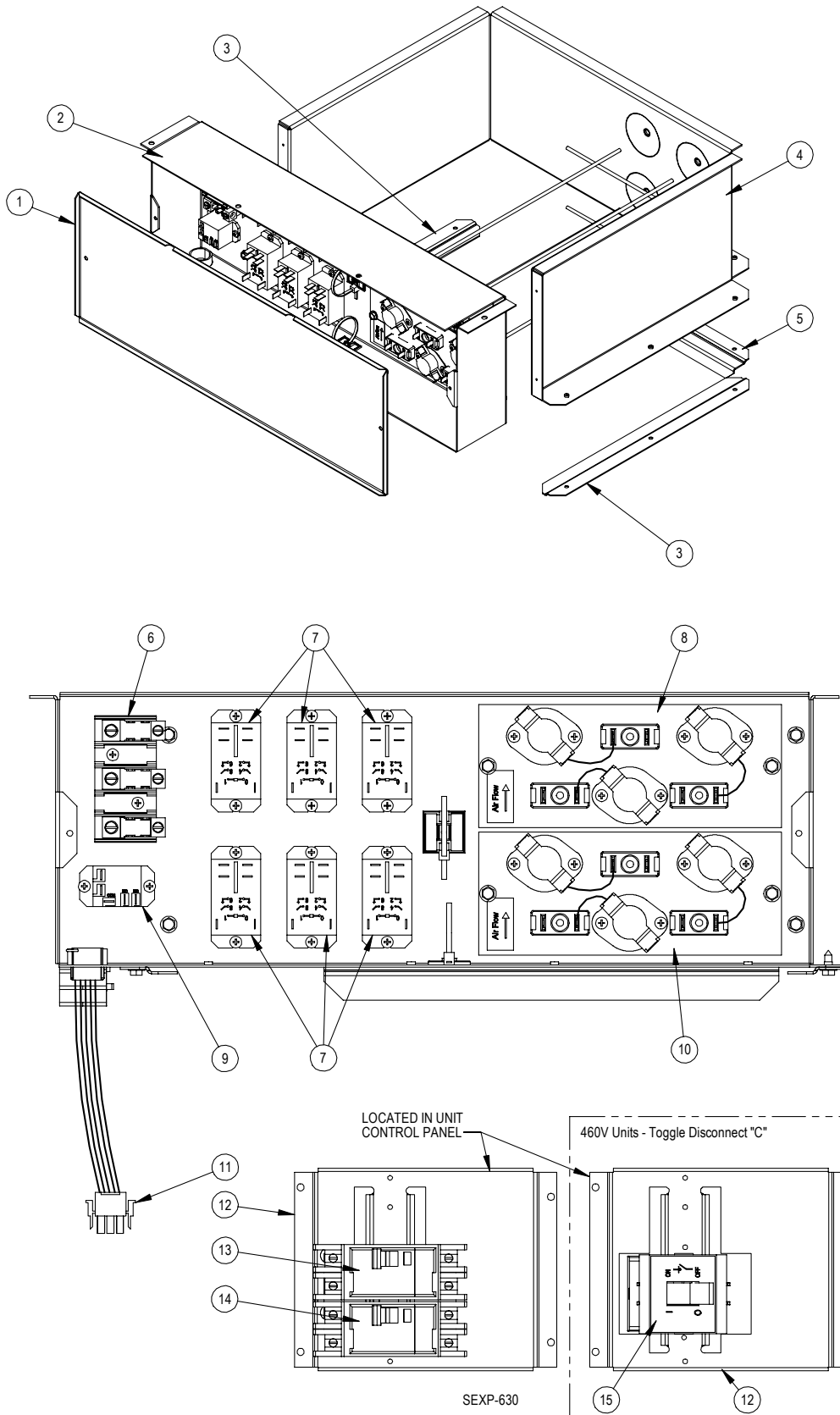

ELECTRIC HEATER COMPONENTS

Drawing			I30A1DA0Z	I30A1DA05	I30A1DA10	I36A1DA0Z	I36A1DA05	I36A1DA10	I36A1DA15	I42A1DA0Z	I42A1DA05	I42A1DA10	I42A1DA15	I48A1DA0Z	I48A1DA05	I48A1DA10	I48A1DA15	I48A1DA20	I60A1DA0Z	I60A1DA05	I60A1DA10	I60A1DA15	I60A1DA20	
Drawing No.	Part No.	Description																						
1	143-148	Heater Box Cover	X	X	X	X	X	X	X	X	X	X	X	X	X	X	X	X	X	X	X	X	X	X
2	117-313	Heater Front Plate	X	X	X	X	X	X	X	X	X	X	X	X	X	X	X	X	X	X	X	X	X	X
3	103-486	Side Blower Offset	2	2	2	2	2	2	2	2	2	2	2	2	2	2	2	2	2	2	2	2	2	2
4	117-307	Heater Wrapper	X	X	X	X	X	X	X	X	X	X	X	X	X	X	X	X	X	X	X	X	X	X
5	103-487	Rear Blower Angle	X	X	X	X	X	X	X	X	X	X	X	X	X	X	X	X	X	X	X	X	X	X
7	8401-036	Contactora 2-Pole 30A		X	2		X	2	3		X	2	2		X	2	3	4		X	2	3	4	
8	142-159	Heater Blank Off Plate	X	X	X	X	X	X		X	X	X		X	X	X			X	X	X			
	8604-135	Heat Strip 5KW							X				X				X						X	
	8604-136	Heat Strip 10KW																X						X
9	8201-130	Relay		X	X		X	X	X		X	X	X		X	X	X	X		X	X	X	X	X
10	142-159	Heater Blank Off Plate	X			X				X				X					X					
	8604-135	Heat Strip 5KW		X			X				X				X					X				
	8604-136	Heat Strip 10KW			X			X	X			X	X			X	X	X				X	X	X
	8604-134	Heat Strip 4KW													X									
11	3000-1402	6-Pin Electric Heater Wire Harness		X	X		X	X	X		X	X	X		X	X	X	X		X	X	X	X	X
12	127-418	Circuit Breaker Base	X	X	X	X	X	X	X	X	X	X	X	X	X	X	X	X	X	X	X	X	X	X
13	8615-037	Circuit Breaker 30A 2-Pole			X																			
	8615-041	Circuit Breaker 60A 2-Pole			X			X	X			X	X				X	X					X	X
14	8615-038	Circuit Breaker 35A 2-Pole	X	X																				
	8615-040	Circuit Breaker 50A 2-Pole												X	X									
	8615-055	Circuit Breaker 40A 2-Pole				X	X		X				X											
	8615-041	Circuit Breaker 60A 2-Pole														X		X	X	X	X	X	X	X
	8615-039	Circuit Breaker 45A 2-Pole								X	X					X	X							

ELECTRIC HEATER COMPONENTS

Drawing No.	Part No.	Description	I30A1DB0Z	I30A1DB06	I30A1DB09	I36A1DB0Z	I36A1DB06	I36A1DB09	I36A1DB15	I42A1DB0Z	I42A1DB06	I42A1DB09	I42A1DB15	I48A1DB0Z	I48A1DB06	I48A1DB09	I48A1DB15	I48A1DB18	I60A1DB0Z	I60A1DB06	I60A1DB09	I60A1DB15	I60A1DB18	
1	143-148	Heater Box Cover	X	X	X	X	X	X	X	X	X	X	X	X	X	X	X	X	X	X	X	X	X	X
2	117-313	Heater Front Plate	X	X	X	X	X	X	X	X	X	X	X	X	X	X	X	X	X	X	X	X	X	X
3	103-486	Side Blower Offset	2	2	2	2	2	2	2	2	2	2	2	2	2	2	2	2	2	2	2	2	2	2
4	117-307	Heater Wrapper	X	X	X	X	X	X	X	X	X	X	X	X	X	X	X	X	X	X	X	X	X	X
5	103-487	Rear Blower Angle	X	X	X	X	X	X	X	X	X	X	X	X	X	X	X	X	X	X	X	X	X	X
6	8607-014	Terminal Block																X						X
7	8401-036	Contacto 2-Pole 30A		3	3		3	3	6		3	3	6		3	3	6	6		3	3	6	6	
8	142-159	Heater Blank Off Plate	X	X	X	X	X	X		X	X	X		X	X	X			X	X	X			
	8604-137	Heat Strip 6KW							X				X				X						X	
	8604-138	Heat Strip 9KW																X						X
9	8201-130	Relay		X	X		X	X	X		X	X	X		X	X	X	X		X	X	X	X	X
10	142-159	Heater Blank Off Plate	X			X				X				X					X					
	8604-137	Heat Strip 6KW		X			X				X				X					X				
	8604-138	Heat Strip 9KW			X			X	X			X	X			X	X	X				X	X	X
11	3000-1402	6-Pin Electric Heater Wire Harness		X	X		X	X	X		X	X	X		X	X	X	X		X	X	X	X	X
12	127-418	Circuit Breaker Base	X	X	X		X	X	X	X	X	X	X	X	X	X	X	X	X	X	X	X	X	X
14	8615-051	Circuit Breaker 25A 3-Pole	X	X																				
	8615-042	Circuit Breaker 35A 3-Pole			X			X		X	X	X		X	X	X								
	8615-052	Circuit Breaker 30A 3-Pole				X	X																	
	8615-044	Circuit Breaker 45A 3-Pole																		X	X	X	X	X
	8615-045	Circuit Breaker 50A 3-Pole																						
	8615-046	Circuit Breaker 60A 3-Pole							X				X				X	X					X	X

ELECTRIC HEATER COMPONENTS

Drawing No.	Part No.	Description	I30A1DC0Z	I30A1DC06	I30A1DC09	I36A1DC0Z	I36A1DC06	I36A1DC09	I36A1DC15	I42A1DC0Z	I42A1DC06	I42A1DC09	I42A1DC15	I48A1DC0Z	I48A1DC06	I48A1DC09	I48A1DC15	I48A1DC18	I60A1DC0Z	I60A1DC06	I60A1DC09	I60A1DC15	I60A1DC18	
1	143-148	Heater Box Cover	X	X	X	X	X	X	X	X	X	X	X	X	X	X	X	X	X	X	X	X	X	X
2	117-313	Heater Front Plate	X	X	X	X	X	X	X	X	X	X	X	X	X	X	X	X	X	X	X	X	X	X
3	103-486	Side Blower Offset	2	2	2	2	2	2	2	2	2	2	2	2	2	2	2	2	2	2	2	2	2	2
4	117-307	Heater Wrapper	X	X	X	X	X	X	X	X	X	X	X	X	X	X	X	X	X	X	X	X	X	X
5	103-487	Rear Blower Angle	X	X	X	X	X	X	X	X	X	X	X	X	X	X	X	X	X	X	X	X	X	X
6	8607-014	Terminal Block							X				X				X						X	
7	8401-036	Contactora 2-Pole 30A		2	2		2	2	6		2	2	6		2	2	6	4		2	2	6	4	
8	142-159	Heater Blank Off Plate	X	X	X	X	X	X		X	X	X		X	X	X			X	X	X			
	8604-139	Heat Strip 6KW							X				X				X						X	
	8604-140	Heat Strip 9KW																X						X
9	8201-130	Relay		X	X		X	X	X		X	X	X		X	X	X	X		X	X	X	X	X
10	142-159	Heater Blank Off Plate	X			X				X				X					X					
	8604-139	Heat Strip 6KW		X			X				X				X					X				
	8604-140	Heat Strip 9KW			X			X	X			X	X			X	X	X				X	X	X
11	3000-1402	6-Pin Electric Heater Wire Harness		X	X		X	X	X		X	X	X		X	X	X	X		X	X	X	X	X
12	127-418	Circuit Breaker Base	X	X	X	X	X	X	X	X	X	X	X	X	X	X	X	X	X	X	X	X	X	X
15	8615-067	Toggle Disconnect 40A 460V	X	X	X	X	X	X	X	X	X	X	X	X	X	X	X	X	X	X	X	X	X	X

VENT BOX (ONLY) COMPONENTS

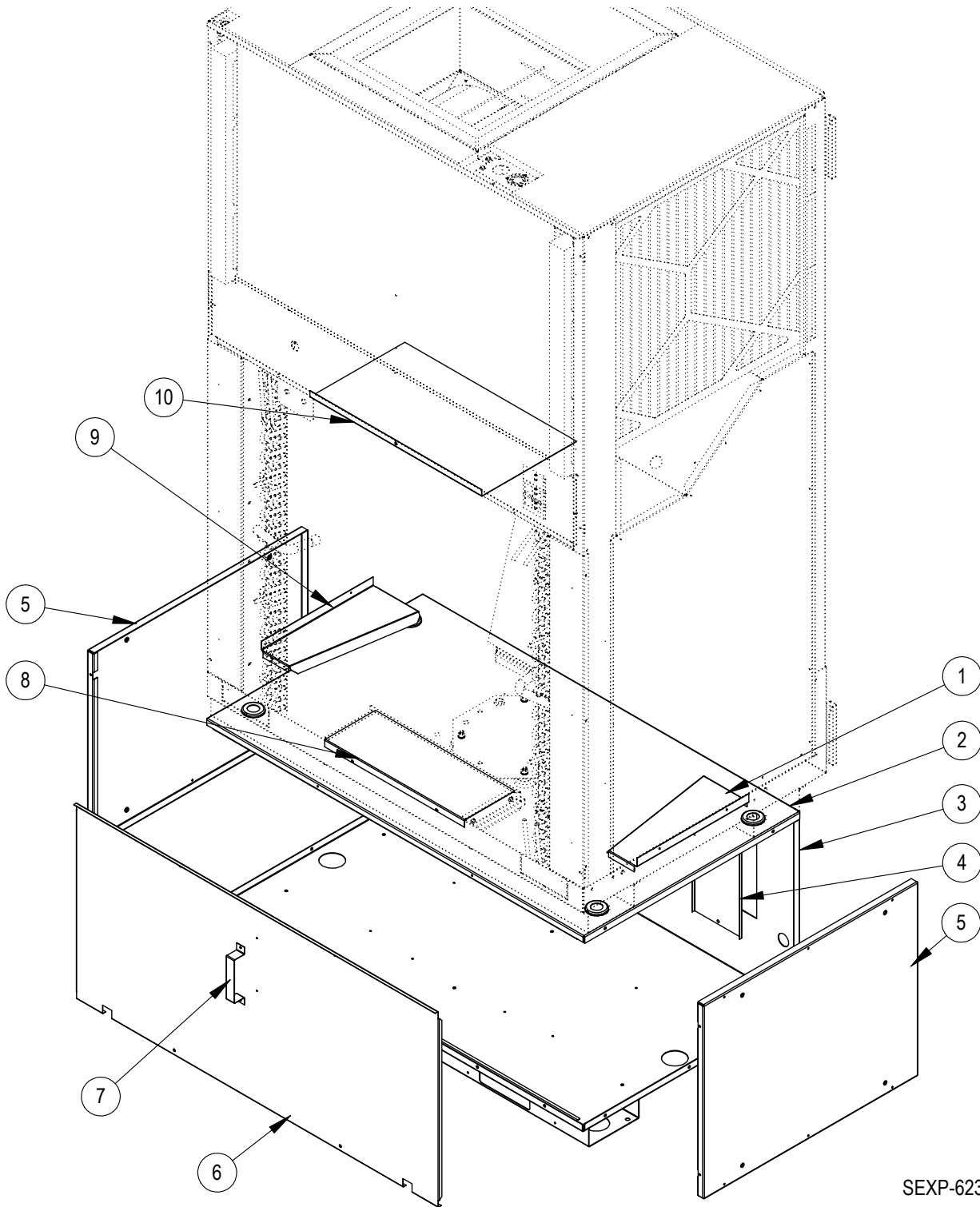

SEXP-623

VENT BOX (ONLY) COMPONENTS

Drawing No.	Part Number	Description	Vent Box Only
1	S143X164	Right Side Intake Fill	X
2	507-298	Vent Box Top	X
3	S527-419	Vent Box Base	X
4	543-158	Drain Access Plate	2
5	S501-639	Vent Box Side	2
6	553-508	Vent Box Door	X
7	113-441	Door Latch Bracket	X
8	S143-160	Lower Intake Fill	X
9	S143Y164	Left Side Intake Fill	X
10	S143-161	Upper Intake Fill	X

CRV COMPONENTS

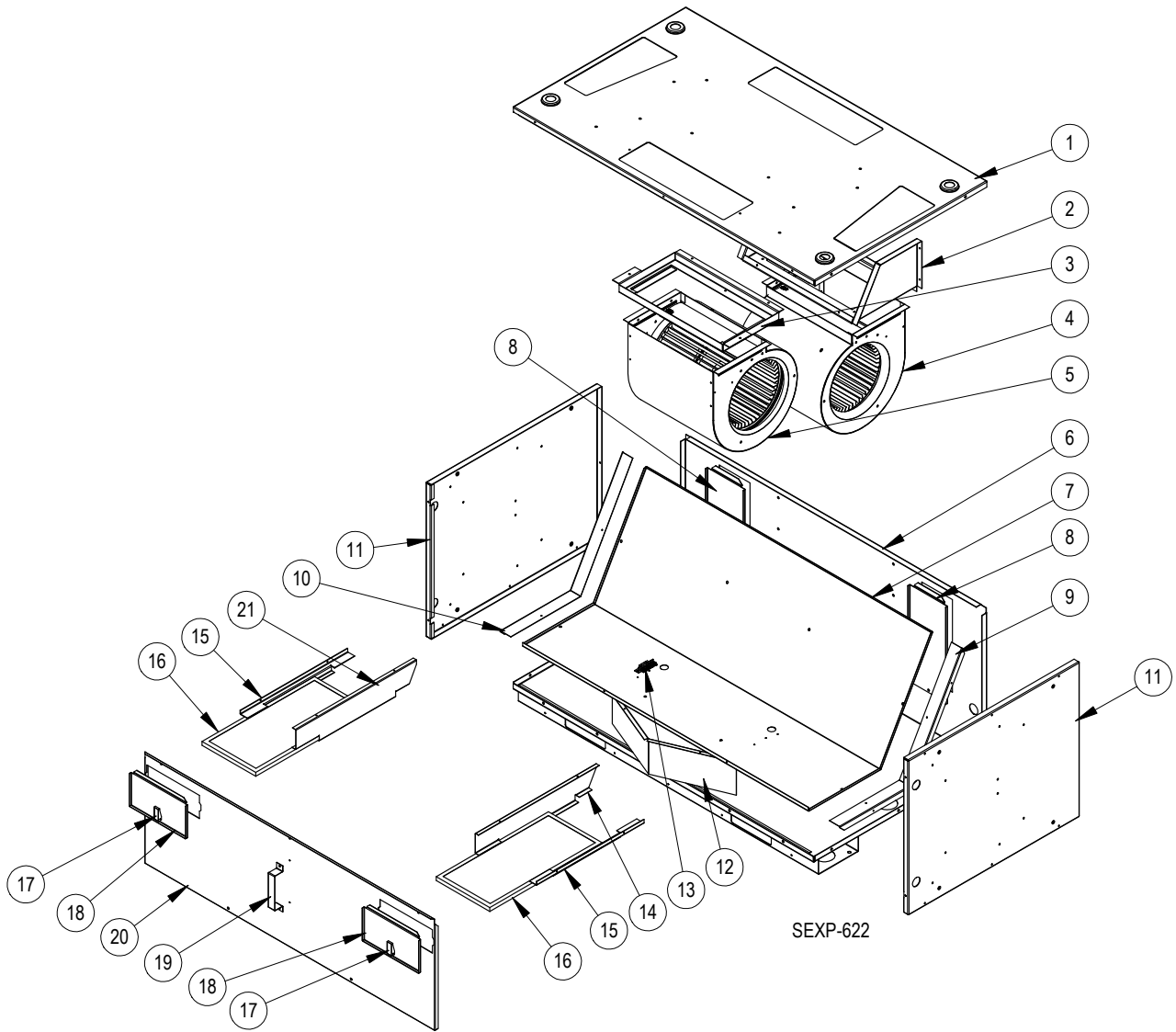

CRV COMPONENTS

Drawing No.	Part Number	Description	CRV
1	S507-297	Vent Box Top	X
2	103-489	Rear Blower Offset	X
3	103-488	Front Blower Offset	X
4	900-318-001	Exhaust Blower Assembly	X
5	900-318-002	Intake Blower Assembly	X
6	S527-419	Vent Box Base	X
7	521-459	Partition	X
8	543-158	Drain Access Plate	2
9	505X1260	Right Partition Angle	X
10	505Y1260	Left Partition Angle	X
11	S501-638	Vent Box Side	2
12	569-179	Baffle	X
13	S910-1809	Terminal Block Assembly	X
14	141X382	Right Lower Filter Bracket	X
15	141-381	Filter Angle	2
16	7003-064	Vent Intake Filter	2
17	1171-053	Swell Latch	2
18	S153-506	Filter Door	2
19	113-441	Door Latch Bracket	X
20	S553-507	Blower Door	X
21	141Y382	Left Lower Filter Bracket	X
NS	3000-1403	Intake/Exhaust Power Plug	2
NS	3000-1404	Intake/Exhaust Speed Plug	2
NS	3000-1406	Vent Section Plug	X
NS	3000-1411	Unit Control Panel Plug	X
NS	8201-062	Relay (in unit Control Panel)	X

NS = Not Shown

MODULATING CRV COMPONENTS

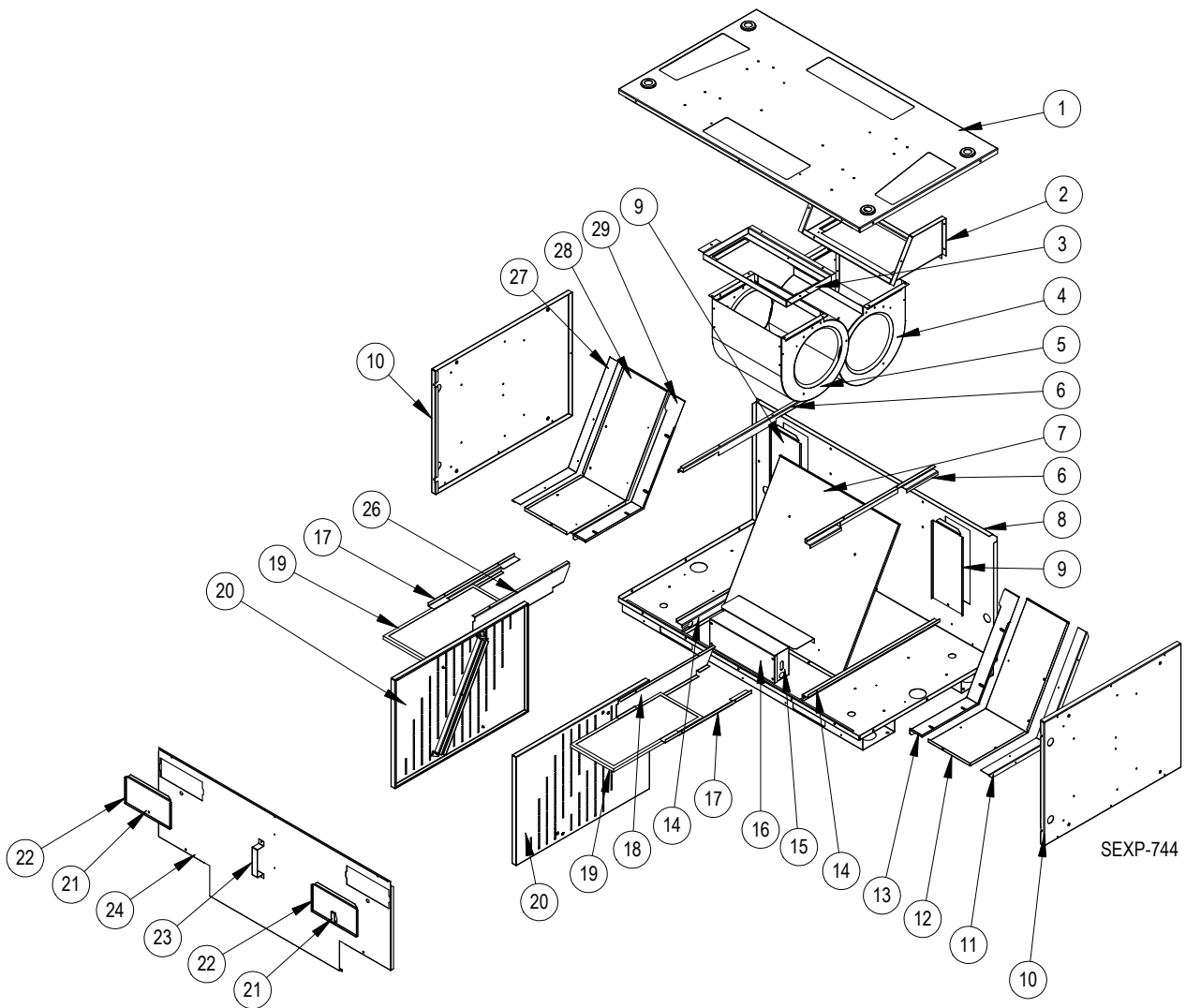

MODULATING CRV COMPONENTS

Drawing No.	Part Number	Description	Modulating CRV
1	S507-297	Vent Box Top	X
2	103-489	Rear Blower Offset	X
3	103-488	Front Blower Offset	X
4	900-319-003	Exhaust Blower Assembly	X
5	900-319-004	Intake Blower Assembly	X
6	141-379	Cassette Upper Rail	2
7	521-457	Partition	X
8	S527-419	Vent Box Base	X
9	543-158	Drain Access Plate	2
10	S501-638	Vent Box Side	2
11	505X1260	Right Partition Angle	X
12	521-464	Right Side Partition	X
13	S105X1258	Right Cassette Seal Angle	X
14	141-380	Cassette Lower Rail	2
15	Control Panel	See Control Panel section	x
16	153-511	Control Panel Cover	X
17	141-381	Filter Angle	2
18	141X382	Right Lower Filter Bracket	X
19	7003-064	Vent Intake Filter	2
20	139-322	Restrictor Plate	2
21	1171-053	Swell Latch	2
22	S153-506	Filter Door	2
23	113-441	Door Latch Bracket	X
24	S553-505	Cassette Door	X
26	141Y382	Left Lower Filter Bracket	X
27	105Y1260	Left Partition Angle	X
28	521-465	Left Side Partition	X
29	S105Y1258	Left Cassette Seal Angle	X

MODULATING CRV CONTROL PANEL COMPONENTS

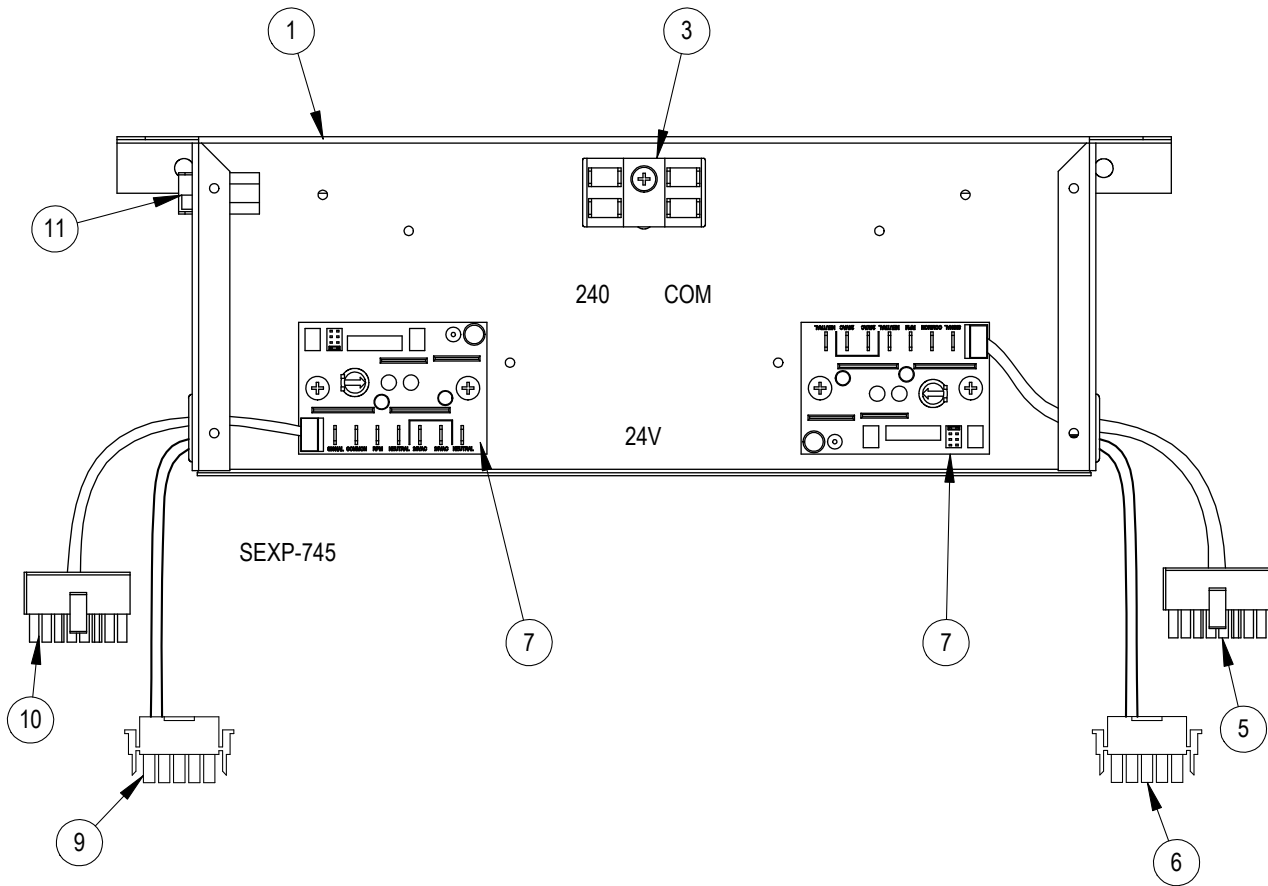

MODULATING CRV CONTROL PANEL COMPONENTS

Drawing No.	Part Number	Description	Modulating CRV Control Panel
1	117-323	Control Panel	X
3	8607-017	Terminal Block	X
5	3000-1407	Exhaust Speed Plug	X
6	3000-1331	Intake Plower Plug	X
7	8201-124	Blower Control Board	2
9	3000-1356	Intake Speed Plug	X
10	3000-1358	Exhaust Power Plug	X
11	3000-1409	Vent Section Plug	X
NS	3000-1408	Extension Plug	X
NS	3000-1405	Unit Control Panel Plug	X
NS	8201-013	Relay (in unit Control Panel)	X

NS = Not Shown

ERV COMPONENTS

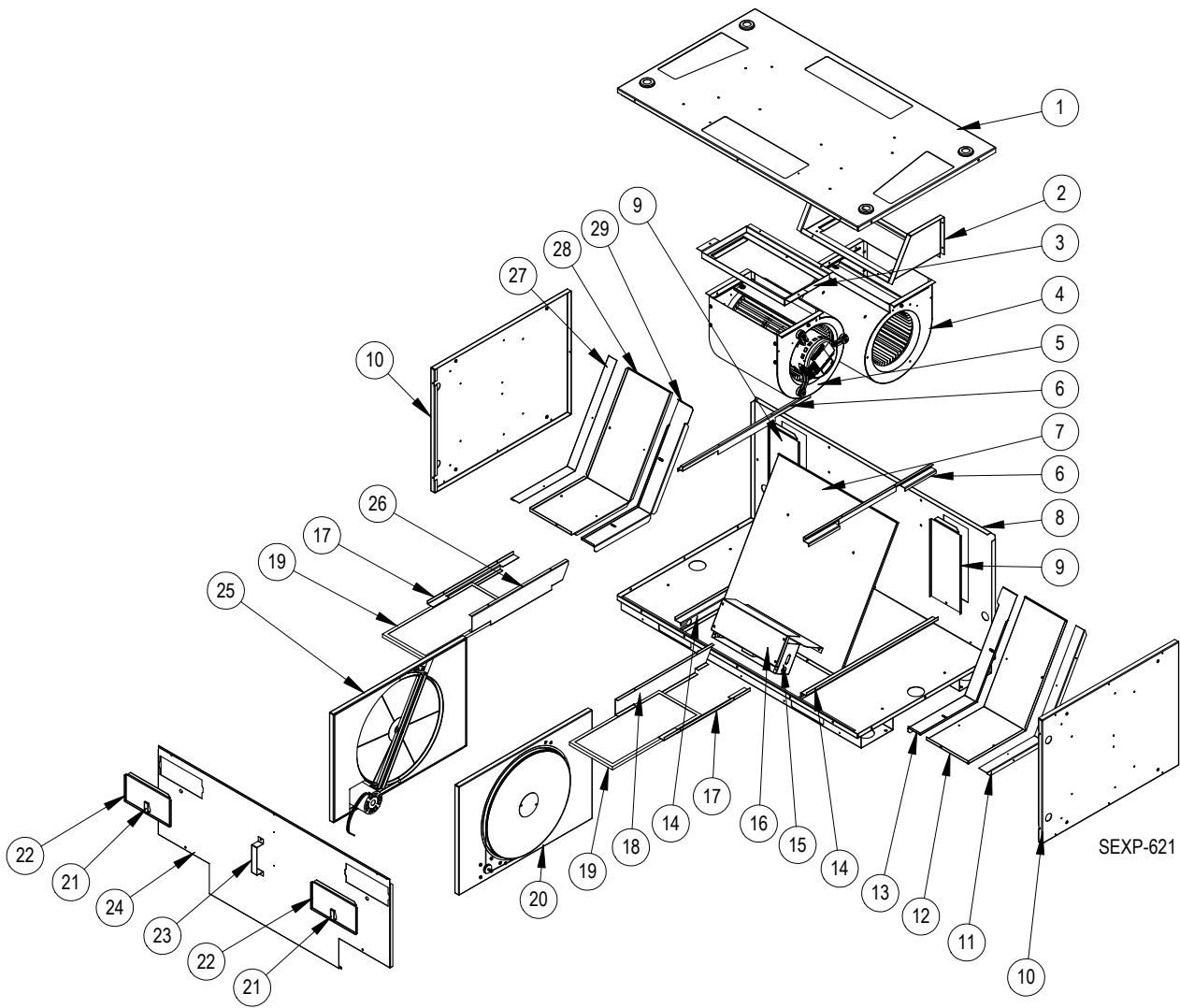

ERV COMPONENTS

Drawing No.	Part Number	Description	ERV
1	S507-297	Vent Box Top	X
2	103-489	Rear Blower Offset	X
3	103-488	Front Blower Offset	X
4	900-319-001	Exhaust Blower Assembly	X
5	900-319-002	Intake Blower Assembly	X
6	141-379	Cassette Upper Rail	2
7	521-457	Partition	X
8	S527-419	Vent Box Base	X
9	543-158	Drain Access Plate	2
10	S501-638	Vent Box Side	2
11	505X1260	Right Partition Angle	X
12	521-464	Right Side Partition	X
13	S105X1258	Right Cassette Seal Angle	X
14	141-380	Cassette Lower Rail	2
15	Control Panel	See Control Panel section	x
16	153-511	Control Panel Cover	X
17	141-381	Filter Angle	2
18	141X382	Right Lower Filter Bracket	X
19	7003-064	Vent Intake Filter	2
20	5070-055	Right Cassette Assembly - Complete See cassette section for individual parts	X
21	1171-053	Swell Latch	2
22	S153-506	Filter Door	2
23	113-441	Door Latch Bracket	X
24	S553-505	Cassette Door	X
25	5070-056	Left Cassette Assembly - Complete See cassette section for individual parts	X
26	141Y382	Left Lower Filter Bracket	X
27	105Y1260	Left Partition Angle	X
28	521-465	Left Side Partition	X
29	S105Y1258	Left Cassette Seal Angle	X

ERV CONTROL PANEL COMPONENTS

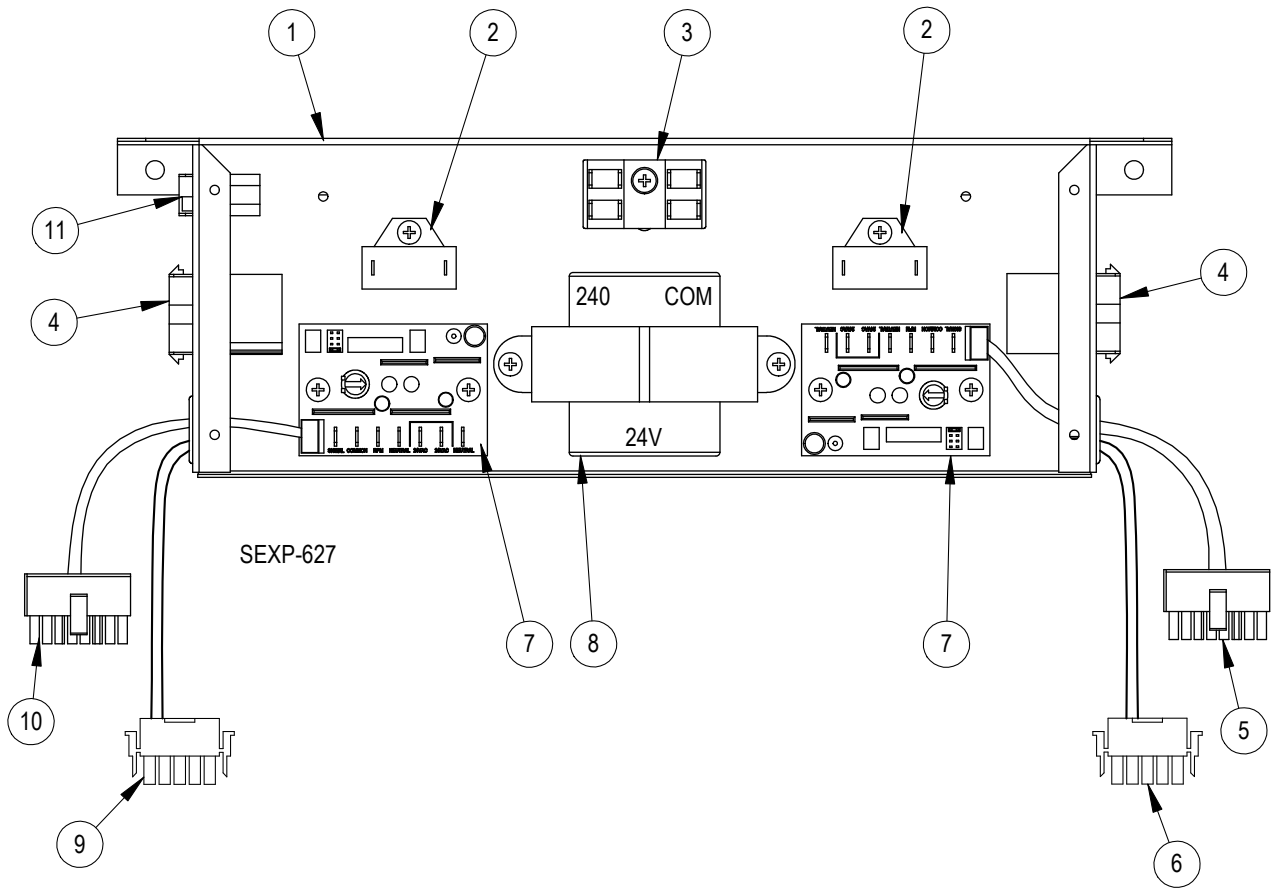

ERV CONTROL PANEL COMPONENTS

Drawing No.	Part Number	Description	ERV Control Panel
1	117-323	Control Panel	X
2	8552-070	3MFD 250V Capacitor	2
3	8607-017	Terminal Block	X
4	3000-1410	Cassette Motor Plug	2
5	3000-1407	Exhaust Speed Plug	X
6	3000-1331	Intake Plover Plug	X
7	8201-124	Blower Control Board	2
8	8407-043	60VA Transformer	X
9	3000-1356	Intake Speed Plug	X
10	3000-1358	Exhaust Power Plug	X
11	3000-1409	Vent Section Plug	X
NS	3000-1408	Extension Plug	X
NS	3000-1405	Unit Control Panel Plug	X
NS	8201-013	Relay (in unit Control Panel)	X

NS = Not Shown

ERV CASSETTE COMPONENTS

Drawing No.	Part Number	Description	5070-055 Right Cassette	5070-056 Left Cassette
1	5501-018	Pulley	X	X
2	5070-030 	Drive Belt	X	X
3	5070-043	Cassette Wheel	X	X
4	8101-016	Motor	X	X
5	1012-164	Machine Screw	2	2
6	8611-111	Nylon Spacer	2	2
7	142-104	Hub Cover	X	X
8	1912-012	Wheel Shaft	X	X
9	105-1259	Cassette Wheel Angle	X	X
10	539X275	Right Hand Cassette Plate	X	
10	539Y275	Left Hand Cassette Plate		X
NS	8620-204	ERV Bearing, Shaft & Hardware Kit	X	X
NS	8620-205	ERV Shaft & Hardware Kit	X	X

NS = Not Shown

CRV/ERV BLOWER COMPONENTS

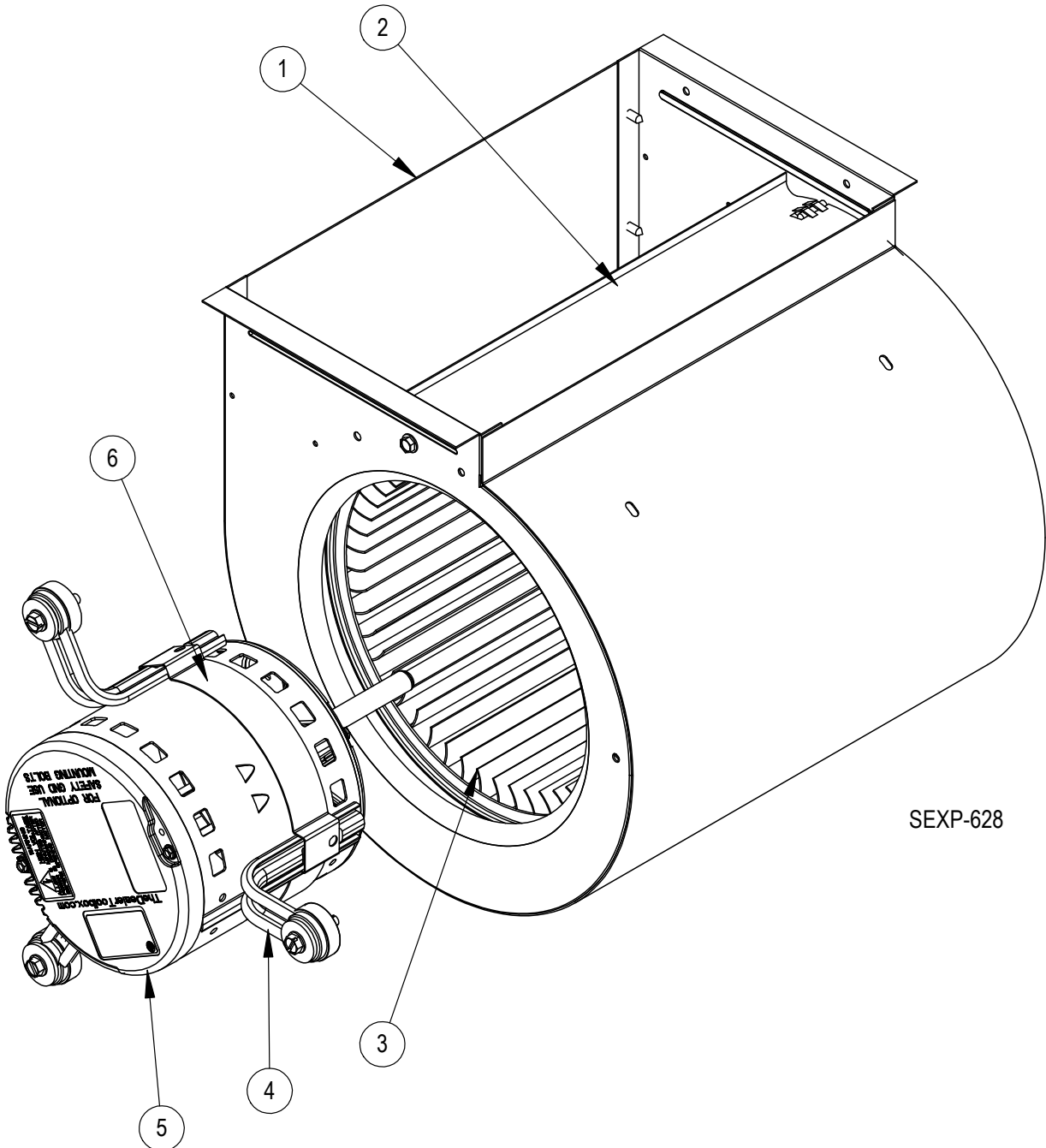

CRV/ERV BLOWER COMPONENTS

Drawing No.	Part Number	Description	900-318-001	900-318-002	900-319-001	900-319-002	900-319-003	900-319-004
1	151-124	Blower Housing	X	X	X	X	X	X
2	144-129	Diffuser	X	X	X	X	X	X
3	5152-067	Blower Wheel	X	X	X	X	X	X
4	8200-046	Motor Mount Arm	3	3	3	3	3	3
5	S8105-056-0104	1/3 HP Programmed Motor – CRV Exhaust	X					
5	S8105-056-0105	1/3 HP Programmed Motor – CRV Intake		X				
5	S8105-059-0106	1/3 HP Programmed Motor – ERV Exhaust			X			
5	S8105-059-0107	1/3 HP Programmed Motor – ERV Intake				X		
5	S8105-059-0140	1/3 HP Programmed Motor – Mod. CRV Exhaust					X	
5	S8105-059-0141	1/3 HP Programmed Motor – Mod. CRV Intake						X
6	8620-034	Motor Mount Band	X	X	X	X	X	X

SLEEVE COMPONENTS

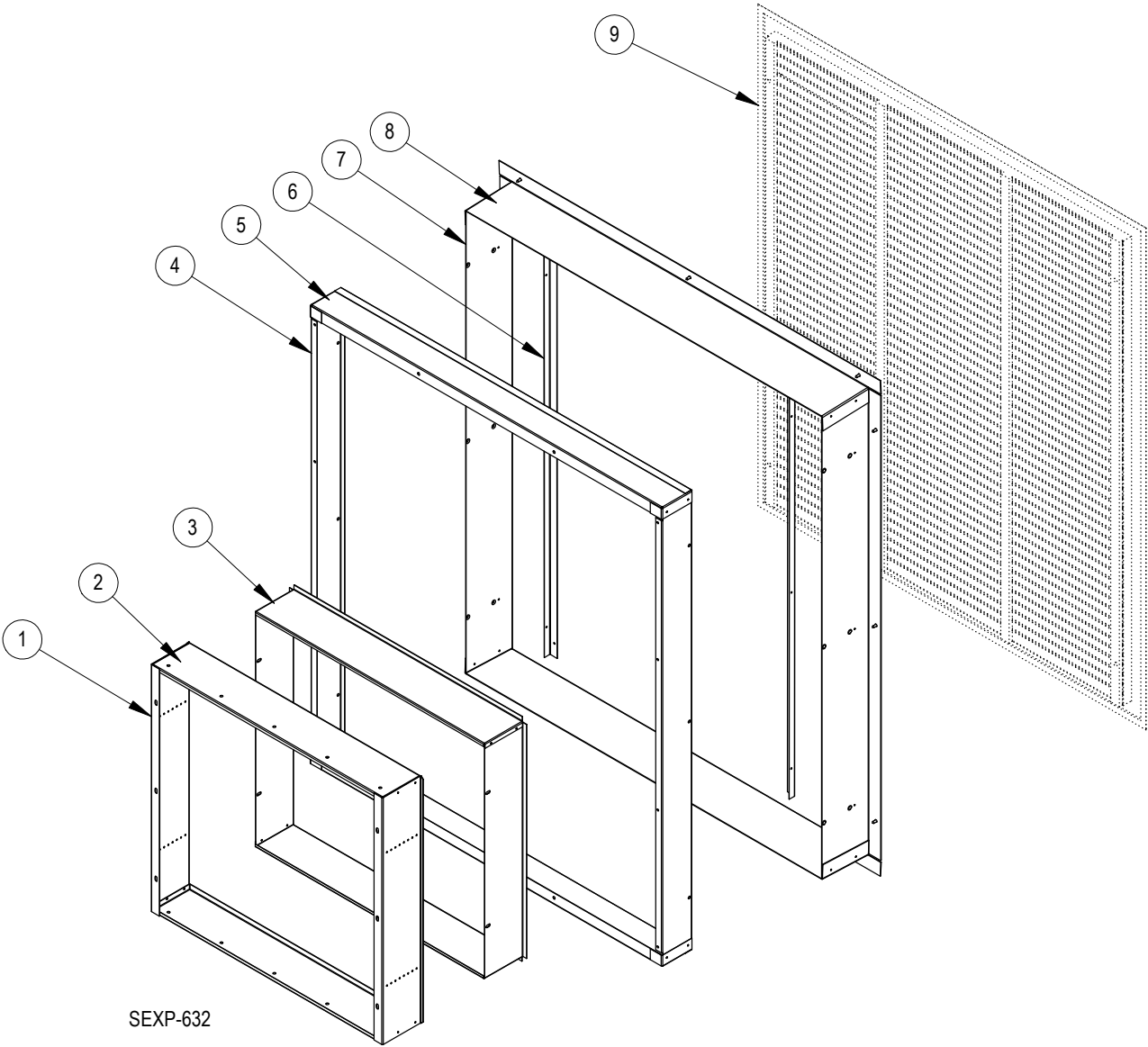

SEXP-632

SLEEVE COMPONENTS

Drawing No.	Part Number	Description	IWS-A	IWS-B	IWS-C
1	S111-188-8 4½" Deep	Outer Sleeve Side	X		
	S111-195-8 7" Deep			X	
	S111-202-8 12" Deep				X
2	S111-187-8 4½" Deep	Outer Sleeve End	X		
	S111-194-8 7" Deep			X	
	S111-201-8 12" Deep				X
3	111-189-8 4½" Deep	Inner Fan Sleeve Side	2		
	111-196-8 7" Deep			2	
	111-203-8 12" Deep				2
4	111-186-8 3½" Deep	Inner Sleeve Side	X		
	111-193-8 6" Deep			X	
	111-200-8 11" Deep				X
5	111-185-8 3½" Deep	Inner Sleeve End	X		
	111-192-8 6" Deep			X	
	111-199-8 11" Deep				X
6	105-1257-8	Grille Support Angle	2	2	2
7	111-184-8 5½" Deep	Outer Sleeve Side	X		
	111-191-8 8" Deep			X	
	111-198-8 13" Deep				X
8	111-183-8 5½" Deep	Outer Sleeve End	X		
	111-190-8 8" Deep			X	
	111-197-8 13" Deep				X
9	ILG-10	Outdoor Louver Grille - Clear anodized	X	X	X
	ILG-20	Outdoor Louver Grille - Medium Bronze	X	X	X
	ILG-30	Outdoor Louver Grille - Dark Bronze	X	X	X

RISER PLATFORM COMPONENTS

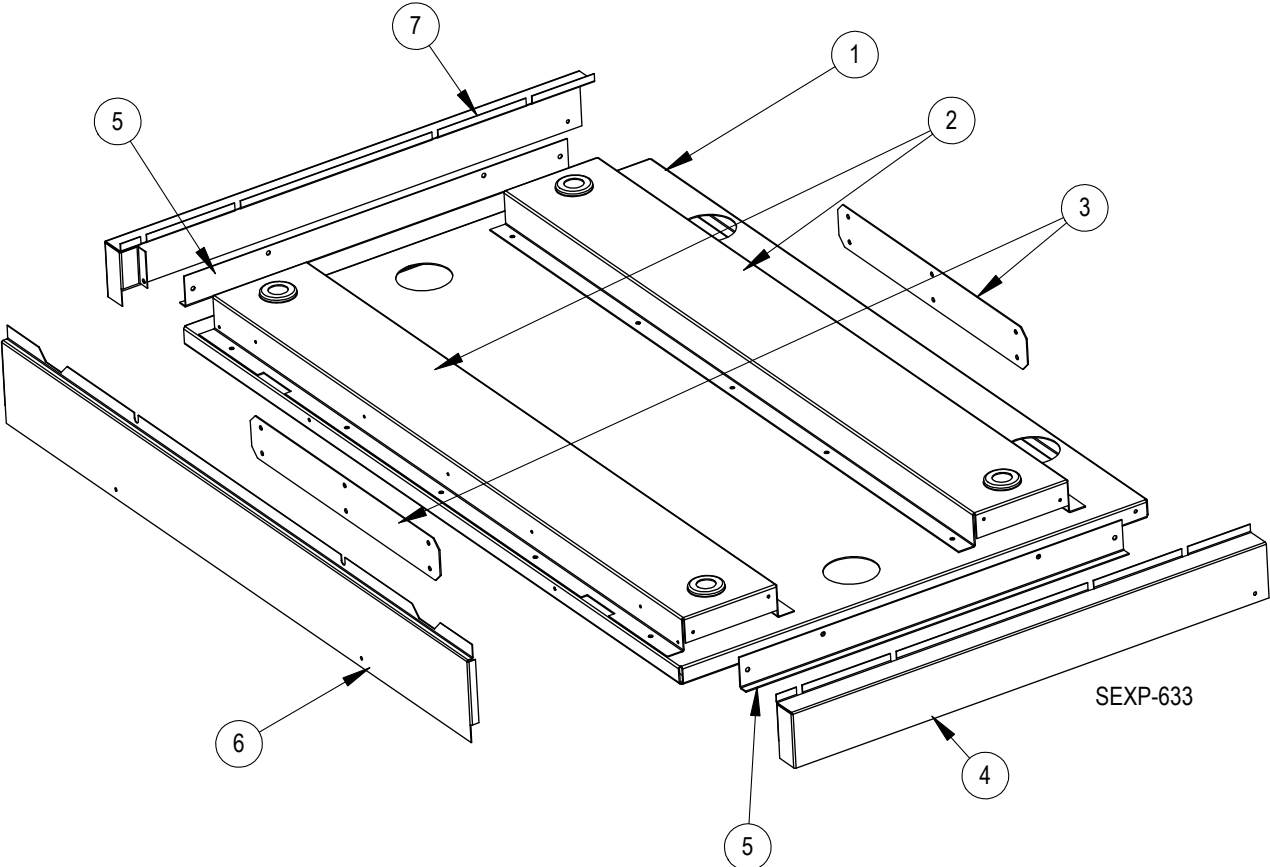

RISER PLATFORM COMPONENTS

Drawing No.	Part Number	Description	IRP-3-*	IRP-6-*
1	127-420-X	Base Plate	X	X
2	141-384 3"	Base Rail	2	
	141-385 6"			2
3	112-447	Base Connection Plate	2	2
4	135-311-* 3"	Right Side Trim	X	
	135-314-* 6"			X
5	105-1263 3"	Side Support Angle	2	
	105-1264 6"			2
6	135-309-* 3"	Front Trim	X	
	135-312-* 6"			X
7	135-310-* 3"	Left Side Trim	X	
	135-313-* 6"			X

* Exterior cabinet parts are manufactured with various paint color options. To ensure the proper paint color is received, reference the following codes:

Beige	-X
White	-1
Buckeye Gray	-4