REPLACEMENT PARTS MANUAL

WALL MOUNTED PACKAGE HEAT PUMPS

Models: W30H2 W30H2D
 W36H2 W36H2D

General Notes

- Revised and/or additional pages may be issued from time to time.
- A complete and current manual consists of pages shown in the following contents section.

Important

- Contact the installing and/or local Bard distributor for all parts requirements. Make sure you have the complete model and serial number available from the unit rating plates.

Contents

Description	Page
Cabinet Components	
♦ Exploded View	2
♦ Usage List	3
Functional Components	
♦ Exploded View	4
♦ Usage List	5
Functional Components - Dehum. Models	
♦ Usage List	6
Control Panel	
♦ Layout View	7
♦ Usage List	8
Control Panel	
♦ Layout View	9
♦ Usage List - Dehum.	10
Blower Housing	
♦ Exploded View	11
♦ Usage List	11



Bard Manufacturing Company, Inc.
Bryan, Ohio 43506
Since 1914...Moving ahead, just as planned.

Manual: 2110-596
Supersedes: **NEW**
File: Tab 17
Date: 10-01-13

CABINET COMPONENTS

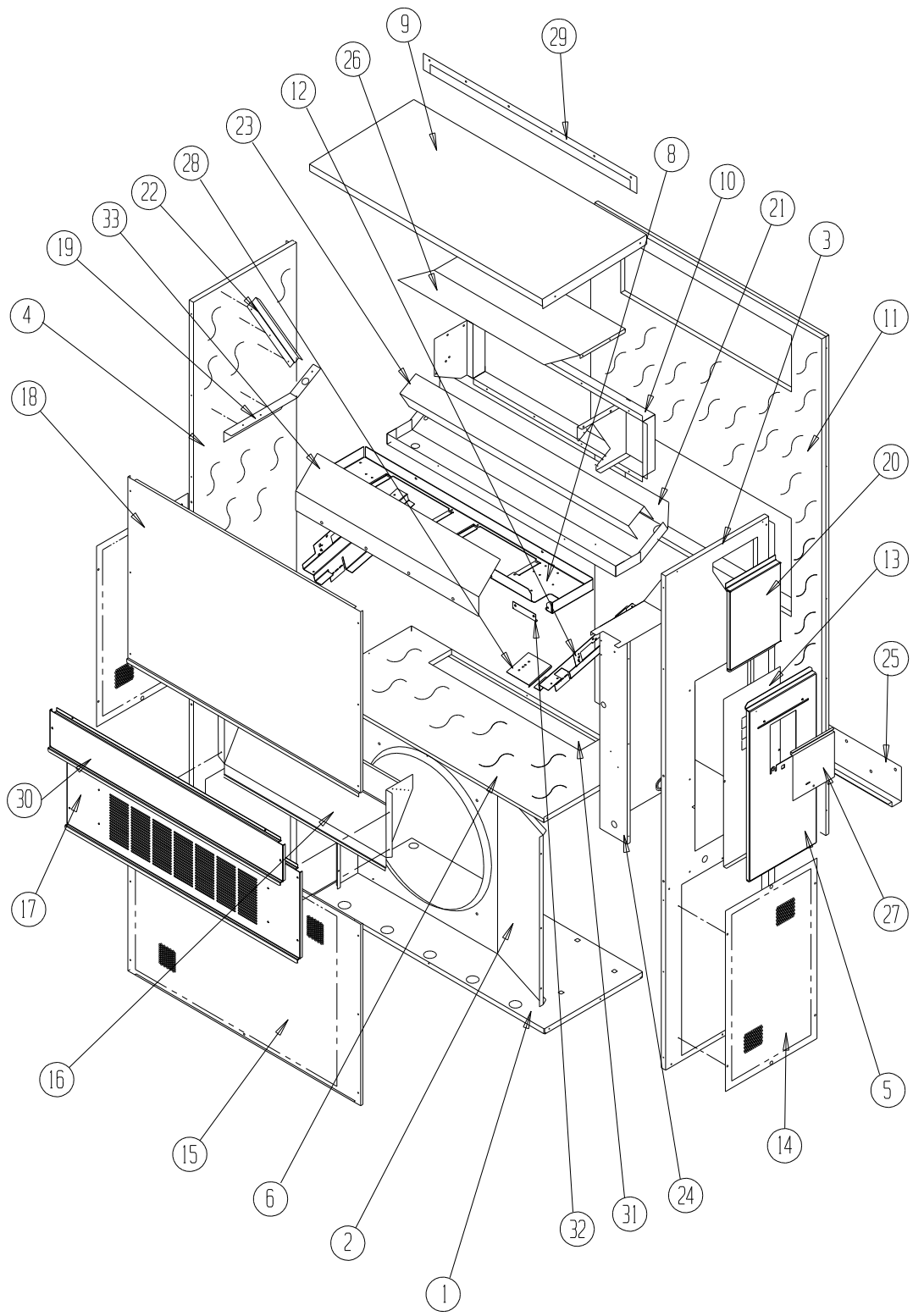

SEXP-688

CABINET COMPONENTS

Dwg No.	Part Number	Description	W30H2-A, B	W30H2-C	W30H2DA, B	W30H2DC	W36H2-A, B	W36H2-C	W36H2DA, B	W36H2DC
1	S127-471	Lower Base	X	X	X	X	X	X	X	X
1	S127-440 ③	Lower Base	X	X	X	X	X	X	X	X
2	125-022	Fan Shroud	X	X	X	X	X	X	X	X
2	125-057 ③	Fan Shroud	X	X	X	X	X	X	X	X
3	S501-684-* ①	Right Side	X	X	X	X	X	X	X	X
3	S501-722 ②	Right Side	X	X	X	X	X	X	X	X
3	S501-720 ③	Right Side	X	X	X	X	X	X	X	X
4	S501-711-* ①	Left Side	X	X	X	X	X	X	X	X
4	S501-723 ②	Left Side	X	X	X	X	X	X	X	X
4	S501-721 ③	Left Side	X	X	X	X	X	X	X	X
5	S533-228 ①	Control Panel Cover (Outer)	X	X	X	X	X	X	X	X
5	S533-236 ②	Control Panel Cover (Outer)	X	X	X	X	X	X	X	X
5	S533-235 ③	Control Panel Cover (Outer)	X	X	X	X	X	X	X	X
6	S521X466	Condenser Partition	X	X	X	X	X	X	X	X
8	121X467	Blower Partition	X	X	X	X	X	X	X	X
9	S507-308-* ①	Top	X	X	X	X	X	X	X	X
9	S507-320 ②	Top	X	X	X	X	X	X	X	X
9	S507-319 ③	Top	X	X	X	X	X	X	X	X
10	S111X030	Outlet Air Frame Assembly	X	X	X	X	X	X	X	X
11	S508-088	Back	X	X	X	X	X	X	X	X
11	S509-290 ②	Back	X	X	X	X	X	X	X	X
11	S508-222 ③	Back	X	X	X	X	X	X	X	X
12	113X480	Filter Bracket	2	2	2	2	2	2	2	2
13	S132-104	Control Panel Cover (Inner)	X		X		X		X	
13	S132-172	Control Panel Cover (Inner)		X		X		X		X
14	118-056-* ①	Side Grille	2	2	2	2	2	2	2	2
14	118-060 ②	Side Grille	2	2	2	2	2	2	2	2
14	118-067 ③	Side Grille	2	2	2	2	2	2	2	2
15	118-059-* ①	Condenser Grille	X	X	X	X	X	X	X	X
15	118-061 ②	Condenser Grille	X	X	X	X	X	X	X	X
15	118-066 ③	Condenser Grille	X	X	X	X	X	X	X	X
16	BFAD-3	Fresh Air Damper Assembly	X	X	X	X	X	X	X	X
17	S553-523-* ①	Vent Option Door	X	X	X	X	X	X	X	X
17	S553-540 ①	Vent Option Door with ERV	X	X	X	X	X	X	X	X
17	S553-550 ②	Vent Option Door	X	X	X	X	X	X	X	X
17	S553-549 ③	Vent Option Door	X	X	X	X	X	X	X	X
18	S514-241-* ①	Upper Front	X	X	X	X	X	X	X	X
18	S515-239 ②	Upper Front	X	X	X	X	X	X	X	X
18	S514-238 ③	Upper Front	X	X	X	X	X	X	X	X
19	105X850	Side Support	X	X	X	X	X	X	X	X
20	S543-175-* ①	Right Side Cover Plate (Outer)	X	X	X	X	X	X	X	X
20	S543-184 ②	Right Side Cover Plate (Outer)	X	X	X	X	X	X	X	X
20	S543-185 ③	Right Side Cover Plate (Outer)	X	X	X	X	X	X	X	X
21	S123-127	Drain Pan	X	X	X	X	X	X	X	X
21	S123-141 ③	Drain Pan	X	X	X	X	X	X	X	X
22	147-044	Evaporator Support	X	X	X	X	X	X	X	X
23	137-685	Bottom Evaporator Fill	X	X			X	X		
23	137-722	Bottom Evaporator Fill			X	X			X	X
24	Control Panel Assembly	See Control Panel Assy. Drawing & Parts List Assy.	X	X	X	X	X	X	X	X
25	113-140	Bottom Mounting Bracket	X	X	X	X	X	X	X	X
26	135X123	Heat Shield	X	X	X	X	X	X	X	X
27	S153-218 ①	Disconnect Access Door	X	X	X	X	X	X	X	X
27	S153-387 ②	Disconnect Access Door	X	X	X	X	X	X	X	X
27	S153-405 ③	Disconnect Access Door	X	X	X	X	X	X	X	X
28	137-259	Fill Plate	X	X	X	X	X	X	X	X
29	113-149-* ①	Top Rain Flashing	X	X	X	X	X	X	X	X
29	113-360 ②	Top Rain Flashing	X	X	X	X	X	X	X	X
30	S553-524-* ①	Filter Door	X	X	X	X	X	X	X	X
30	S553-554 ②	Filter Door	X	X	X	X	X	X	X	X
30	S553-553 ③	Filter Door	X	X	X	X	X	X	X	X
31	S536-498	Cond. Partition Block Off Plate	X	X	X	X	X	X	X	X
33	135-329	Air Baffle	X	X	X	X	X	X	X	X

- ① Exterior cabinet parts are manufactured with various paint color options. To ensure that you receive the proper paint color, you must include the complete model and serial number of the unit for which cabinet parts are being ordered.
- ② Note: Exterior cabinet parts are manufactured for Code "A" aluminum cabinets
- ③ Note: Exterior cabinet parts are manufactured for Code "S" stainless steel cabinets

FUNCTIONAL COMPONENTS

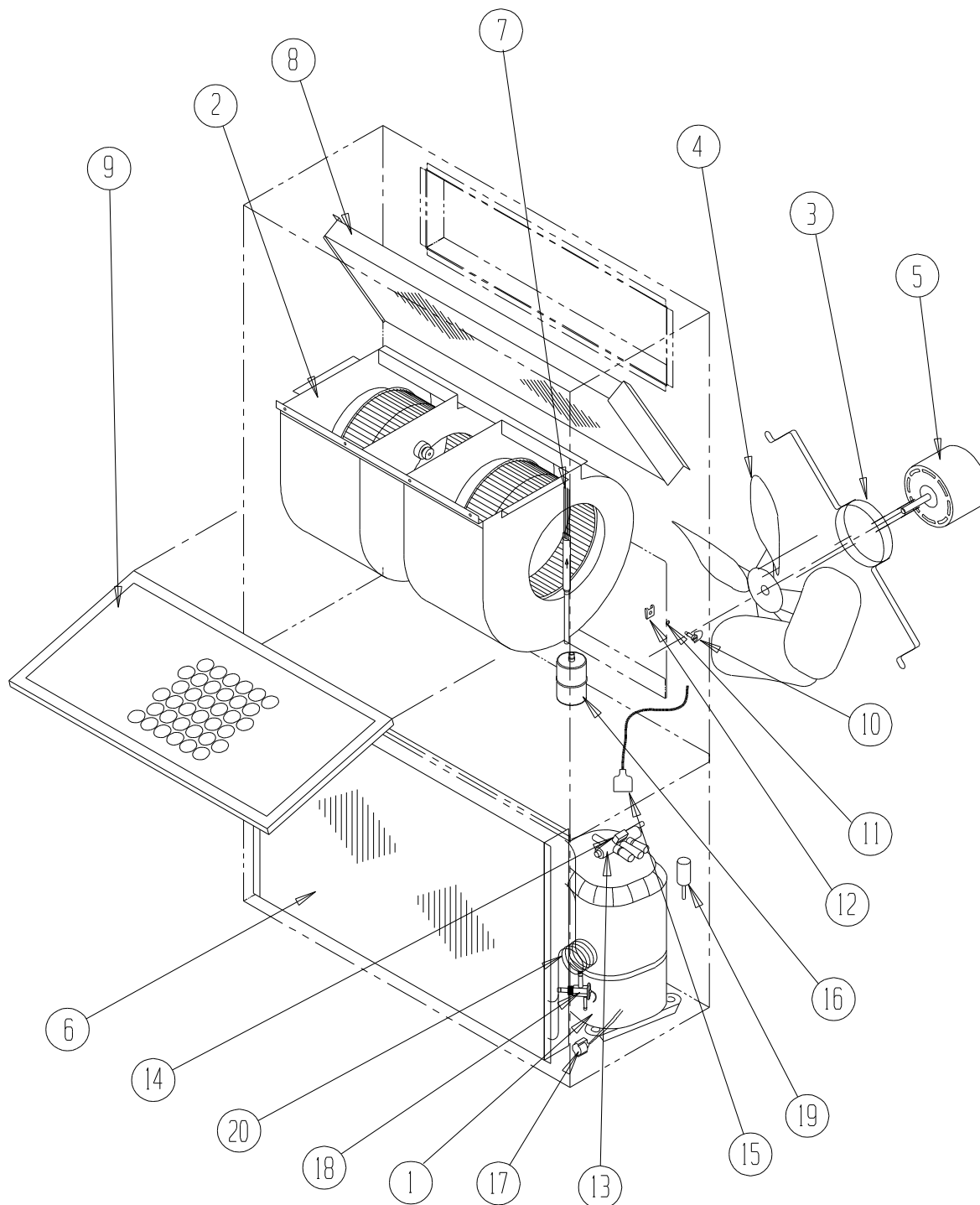

SEXP-529

FUNCTIONAL COMPONENTS

Dwg No.	Part Number	Description	W30H2-A	W30H2-B	W30H2-C	W36H2-A	W36H2-B	W36H2-C
1	8000-298	Compressor	X					
1	8000-299	Compressor		X				
1	8000-300	Compressor			X			
1	8000-309	Compressor				X		
1	8000-310	Compressor					X	
1	8000-311	Compressor						X
2	S900-231	Blower Assembly	X	X		X	X	
2	S900-232	Blower Assembly			X			X
3	8200-001	Fan Motor Mount	X	X	X	X	X	X
4	5151-045	Fan Blade	X	X	X	X	X	X
5	8103-013	Condenser Motor	X	X		X	X	
5	8103-020	Condenser Motor			X			X
6	5051-112BX	Condenser Coil				X	X	X
6	5051-157BX	Condenser Coil	X	X	X			
7	800-0649	Cooling Distributor Assembly				X	X	X
7	800-0648	Cooling Distributor Assembly	X	X	X			
8	5060-064BX	Evaporator Coil	X	X	X			
8	5060-136BX	Evaporator Coil				X	X	X
9	7004-019	Air Filter 1" Throw-Away	X	X	X	X	X	X
9	7003-031	Air Filter 1" Washable ①	X	X	X	X	X	X
9	7004-026	Air Filter 2" Pleated ①	X	X	X	X	X	X
10	1171-022	1/4" Turn Fastener	X	X	X	X	X	X
11	1171-024	1/4" Turn Retainer	X	X	X	X	X	X
12	1171-023	1/4" Receptacle	X	X	X	X	X	X
13	5650-039	Reversing Valve with 24V Solenoid Coil	X	X	X	X	X	X
14	5650-042	Rev. Valve Solenoid, Red Casing (Ranco)	X	X	X	X	X	X
14	5650-043	Rev. Valve Solenoid, Black Casing (Wilspec)	X	X	X	X	X	X
14	5650-046	Rev. Valve Solenoid, Black Casing (San Hua)	X	X	X	X	X	X
15	5650-037	Molded Plug 36" Lead	X	X	X	X	X	X
16	5201-009	Filter Drier	X	X	X	X	X	X
17	8620-224	Defrost Sensor	X	X	X	X	X	X
18	5651-177	Heating TXV Thermal Expansion Valve	X	X	X	X	X	X
19	1804-0462	High Pressure Switch (Flare) ①	X	X	X	X	X	X
20	800-0378	Heating Distributor Assembly				X	X	X
20	800-0379	Heating Distributor Assembly	X	X	X			
NS	1804-0107	Low Pressure Switch (Flare) ①	X	X	X	X	X	X
NS	CMA-28	Low Ambient Control (Flare) ①	X	X	X	X	X	X
NS	3000-1276	Compressor Wire Harness	X			X		
NS	3000-1244	Compressor Wire Harness		X	X		X	X

NS = Not Shown

① = Optional

FUNCTIONAL COMPONENTS – DEHUM. MODELS

Dwg No.	Part Number	Description	W30H2DA	W30H2DB	W30H2DC	W36H2DA	W36H2DB	W36H2DC
1	8000-298	Compressor	X					
1	8000-299	Compressor		X				
1	8000-300	Compressor			X			
1	8000-309	Compressor				X		
1	8000-310	Compressor					X	
1	8000-311	Compressor						X
2	S900-231	Blower Assembly	X	X		X	X	
2	S900-232	Blower Assembly			X			X
3	8200-001	Fan Motor Mount	X	X	X	X	X	X
4	5151-045	Fan Blade	X	X	X	X	X	X
5	8103-013	Condenser Motor	X	X		X	X	
5	8103-020	Condenser Motor			X			X
6	5051-112BX	Condenser Coil				X	X	X
6	5051-157BX	Condenser Coil	X	X	X			
7	5651-174	Cooling Expansion Valve	X	X	X	X	X	X
7	800-0392	Cooling Distributor Assembly	X	X	X			
7	800-0393	Cooling Distributor Assembly				X	X	X
8	917-0043BX	Evaporator Coil Assembly	X	X	X			
8	917-0123BX	Evaporator Coil Assembly				X	X	X
9	7004-019	Air Filter 1" Throw-Away	X	X	X	X	X	X
9	7003-031	Air Filter 1" Washable ①	X	X	X	X	X	X
9	7004-026	Air Filter 2" Pleated ①	X	X	X	X	X	X
10	1171-022	1/4" Turn Fastener	X	X	X	X	X	X
11	1171-024	1/4" Turn Retainer	X	X	X	X	X	X
12	1171-023	1/4" Receptacle	X	X	X	X	X	X
13	5650-039	Reversing Valve with 24V Solenoid Coil	X	X	X	X	X	X
14	5650-042	Rev. Valve Solenoid, Red Casing (Ranco)	X	X	X	X	X	X
14	5650-043	Rev. Valve Solenoid, Black Casing (Wilspec)	X	X	X	X	X	X
14	5650-046	Rev. Valve Solenoid, Black Casing (San Hua)	X	X	X	X	X	X
15	5650-037	Molded Plug 36" Lead	X	X	X	X	X	X
16	5201-009	Filter Drier	X	X	X	X	X	X
17	8620-224	Defrost Sensor	X	X	X	X	X	X
18	5651-191	Heating TXV Thermal Expansion Valve 	X	X	X	X	X	X
19	1804-0462	High Pressure Switch (Flare) ①	X	X	X	X	X	X
20	800-0378	Heating Distributor Assembly				X	X	X
20	800-0186	Heating Distributor Assembly	X	X	X			
NS	3000-1276	Compressor Wire Harness	X			X		
NS	3000-1244	Compressor Wire Harness		X	X		X	X
NS	5651-146	Check Valve	X	X	X	X	X	X
NS	1804-0107	Low Pressure Switch (Flare) ①	X	X	X	X	X	X
NS	CMA-28	Low Ambient Control (Flare) ①	X	X	X	X	X	X
NS	5650-042	Rev. Valve Solenoid, Red Casing (Ranco)	X	X	X	X	X	X
NS	5650-046	Rev. Valve Solenoid, Black Casing (San Hua)	X	X	X	X	X	X
NS	5650-045	3-Way Valve with 24V Solenoid Coil	X	X	X	X	X	X
NS	5650-043	Flow Control (Orifice)	X	X	X	X	X	X

NS = Not Shown

① = Optional

CONTROL PANEL COMPONENTS

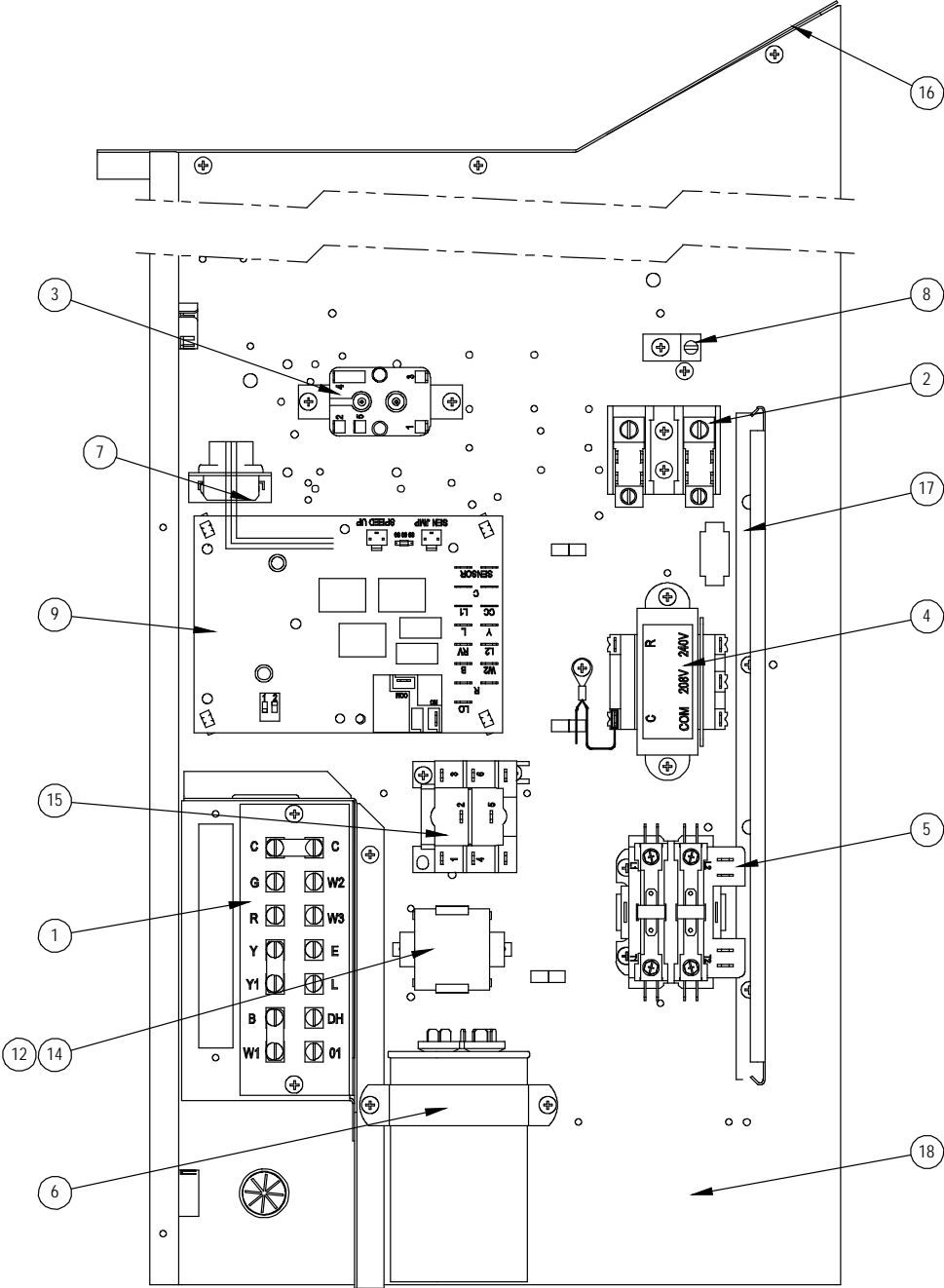

SEXP-530 A

CONTROL PANEL COMPONENTS

Dwg No.	Part Number	Description	W30H2-A	W30H2-B	W30H2-C	W36H2-A	W36H2-B	W36H2-C
1	8607-019	Low Voltage Terminal Strip	X	X	X	X	X	X
2	8607-013	Terminal Block 2 Pole	X			X		
2	8607-014	Terminal Block 3 Pole		X	X		X	X
2	8607-015	Phenolic Insulator			X			X
3	8201-009	Blower Control Relay	X	X		X	X	
3	8201-032	Blower Control Relay			X			X
4	8407-035	Transformer	X	X		X	X	
4	8407-042	Transformer			X			X
5	8401-007	Compressor Contactor	X			X		
5	8401-002	Compressor Contactor		X	X		X	X
6	8552-052	Compressor Capacitor	X			X		
6	8552-002	Outdoor Motor Capacitor		X	X		X	X
7	3000-1284	Wire Assembly	X	X	X	X	X	X
8	8611-006	Ground Terminal	X	X	X	X	X	X
9	8620-223	Heat Pump Control Board	X	X	X	X	X	X
12	8201-086	Low Ambient Bypass Relay ①	X	X	X	X	X	X
14	8551-004	Start Device (PTCR) ①	X			X		
15	8201-032	Outdoor Fan Relay			X			X
16	117X137	Control Panel Top	X	X	X	X	X	X
17	135-122	Wire Shield	X	X	X	X	X	X
18	117X232	Control Panel	X	X	X	X	X	X
NS	4096-140	Wiring Diagram	X			X		
NS	4096-242	Wiring Diagram		X			X	
NS	4096-341	Wiring Diagram			X			X
NS	8201-126	3-Phase Line Monitor		X	X		X	X
NS	CMH-14A	ODT Kit	X	X	X	X	X	X
NS	8615-038	Circuit Breaker 35A 2-Pole	X					
NS	8615-051	Circuit Breaker 25A 3-Pole		X				
NS	8615-067	460V 40A Toggle Disconnect			X			X
NS	8615-055	Circuit Breaker 40A 2-Pole				X		
NS	8615-051	Circuit Breaker 25A 3-Pole					X	

NS = Not Shown

① = Optional

CONTROL PANEL COMPONENTS

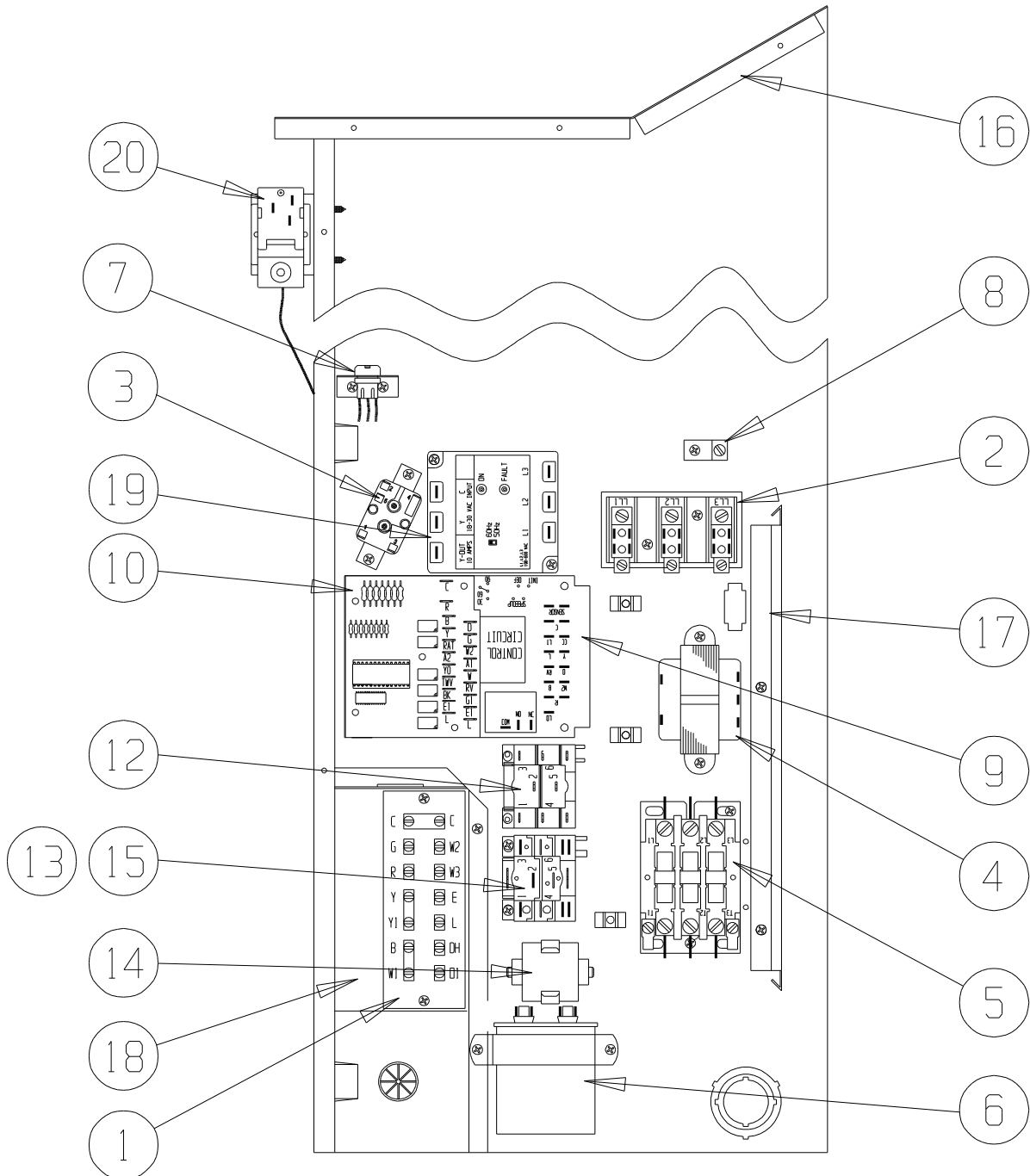

SEXP-542

CONTROL PANEL COMPONENTS – DEHUM. MODELS

Dwg No.	Part Number	Description	W30H2DA	W30H2DB	W30H2DC	W36H2DA	W36H2DB	W36H2DC
1	8607-019	Low Voltage Terminal Strip	X	X	X	X	X	X
2	8607-013	Terminal Block 2 Pole	X			X		
2	8607-014	Terminal Block 3 Pole		X	X		X	X
2	8607-015	Phenolic Insulator			X			X
3	8201-009	Blower Control Relay			X			X
3	8201-032	Blower Control Relay	X	X		X	X	
4	8407-048	Transformer 65VA	X	X		X	X	
4	8407-050	Transformer 65VA			X			X
5	8401-007	Compressor Contactor	X			X		
5	8401-002	Compressor Contactor		X	X		X	X
6	8552-052	Compressor Capacitor	X			X		
6	8552-002	Outdoor Motor Capacitor		X	X		X	X
7	3000-1285	6-Pin Wire Assembly	X	X	X	X	X	X
8	8611-006	Ground Terminal	X	X	X	X	X	X
9	8620-223	Heat Pump Control Board	X	X	X	X	X	X
10	8201-113	Dehumidification Logic Board ①	X	X	X	X	X	X
12	8201-086	Low Ambient Bypass Relay ①	X	X	X	X	X	X
13	8607-017	LAC Terminal Block ①	X	X	X	X	X	X
14	8551-004	Start Device (PTCR) ①	X			X		
15	8201-032	Outdoor Fan Relay			X			X
16	117X137	Control Panel Top	X	X	X	X	X	X
17	135-122	Wire Shield	X	X	X	X	X	X
18	117X232	Control Panel	X	X	X	X	X	X
19	8201-126	3-Phase Line Monitor		X	X		X	X
20	8408-037	Return Air Thermostat	X	X	X	X	X	X
NS	4096-143	Wiring Diagram	X			X		
NS	4096-244	Wiring Diagram		X			X	
NS	4096-342	Wiring Diagram			X			X
NS	CMH-14A	ODT Kit	X	X	X	X	X	X
NS	8615-038	Circuit Breaker 35A 2-Pole	X					
NS	8615-051	Circuit Breaker 25A 3-Pole		X				
NS	8615-067	460V 40A Toggle Disconnect			X			X
NS	8615-055	Circuit Breaker 40A 2-Pole				X		
NS	8615-051	Circuit Breaker 25A 3-Pole					X	

NS = Not Shown

① = Optional

BLOWER ASSEMBLY

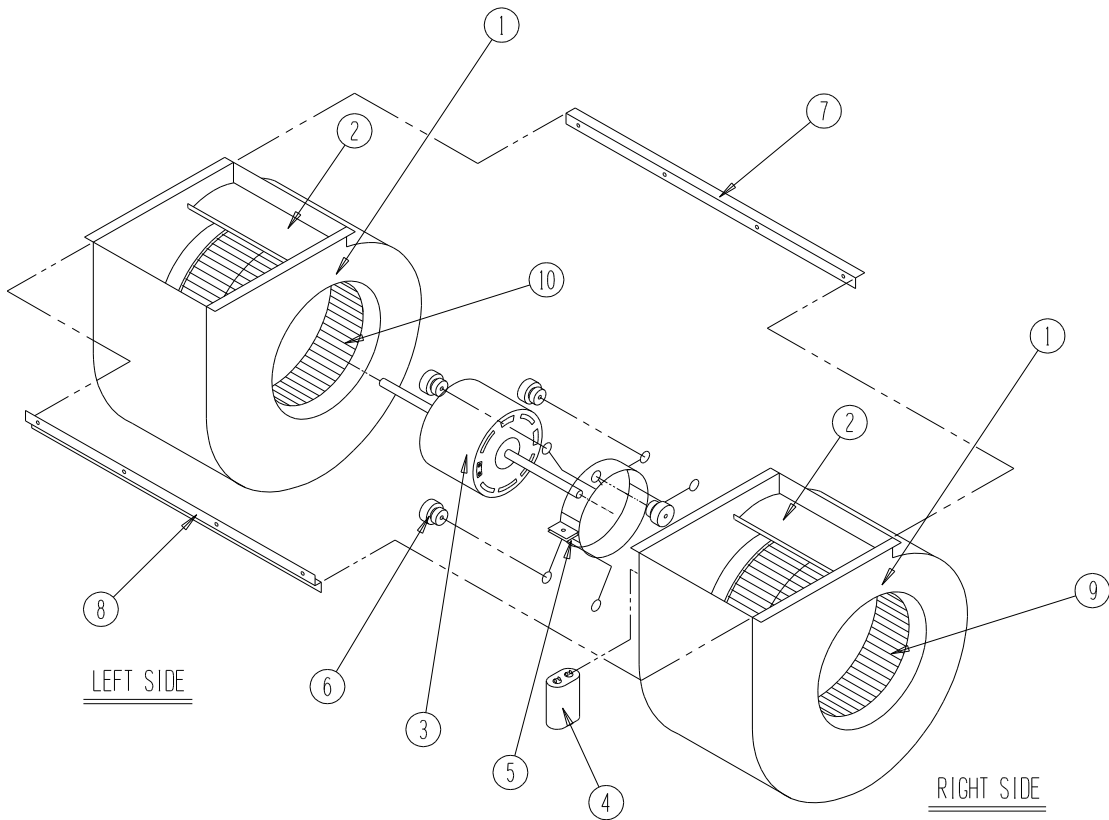

SEXP-346

Dwg No.	Part Number	Description	S900-231	S900-232
1	151-111	Blower Housing	2	2
2	144-174	Diffuser	2	2
3	8105-029	Blower Motor (230/208)	X	
3	8105-033	Blower Motor (460)		X
4	8552-002	Capacitor	X	X
5	8200-031	Motor Mount	X	X
6	5451-011	Grommets	6	6
7	105-870	Back Brace	X	X
8	103-401	Front Brace	X	X
9	5152-090	Wheel CW	X	X
10	5152-091	Wheel CCW	X	X