

---

# REPLACEMENT PARTS MANUAL

---

## WALL MOUNTED PACKAGED HEAT PUMPS

Models:

W42H2-A	W42H2DA	W48H2-A	W48H2DA	W60H2-A	W60H2DA
W42H2-B	W42H2DB	W48H2-B	W48H2DB	W60H2-B	W60H2DB
W42H2-C	W42H2DC	W48H2-C	W48H2DC	W60H2-C	W60H2DC

---

### General Notes

- Revised and/or additional pages may be issued from time to time.
- A complete and current manual consists of pages shown in the following contents section.

### Important

- Contact the installing and/or local Bard distributor for all parts requirements. Be sure to have the complete model and serial number available from the unit rating plate.

### Contents

Description	Page
Cabinet Components	
♦ Exploded View .....	2
♦ Usage List .....	3
♦ Usage List .....	4
Functional Components	
♦ Exploded View .....	6
♦ Usage List .....	7
♦ Usage List – Dehum. ....	8
Control Panel Components	
♦ Layout View .....	10
♦ Usage List .....	11
Control Panel Components – Dehum. Models	
♦ Layout View .....	12
♦ Usage List .....	13
Blower Housing	
♦ Exploded View .....	14
♦ Usage List .....	14



Bard Manufacturing Company, Inc.  
Bryan, Ohio 43506  
[www.bardhvac.com](http://www.bardhvac.com)

Manual: 2110-597H  
Supersedes: 2110-597G  
Date: 6-23-16

# CABINET COMPONENTS

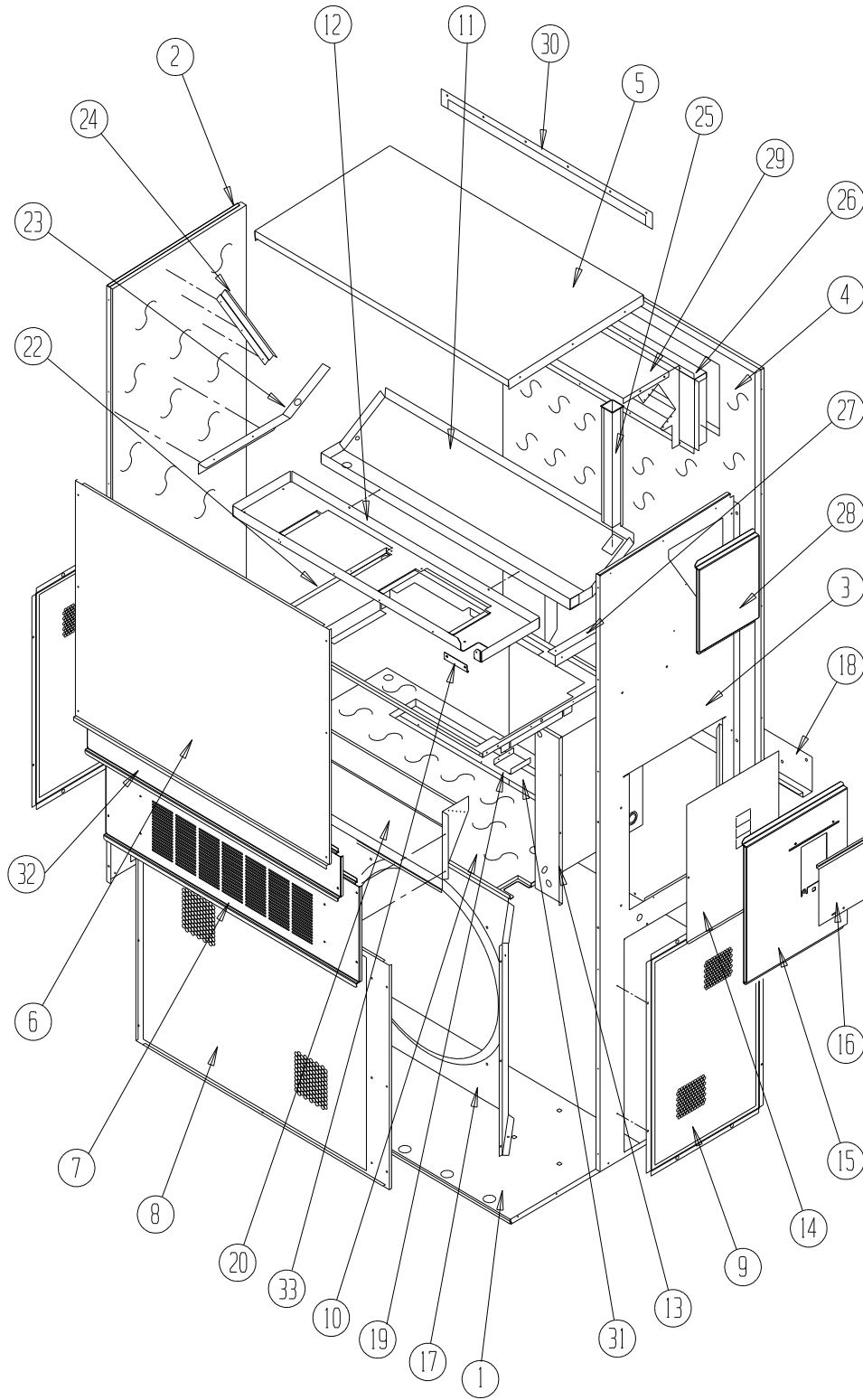

SEXP-658 A

This drawing is referenced in tables on pages 3 and 4

# CABINET COMPONENTS

Dwg No.	Part Number	Description	W42H2-A, -B	W42H2-C	W42H2DA, B	W42H2DC	W48H2-A, -B	W48H2-C	W48H2DA, B	W48H2DC
1	S127-425	Lower Base	X	X	X	X	X	X	X	X
1	S127-430 ③	Lower Base	X	X	X	X	X	X	X	X
2	S501-686-* ①	Left Side	X	X	X	X	X	X	X	X
2	S501-699 ②	Left Side	X	X	X	X	X	X	X	X
2	S501-701 ③	Left Side	X	X	X	X	X	X	X	X
3	S501-677-* ①	Right Side	X	X	X	X	X	X	X	X
3	S501-698 ②	Right Side	X	X	X	X	X	X	X	X
3	S501-700 ③	Right Side	X	X	X	X	X	X	X	X
4	S508-098	Back	X	X	X	X	X	X	X	X
4	S508-275 ②	Back	X	X	X	X	X	X	X	X
4	S508-221 ③	Back	X	X	X	X	X	X	X	X
5	S507-307-* ①	Top	X	X	X	X	X	X	X	X
5	S507-309 ②	Top	X	X	X	X	X	X	X	X
5	S507-310 ③	Top	X	X	X	X	X	X	X	X
6	S515-230-* ①	Upper Front	X	X	X	X	X	X	X	X
6	S514-231 ②	Upper Front	X	X	X	X	X	X	X	X
6	S514-232 ③	Upper Front	X	X	X	X	X	X	X	X
7	S553-522-* ①	Vent Option Door	X	X	X	X	X	X	X	X
7	S553-529-* ①	Vent Option Door with ERV	X	X	X	X	X	X	X	X
7	S553-525 ②	Vent Option Door	X	X	X	X	X	X	X	X
7	S553-527 ③	Vent Option Door	X	X	X	X	X	X	X	X
8	118-048-* ①	Condenser Grille	X	X	X	X	X	X	X	X
8	118-064 ②	Condenser Grille	X	X	X	X	X	X	X	X
8	118-072 ③	Condenser Grille	X	X	X	X	X	X	X	X
9	118-057-* ①	Side Grille	2	2	2	2	2	2	2	2
9	118-063 ②	Side Grille	2	2	2	2	2	2	2	2
9	118-073 ③	Side Grille	2	2	2	2	2	2	2	2
10	S521X258	Condenser Partition	X	X	X	X	X	X	X	X
11	S123-122	Drain Pan	X	X	X	X	X	X	X	X
11	S123-125 ②③	Drain Pan	X	X	X	X	X	X	X	X
12	121X216	Blower Partition	X	X	X	X	X	X	X	X
13	Control Panel Assy.	See Control Panel Assy. Drawing & Parts List	X	X	X	X	X	X	X	X
14	S132-114	Control Panel Cover (Inner)	X		X		X		X	
14	S132-171	Control Panel Cover (Inner)		X		X		X		X
15	S533-225-* ①	Control Panel Cover (Outer)	X	X	X	X	X	X	X	X
15	S533-229 ②	Control Panel Cover (Outer)	X	X	X	X	X	X	X	X
15	S533-230 ③	Control Panel Cover (Outer)	X	X	X	X	X	X	X	X
16	S153-218-* ①	Disconnect Access Door	X	X	X	X	X	X	X	X
16	S153-387 ②	Disconnect Access Door	X	X	X	X	X	X	X	X
16	S153-405 ③	Disconnect Access Door	X	X	X	X	X	X	X	X
17	125-024	Fan Shroud	X	X	X	X	X	X	X	X
17	125-058 ③	Fan Shroud	X	X	X	X	X	X	X	X
18	113-140	Bottom Mounting Bracket	X	X	X	X	X	X	X	X
19	137-209	Fill	X	X	X	X	X	X	X	X
20	BFAD-5	Fresh Air Damper Assembly	X	X	X	X	X	X	X	X
22	131X099	Filter Tray	X	X	X	X	X	X	X	X
23	105X877	Left Side Support	X	X	X	X	X	X	X	X
24	147-046	Left Evaporator Support	X	X	X	X	X	X	X	X
25	135-128	Raceway	2	2	2	2	2	2	2	2
26	S111X034	Outlet Air Frame Assembly	X	X	X	X	X	X	X	X
27	105X878	Right Side Support	X	X	X	X	X	X	X	X
28	S543-172-* ①	Right Side Cover Plate (Outer)	X	X	X	X	X	X	X	X
28	S543-176 ②	Right Side Cover Plate (Outer)	X	X	X	X	X	X	X	X
28	S543-177 ③	Right Side Cover Plate (Outer)	X	X	X	X	X	X	X	X
29	135-129	Heat Shield	X	X	X	X	X	X	X	X
30	113-150-* ①	Top Rain Flashing	X	X	X	X	X	X	X	X
30	113-359 ③	Top Rain Flashing	X	X	X	X	X	X	X	X
31	S536-258	Cond. Partition Block Off Plate	X	X	X	X	X	X	X	X
32	S553-521-* ①	Filter Door Assembly	X	X	X	X	X	X	X	X
32	S553-526 ②	Filter Door Assembly	X	X	X	X	X	X	X	X
32	S553-528 ③	Filter Door Assembly	X	X	X	X	X	X	X	X

① Exterior cabinet parts are manufactured with various paint color options. To ensure the proper paint color is received, please reference the following codes: Beige -X, White -1, Buckeye Gray -4, Desert Brown -5, Dark Bronze -8

② Exterior cabinet parts are manufactured from aluminum Code "A"

③ Exterior cabinet parts are manufactured from stainless steel Code "S"

# CABINET COMPONENTS

Dwg No.	Part Number	Description	W60H2-A, -B	W60H2-C	W60H2DA, B	W60H2DC
1	S127-425	Lower Base	X	X	X	X
1	S127-430 ③	Lower Base	X	X	X	X
2	S501-819-* ①	Left Side	X	X	X	X
2	S501-822 ②	Left Side	X	X	X	X
2	S501-820 ③	Left Side	X	X	X	X
3	S501-818-* ①	Right Side	X	X	X	X
3	S501-823 ②	Right Side	X	X	X	X
3	S501-821 ③	Right Side	X	X	X	X
4	S508-129	Back	X	X	X	X
4	S508-275 ②	Back	X	X	X	X
4	S508-221 ③	Back	X	X	X	X
5	S507-307-* ①	Top	X	X	X	X
5	S507-309 ②	Top	X	X	X	X
5	S507-310 ③	Top	X	X	X	X
6	S515-230-* ①	Upper Front	X	X	X	X
6	S514-231 ②	Upper Front	X	X	X	X
6	S514-232 ③	Upper Front	X	X	X	X
7	S553-522-* ①	Vent Option Door	X	X	X	X
7	S553-529-* ①	Vent Option Door with ERV	X	X	X	X
7	S553-525 ②	Vent Option Door	X	X	X	X
7	S553-527 ③	Vent Option Door	X	X	X	X
8	118-052-* ①	Condenser Grille	X	X	X	X
8	118-080 ②	Condenser Grille	X	X	X	X
8	118-078 ③	Condenser Grille	X	X	X	X
9	118-058-* ①	Side Grille	2	2	2	2
9	118-081 ②	Side Grille	2	2	2	2
9	118-079 ③	Side Grille	2	2	2	2
10	S521X258	Condenser Partition	X	X	X	X
11	S123-122	Drain Pan	X	X	X	X
11	S123-125 ②③	Drain Pan	X	X	X	X
12	121X216	Blower Partition	X	X	X	X
13	Control Panel Assy.	See Control Panel Assy. Drawing & Parts List	X	X	X	X
14	S132-114	Control Panel Cover (Inner)	X		X	
14	S132-171	Control Panel Cover (Inner)		X		X
15	S533-225-* ①	Control Panel Cover (Outer)	X	X	X	X
15	S533-229 ②	Control Panel Cover (Outer)	X	X	X	X
15	S533-230 ③	Control Panel Cover (Outer)	X	X	X	X
16	S153-218-* ①	Disconnect Access Door	X	X	X	X
16	S153-387 ②	Disconnect Access Door	X	X	X	X
16	S153-405 ③	Disconnect Access Door	X	X	X	X
17	125-029	Fan Shroud	X	X	X	X
17	125-059 ③	Fan Shroud	X	X	X	X
18	113-140	Bottom Mounting Bracket	X	X	X	X
19	137-209	Fill	X	X	X	X
20	BFAD-5	Fresh Air Damper Assembly	X	X	X	X
22	131X099	Filter Tray	X	X	X	X
23	105X877	Left Side Support	X	X	X	X
24	147-046	Left Evaporator Support	X	X	X	X
25	135-128	Raceway	2	2	2	2
26	S111X034	Outlet Air Frame Assembly	X	X	X	X
27	105X878	Right Side Support	X	X	X	X
28	S543-172-* ①	Right Side Cover Plate (Outer)	X	X	X	X
28	S543-176 ②	Right Side Cover Plate (Outer)	X	X	X	X
28	S543-177 ③	Right Side Cover Plate (Outer)	X	X	X	X
29	135-129	Heat Shield	X	X	X	X
30	113-150-* ①	Top Rain Flashing	X	X	X	X
30	113-359 ③	Top Rain Flashing	X	X	X	X
31	S536-258	Cond. Partition Block Off Plate	X	X	X	X
32	S553-521-* ①	Filter Door Assembly	X	X	X	X
32	S553-526 ②	Filter Door Assembly	X	X	X	X
32	S553-528 ③	Filter Door Assembly	X	X	X	X

① Exterior cabinet parts are manufactured with various paint color options. To ensure the proper paint color is received, please reference the following codes: Beige -X, White -1, Buckeye Gray -4, Desert Brown -5, Dark Bronze -8

② Exterior cabinet parts are manufactured from aluminum Code "A"

③ Exterior cabinet parts are manufactured from stainless steel Code "S"

*This page intentionally left blank.*

# FUNCTIONAL COMPONENTS

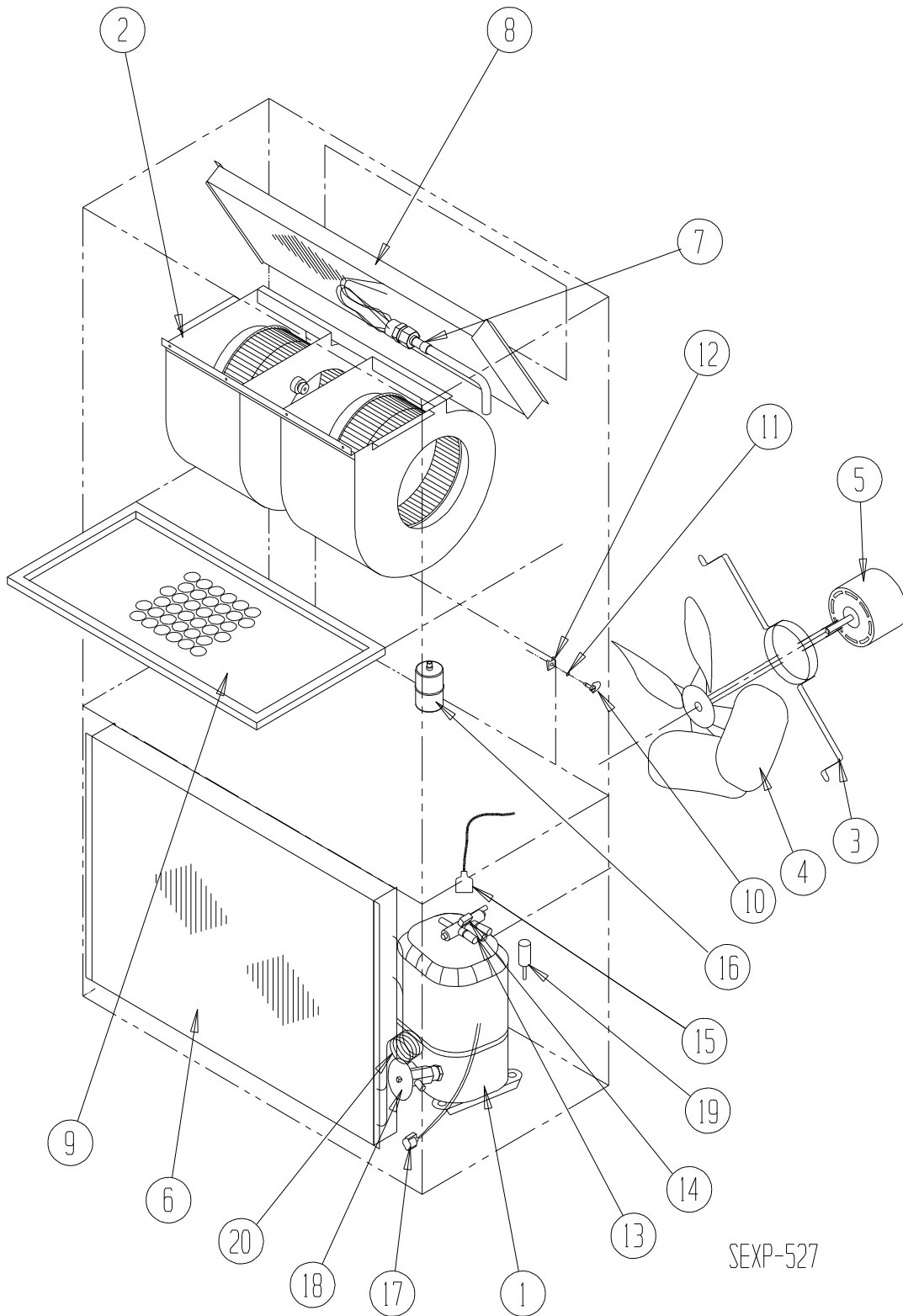

SEXP-527

This drawing is referenced in tables on pages 7 and 8

# FUNCTIONAL COMPONENTS

Dwg No.	Part No.	Description	W42H2-A	W42H2-B	W42H2-C	W48H2-A	W48H2-B	W48H2-C	W60H2-A	W60H2-B	W60H2-C
1	8000-332	Compressor	X								
1	8000-333	Compressor		X							
1	8000-334	Compressor			X						
1	8000-343	Compressor				X					
1	8000-344	Compressor					X				
1	8000-345	Compressor						X			
1	8000-324	Compressor							X		
1	8000-325	Compressor								X	
1	8000-326	Compressor									X
2	S900-183	Blower Assembly	X	X		X	X				
2	S900-184	Blower Assembly			X			X			
2	S900-185	Blower Assembly							X	X	
2	S900-186	Blower Assembly									X
3	8200-004	Fan Motor Mount	X	X	X	X	X	X	X	X	X
4	5151-060	Fan Blade	X	X	X	X	X	X	X	X	X
5	8105-039	Condenser Motor	X	X		X	X		X	X	
5	8105-030	Condenser Motor			X			X			X
6	5051-158BX	Condenser Coil	X	X	X	X	X	X			
6	5051-159BX	Condenser Coil							X	X	X
7	800-0382	Distributor Assembly	X	X	X						
7	800-0383	Distributor Assembly				X	X	X			
7	800-0375	Distributor Assembly							X	X	X
8	5060-137BX	Evaporator Coil	X	X	X						
8	5060-138BX	Evaporator Coil				X	X	X			
8	5060-082BX	Evaporator Coil							X	X	X
9	7004-016	Air Filter 1" Throw-Away	X	X	X	X	X	X	X	X	X
9	7003-030	Air Filter 1" Washable (Optional)	X	X	X	X	X	X	X	X	X
9	7004-027	Air Filter 2" Pleated (Optional)	X	X	X	X	X	X	X	X	X
10	1171-022	1/4 Turn Fastener	X	X	X	X	X	X	X	X	X
11	1171-024	1/4 Turn Retainer	X	X	X	X	X	X	X	X	X
12	1171-023	1/4 Receptacle	X	X	X	X	X	X	X	X	X
13	5650-039	Reversing Valve with 24V Solenoid Coil	X	X	X						
13	5650-040	Reversing Valve with 24V Solenoid Coil				X	X	X	X	X	X
14	5650-042	Rev. Valve Solenoid, Red Casing (Ranco)	X	X	X	X	X	X	X	X	X
14	5650-043	Rev. Valve Solenoid, Black Casing (Wilspec)	X	X	X	X	X	X	X	X	X
14	5650-046	Rev. Valve Solenoid, Black Casing (San Hua)	X	X	X	X	X	X	X	X	X
15	5650-037	Molded Plug 36" Lead	X	X	X	X	X	X	X	X	X
16	5201-010	Filter Drier	X	X	X	X	X	X	X	X	X
17	8620-224	Defrost Sensor	X	X	X	X	X	X	X	X	X
18	5651-178	Heating TXV Thermal Expansion Valve	X	X	X	X	X	X			
18	5651-190	Heating TXV Thermal Expansion Valve							X	X	X
19	1804-0462	High Pressure Switch (Flare) (Optional)	X	X	X	X	X	X	X	X	X
20	800-0381	Heating Distributor Assembly	X	X	X	X	X	X			
20	800-0376	Heating Distributor Assembly							X	X	X
NS	1804-0107	Low Pressure Switch (Flare) (Optional)	X	X	X	X	X	X	X	X	X
NS	CMA-28	Low Ambient Control (Flare) (Optional)	X	X	X	X	X	X	X	X	X

NS = Not Shown

# FUNCTIONAL COMPONENTS – DEHUM. MODELS

Dwg No.	Part No.	Description	W42H2DA	W42H2DB	W42H2DC	W48H2DA	W48H2DB	W48H2DC	W60H2DA	W60H2DB	W60H2DC
1	8000-332	Compressor	X								
1	8000-333	Compressor		X							
1	8000-334	Compressor			X						
1	8000-343	Compressor				X					
1	8000-344	Compressor					X				
1	8000-345	Compressor						X			
1	8000-324	Compressor							X		
1	8000-325	Compressor								X	
1	8000-326	Compressor									X
2	S900-183	Blower Assembly	X	X		X	X				
2	S900-184	Blower Assembly			X			X			
2	S900-185	Blower Assembly							X	X	
2	S900-186	Blower Assembly									X
3	8200-004	Fan Motor Mount	X	X	X	X	X	X	X	X	X
4	5151-060	Fan Blade	X	X	X	X	X	X	X	X	X
5	8105-039	Condenser Motor	X	X		X	X		X	X	
5	8105-030	Condenser Motor			X			X			X
6	5051-158BX	Condenser Coil	X	X	X	X	X	X			
6	5051-159BX	Condenser Coil							X	X	X
7	5651-211	Cooling Expansion Valve	X	X	X						
7	800-0292	Cooling Distributor Assembly	X	X	X						
7	5651-228	Cooling Expansion Valve				X	X	X			
7	800-0342	Cooling Distributor Assembly				X	X	X			
7	5651-241	Cooling Expansion Valve							X	X	X
7	800-0388	Cooling Distributor Assembly							X	X	X
8	917-0128BX	Evaporator Coil Assembly	X	X	X						
8	917-0130BX	Evaporator Coil Assembly				X	X	X			
8	917-0044BX	Evaporator Coil Assembly							X	X	X
9	7004-016	Air Filter 1" Throw-Away	X	X	X	X	X	X	X	X	X
9	7003-030	Air Filter 1" Washable (Optional)	X	X	X	X	X	X	X	X	X
9	7004-027	Air Filter 2" Pleated (Optional)	X	X	X	X	X	X	X	X	X
10	1171-022	1/4 Turn Fastener	X	X	X	X	X	X	X	X	X
11	1171-024	1/4 Turn Retainer	X	X	X	X	X	X	X	X	X
12	1171-023	1/4 Receptacle	X	X	X	X	X	X	X	X	X
13	5650-039	Reversing Valve with 24V Solenoid Coil	X	X	X						
13	5650-040	Reversing Valve with 24V Solenoid Coil				X	X	X	X	X	X
14	5650-042	Rev. Valve Solenoid, Red Casing (Ranco)	X	X	X	X	X	X	X	X	X
14	5650-043	Rev. Valve Solenoid, Black Casing (Wilspec)	X	X	X	X	X	X	X	X	X
14	5650-046	Rev. Valve Solenoid, Black Casing (San Hua)	X	X	X	X	X	X	X	X	X
15	5650-037	Molded Plug 36" Lead	X	X	X	X	X	X	X	X	X
16	5201-010	Filter Drier	X	X	X	X	X	X	X	X	X
17	8620-224	Defrost Sensor	X	X	X	X	X	X	X	X	X
18	5651-178	Heating TXV Thermal Expansion Valve	X	X	X	X	X	X			
18	5651-190	Heating TXV Thermal Expansion Valve							X	X	X
19	1804-0462	High Pressure Switch (Flare) (Optional)	X	X	X	X	X	X	X	X	X
20	800-0381	Heating Distributor Assembly	X	X	X	X	X	X			
20	800-0376	Heating Distributor Assembly							X	X	X
NS	1804-0107	Low Pressure Switch (Flare) (Optional)	X	X	X	X	X	X	X	X	X
NS	CMA-28	Low Ambient Control (Flare) (Optional)	X	X	X	X	X	X	X	X	X
NS	5650-042	Rev. Valve Solenoid, Red Casing (Ranco)	X	X	X	X	X	X	X	X	X
NS	5650-046	Rev. Valve Solenoid, Black Casing (San Hua)	X	X	X	X	X	X	X	X	X
NS	5650-045	3-Way Valve with 24V Solenoid Coil	X	X	X	X	X	X	X	X	X
NS	5650-043	Flow Control (Orifice)	X	X	X	X	X	X	X	X	X

NS = Not Shown



*This page intentionally left blank.*

# CONTROL PANEL COMPONENTS

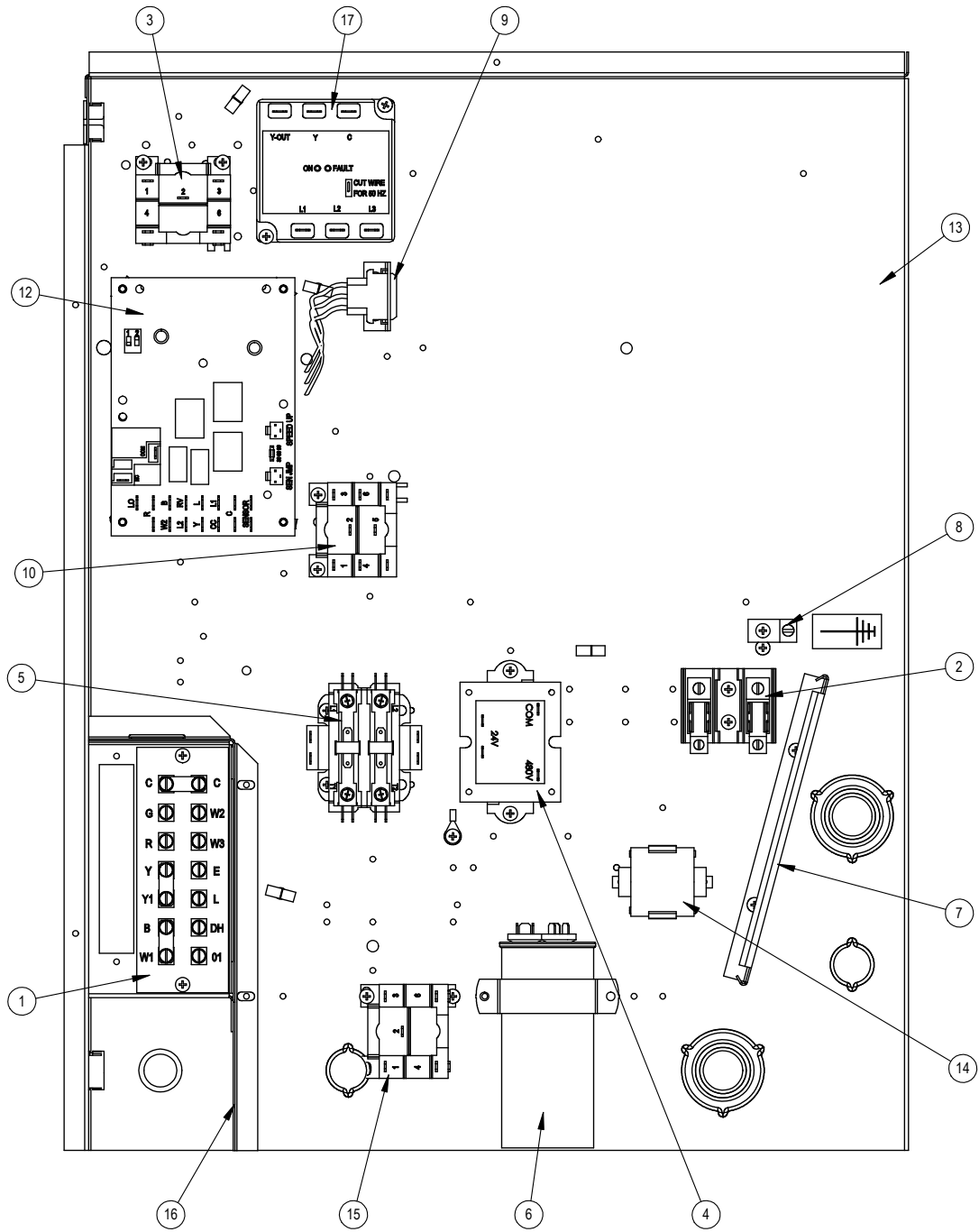

SEXP-709 A

# CONTROL PANEL COMPONENTS

Dwg No.	Part Number	Description	W42H2-A	W42H2-B	W42H2-C	W48H2-A	W48H2-B	W48H2-C	W60H2-A	W60H2-B	W60H2-C
1	8607-019	Low Voltage Terminal Strip	X	X	X	X	X	X	X	X	X
2	8607-013	Terminal Block 2 Pole	X			X			X		
2	8607-014	Terminal Block 3 Pole		X	X		X	X		X	X
2	8607-015	Phenolic Insulator		X			X			X	
3	8201-009	Blower Control Relay	X	X		X	X		X	X	
3	8201-032	Blower Control Relay			X			X			X
4	8407-035	Transformer	X	X		X	X		X	X	
4	8407-042	Transformer			X			X			X
5	8401-025	Compressor Contactor	X			X			X		
5	8401-002	Compressor Contactor		X	X		X	X		X	X
6	8552-089	Compressor Capacitor	X								
6	8552-005	Outdoor Motor Capacitor		X			X			X	
6	8552-026	Outdoor Motor Capacitor			X			X			X
6	8552-089	Compressor Capacitor				X					
6	8552-058	Compressor Capacitor							X		
7	135-130	Wire Shield	X	X	X	X	X	X	X	X	X
8	8611-006	Ground Terminal	X	X	X	X	X	X	X	X	X
9	3000-1282	Wire Assembly	X	X	X	X	X	X	X	X	X
10	8201-086	Low Ambient Bypass Relay ①	X	X	X	X	X	X	X	X	X
12	8620-223	Heat Pump Control Board	X	X	X	X	X	X	X	X	X
13	117X340	Control Panel	X	X	X	X	X	X	X	X	X
14	8551-004	Start Device (PTCR) ①	X			X			X		
15	8201-032	Outdoor Fan Relay			X			X			X
16	117X139	Low Voltage Box	X	X	X	X	X	X	X	X	X
17	8201-126	Phase Monitor		X	X		X	X		X	X
NS	3000-1222	Compressor Wire Harness	X			X			X		
NS	3000-1231	Compressor Wire Harness		X	X		X	X		X	X
NS	8615-040	Circuit Breaker 50A 2 Pole ②	X			X					
NS	8615-042	Circuit Breaker 35A 3 Pole ②		X			X				
NS	8615-041	Circuit Breaker 50A 2 Pole ②							X		
NS	8615-043	Circuit Breaker 35A 3 Pole ②								X	
NS	8615-067	Toggle Disconnect ②			X			X			X
NS	4096-139	Wiring Diagram	X			X			X		
NS	4096-240	Wiring Diagram		X			X			X	
NS	4096-339	Wiring Diagram			X			X			X

NS = Not Shown

① = Optional on these models

② = Circuit breakers listed are for units without electric heat "OZ" models.

# CONTROL PANEL COMPONENTS – DEHUM. MODELS

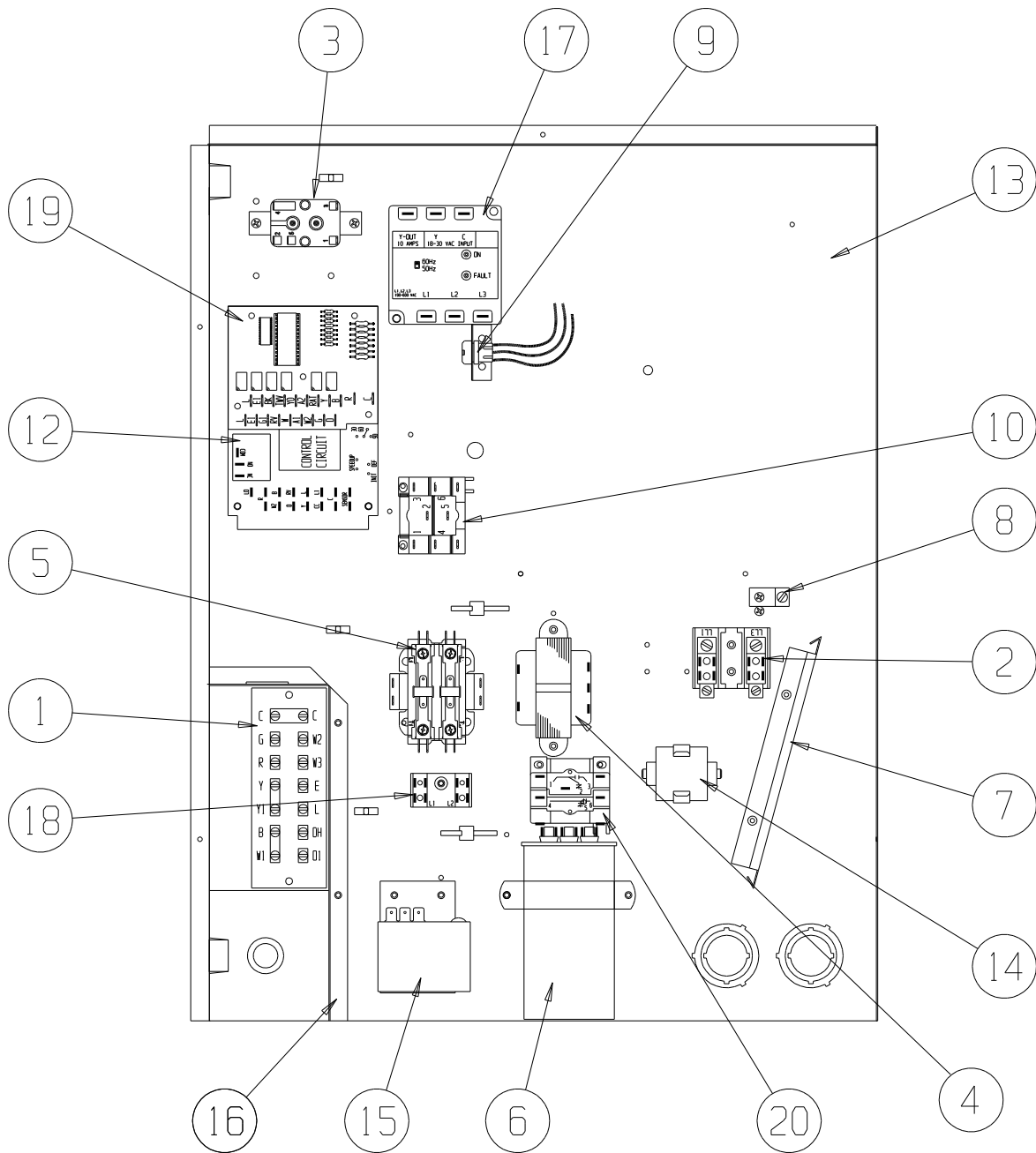

SEXP-710 A

## CONTROL PANEL COMPONENTS – DEHUM. MODELS

Dwg No.	Part Number	Description	W42H2DA	W42H2DB	W42H2DC	W48H2DA	W48H2DB	W48H2DC	W60H2DA	W60H2DB	W60H2DC
1	8607-019	Low Voltage Terminal Strip	X	X	X	X	X	X	X	X	X
2	8607-013	Terminal Block 2 Pole	X			X			X		
2	8607-014	Terminal Block 3 Pole		X	X		X	X		X	X
2	8607-015	Phenolic Insulator			X			X			X
3	8201-009	Blower Control Relay	X	X		X	X		X	X	
3	8201-032	Blower Control Relay			X			X			X
4	8407-065	Transformer 75VA	X	X		X	X		X	X	
4	8407-050	Transformer 75VA			X			X			X
5	8401-025	Compressor Contactor	X			X			X		
5	8401-002	Compressor Contactor		X	X		X	X		X	X
6	8552-089	Compressor Capacitor	X								
6	8552-005	Outdoor Motor Capacitor		X			X			X	
6	8552-026	Outdoor Motor Capacitor			X			X			X
6	8552-089	Compressor Capacitor				X					
6	8552-058	Compressor Capacitor							X		
7	135-130	Wire Shield	X	X	X	X	X	X	X	X	X
8	8611-006	Ground Terminal	X	X	X	X	X	X	X	X	X
9	3000-1167	Wire Harness	X	X	X	X	X	X	X	X	X
10	8201-086	Low Ambient Bypass Relay ①	X	X	X	X	X	X	X	X	X
12	8620-223	Heat Pump Control Board	X	X	X	X	X	X	X	X	X
13	117X340	Control Panel	X	X	X	X	X	X	X	X	X
14	8551-004	Start Device (PTCR) ①	X			X			X		
15	8408-037	Return Air Thermostat	X	X	X	X	X	X	X	X	X
16	117X139	Low Voltage Box	X	X	X	X	X	X	X	X	X
17	8201-126	Phase Monitor		X	X		X	X		X	X
18	8607-017	Terminal Block ①	X	X	X	X	X	X	X	X	X
19	8201-113	Dehumidification Logic Board	X	X	X	X	X	X	X	X	X
20	8201-032	Outdoor Fan Relay			X			X			X
NS	3000-1222	Compressor Wire Harness	X			X			X		
NS	3000-1231	Compressor Wire Harness		X	X		X	X		X	X
NS	8615-040	Circuit Breaker 50A 2 Pole ②	X			X					
NS	8615-042	Circuit Breaker 35A 3 Pole ②		X			X				
NS	8615-041	Circuit Breaker 50A 2 Pole ②							X		
NS	8615-043	Circuit Breaker 35A 3 Pole ②								X	
NS	8615-067	Toggle Disconnect ②			X			X			X
NS	4096-143	Wiring Diagram	X			X			X		
NS	4096-244	Wiring Diagram		X			X			X	
NS	4096-342	Wiring Diagram			X			X			X

NS = Not Shown

① = Optional on these models

② = Circuit breakers listed are for units without electric heat "OZ" models.

# BLOWER ASSEMBLY

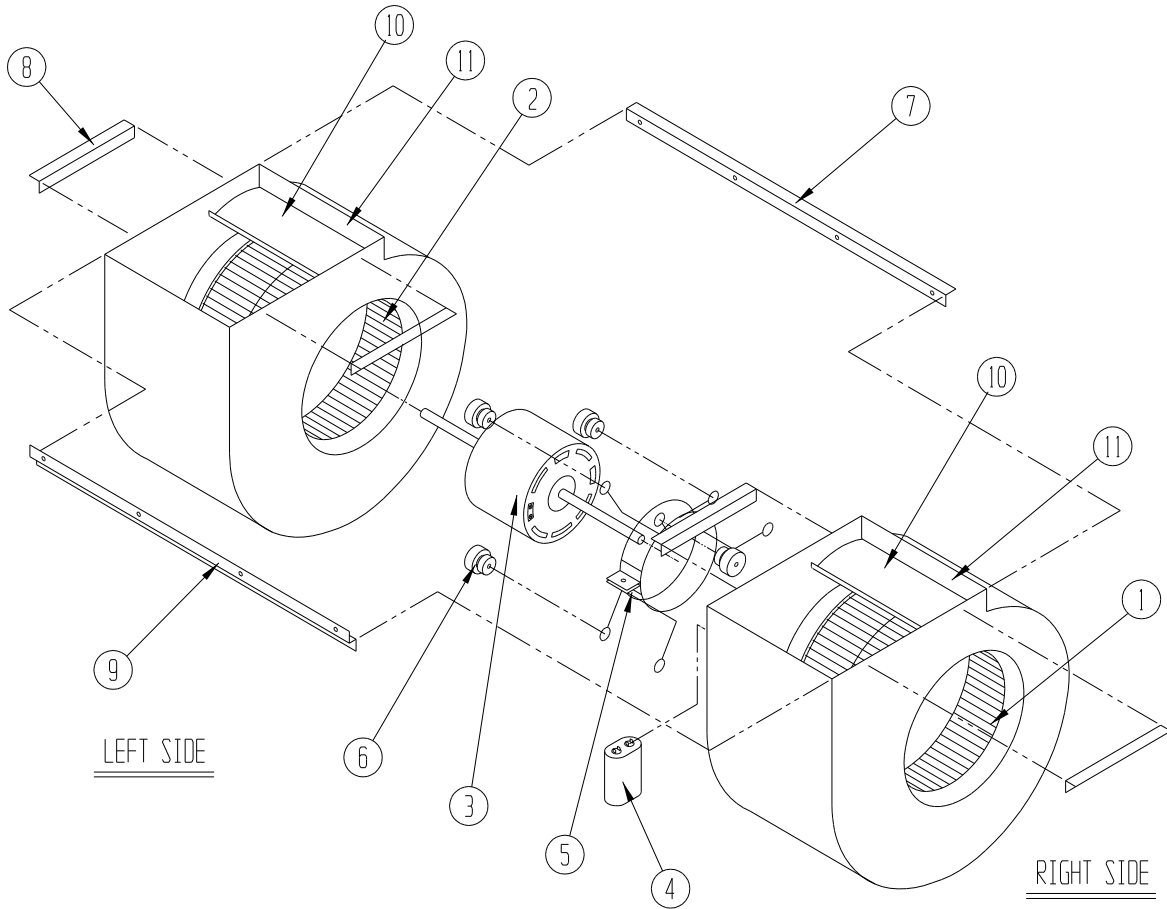

SEXP-178

Dwg No.	Part Number	Description	S900-183	S900-184	S900-185	S900-186
1	5152-011	10 Inch Wheel (CW)			X	X
1	5152-057	9 Inch Wheel (CW)	X	X		
2	5152-012	10 Inch Wheel (CW)			X	X
2	5152-058	9 Inch Wheel (CW)	X	X		
3	8106-046	Blower Motor (230/208)	X		X	
3	8106-025	Blower Motor (460)		X		X
4	8552-005	Capacitor	X	X	X	X
5	8200-040	Motor Mount	X	X	X	X
6	5451-011	Grommets	6	6	6	6
7	105-881	Back Brace	X	X	X	X
8	105-880	Side Angle	4	4	4	4
9	103-389	Front Brace	X	X	X	X
10	151-101	Housing	2	2	2	2
11	144-166	Diffuser	2	2	2	2