

---

# REPLACEMENT PARTS MANUAL

---

## WALL MOUNT ENERGY RECOVERY VENTILATOR

Models:

WERVPA2    WERVPC2    WERVPA3    WERVPC3

---

### General Notes

- Revised and/or additional pages may be issued from time to time.
- A complete and current manual consists of pages shown in the following contents section.

### Important

- Contact the installing and/or local Bard distributor for all parts requirements. Make sure to have the complete model and serial number available from the unit rating plates.

### Contents

Description	Page
Functional and Cabinet Components – WERVPA2, C2	
♦ Exploded View .....	2
♦ Usage List .....	3
Functional and Cabinet Components – WERVPA3, C3	
♦ Exploded View .....	4
♦ Usage List .....	5
Cassette Components	
♦ Exploded View .....	6
♦ Usage List .....	7
Rain Hood and Service Door	
♦ Exploded View .....	8
♦ Usage List .....	9
Control Panel	
♦ Layout View .....	10
♦ Usage List .....	10
Blower Assembly	
♦ Exploded View .....	11
♦ Usage List .....	11



Bard Manufacturing Company, Inc.  
Bryan, Ohio 43506  
www.bardhvac.com

Manual: 2110-700D  
Supersedes: 2110-700C  
Date: 2-23-18

# FUNCTIONAL AND CABINET COMPONENTS

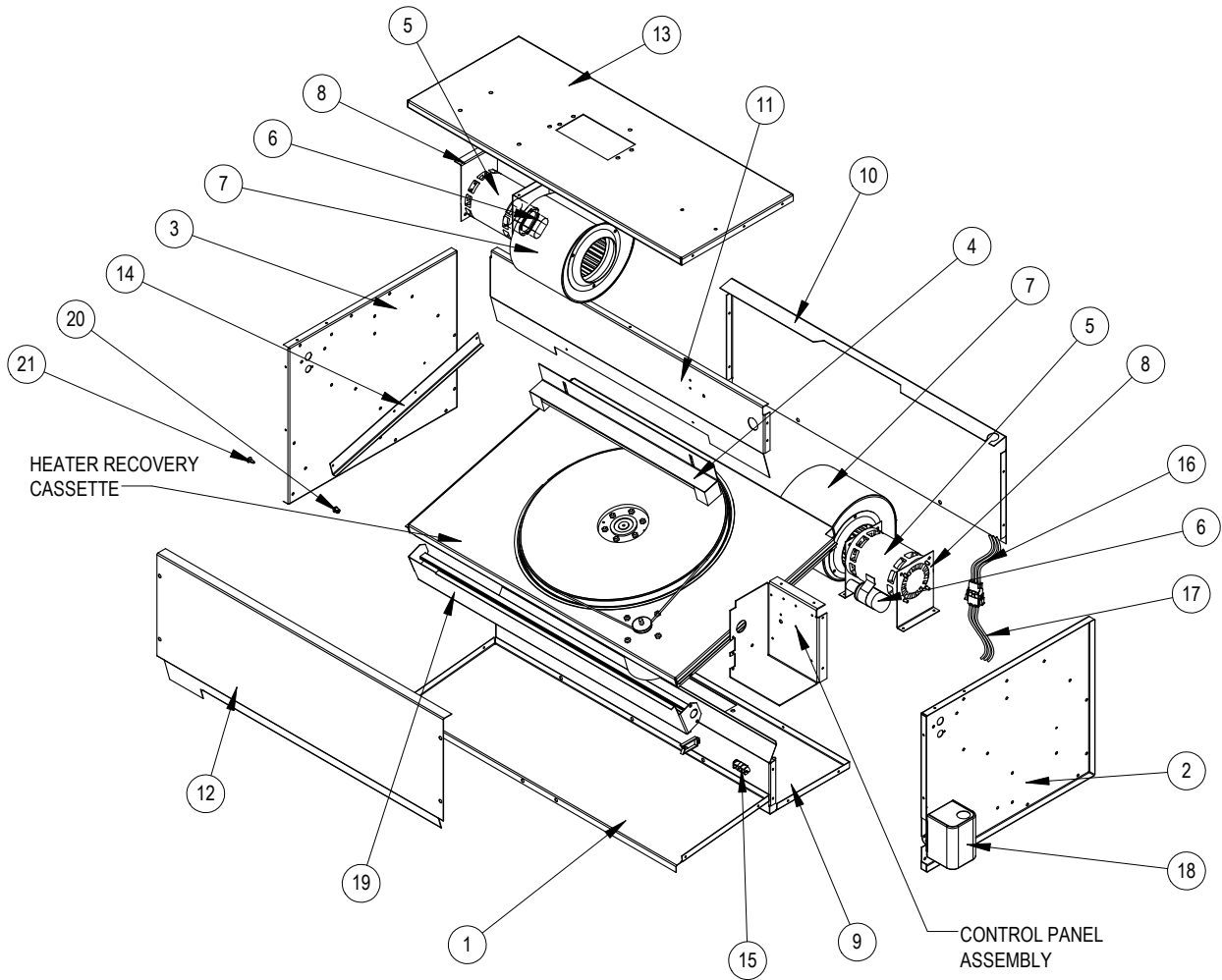

SEXP-789

## FUNCTIONAL AND CABINET COMPONENTS

---

Drawing No.	Part No.	Description	WERVPA2	WERVPC2
1	127-516	Base	X	X
2	500-942	Right End	X	X
3	500-941	Left End	X	X
4	S105-932	Adjustment Angle with Seal	X	X
5	910-2026	Blower Motor	2	
5	910-2027	Blower Motor		2
6	8552-001	Blower Motor Capacitor	2	2
7	Blower Housing and Wheel	See Blower Housing Assembly Drawing	2	2
8	129-018	Blower Motor Mount	4	4
9	520-275	Lower Partition Assembly	X	X
10	508-107	Back Assembly	X	X
11	520-274	Middle Partition Assembly	X	X
12	115-307	Front Assembly	X	X
13	506-155	Top Assembly	X	X
14	105-898	Slide Angle	2	2
15	300-1518	Wire Harness – 12-Pin Low Voltage Plug	X	X
16	3000-991	Wire Harness – 3-Pin High Voltage Receptacle	X	X
17	3000-992	Wire Harness – 3-Pin High Voltage Plug	X	X
18	8110-002	Damper Motor	X	X
19	139-342	Damper Blade	X	X
20	8611-057	3/16" Bushing	X	X
21	8611-059	Canoe Clip	X	X
NS	4056-232	Wiring Diagram	X	
NS	4056-315	Wiring Diagram		X

NS = Not Shown

# FUNCTIONAL AND CABINET COMPONENTS

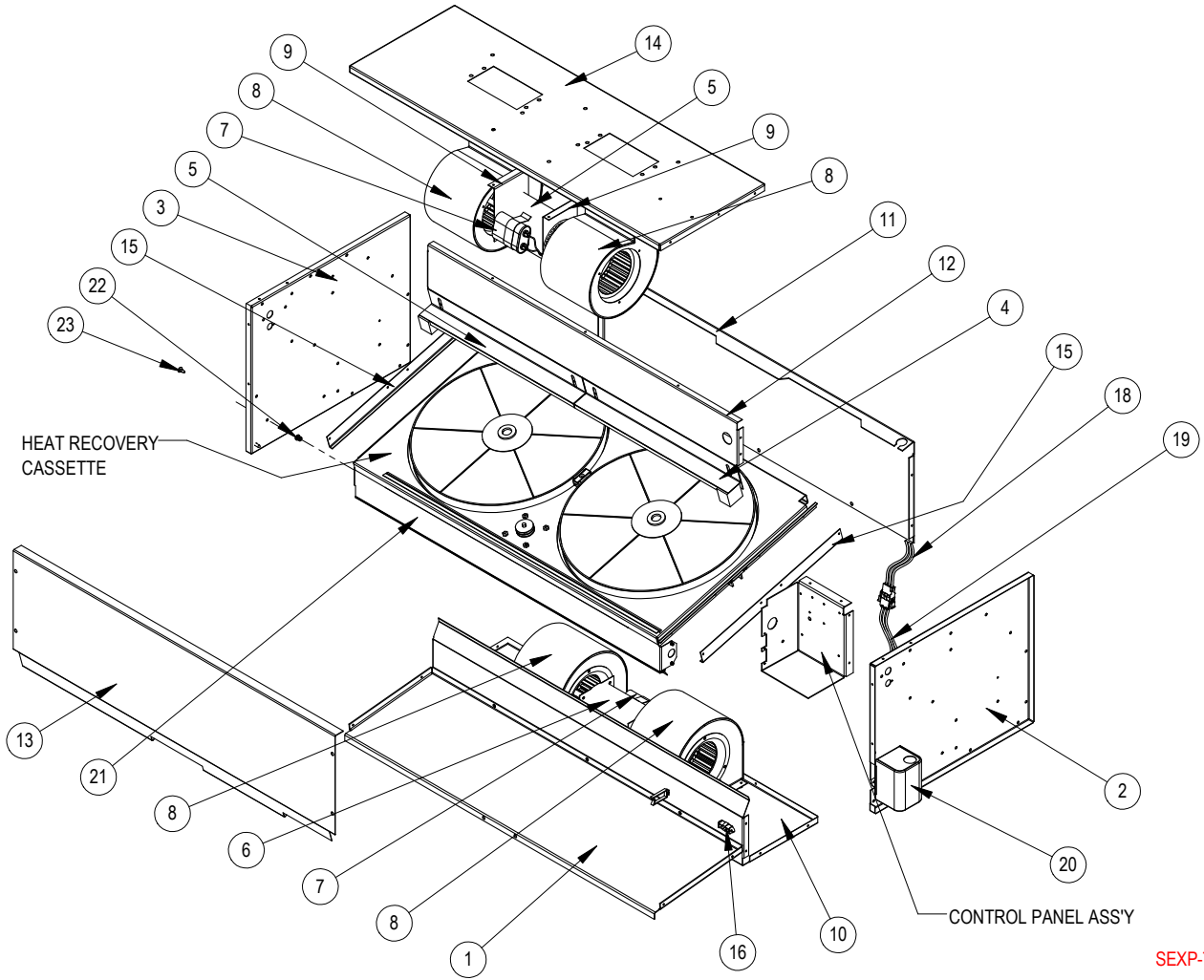

SEXP-790

## FUNCTIONAL AND CABINET COMPONENTS

---

Drawing No.	Part No.	Description	WERVPA3	WERVPC3
1	127-515	Base	X	X
2	500-942	Right End	X	X
3	500-941	Left End	X	X
4	S105-904	Right Adjustment Angle with Seal	X	X
5	S105-905	Left Adjustment Angle with Seal	X	X
6	8101-024	Blower Motor	2	
6	8101-025	Blower Motor		2
7	8552-001	Blower Motor Capacitor	2	2
8	Blower Housing and Wheel	See Blower Housing Assembly Drawing	4	4
9	129-018	Blower Motor Mount	4	4
10	121-316	Lower Partition Assembly	X	X
11	109-108	Back Assembly	X	X
12	121-242	Middle Partition Assembly	X	X
13	115-306	Front Assembly	X	X
14	107-147	Top Assembly	X	X
15	105-898	Slide Angle	2	2
16	300-1518	Wire Harness – 12-Pin Low Voltage Plug	X	X
18	3000-991	Wire Harness – 3-Pin High Voltage Receptacle	X	X
19	3000-1104	Wire Harness – 3-Pin High Voltage Plug	X	X
20	8110-002	Damper Motor	X	X
21	139-341	Damper Blade	X	X
22	8611-057	3/16" Bushing	X	X
23	8611-059	Canoe Clip	X	X
NS	4056-232	Wiring Diagram	X	
NS	4056-315	Wiring Diagram		X

NS = Not Shown

# CASSETTE COMPONENTS

---

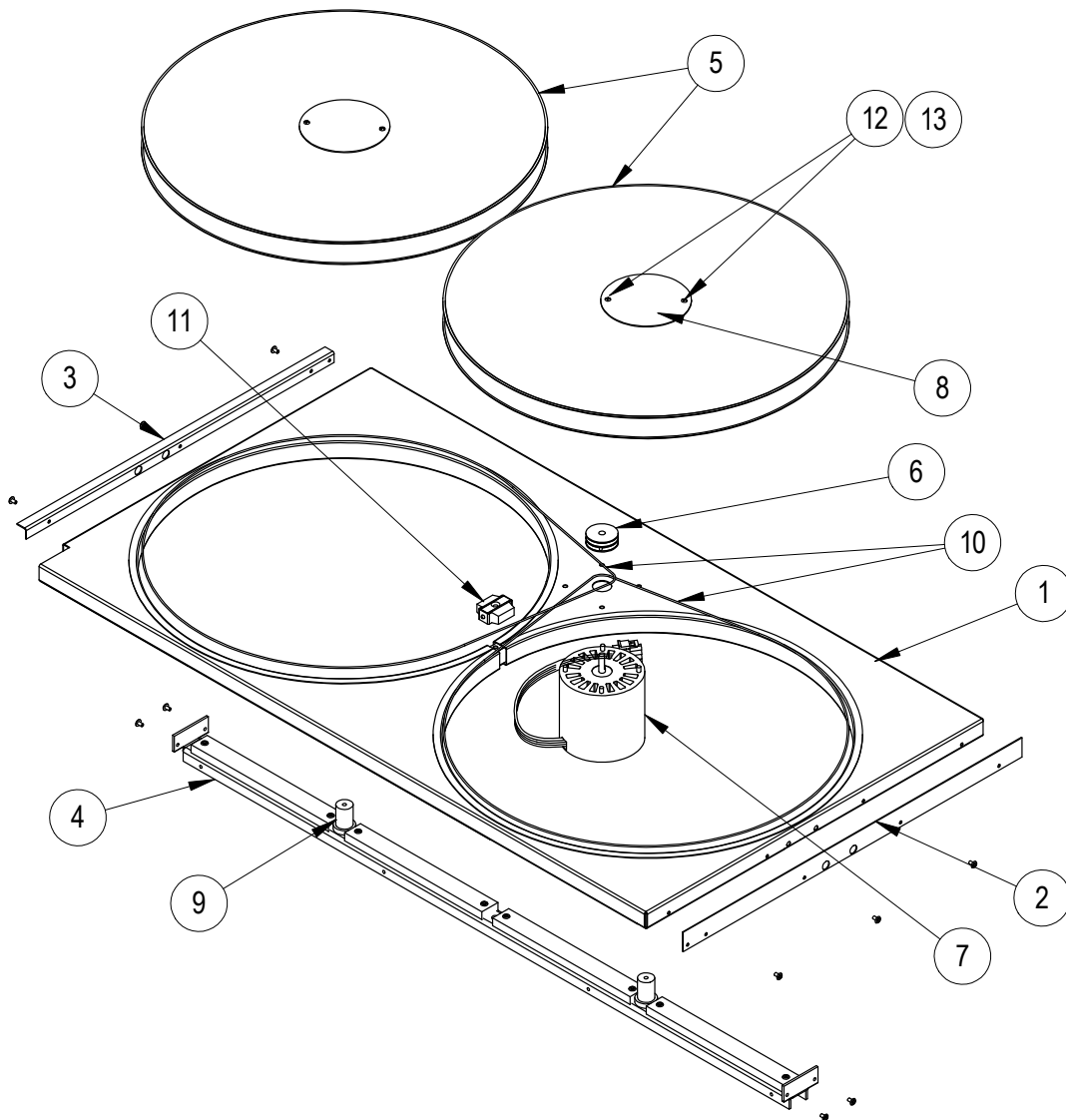

SEXP-472

# CASSETTE COMPONENTS

Drawing No.	Part No.	Description	WERVPA2 WERVPC2	WERVPA3 WERVPC3
	5070-033 5070-034	Complete Cassette with Motor and Wheels Complete Cassette with Motor and Wheels	X	X
1	139-172	Cassette Plate Assembly	X	
1	139-171	Cassette Plate Assembly		X
2	104-1131	Right Support Angle	X	X
3	104-1132	Left Support Angle	X	X
4	S140-312	Support Bar Assembly		X
4	S140-313	Support Bar Assembly	X	
5	5070-044	Cassette Wheel	X	2
6	5501-019	Pulley	X	
6	5501-020	Pulley		X
7	8101-016	Motor	X	X
8	142-104	Hub Cover	1	2
9	1912-012	Wheel Shaft	X	2
10	8620-195	Drive Belt and Pulley Kit		X
10	5070-005	Drive Belt	X	
11	S5070-047	Center Block Assembly		X
12	1012-164	Machine Screw	2	4
13	8611-111	Nylon Spacer	2	4
NS	5070-052	Bearing/Hub Assembly		2
NS	8620-204 ①	Bearing/Hub, Shaft and Hardware Kit	1	2
NS	8620-205 ②	Shaft and Hardware Kit	1	2

NS = Not Shown

① Contains Item #'s 8, 9, 12, 13 and "NS" Bearing + Additional Hardware

② Contains Item #'s 8, 9, 12, 13 + Additional Hardware

# RAIN HOOD AND SERVICE DOOR

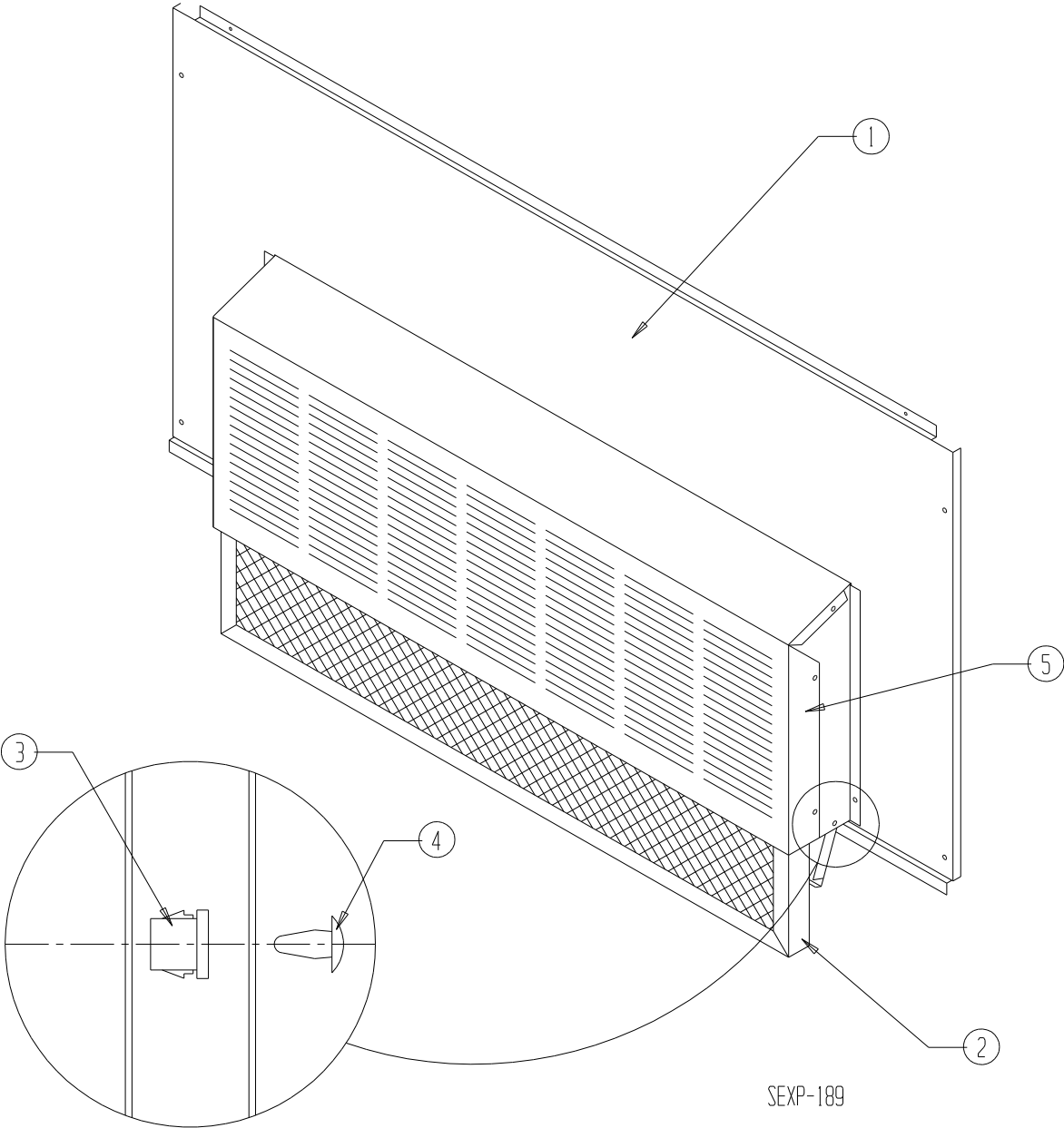



## RAIN HOOD AND SERVICE DOOR

---

Drawing No.	Part No.	Description	WERVPA2	WERVPA3
			WERVPC2	WERVPC3
1	S552-453-*	Vent Option Door	X	
1	S552-445-*	Vent Option Door		X
2	7003-034	Mist Eliminator	X	
2	7003-033	Mist Eliminator		X
3	8611-057	Bushing	2	2
4	8611-059	Canoe Clip	2	2
5	962033	Beige Rain Hood Complete with Mist Eliminator		X
5	962034	White Rain Hood Complete with Mist Eliminator		X
5	962035	Mesa Tan Rain Hood Complete with Mist Eliminator		X
5	962036	Desert Brown Rain Hood Complete with Mist Eliminator		X
5	962037	Buckeye Gray Rain Hood Complete with Mist Eliminator		X
5	962049	Beige Rain Hood Complete with Mist Eliminator	X	
5	962050	White Rain Hood Complete with Mist Eliminator	X	
5	962051	Mesa Tan Rain Hood Complete with Mist Eliminator	X	
5	962055	Desert Brown Rain Hood Complete with Mist Eliminator	X	
5	962053	Buckeye Gray Rain Hood Complete with Mist Eliminator	X	

\* Exterior cabinet parts are manufactured with various color options. To ensure the proper color is received, include the complete model and serial number of the unit for which parts are being ordered.

# CONTROL PANEL

Drawing No.	Part No.	Description	WERVPA2	WERVPC2	WERVPA3	WERVPC3
1	117-265	Control Panel	X	X	X	X
2	8552-100	Cassette Motor Capacitor	X	X	X	X
3	8201-086	Blower Relay	X	X	X	X
4	8407-043	Transformer	X	X	X	X
5	400-0087	Terminal Block	X	X	X	X
6	910-1637	Terminal Block			X	X

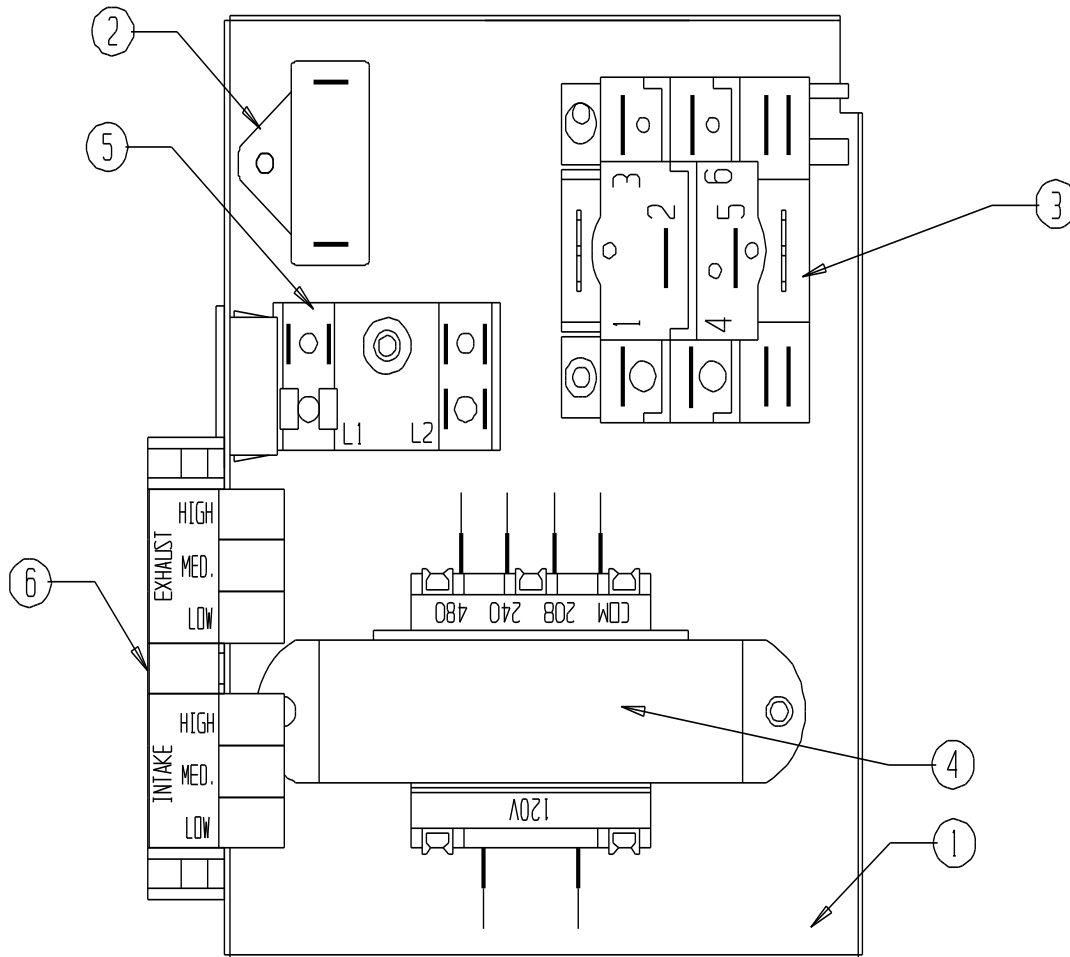

SEXP-454 A

# BLOWER ASSEMBLY

Drawing No.	Part No.	Description	All Models
1	5152-078	Blower Wheel	1
2	144-188	Inlet Ring	2
3	151-119	Blower Housing	1

