

REPLACEMENT PARTS MANUAL

WATER SOURCE HEAT PUMP MODELS WPV24, WPV30B, WPV36B

Manual 2110-726

Revision C

Date 7-31-92

Supersedes 11-05-91

* GENERAL NOTES *

*Revised and/or additional pages may be issued from time to time.
*A complete and current manual consists of pages dated as shown in the following index.

** INDEX **

<u>Page Description</u>	<u>Page</u>	<u>Date</u>	<u>Supersedes</u>
Cabinet Components--Exploded View	1	7-31-92	7-11-89
" " --Usage List	2	7-31-92	11-05-91
Functional Components--Exploded View	3	11-05-91	7-11-89
" " --Usage List	4	11-05-91	9-01-90
Control Panel--Layout View	5	7-11-89	
" " --Usage List	6	11-05-91	9-01-90

*** IMPORTANT ***

Contact the installing and/or local Bard distributor for all parts requirements. Make sure you have the complete model and serial number available from the unit rating plate.

BARD MANUFACTURING COMPANY

BRYAN, OHIO 43506

CABINET COMPONENTS

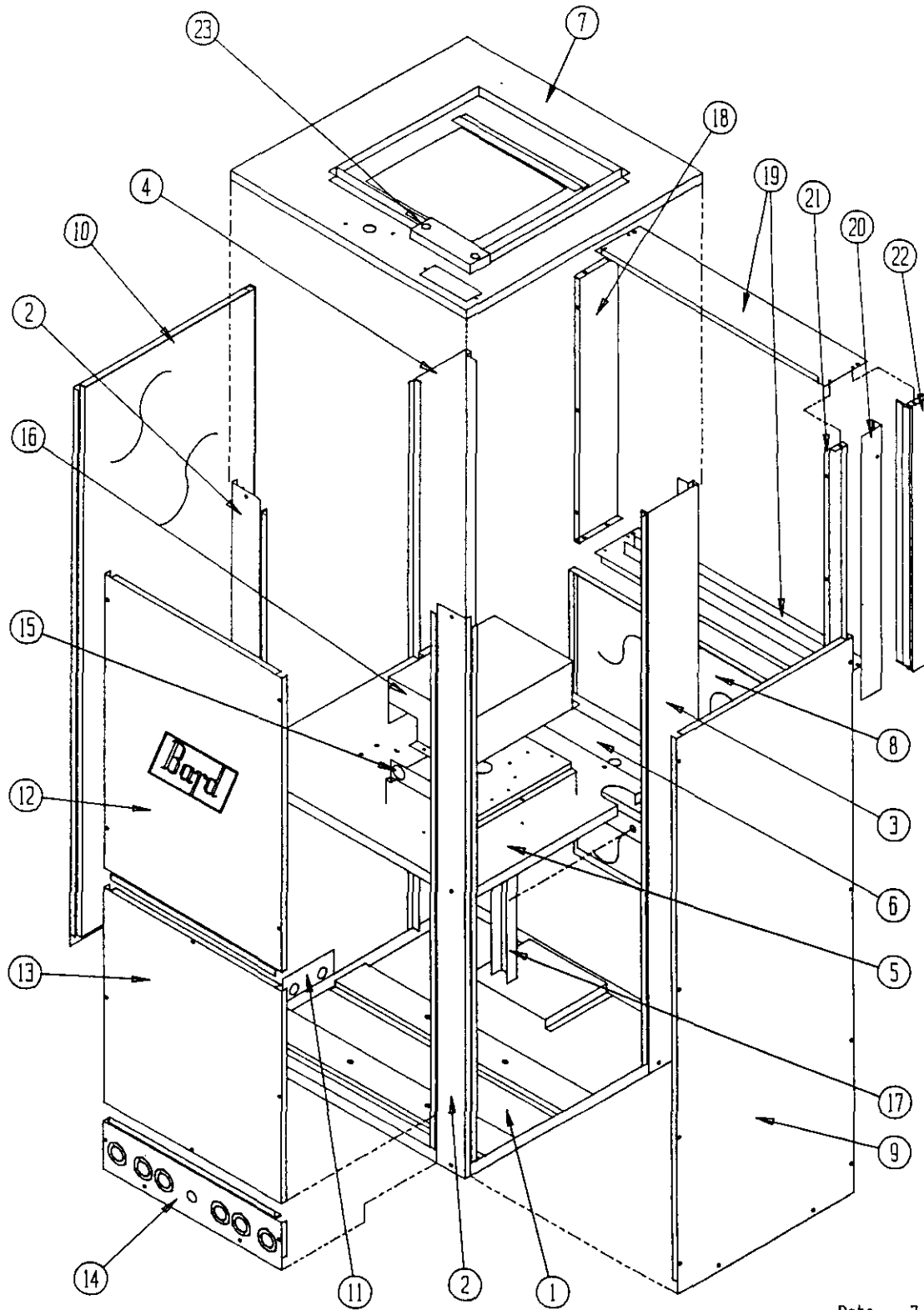

Date: 7-31-92
Supersedes: 7-11-89

CABINET COMPONENTS

Dwg. No.	Part No.	Description	WPV24	WPV30B	WPV36B
1	127-145	Base Weld Assembly	X	X	X
2	548-003	Front Corner Assembly	(2)	(2)	(2)
3	549X001	Right Rear Corner Assembly	X	X	X
4	549Y001	Left Rear Corner Assembly	X	X	X
5	520-118	Partition Assembly	X	X	X
6	523-004	Water Pan Assembly	X	X	X
7	507-110	Top Assembly	X	X	X
8	509-072	Lower Back Assembly	X	X	X
9	552-006	Right Access Assembly	X	X	X
10	552-157	Left Access Assembly	X	X	X
11	156-022	Tubing Entrance Assembly	X	X	X
12	514-004	Top Front Assembly	X	X	X
13	514-005	Bottom Front Assembly	X	X	X
14	556-020	Water Entrance Panel Assembly	X	X	X
15	116-114	Control Panel	X	X	X
16	132-006	Control Panel Cover	X	X	X
17	140-143	Support--Water Coil Hold Down	X	X	X
18	130-008	Filter Rack Side	X	X	X
19	131-006	Filter Rack Top and Bottom Weld Assembly	X	X	X
20	130-005	Filter Rack Door	X	X	X
21	130-009	Filter Rack Side	(2)	(2)	(2)
22	131-007	Filter Rack Side Weld Assembly	X	X	X
23	132-112	Terminal Board Cover	X	X	X

Date: 7-31-92
 Supersedes: 11-05-91

FUNCTIONAL COMPONENTS

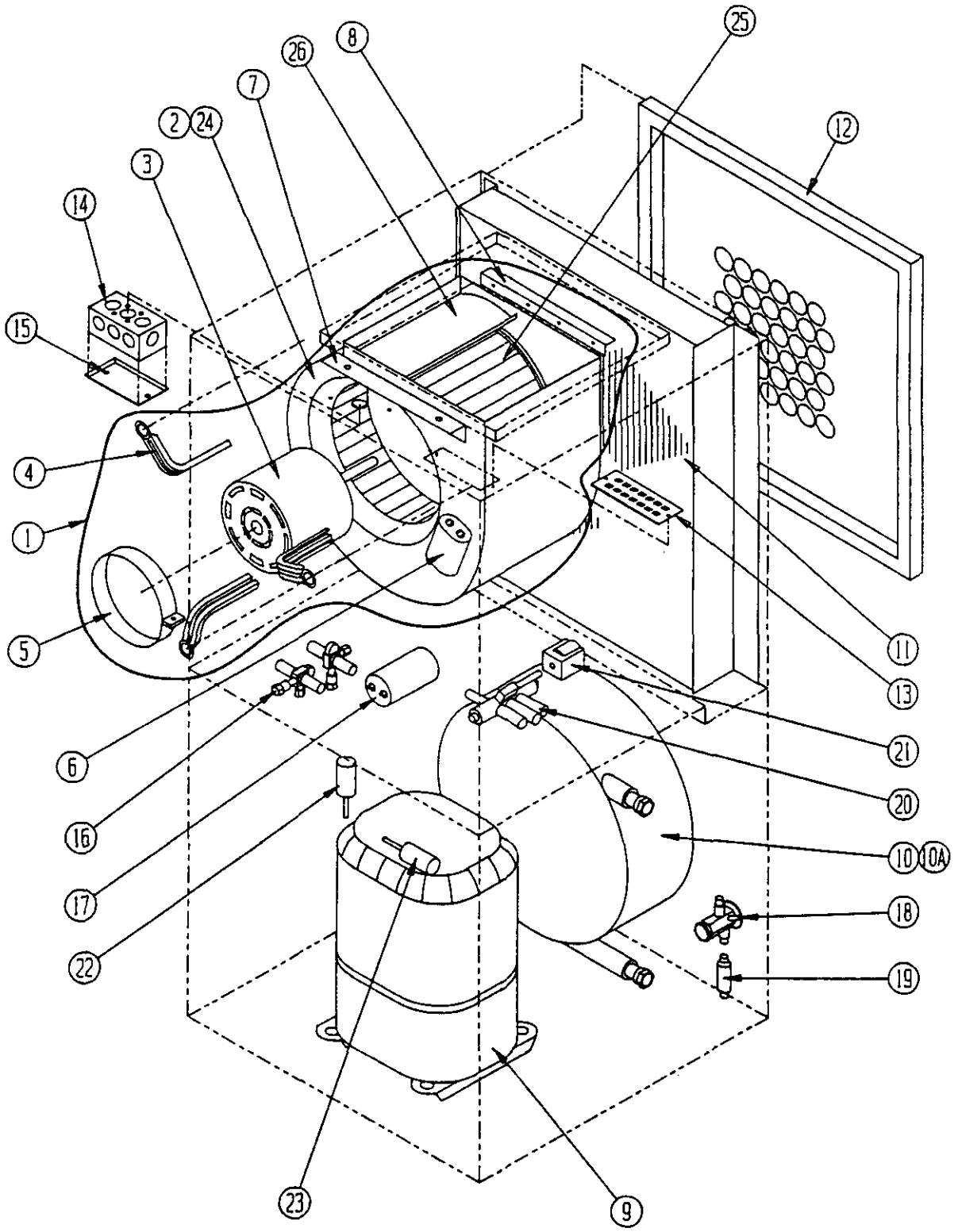

FUNCTIONAL COMPONENTS

	Part No.	Description	WPV24	WPV30B	WPV36B
1	900-048	Blower Assembly Complete (See Note)		A	A
1	900-162	Blower Assembly Complete (See Note)		B	B
1	900-172	Blower Assembly Complete	X		
2	5152-046	Blower Housing with Wheel and Diffuser		X	X
3	8104-008	Motor 1/4 HP	X		
3	8105-010	Motor 1/3 h.p. (See Note)		A	A
3	8105-022	Motor 1/3 h.p. (See Note)		B	B
4	8200-036	Motor Mount Arm with Grommets	3	3	3
5	8200-033	Motor Mount Band	X	X	X
6	8552-002	Capacitor 5 MFD--370 V--1-1/4" Oval (See Note)	X	A	A
6	8552-004	Capacitor 7-1/2 MFD--370V--1-1/4" Oval (See Note)		B	B
7	104-503	Angle--Front		X	X
7	104-865	Angle--Front	X		
8	104-504	Angle--Rear	X	X	X
9	8000-052	Compressor CRG3-0250-PFV-270			X
9	8000-101	Compressor 703283-02-1074		X	
9	8000-129	Compressor ZR18K1-PFV-230	X		
10	917-0018	Water Coil Assembly w/Insulation		X	
10	917-0017	Water Coil Assembly w/Insulation			X
10	917-0024	Water Coil Assembly W/Insulation	X		
10A	5020-026	Insulation Jacket Only	X	X	X
11	5060-0	Evaporator Coil	X	X	X
12	7004-0	Filter 22x22x1	X	X	X
13	8607-019	Terminal Board 24V	X	X	X
14	8614-002	Outlet Box 2" x 4"	X	X	X
15	8614-003	Blank Cover 2" x 4"	X	X	X
16	5651-055	Full Flow Valve 3/8"	2	2	
16	5651-056	Full Flow Valve 1/2"			2
17	8552-027	Capacitor 25/370V	X		
17	8552-035	Capacitor 40/370V 2" round			X
17	8552-045	Capacitor 30/370 1-3/4" R		X	
18	5651-066	Expansion Valve		X	X
18	5651-085	Expansion Valve	X		
19	5210-010	Strainer	(2)	(2)	(2)
20	5650-005	Reversing Valve	X	X	
20	5650-009	Reversing Valve			X
21	5650-008	Reversing Valve Solenoid	X	X	X
22	8406-045	Low Pressure Switch	X	X	X
23	8406-016	High Pressure Switch	X	X	X
24	151-100	Blower Housing	X		
25	5152-003	Blower Wheel	X		
26	144-165	Blower Diffuser	X		
OPTIONAL ITEMS					
	8603-016	Solenoid Valve 24V	X	X	X
	8603-010	Constant Flow Valve 4 GPM	X	X	
	8603-011	Constant Flow Valve 5 GPM			X
	8604-080	Duct Heater 5KW	X	X	X
	8604-081	Duct Heater 9.8KW	X	X	X
	8604-082	Duct Heater 14.7KW	X	X	X
	8604-083	Duct Heater 19.2KW	X	X	X

NOTE A: For units produced before date code L90.

NOTE B: For units produced with date code L90 and after.

Date: 11-05-91
Supersedes: 9-01-90

2110-726

Page: 4

CONTROL PANEL

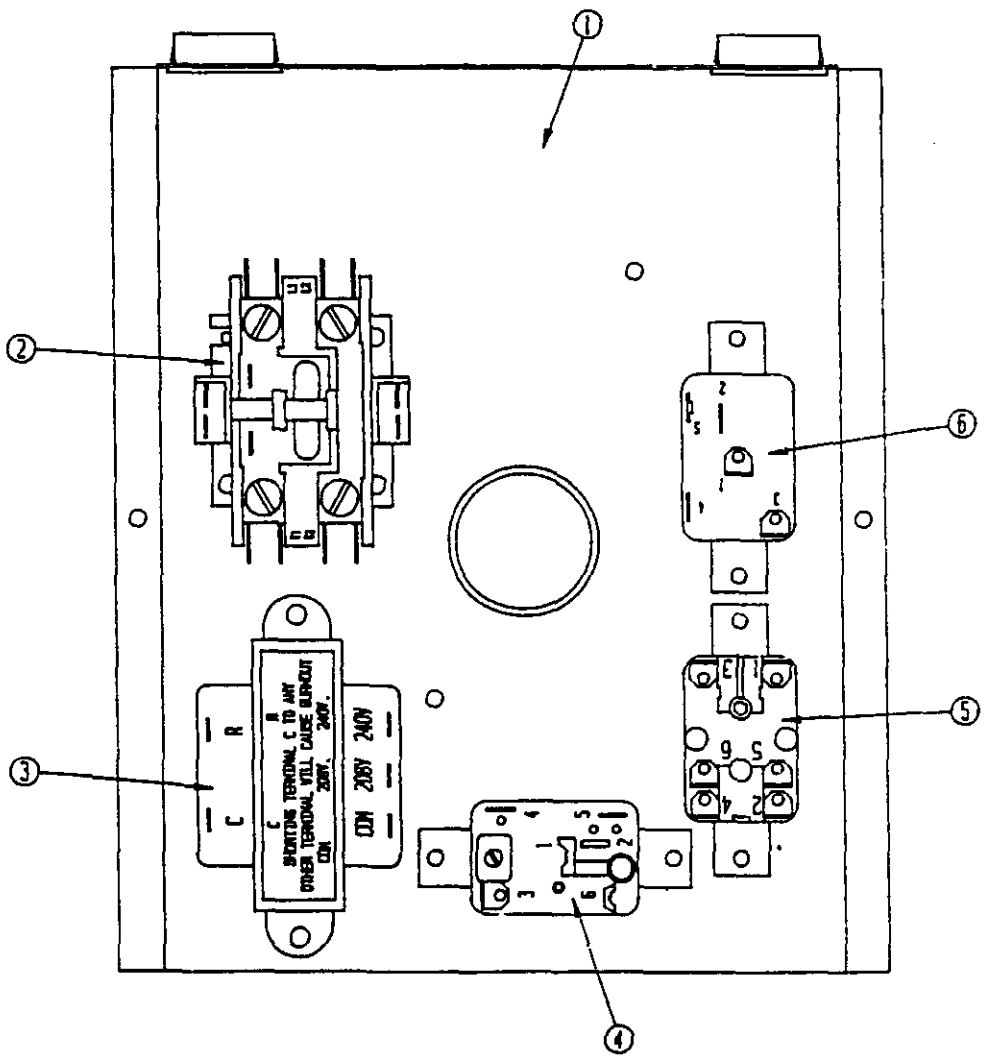

Date: 7-11-89
Supersedes:

CONTROL PANEL

Item	Part No.	Description	WPV24	WPV30B	WPV36B
1	116-114	Control Panel	X	X	X
2	8401-007	Compressor Contactor		X	X
2	8401-026	Compressor Contactor 1P25A With 5 Min. Time Delay	X		
3	8407-035	Transformer	X	X	X
4	8201-034	Lockout Relay	X	X	X
5	8201-015	Emergency Heat Relay	X	X	X
6	8201-008	Blower Relay	X	X	X
	4054-110	Wiring Diagram (See Note)		A	A
	4054-112	Wiring Diagram (See Note)		B	B
	4054-113	Wiring Diagram	X		

NOTE A: For units produced before date code L90.

NOTE B: For units produced with date code L90 and after.

Date: 11-05-91
Supersedes: 9-01-90

2110-726
Page: 6