REPLACEMENT PARTS MANUAL

GROUND SOURCE and GROUND WATER SOURCE HEAT PUMP

MODELS: **GSVS242-A**
GSVS302-A
GSVS361-A
GSVS421-A

General Notes

- Revised and/or additional pages may be issued from time to time.
- A complete and current manual consists of pages shown in the following contents section.

Important

- Contact the installing and/or local Bard distributor for all parts requirements. Make sure you have the complete model and serial number available from the unit rating plates.

Contents

Description	Page
Cabinet Components	
♦ Exploded View	1
♦ Usage List	2
Functional Components	
♦ Exploded View	3
♦ Usage List	4
Control Panel	
♦ Exploded View	5
♦ Usage List	6



CLIMATE CONTROL SOLUTIONS

BARD MANUFACTURING COMPANY
Bryan, Ohio 43506
Since 1914...Moving ahead, just as planned.

Manual: 2110-734D
Supersedes: 2110-734C
File: Tab 8
Date: 02-23-05

CABINET COMPONENTS

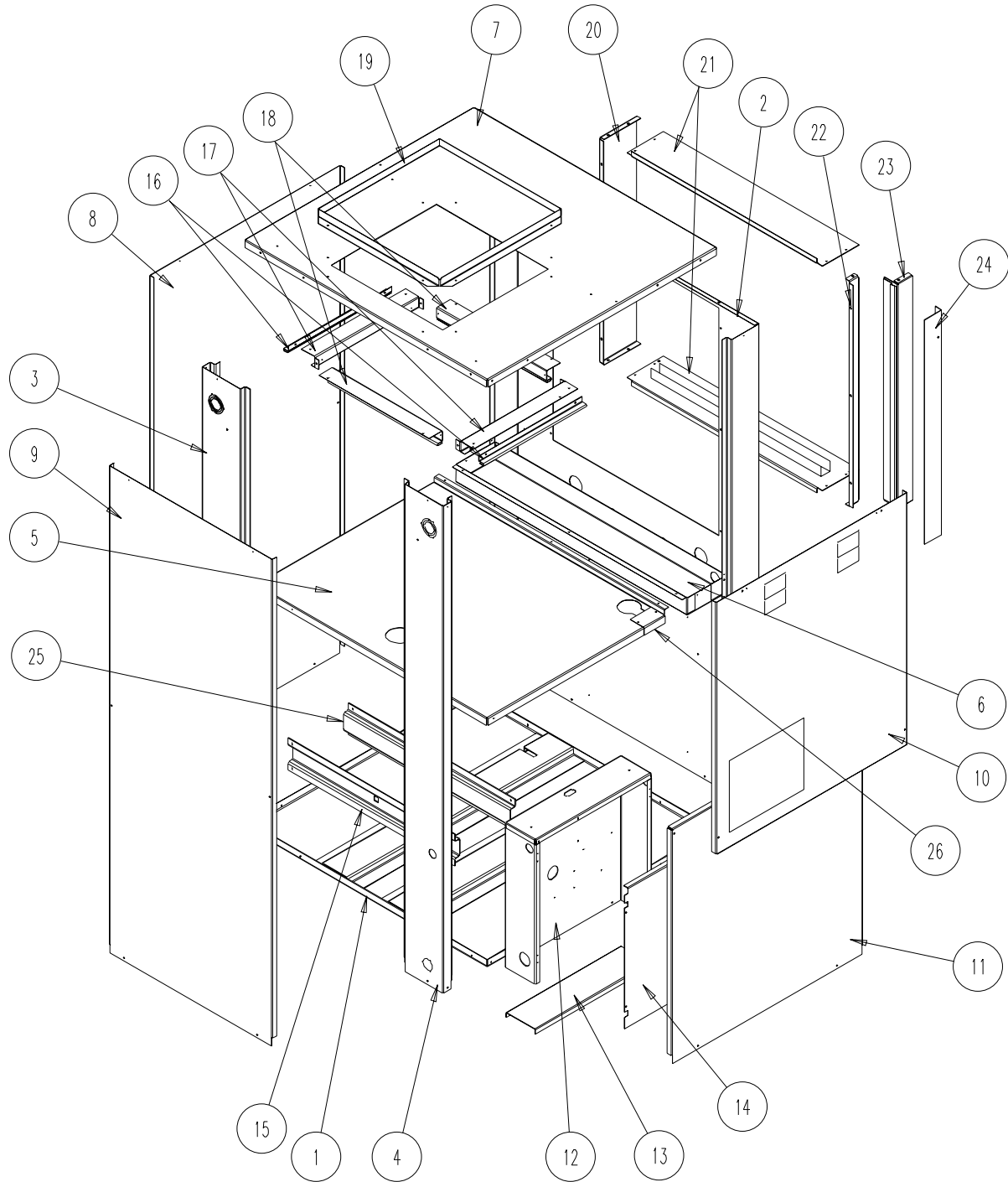

SEXP-292

CABINET COMPONENTS

Drawing No.	Part No.	Description	GSVS242-A	GSVS302-A	GSVS361-A	GSVS421-A
1	127-296	Base Assembly	X	X	X	X
2	509-151	Back Assembly	X	X	X	X
3	549-093	Right Corner	X	X	X	X
4	549-094	Left Corner	X	X	X	X
5	520-329	Partition	X	X	X	X
6	523-101	Drain Pan Assembly	X	X	X	X
7	507-217	Top	X	X	X	X
8	553-321	Door	X	X	X	X
9	501-358	Side Assembly	X	X	X	X
10	553-320	Upper Door	X	X	X	X
11	553-319	Lower Door	X	X	X	X
12		Control Panel (See Control Panel Drawing)	X	X	X	X
13	116-221	Control Panel Base	X	X	X	X
14	132-157	Control Panel Cover	X	X	X	X
15	140-261	Water Coil Support	X	X	X	X
16	140-262	Blower Hanger	2	2	2	2
17	140-263	Blower Slide End	2	2	2	2
18	144-177	Blower Slide	2	2	2	2
19	105-1035	Plenum Angle	X	X	X	X
20	131-132	Filter Rack Side – Right	X	X	X	X
21	131-130	Filter Rack Top and Base	2	2	2	2
22	131-131	Filter Rack Side – Left	X	X	X	X
23	131-133	Filter Rack Side – Left	X	X	X	X
24	131-129	Filter Rack Door	X	X	X	X
25	140-265	Water Coil Support	X	X	X	X
26	136-425	Cover Plate	X	X	X	X

FUNCTIONAL COMPONENTS

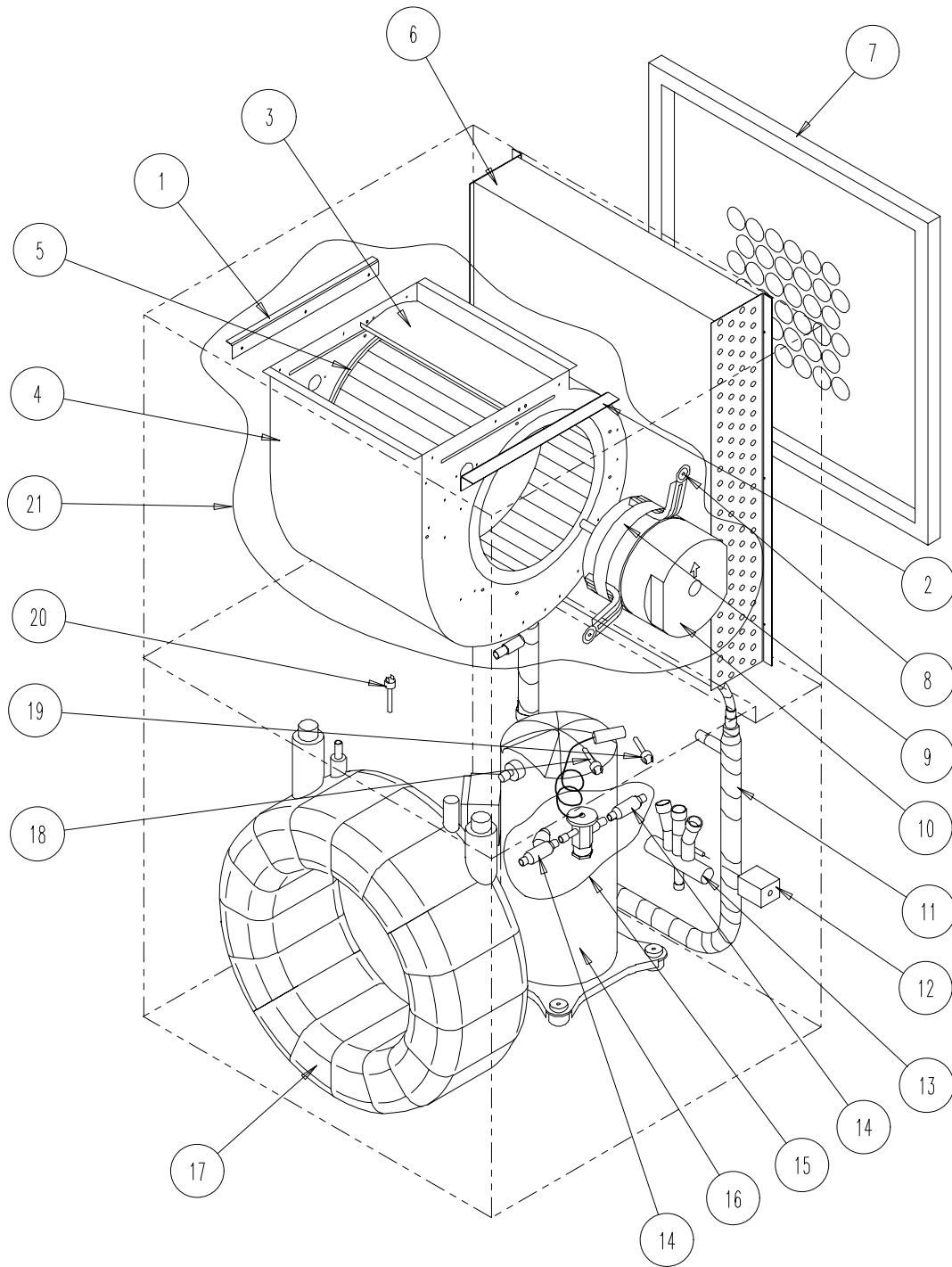

SEXP-293

FUNCTIONAL COMPONENTS

Drawing No.	Part No.	Description	GSVS242-A	GSVS302-A	GSVS361-A	GSVS421-A
1	104-1034	Blower Angle	X	X	X	X
2	104-1033	Blower Angle	X	X	X	X
3	144-128	Blower Diffuser	X	X	X	X
4	151-113	Blower Housing	X	X	X	X
5	5152-014	Blower Wheel	X	X	X	X
6	5060-097	Evaporator Coil	X	X		
6	5060-098	Evaporator Coil			X	
6	5060-099	Evaporator Coil				X
7	7004-017	Filter 22 x 22 x 1	X	X	X	X
8	8200-034	Motor Mount Arm	3	3	3	3
9	8200-033	Motor Mount Band	X	X	X	X
10	8106-035-0006	Motor 1/2 HP ECM	X			
10	8106-035-0009	Motor 1/2 HP ECM		X		
10	8106-035-0010	Motor 1/2 HP ECM			X	
10	8106-035-0011	Motor 1/2 HP ECM				X
11	5052-012	Desuperheater Coil	X	X	X	X
12	5650-027	Reversing Valve Solenoid	X	X	X	X
13	5650-033	Reversing Valve	X			
13	5650-032	Reversing Valve		X		
13	5650-031	Reversing Valve			X	
13	5650-030	Reversing Valve				X
14	5210-010	Strainer	2	2	2	2
15	800-0262	Expansion Valve 5651-150	X			
15	800-0274	Expansion Valve 5651-151		X		
15	800-0275	Expansion Valve 5651-152			X	
15	800-0276	Expansion Valve 5651-153				X
16	8000-257	Compressor ZR18K4-PFV	X			
16	8000-258	Compressor ZR22K4-PFV		X		
16	8000-172	Compressor ZR28K3-PFV			X	
16	8000-175	Compressor ZR34K3-PFV				X
17	917-0045	Water Coil Assembly 5052-009	X			
17	917-0046	Water Coil Assembly 5052-010		X		
17	917-0047	Water Coil Assembly 5052-011			X	X
18	1804-0242	Low Pressure Switch 27 PSIG 8406-095	X	X	X	X
19	1804-0243	Low Pressure Switch 15 PSIG 8406-096	X	X	X	X
20	1804-0241	High Pressure Switch 8406-094	X	X	X	X
21	900-238-001	Blower Assembly	X			
21	900-238-002	Blower Assembly		X		
21	900-238-003	Blower Assembly			X	
21	900-238-004	Blower Assembly				X
NS	3000-1212	Low Voltage Motor Leads	X	X	X	X
NS	3000-1089	High Voltage Motor Leads	X	X	X	X

CONTROL PANEL

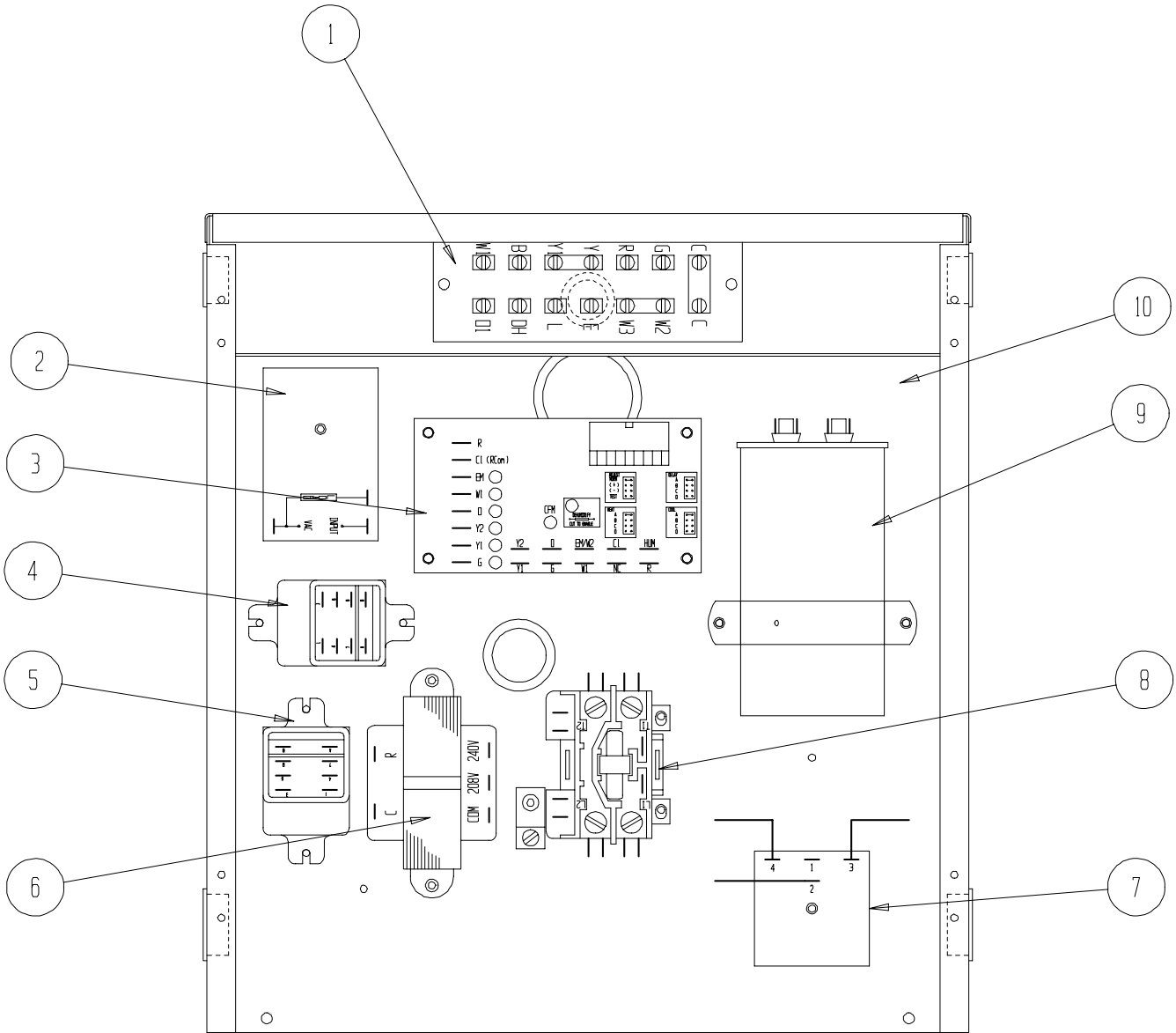

SEXP-294

CONTROL PANEL

Drawing No.	Part No.	Description	GSVS242-A	GSVS302-A	GSVS361-A	GSVS421-A
1	8607-019	Terminal Board	X	X	X	X
2	8201-084	Blinker Relay	X	X	X	X
3	8201-083	Blower Control	X	X	X	X
4	8201-048	Relay – Low Pressure Lockout	X	X	X	X
5	8201-048	Relay – Emergency Heat	X	X	X	X
6	8407-035	Transformer	X	X	X	X
7	8201-079	Solid State Lockout Control	X	X	X	X
8	8401-007	Contactora	X	X	X	X
9	8552-032	Capacitor 35 mf / 370V	X	X		
9	8552-043	Capacitor 45 mf / 370V			X	
9	8552-063	Capacitor 50+5 mf / 370V				X
10	116-220	Control Panel	X	X	X	X