WATER SOURCE HEAT PUMPS

MODELS:

REPLACEMENT PARTS MANUAL

GTB1-A	Blower Section
GTA3600UD1AA	Coil Section
GTA4860UD1AA	Coil Section
GTC36S2-ADCX	Compressor Section
GTC48S2-ADCX	Compressor Section
GTC60S2-ADCX	Compressor Section
GTC36S2-ADNX	Compressor Section
GTC48S2-ADNX	Compressor Section
GTC60S2-ADNX	Compressor Section

General Notes

- Revised and/or additional pages may be issued from time to time.
- A complete and current manual consists of pages shown in the following contents section.

Important

- Contact the installing and/or local distributor for all parts requirements. Make sure you have the complete model and serial number available from the unit rating plates.

Contents

Description	Page
Blower Section	
♦ Exploded View	2
♦ Usage List	3
♦ Exploded View	4
♦ Usage List	5
"A" Coil Section	
♦ Exploded View	6
♦ Usage List	7
Compressor Section	
♦ Exploded View	8
♦ Usage List	9
♦ Exploded View	10
♦ Usage List	11

BMC, Inc.
Bryan, Ohio 43506

**Manufactured under the following
U.S. patent number:
8,127,566**

Manual: 2110-737K
Supersedes: 2110-737J
File: Volume I, Tab 8
Date: 04-29-14

BLOWER SECTION

SEXP-576

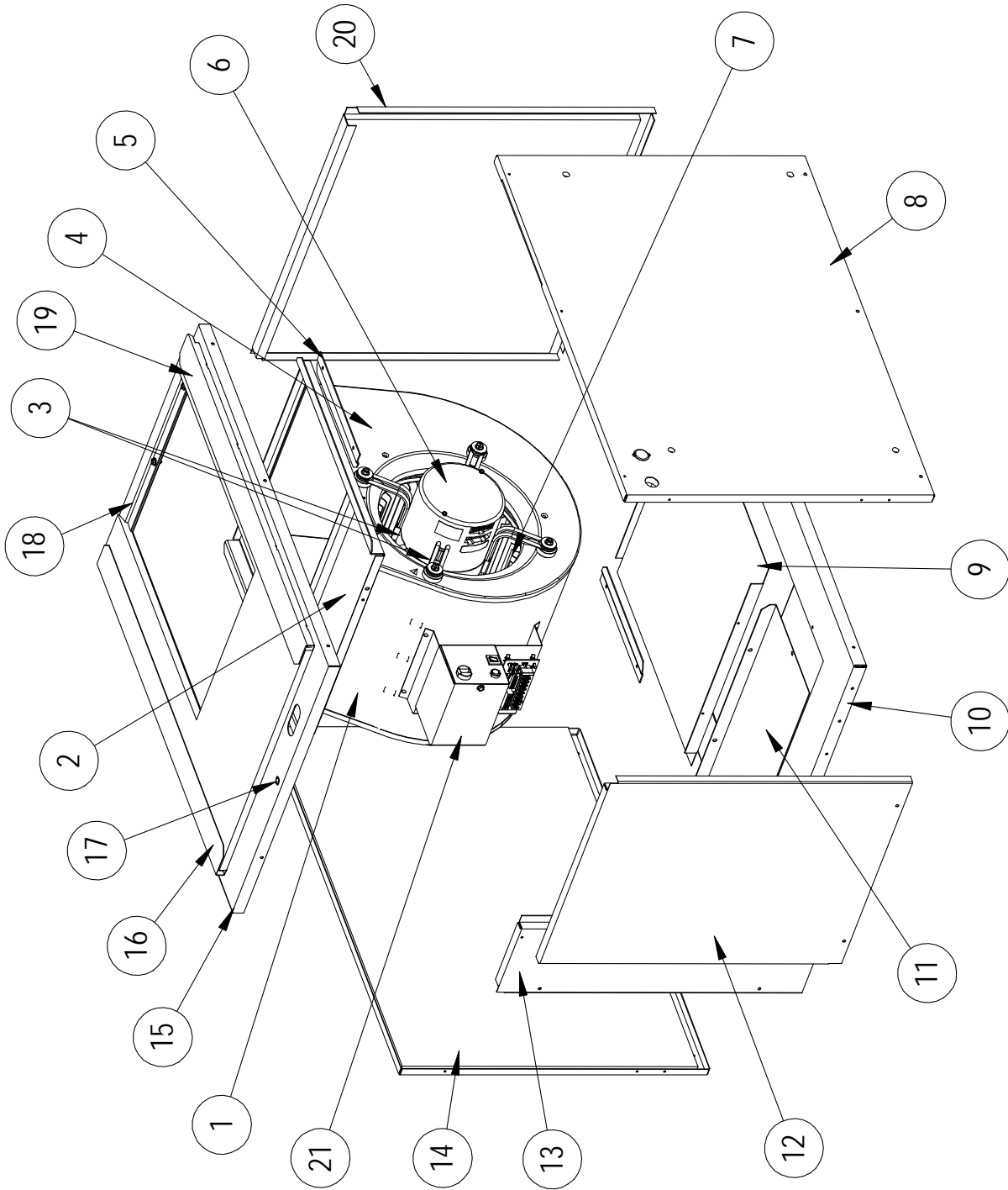

BLOWER SECTION

Drawing No.	Part No.	Description	GTB1-A
1	900-306	Complete Blower Assembly	X
2	141-351	Blower Mounting Plate	X
3	8620-216	Motor Mount Band and Arms Kit	X
4	151-122	Blower Housing	X
5	103-477	Blower Offset	4
6	S8107-009-0074	3/4 HP Programmed Motor with Control	X
6	C8107-009-0074	Motor Control Module Only	X
7	5152-049	Blower Wheel	X
8	501-595-1	Right Side	X
9	136-601	Rear Blower Base Fill Plate	X
10	S127-389	Base	X
11	136-600	Front Blower Base Fill Plate	X
12	S553-480-1	Front Door	X
13	515-184-1	Front Corner	X
14	501-594-1	Left Side	X
15	S107-285-1	Top	X
16	141Y349	Left Blower Top Rail	X
17	1012-222	1/4-20 Hex Threaded Insert	X
18	103-478	Rear Securing Offset	X
19	141X349	Right Blower Top Rail	X
20	509-244-1	Back	X
21		See Control Panel Drawing	X

BLOWER SECTION

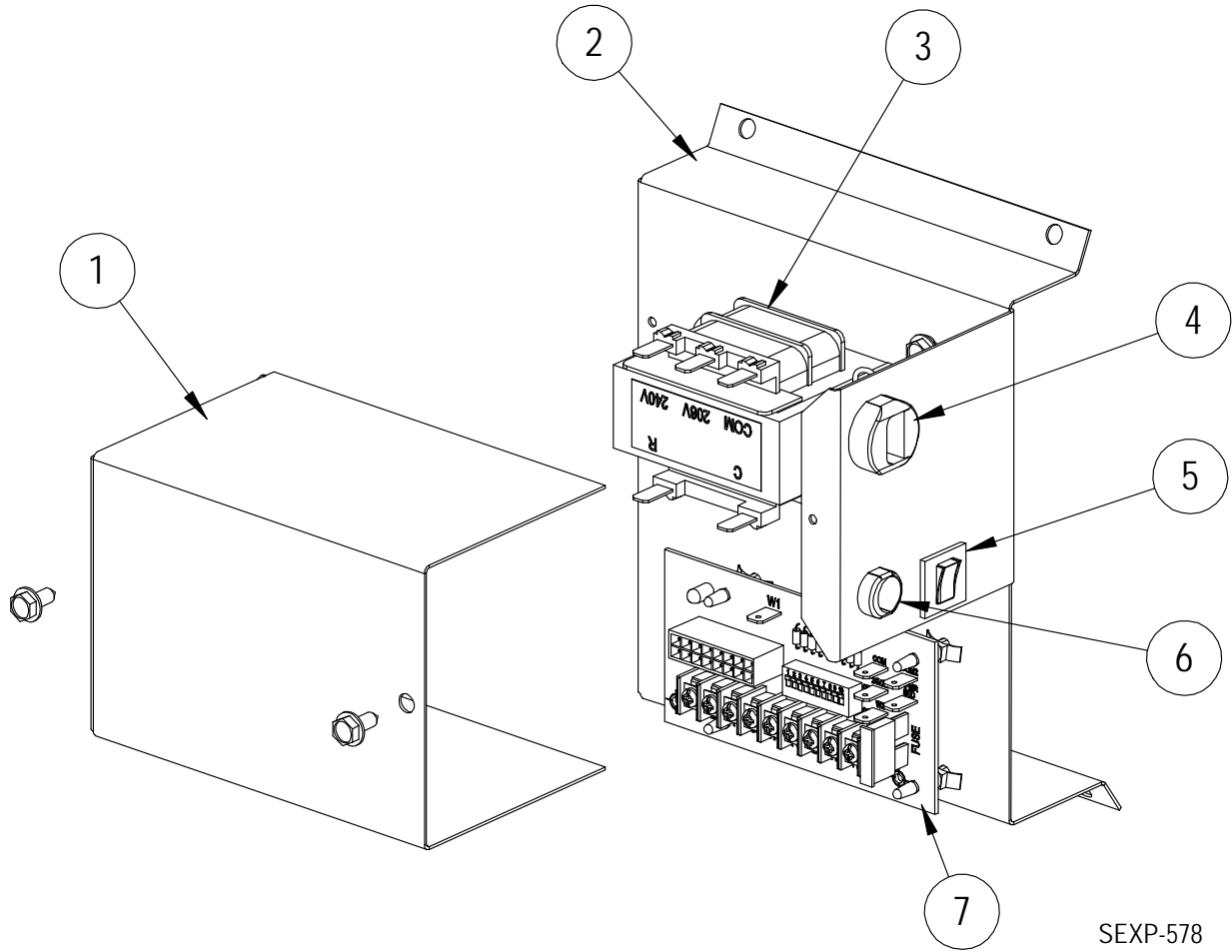

SEXP-578

BLOWER SECTION

Drawing No.	Part No.	Description	GTB1-A
1	S143-143	Lower Control Panel Cover	X
2	117-297	Lower Control Panel	X
3	8407-035	50VA Transformer	X
4	8611-019	Strain Relief	X
5	8614-036	3 Amp Circuit Breaker	X
6	8611-020	Strain Relief	X
7	8201-121	Electronic Control Module	X
NS	3000-1350	Power Harness	X
NS	3000-1351	ECM Control Harness	X

"A" COIL SECTION

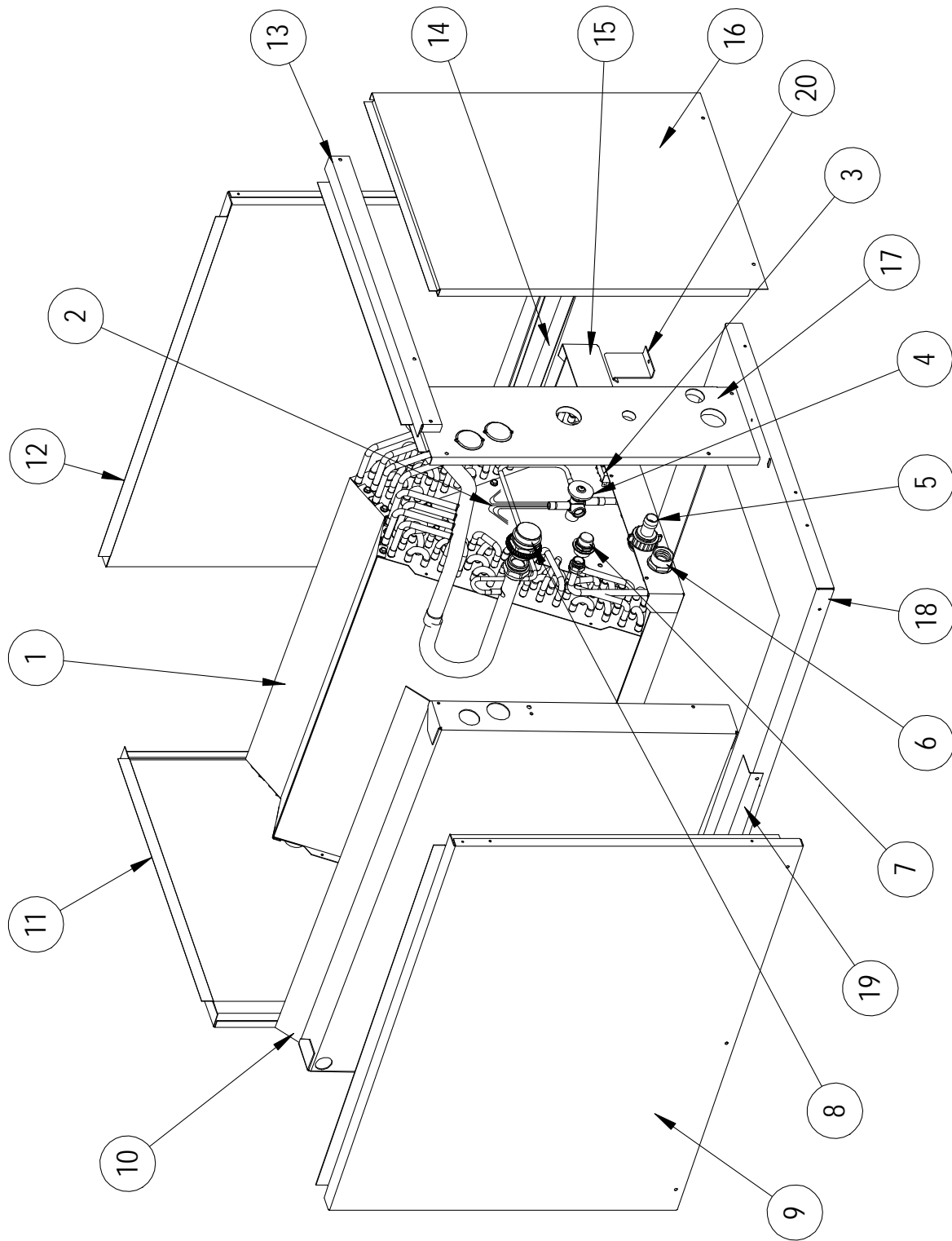

SEXP-575

"A" COIL SECTION

GTA3600UD1AA

GTA4860UD1AA

Drawing No.	Part No.	Description		
1	S917-0178	Coated Coil Assembly	X	
1	S917-0179	Coated Coil Assembly		X
2	800-0406	Cooling Distributor	X	X
3	8607-017	Terminal Block	X	X
4	5651-210	Expansion Valve	X	
4	5651-212	Expansion Valve		X
5	6094-011	3/4" Barbed Drain Pan Fitting	X	X
6	6094-003	Secondary Drain Pan Fitting	X	X
7	7000-042	3/8" Male Coupling	X	X
8	7000-044	3/4" Male Coupling	X	X
9	501-592-1	Left Side	X	X
10	123-135	Horizontal Drain Pan (Optional)	X	X
11	509-243-1	Back	X	X
12	S501-593-1	Right Side	X	X
13	515-183-1	Evaporator Front Fill	X	X
14	105X1223	Right Drain Pan Angle	X	X
15	S123-134	Drain Pan	X	X
16	553-476-1	Front Door	X	X
17	515-182-1	Evaporator Access Plate	X	X
18	527-388	Base	X	X
19	105Y1223	Left Drain Pan Angle	X	X
20	141-352	Drain Pan Support Clip	X	X

COMPRESSOR SECTION

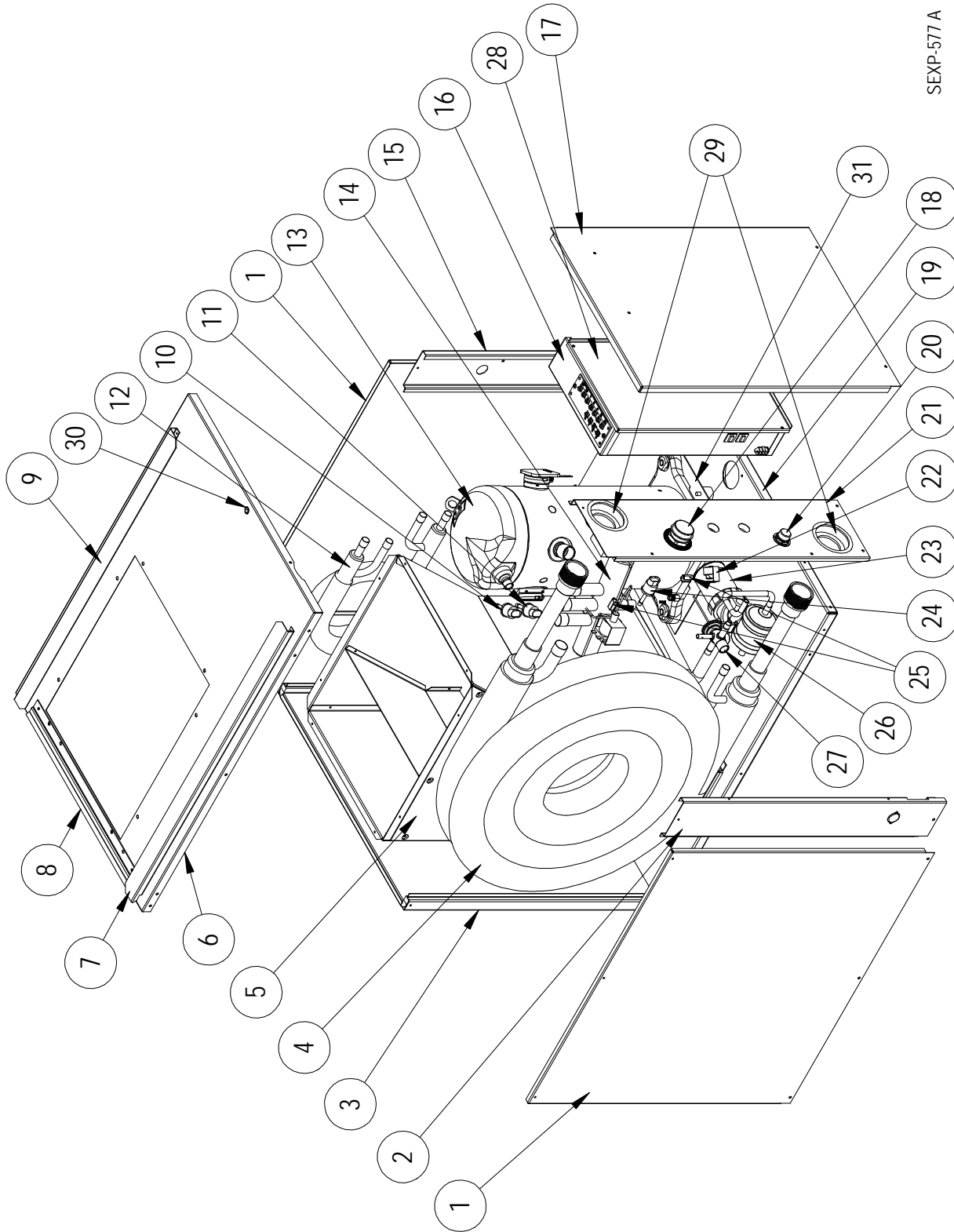

SEXP-577A

COMPRESSOR SECTION

Drawing No.	Part No.	Description	GTC36S2-ADCX	GTC48S2-ADCX	GTC60S2-ADCX	GTC36S2-ADNX	GTC48S2-ADNX	GTC60S2-ADNX
1	501-591-1	Side	2	2	2	2	2	2
2	549-113-1	Left Corner	X	X	X	X	X	X
3	509-242-1	Back	X	X	X	X	X	X
4	S917-0167	3-Ton Water Coil Assembly	X					
4	S917-0168	4-Ton Water Coil Assembly		X				
4	S917-0169	5-Ton Water Coil Assembly			X			
4	S917-0239	3-Ton Cupronickel Coil Assembly				X		
4	S917-0240	4-Ton Cupronickel Coil Assembly					X	
4	S917-0241	5-Ton Cupronickel Coil Assembly						X
5	S539-237	Condenser Duct Assembly	X	X	X	X	X	X
6	S107-284-1	Top	X	X	X	X	X	X
7	141Y354	Left Condenser Top Rail	X	X	X	X	X	X
8	103-480	Condenser Hold Down Offset	X	X	X	X	X	X
9	141X354	Right Condenser Top Rail	X	X	X	X	X	X
10	1804-0499	Low Pressure Switch (55 PSIG Open) Yellow	X	X	X	X	X	X
11	1804-0496	Low Pressure Switch (75 PSIG Open) Blue	X	X	X	X	X	X
12	917-0171	Desuperheater Coil Assembly	X	X	X	X	X	X
13	8000-379	Compressor	X			X		
13	8000-382	Compressor		X			X	
13	8000-385	Compressor			X			X
NS	8001-013	Compressor Grommet	4	4	4	4	4	4
NS	1012-328	5/16-18x1.94 Compressor Bolt	4	4	4	4	4	4
14	5650-039	Reversing Valve with 24V Solenoid Coil	X			X		
14	5650-040	Reversing Valve with 24V Solenoid Coil		X	X		X	X
15	S549-112-1	Right Corner	X	X	X	X	X	X
16		See Control Panel Drawing	X	X	X	X	X	X
17	S553-475-1	Condenser Service Door	X	X	X	X	X	X
18	7000-042	3/4" Male Coupling	X	X	X	X	X	X
19	527-387	Base	X	X	X	X	X	X
20	7000-044	3/8" Male Coupling	X	X	X	X	X	X
21	S515-180-1	Front Panel	X	X	X	X	X	X
22	8402-182	Water Temperature Limit	X	X	X	X	X	X
23	910-1765	Circulating Pump Assembly	X	X	X	X	X	X
24	1804-0316	High Pressure Switch	X	X	X	X	X	X
25	8408-040	Inlet Thermistor (Black Wires)	X	X	X	X	X	X
25	8408-043	Outlet Thermistor (Red Wires)	X	X	X	X	X	X
26	5201-020	Filter Drier	X	X	X	X	X	X
27	5651-210	Expansion Valve	X			X		
27	5651-211	Expansion Valve		X			X	
27	5651-212	Expansion Valve			X			X
28	S143-142	Control Panel Cover	X	X	X	X	X	X
29	6094-013	Closeout	2	2	2	2	2	2
30	1012-222	1/4-20 Hex Threaded Insert	X	X	X	X	X	X
31	140-369	Compressor Support Plate	X	X	X	X	X	X
NS	5451-018	Grommet	4	4	4	4	4	4
NS	1012-221	1/4-20 Hex Flange Nut	8	8	8	8	8	8

COMPRESSOR SECTION

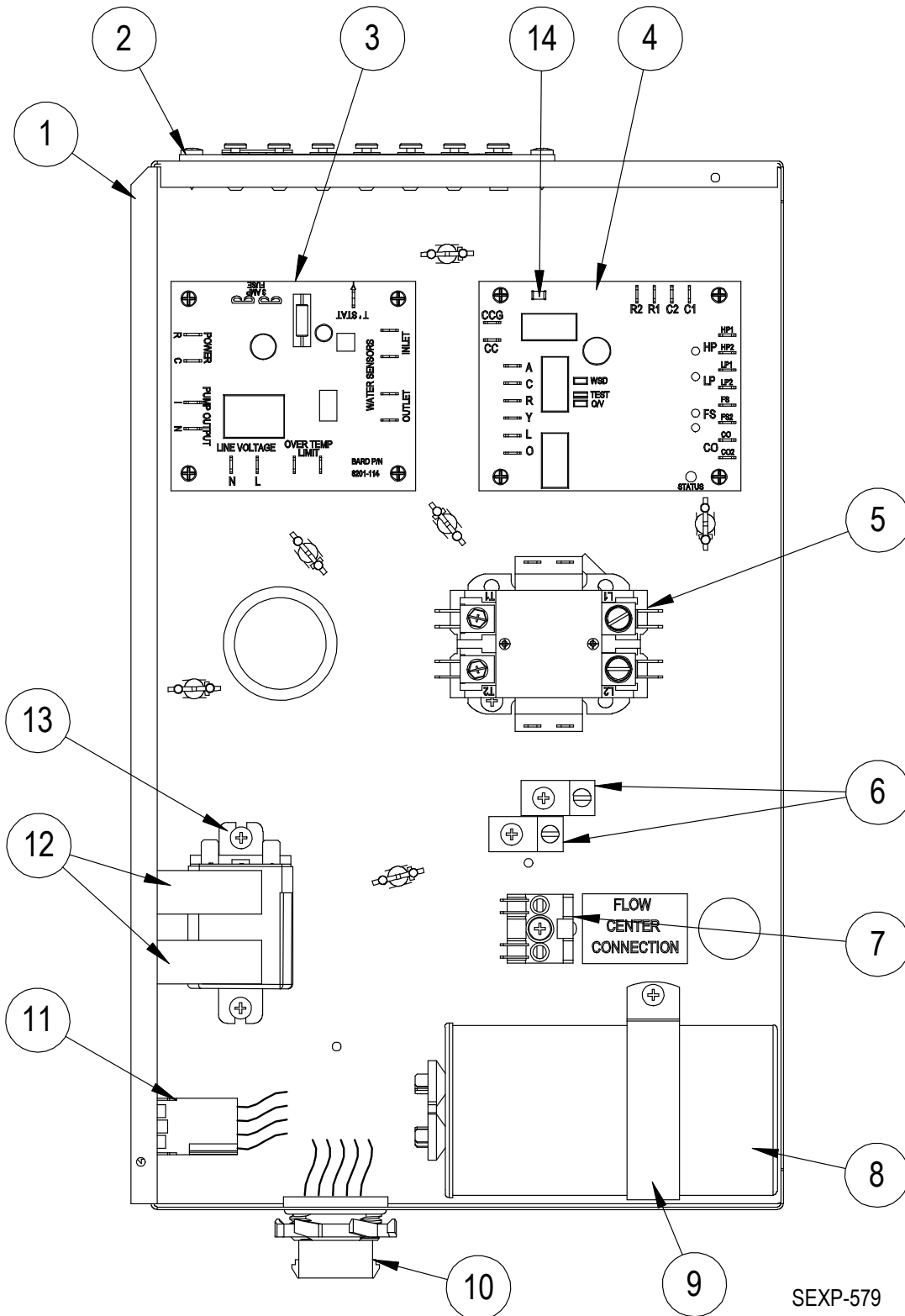

SEXP-579

COMPRESSOR SECTION

Drawing No.	Part No.	Description	GTC36S2-ADCX	GTC48S2-ADCX	GTC60S2-ADCX
1	117-296	Control Panel	X	X	X
2	8607-029	Terminal Strip	X	X	X
3	8201-114	Desuperheater Control Board	X	X	X
4	8201-140	Geothermal Logic Control	X	X	X
5	8401-033	2-Pole Contactor 20 Amp	X		
5	8401-034	2-Pole Contactor 40 Amp		X	X
6	8611-006	Terminal	2	2	2
7	8607-030	Screw to Tab Terminal Block	X	X	X
8	8552-035	Capacitor 40MFD 370V	X		
8	8552-095	Capacitor 30MFD 370V		X	
8	8552-096	Capacitor 40MFD 440V			X
9	8550-010	Capacitor Bracket		X	
9	8550-035	Capacitor Bracket	X		X
10	3000-1352	Wire Assembly	X	X	X
11	3000-1353	Wire Assembly	X	X	X
12	8614-036	Mini Circuit Breaker 3 Amp	2	2	2
13	8201-048	Relay	X	X	X
14	8614-052	3.15 Amp Glass Mini Fuse	X	X	X