Water-to-Water Geothermal Heat Pump

REPLACEMENT PARTS MANUAL

MODELS: **GW024**
GW036
GW048
GW060
GW070

General Notes

- Revised and/or additional pages may be issued from time to time.
- A complete and current manual consists of pages shown in the following contents section.

Important

- Contact the installing and/or local distributor for all parts requirements. Make sure you have the complete model and serial number available from the unit rating plates.

Contents

<i>Description</i>	<i>Page</i>
Cabinet Components	
♦ Exploded View	2
♦ Usage List	3
Functional Components	
♦ Exploded View	4
♦ Usage List	5
Control Panel	
♦ Exploded View	6
♦ Usage List	7

BMC, Inc.
Bryan, Ohio 43506

Manual: 2110-738A
Supersedes: 2110-738
File: Tab 8
Date: 06-04-13

CABINET COMPONENTS



SEXP-666

CABINET COMPONENTS

Drawing No.	Part No.	Description	GW0241S1-A1R *CX	GW0361S1-A1R *CX	GW0481S1-A1R *CX	GW0601S1-A1R *CX	GW0701S1-A1R *CX
1	S107-313-4	Top	X	X	X	X	X
2	553-546-4	Rear Door	X	X	X	X	X
3	501-717-4	Side	2	2	2	2	2
4	141-401	Coil Support	2	2	2	2	2
5	141-400	Coil Bracket	2	2	2	2	2
6	141-387	Base Rail	X	X	X	X	X
7	8550-010	1-3/4 strap	X	X	X	X	X
8	8550-011	2-1/2 strap	X	X	X	X	X
9	140-369	Compressor Support Plate	X	X	X	X	X
10	127-438	Base	X	X	X	X	X
11	115-228-4	Left Front Door	X	X			
11	115-226-4	Left Front Door			X		
11	115-224-4	Left Front Door				X	
11	115-222-4	Left Front Door					X
12	S553-54 	Front Door	X	X	X	X	X
13	115-229-4	Right Front Door	X	X			
13	115-227-4	Right Front Door			X		
13	115-225-4	Right Front Door				X	
13	115-223-4	Right Front Door					X
14	133-234	Control Panel Door	X	X	X	X	X
15		Control Panel (See Control Panel Drawing)	X	X	X	X	X

* C = Copper Source Coil
 N = Cupronickel Source Coil

FUNCTIONAL COMPONENTS

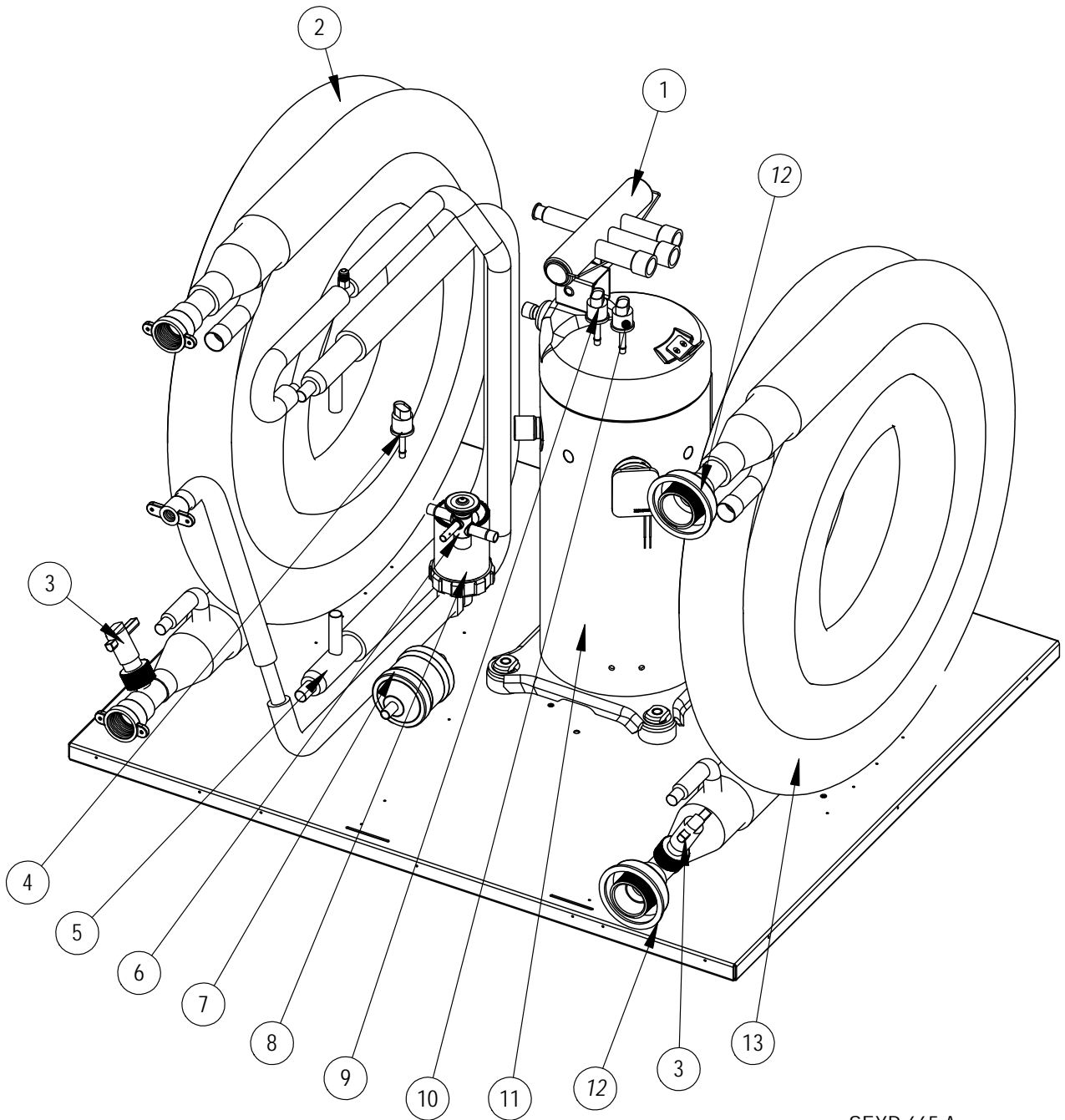

SEXP-665 A

FUNCTIONAL COMPONENTS

Drawing No.	Part No.	Description	GW0241S1-A1RCCX	GW0361S1-A1RCCX	GW0481S1-A1RCCX	GW0601S1-A1RCCX	GW0701S1-A1RCCX	GW0241S1-A1RNCX	GW0361S1-A1RNCX	GW0481S1-A1RNCX	GW0601S1-A1RNCX	GW0701S1-A1RNCX
1	5650-038	Reversing Valve ½ x ¾	X					X				
1	5650-039	Reversing Valve ½ x ¾		X					X			
1	5650-040	Reversing Valve ½ x ⅞			X	X				X	X	
1	5650-041	Reversing Valve ½ x ⅞					X					X
2	S917-0234	3-Ton Copper Load Coil Assembly	X	X				X	X			
2	S917-0235	4-Ton Copper Load Coil Assembly			X					X		
2	S917-0236	5-Ton Copper Load Coil Assembly				X					X	
2	S917-0237	6-Ton Copper Load Coil Assembly					X					X
3	910-1867	Flow Switch Assembly	2	2	2	2	2	2	2	2	2	2
4	1804-0327	High Pressure Switch	X	X	X	X	X	X	X	X	X	X
5	S917-0238	Desuperheater Coil Assy	X	X	X	X	X	X	X	X	X	X
6	5651-206	Expansion Valve	X					X				
6	5651-202	Expansion Valve		X					X			
6	5651-203	Expansion Valve			X					X		
6	5651-204	Expansion Valve				X					X	
6	5651-220	Expansion Valve					X					X
7	5201-018	Filter Drier	X	X				X	X			
7	5201-020	Filter Drier			X	X	X			X	X	X
8	910-1866	Pump Assembly	X	X	X	X	X	X	X	X	X	X
9	1804-0499	Low Pressure Switch	X	X	X	X	X	X	X	X	X	X
10	1804-0496	Low Pressure Switch	X	X	X	X	X	X	X	X	X	X
11	8000-394	Compressor	X					X				
11	8000-379	Compressor		X					X			
11	8000-382	Compressor			X					X		
11	8000-385	Compressor				X					X	
11	8000-395	Compressor					X					X
12	6094-013	Closeout	2	2	2	2	2	2	2	2	2	2
13	S917-0230	3-Ton Copper Source Coil Assembly	X	X								
13	S917-0231	4-Ton Copper Source Coil Assembly			X							
13	S917-0232	5-Ton Copper Source Coil Assembly				X						
13	S917-0233	6-Ton Copper Source Coil Assembly					X					
13	S917-0242	3-Ton Cupronickel Source Coil Assembly						X	X			
13	S917-0243	4-Ton Cupronickel Source Coil Assembly								X		
13	S917-0244	5-Ton Cupronickel Source Coil Assembly									X	
13	S917-0245	6-Ton Cupronickel Source Coil Assembly										X

CONTROL PANEL

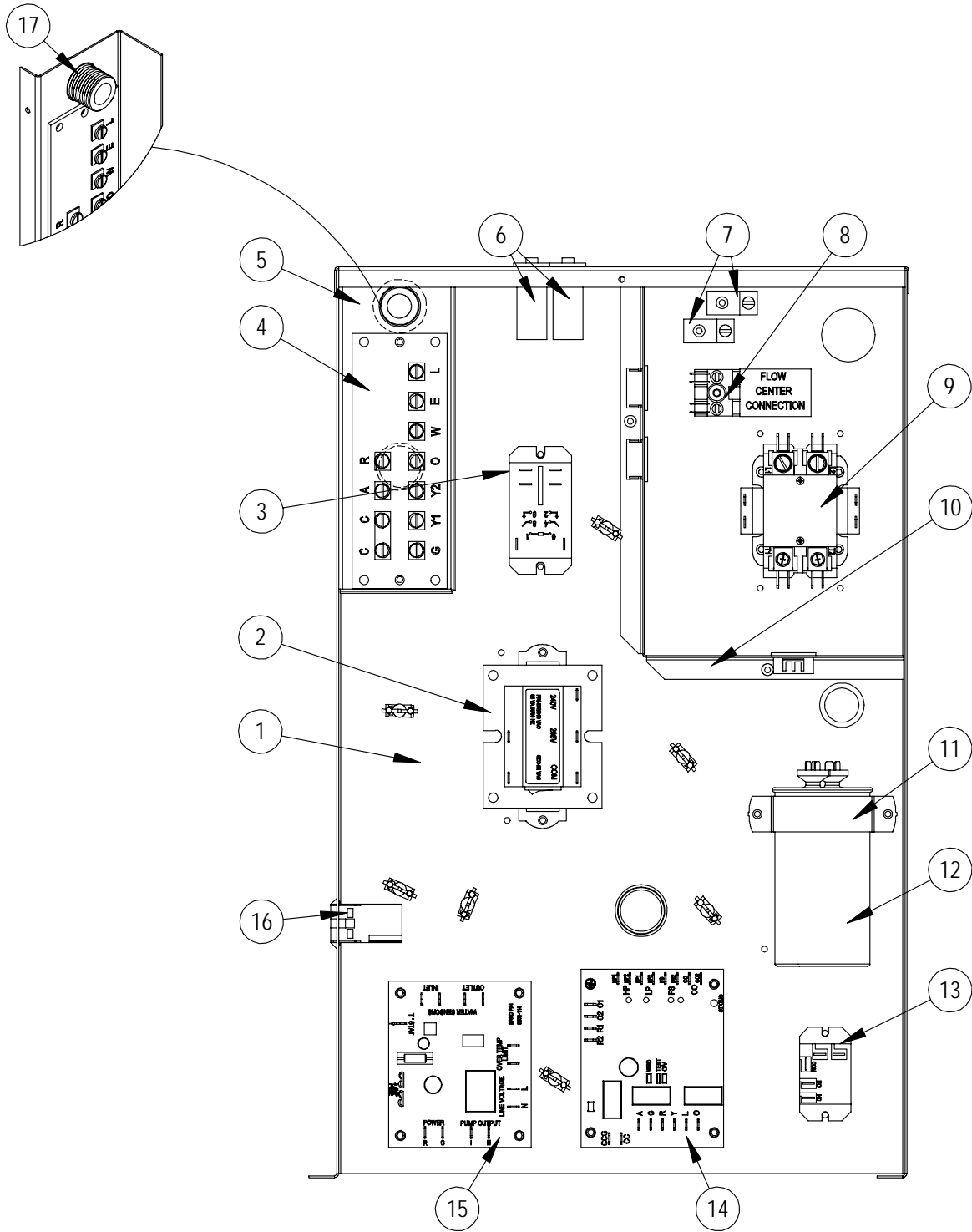

SEXP-664

CONTROL PANEL

Drawing No.	Part No.	Description	GW0241S1-A1R *CX	GW0361S1-A1R *CX	GW0481S1-A1R *CX	GW0601S1-A1R *CX	GW0701S1-A1R *CX
1	117-337	Control Panel	X	X	X	X	X
2	8407-048	75VA Transformer w/Circuit Breaker	X	X	X	X	X
3	8401-036	Flow Center Relay	X	X	X	X	X
4	8607-029	Low Voltage Terminal Strip	X	X	X	X	X
5	117-338	Low Voltage Partition	X	X	X	X	X
6	8614-036	Circuit Breaker 3A	2	2	2	2	2
7	8611-006	Grounding Terminal	2	2	2	2	2
8	8607-030	Flow Center Terminal Block	X	X	X	X	X
9	8401-033	Contactor 2-Pole 20A	X	X			
9	8401-034	Contactor 2-Pole 40A			X	X	X
10	117-339	Field Wire Barrier	X	X	X	X	X
11	8550-006	Capacitor Bracket	X		X		
11	8550-007	Capacitor Bracket		X		X	X
12	8552-086	Capacitor 35MFD 370V	X				
12	8552-035	Capacitor 40MFD 370V		X			
12	8552-095	Capacitor 30MFD 370V			X		
12	8552-096	Capacitor 40MFD 440V				X	X
13	8201-130	Flow Switch Bypass Relay	X	X	X	X	X
14	8201-140	Geothermal Logic Control	X	X	X	X	X
15	8201-114	Desuperheater Logic Control	X	X	X	X	X
16	3000-1353	Wire Assembly	X	X	X	X	X
17	8611-124	1/2" Snap Lock Fitting	X	X	X	X	X
NS	3000-1427	Compressor Power Harness	X	X	X	X	X
NS	3000-1436	Compressor Staging Solenoid Harness	X	X	X	X	X

* C = Copper Source Coil
 N = Cupronickel Source Coil