

REPLACEMENT PARTS MANUAL

WALL MOUNT GAS ELECTRICS MODELS WAG30A, WAG36A, WAG40A

Manual 2110-801

Revision E

Date 5-04-92

Supersedes 8-30-91

* GENERAL NOTES *

*Revised and/or additional pages may be issued from time to time.
*A complete and current manual consists of pages dated as shown in the following index.

** INDEX **

<u>Page Description</u>	<u>Page</u>	<u>Date</u>	<u>Supersedes</u>
Cabinet Components--Exploded View	1	2-19-90	7-11-89
" " --Usage List	2	2-19-90	7-11-89
Functional Components--Exploded View	3	2-19-90	1-25-90
" " --Usage List	4	5-04-92	8-30-91
Control Panel--Layout View	5	7-11-89	
" " --Usage List	6	7-11-89	

*** IMPORTANT ***

Contact the installing and/or local Bard distributor for all parts requirements. Make sure you have the complete model and serial number available from the unit rating plate.

BARD MANUFACTURING COMPANY

BRYAN, OHIO 43506

CABINET COMPONENTS

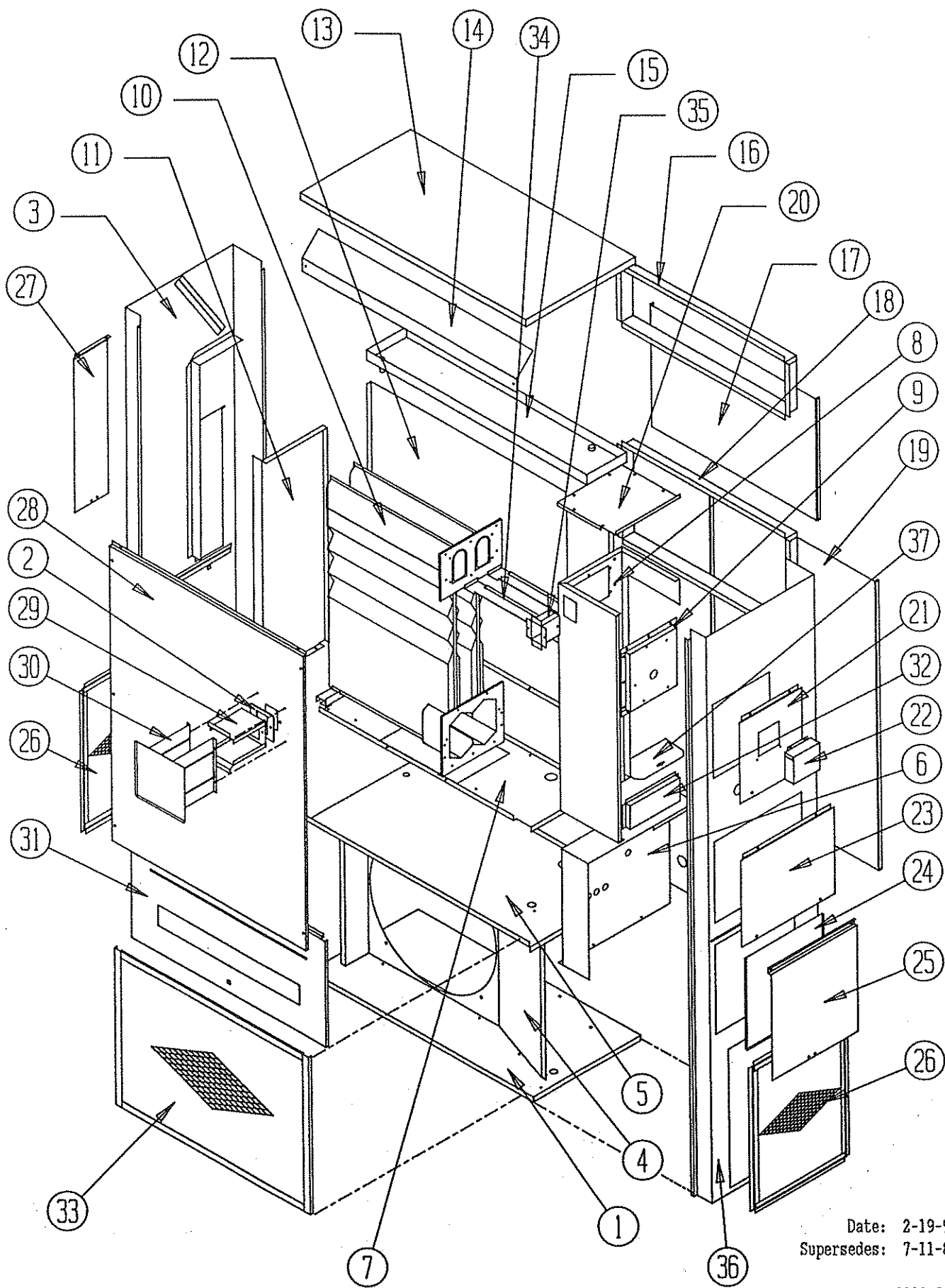

Date: 2-19-90
Supersedes: 7-11-89

CABINET COMPONENTS

Dwg. No.	Part No.	Description	WAG30AA54C	WAG30AA54C	WAG30AA54C	WAG30AA54C	WAG30AA54C	WAG30AA54C	WAG30AA54C
1	127-142	Lower Base	X	X	X	X	X	X	X
2	1921-017	Vent Term. Gasket	X	X	X	X	X	X	X
3	501-179	Left Side Assembly	X	X	X	X	X	X	X
4	124-016	Fan Shroud	X	X	X	X	X	X	X
5	520-108	Condenser Partition	X	X	X	X	X	X	X
6	Control Panel	(See Control Panel Assembly Drawing and Parts List)							
7	127-143	Blower Base	X	X	X	X	X	X	X
8	520-110	Heat Exchanger Partition	X	X	X	X	X	X	X
9	913-0018	Flue Collector Box Assembly	X	X	X	X	X	X	X
10	171-152	Heat Exchanger Assembly	X	X	X	X	X	X	X
11	520-111	Side Partition Assembly	X	X	X	X	X	X	X
12	520-109	Vertical Partition	X	X	X	X	X	X	X
13	506-107	Top	X	X	X	X	X	X	X
14	134-096	Air Baffle	X	X	X	X	X	X	X
15	123-067	Water Fan Assembly	X	X	X	X	X	X	X
16	111-025	Outlet Air Frame	X	X	X	X	X	X	X
17	508-056	Upper Back	X	X	X	X	X	X	X
18	111-018	Inlet Air Frame	X	X	X	X	X	X	X
19	508-069	Lower Back Assembly	X	X	X	X	X	X	X
20	506-108	Heat Exchanger Part. Top	X	X	X	X	X	X	X
21	552-138	Induced Blower Door	X	X	X	X	X	X	X
22	134-097	Induced Blower Hood	X	X	X	X	X	X	X
23	152-139	Burner Door	X	X	X	X	X	X	X
24	132-096	Inner Control Cover	X	X	X		X	X	
24	132-078	Inner Control Cover				X			X
25	152-136	Outer Control Cover	X	X	X	X	X	X	X
26	119-020	Side Condenser Grille	2	2	2	2	2	2	2
27	552-137	Filter Access	X	X	X	X	X	X	X
28	514-062	Upper Front	X	X	X	X	X	X	X
29	168-029	Inner Vent Term	X	X	X	X	X	X	X
30	169-030	Outer Vent Term	X	X	X	X	X	X	X
31	514-063	Lower Front	X	X	X	X	X	X	X
32	168-003	Secondary Air Baffle	X	X	X	X	X	X	X
33	119-003	Front Condenser Grille	X	X	X	X	X	X	X
34	168-002	Flue Baffle	2	2	2	2	2	2	2
35	169-026	Flue Transition	X	X	X	X	X	X	X
36	501-178	Right Side Assembly	X	X	X	X	X	X	X
37	140-164	Switch Support	X	X	X	X	X	X	X

Date: 2-19-90
Supersedes: 7-11-89

FUNCTIONAL COMPONENTS

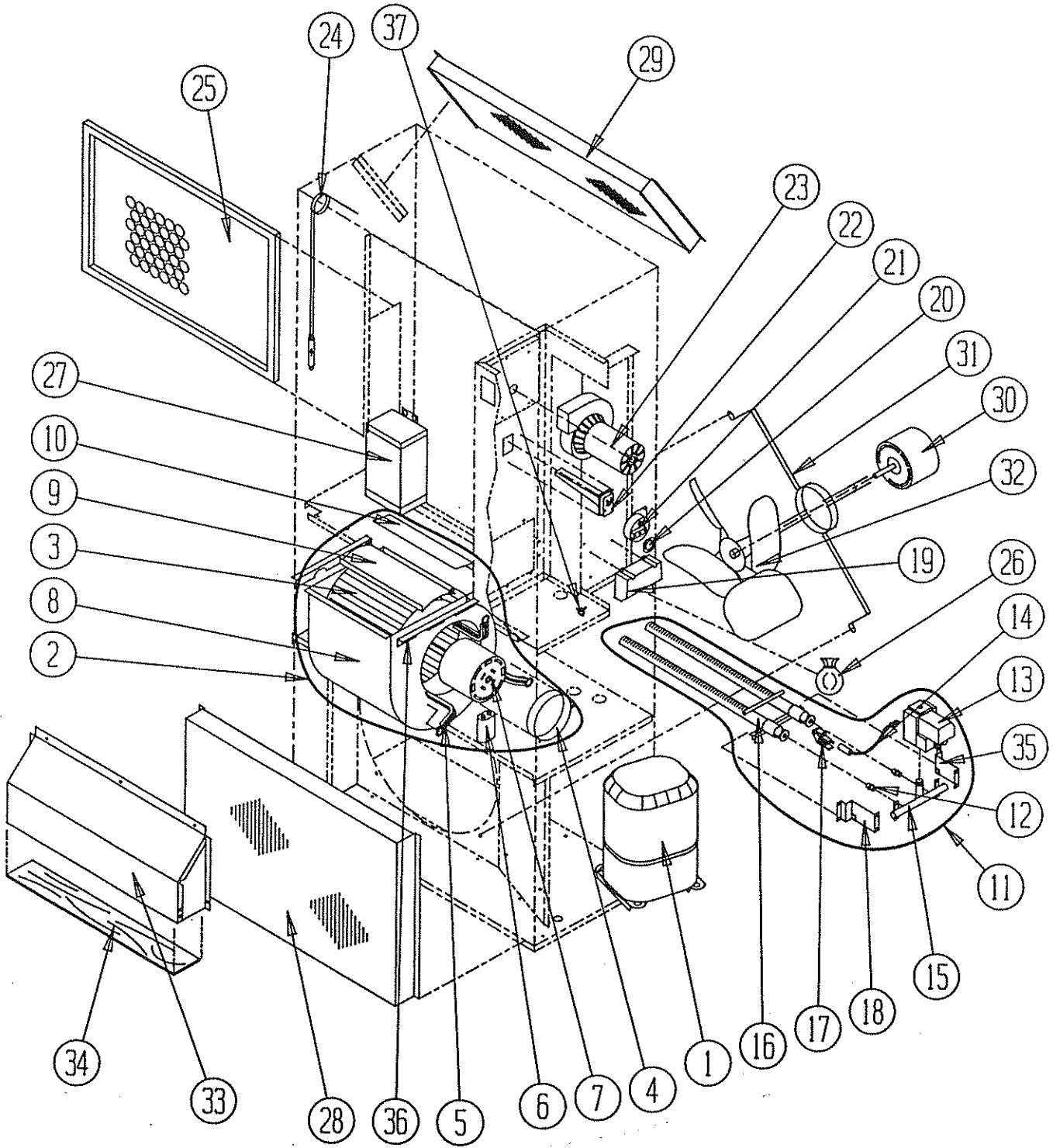

Date: 2-19-90
Supersedes: 1-25-90

FUNCTIONAL COMPONENTS

Dwg. No.	Part No.	Description	W A G 3 O A A 5 4 C	W A G 3 6 A A 5 4 C	W A G 3 6 A B 5 4 C	W A G 3 6 A C 5 4 C	W A G 4 O A A 5 4 C	W A G 4 O A B 5 4 C	W A G 4 O A C 5 4 C
1	8000-099	Compressor	X						
1	8000-055	Compressor		X					
1	8000-056	Compressor			X				
1	8000-057	Compressor				X			
1	8000-063	Compressor					X		
1	8000-064	Compressor						X	
1	8000-065	Compressor							X
2	900-123	Blower Assembly (Complete)	X	X	X	X	X	X	X
3	5152-059	Blower Wheel	X	X	X	X	X	X	X
4	8200-033	Motor Mount Band	X	X	X	X	X	X	X
5	8200-036	Motor Mount Arm	3	3	3	3	3	3	3
6	8552-002	Capacitor	X	X	X	X	X	X	X
7	8105-031	Blower Motor	X	X	X	X	X	X	X
8	151-083	Blower Housing	X	X	X	X	X	X	X
9	144-129	Diffuser	X	X	X	X	X	X	X
10	104-752	Blower Seal	X	X	X	X	X	X	X
11	901-0072	Burner Assembly (Complete)	X	X	X	X	X	X	X
12	9010-043	High Rate Orifice (Nat. #36)	2	2	2	2	2	2	2
13	5651-065	Gas Valve	X	X	X	X	X	X	X
14	8600-010	Ignition Wire	X	X	X	X	X	X	X
15	5818-023	Burner Manifold	X	X	X	X	X	X	X
16	9010-036	Burner (2 Cell)	X	X	X	X	X	X	X
17	8620-038	Pilot Burner	X	X	X	X	X	X	X
18	112Y095	Left Manifold Bracket	2	2	2	2	2	2	2
19	5651-093	Ignition Module	X	X	X	X	X	X	X
20	5451-015	Rubber Grommet	X	X	X	X	X	X	X
21	8406-052	Pressure Switch	X	X	X	X	X	X	X
22	8402-052	Limit Control	X	X	X	X	X	X	X
23	8109-002	Induced Draft Motor	X	X	X	X	X	X	X
24	800-0128	Capillary Assembly	X						
24	800-0129	Capillary Assembly		X	X	X			
24	800-0130	Capillary Assembly					X	X	X
25	7004-016	Air Filter	X	X	X	X	X	X	X
26	400-0027	Low Rate Orifice Kit (Nat. #40)	X	X	X	X	X	X	X
27	8407-003	460V Transformer				X			X
28	5051-035	Condenser Coil	X						
28	5051-054	Condenser Coil		X	X	X	X	X	X
29	5060-037	Evaporator Coil	X						
29	5060-050	Evaporator Coil		X	X	X	X	X	X
30	8103-019	Condenser Motor	X						
30	8105-034	Condenser Motor		X	X	X	X	X	X
31	8200-037	Fan Motor Mount	X	X	X	X	X	X	X
32	5151-038	Fan Blade	X						
32	5151-028	Fan Blade		X	X	X	X	X	X
33	913-0020	Fresh Air Damper Assembly	X	X	X	X	X	X	X
34	7003-019	Air Filter	X	X	X	X	X	X	X
35	112X095	Right Manifold Bracket	X	X	X	X	X	X	X
36	104-791	Blower Angles	2	2	2	2	2	2	2
37	8406-046	Flame Rollout Switch	X	X	X	X	X	X	X
	8620-040	Pilot Gas Tube With Fittings	X	X	X	X	X	X	X
	5153-030	Tee/Orifice Assembly	X	X	X	X	X	X	X

Date: 05-04-92
 Supersedes: 08-30-91
 2110-801
 Page: 4

CONTROL PANEL

Dwg. No.	Part No.	Description	W	W	W	W	W	W	W
			A	A	A	A	A	A	A
			G	G	G	G	G	G	G
			3	3	3	3	4	4	4
			0	6	6	6	0	0	0
			A	A	A	A	A	A	A
			A	A	B	C	A	B	C
			5	5	5	5	5	5	5
			4	4	4	4	4	4	4
			C	C	C	C	C	C	C
1	8201-053	Blower Control	x	x	x	x	x	x	x
2	8401-007	Contactoer Coil	x	x			x		
2	8401-002	Contactoer Coil			x	x		x	x
3	8407-034	Transformer	x	x	x	x	x	x	x
4	8615-009	Circuit Breaker	x						
4	8615-014	Circuit Breaker		x					
4	8615-018	Circuit Breaker			x				
4	8615-023	Circuit Breaker				x			
4	8615-015	Circuit Breaker					x		
4	8615-019	Circuit Breaker						x	
4	8615-024	Circuit Breaker							x
5	8201-008	Outdoor Fan Relay				x			x
6	8552-002	Fan Capacitor	x						
6	8552-005	Fan Capacitor		x	x	x	x	x	x
7	8552-032	Compressor Capacitor	x						
7	8552-035	Compressor Capacitor		x					
7	8552-030	Compressor Capacitor					x		
8		Low Voltage Kit	<----Field Installed---->						
9		Compressor Anti Cycle Relay	<----Field Installed---->						
	4085-110	Wiring Diagram	x	x			x		
	4085-210	Wiring Diagram			x			x	
	4085-310	Wiring Diagram				x			x

Date: 7-11-89
Supersedes: