Replacement Parts Manual

WALL MOUNTED GAS/ELECTRIC

MODEL: **WG421**
WG481
WG601

General Notes

- Revised and/or additional pages may be issued from time to time.
- A complete and current manual consists of pages shown in the following contents section.

Important

- Contact the installing and/or local Bard distributor for all parts requirements. Make sure you have the complete model and serial number available from the unit rating plates.

Contents

<i>Description</i>	<i>Page</i>
Cabinet Components	
♦ Exploded View	1
♦ Usage List	2
♦ Usage List	3
♦ Usage List	4
♦ Usage List	5
♦ Usage List	6
♦ Usage List	7
♦ Blank Page	8
Functional Components	
♦ Exploded View	9
♦ Usage List	10
♦ Usage List	11
♦ Usage List	12
Functional Components	
♦ Exploded View	13
♦ Usage List	14
♦ Usage List	15
♦ Usage List	16
Control Panel	
♦ Layout	17
♦ Usage List	18
Blower Assembly	
♦ Exploded View	19
♦ Usage List	19



BARD MANUFACTURING COMPANY
Bryan, Ohio 43506

Since 1914...Moving ahead, just as planned.

Manual: 2110-803B
Supersedes: 2110-803A
File: Vol. III Tab 20
Date: 09-20-2000

CABINET COMPONENTS

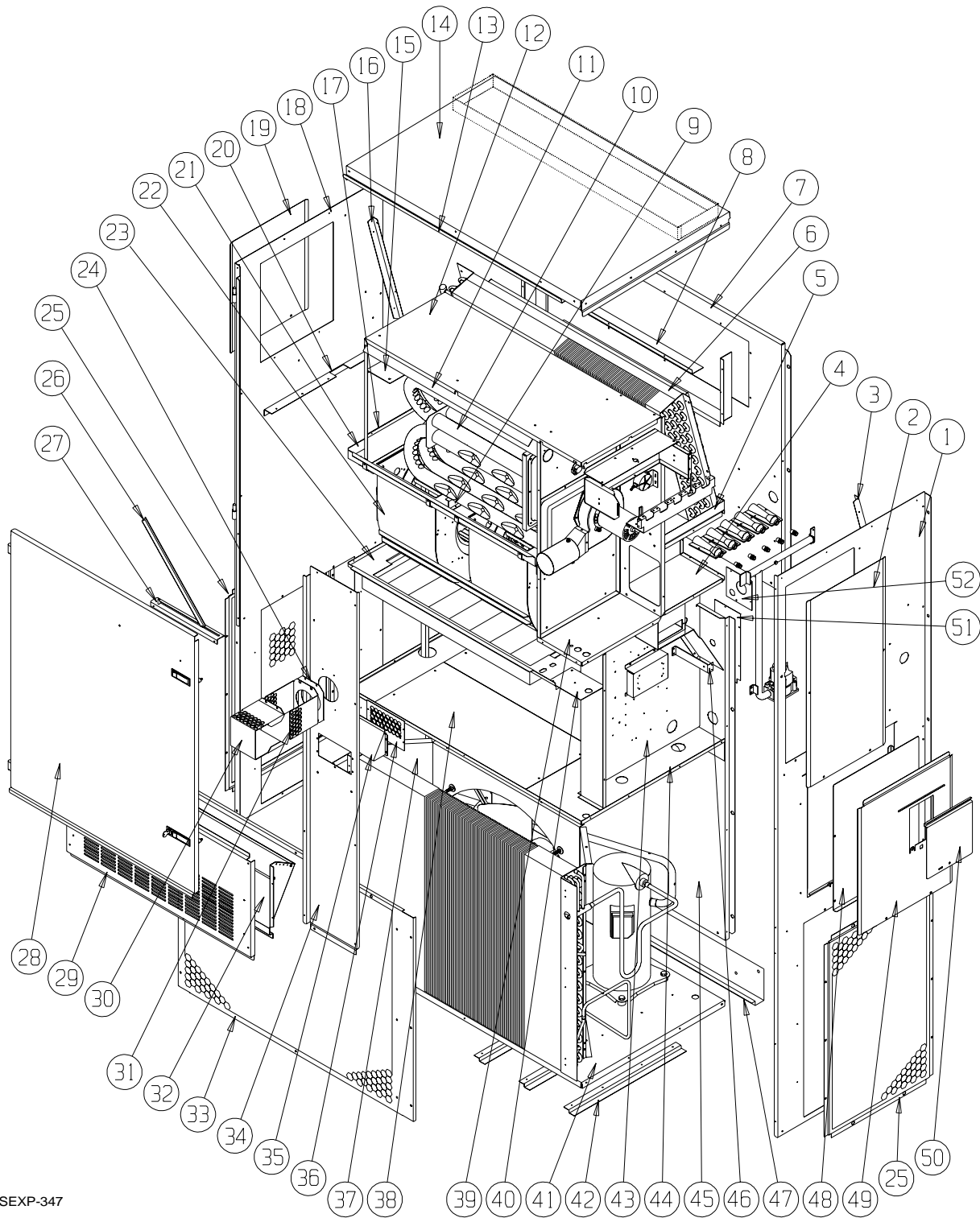

SEXP-347

This drawing to be used for reference for Pages 2, 3, 4, 5, 6 and 7.

CABINET COMPONENTS

Dwg No.	Part No.	Description	WG421-AXB	WG421-AXC	WG421-AXD	WG421-BXB	WG421-BXC	WG421-BXD	WG421-CXB	WG421-CXC	WG421-CXD
1	501-376-*	Right Side Assembly	X	X	X	X	X	X	X	X	X
2	S153-326-*	Vestibule Service Door	X	X	X	X	X	X	X	X	X
3	105X1076	Right Evaporator Support Angle	X	X	X	X	X	X	X	X	X
4	541-266	Right Drain Pan Support Assembly	X	X	X	X	X	X	X	X	X
5	523-103	Drain Pan Assembly	X	X	X	X	X	X	X	X	X
6	105-1080	Evaporator Coil Fill Angle	X	X	X	X	X	X	X	X	X
7	509-156	Upper Back	X	X	X	X	X	X	X	X	X
8	111-063	Supply Air Frame	2	2	2	2	2	2	2	2	2
9	103-439	Heat Exchanger Support Offset	X	X	X	X	X	X	X	X	X
10	Heat Exch Assy	See Burner Components Diagram									
11	105-1076	Top Heat Exchanger Deflector	X	X	X	X	X	X	X	X	X
12	135-183	Inner Air Baffle	X	X	X	X	X	X	X	X	X
13	165-563-*	Top Rain Channel	X	X	X	X	X	X	X	X	X
14	507-219-*	Top Assembly	X	X	X	X	X	X	X	X	X
15	135-184	Right Heat Exchanger Deflector	X	X	X	X	X	X	X	X	X
16	105Y1073	Left Evaporator Support Angle	X	X	X	X	X	X	X	X	X
17	105-1066	Lower Heat Exchanger Deflector	X	X	X	X	X	X	X	X	X
18	501-377-*	Left Side Assembly	X	X	X	X	X	X	X	X	X
19	543-070-*	Left Access Cover	X	X	X	X	X	X	X	X	X
20	105-1070	Left Support Angle	X	X	X	X	X	X	X	X	X
21	121-337	Blower Partition	X	X	X	X	X	X	X	X	X
22	900-249	Complete Blower Assembly - 230V	X	X	X	X	X				
22	900-251	Complete Blower Assembly - 460V							X	X	X
23	131-134	Filter Tray	X	X	X	X	X	X	X	X	X
24	168-121	Vent Plate	X	X	X	X	X	X	X	X	X
25	118-032-*	Side Grille	2	2	2	2	2	2	2	2	2
26	105-1068	Door Stop Angle	X	X	X	X	X	X	X	X	X
Continued on page 3											

* Exterior cabinet parts are manufactured with various paint color options. To insure that you receive the proper paint color, you must include the complete model and serial number of the unit for which cabinet parts are being ordered.

Refer to drawing on Page 1

CABINET COMPONENTS

Dwg No.	Part No.	Description	WG421-AXB	WG421-AXC	WG421-AXD	WG421-BXB	WG421-BXC	WG421-BXD	WG421-CXB	WG421-CXC	WG421-CXD
Continued from Page 2											
27	105-1069	Door Stop Slide	X	X	X	X	X	X	X	X	X
28	553-325-*	Front Door Assembly	X	X	X	X	X	X	X	X	X
29	553-327-*	Vent Option Door Assembly	X	X	X	X	X	X	X	X	X
30	169-119	Outer Vent Hood	X	X	X	X	X	X	X	X	X
31	169-120	Inner Vent Hood	X	X	X	X	X	X	X	X	X
32	538-135	Barometric Fresh Air Damper	X	X	X	X	X	X	X	X	X
33	118-031-*	Condenser Grille	X	X	X	X	X	X	X	X	X
34	549-095-*	Right Front Corner Assembly	X	X	X	X	X	X	X	X	X
35	135-181-*	Air Intake Hood	X	X	X	X	X	X	X	X	X
36	134-182-*	Air Intake Back	X	X	X	X	X	X	X	X	X
37	125-036	Fan Shroud	X	X	X	X	X	X	X	X	X
38	542-072	Condenser Partition Blank Off Plate	2	2	2	2	2	2	2	2	2
39	541-267	Heat Exchanger Support Assembly	X	X	X	X	X	X	X	X	X
40	142-071	Filter Blank Off Plate	X	X	X	X	X	X	X	X	X
41	127-302	Lower Base	X	X	X	X	X	X	X	X	X
42	103-438	Lower Base Offset	3	3	3	3	3	3	3	3	3
43	902-1092	Control Panel Assembly	X	X	X						
43	902-1093	Control Panel Assembly				X	X	X			
43	902-1094	Control Panel Assembly							X	X	X
44	521-338	Condenser Partition Assembly	X	X	X	X	X	X	X	X	X
45	509-157	Lower Back Assembly	X	X	X	X	X	X	X	X	X
46	113-268	Manifold Bracket	X	X	X	X	X	X	X	X	X
47	113-140	Bottom Support Bracket	X	X	X	X	X	X	X	X	X
48	113-163	Control Panel Cover (Inner)	X	X	X	X	X	X	X	X	X
49	S533-16	Control Panel Cover Assembly	X	X	X	X	X	X	X	X	X
50	153-328-*	Disconnect Access Door	X	X	X	X	X	X	X	X	X
51	134-193	Conduit Access Panel	X	X	X	X	X	X	X	X	X
52	156-029	Conduit Entrance Plate	X	X	X	X	X	X	X	X	X

* Exterior cabinet parts are manufactured with various paint color options. To insure that you receive the proper paint color, you must include the complete model and serial number of the unit for which cabinet parts are being ordered.

Refer to drawing on Page 1

CABINET COMPONENTS

Dwg No.	Part No.	Description	WG481-AXB	WG481-AXC	WG481-AXD	WG481-BXB	WG481-BXC	WG481-BXD	WG481-CXB	WG481-CXC	WG481-CXD
1	501-376-*	Right Side Assembly	X	X	X	X	X	X	X	X	X
2	S153-326-*	Vestibule Service Door	X	X	X	X	X	X	X	X	X
3	105X1076	Right Evaporator Support Angle	X	X	X	X	X	X	X	X	X
4	541-266	Right Drain Pan Support Assembly	X	X	X	X	X	X	X	X	X
5	523-103	Drain Pan Assembly	X	X	X	X	X	X	X	X	X
6	105-1080	Evaporator Coil Fill Angle	X	X	X	X	X	X	X	X	X
7	509-156	Upper Back	X	X	X	X	X	X	X	X	X
8	111-063	Supply Air Frame	2	2	2	2	2	2	2	2	2
9	103-439	Heat Exchanger Support Offset	X	X	X	X	X	X	X	X	X
10	Heat Exch Assy	See Burner Components Diagram									
11	105-1076	Top Heat Exchanger Deflector	X	X	X	X	X	X	X	X	X
12	135-183	Inner Air Baffle	X	X	X	X	X	X	X	X	X
13	165-563-*	Top Rain Channel	X	X	X	X	X	X	X	X	X
14	507-219-*	Top Assembly	X	X	X	X	X	X	X	X	X
15	135-184	Right Heat Exchanger Deflector	X	X	X	X	X	X	X	X	X
16	105Y1073	Left Evaporator Support Angle	X	X	X	X	X	X	X	X	X
17	105-1066	Lower Heat Exchanger Deflector	X	X	X	X	X	X	X	X	X
18	501-377-*	Left Side Assembly	X	X	X	X	X	X	X	X	X
19	543-070-*	Left Access Cover	X	X	X	X	X	X	X	X	X
20	105-1070	Left Support Angle	X	X	X	X	X	X	X	X	X
21	121-337	Blower Partition	X	X	X	X	X	X	X	X	X
22	900-249	Complete Blower Assembly - 230V	X	X	X	X	X				
22	900-251	Complete Blower Assembly - 460V							X	X	X
23	131-134	Filter Tray	X	X	X	X	X	X	X	X	X
24	168-121	Vent Plate	X	X	X	X	X	X	X	X	X
25	118-032-*	Side Grille	2	2	2	2	2	2	2	2	2
26	105-1068	Door Stop Angle	X	X	X	X	X	X	X	X	X

Continued on page 5

* Exterior cabinet parts are manufactured with various paint color options. To insure that you receive the proper paint color, you must include the complete model and serial number of the unit for which cabinet parts are being ordered.

Refer to drawing on Page 1

CABINET COMPONENTS

Dwg No.	Part No.	Description	WG481-AXB	WG481-AXC	WG481-AXD	WG481-BXB	WG481-BXC	WG481-BXD	WG481-CXB	WG481-CXC	WG481-CXD
Continued from Page 4											
27	105-1069	Door Stop Slide	X	X	X	X	X	X	X	X	X
28	553-325-*	Front Door Assembly	X	X	X	X	X	X	X	X	X
29	553-327-*	Vent Option Door Assembly	X	X	X	X	X	X	X	X	X
30	169-119	Outer Vent Hood	X	X	X	X	X	X	X	X	X
31	169-120	Inner Vent Hood	X	X	X	X	X	X	X	X	X
32	538-135	Barometric Fresh Air Damper	X	X	X	X	X	X	X	X	X
33	118-031-*	Condenser Grille	X	X	X	X	X	X	X	X	X
34	549-095-*	Right Front Corner Assembly	X	X	X	X	X	X	X	X	X
35	135-181-*	Air Intake Hood	X	X	X	X	X	X	X	X	X
36	134-182-*	Air Intake Back	X	X	X	X	X	X	X	X	X
37	125-036	Fan Shroud	X	X	X	X	X	X	X	X	X
38	542-072	Condenser Partition Blank Off Plate	2	2	2	2	2	2	2	2	2
39	541-267	Heat Exchanger Support Assembly	X	X	X	X	X	X	X	X	X
40	142-071	Filter Blank Off Plate	X	X	X	X	X	X	X	X	X
41	127-302	Lower Base	X	X	X	X	X	X	X	X	X
42	103-438	Lower Base Offset	3	3	3	3	3	3	3	3	3
43	902-1095	Control Panel Assembly	X	X	X						
43	902-1096	Control Panel Assembly				X	X	X			
43	902-1097	Control Panel Assembly							X	X	X
44	521-338	Condenser Partition Assembly	X	X	X	X	X	X	X	X	X
45	509-157	Lower Back Assembly	X	X	X	X	X	X	X	X	X
46	113-268	Manifold Bracket	X	X	X	X	X	X	X	X	X
47	113-140	Bottom Support Bracket	X	X	X	X	X	X	X	X	X
48	113-163	Control Panel Cover (Inner)	X	X	X	X	X	X	X	X	X
49	S533-10	Control Panel Cover Assembly	X	X	X	X	X	X	X	X	X
50	153-328-*	Disconnect Access Door	X	X	X	X	X	X	X	X	X
51	134-193	Conduit Access Panel	X	X	X	X	X	X	X	X	X
52	156-029	Conduit Entrance Plate	X	X	X	X	X	X	X	X	X

* Exterior cabinet parts are manufactured with various paint color options. To insure that you receive the proper paint color, you must include the complete model and serial number of the unit for which cabinet parts are being ordered.

Refer to drawing on Page 1

CABINET COMPONENTS

Dwg No.	Part No.	Description	WG601-AXB	WG601-AXC	WG601-AXD	WG601-BXB	WG601-BXC	WG601-BXD	WG601-CXB	WG601-CXC	WG601-CXD
1	501-376-*	Right Side Assembly	X	X	X	X	X	X	X	X	X
2	S153-326-*	Vestibule Service Door	X	X	X	X	X	X	X	X	X
3	105X1076	Right Evaporator Support Angle	X	X	X	X	X	X	X	X	X
4	541-266	Right Drain Pan Support Assembly	X	X	X	X	X	X	X	X	X
5	523-103	Drain Pan Assembly	X	X	X	X	X	X	X	X	X
6	105-1080	Evaporator Coil Fill Angle	X	X	X	X	X	X	X	X	X
7	509-156	Upper Back	X	X	X	X	X	X	X	X	X
8	111-063	Supply Air Frame	2	2	2	2	2	2	2	2	2
9	103-439	Heat Exchanger Support Offset	X	X	X	X	X	X	X	X	X
10	Heat Exch Assy See Burner Components Diagram										
11	105-1076	Top Heat Exchanger Deflector	X	X	X	X	X	X	X	X	X
12	135-183	Inner Air Baffle	X	X	X	X	X	X	X	X	X
13	165-563-*	Top Rain Channel	X	X	X	X	X	X	X	X	X
14	507-219-*	Top Assembly	X	X	X	X	X	X	X	X	X
15	135-184	Right Heat Exchanger Deflector	X	X	X	X	X	X	X	X	X
16	105Y1073	Left Evaporator Support Angle	X	X	X	X	X	X	X	X	X
17	105-1066	Lower Heat Exchanger Deflector	X	X	X	X	X	X	X	X	X
18	501-377-*	Left Side Assembly	X	X	X	X	X	X	X	X	X
19	543-070-*	Left Access Cover	X	X	X	X	X	X	X	X	X
20	105-1070	Left Support Angle	X	X	X	X	X	X	X	X	X
21	121-337	Blower Partition	X	X	X	X	X	X	X	X	X
22	900-249	Complete Blower Assembly - 230V	X	X	X	X	X				
22	900-251	Complete Blower Assembly - 460V							X	X	X
23	131-134	Filter Tray	X	X	X	X	X	X	X	X	X
24	168-121	Vent Plate	X	X	X	X	X	X	X	X	X
25	118-032-*	Side Grille	2	2	2	2	2	2	2	2	2
26	105-1068	Door Stop Angle	X	X	X	X	X	X	X	X	X

Continued on page 7

* Exterior cabinet parts are manufactured with various paint color options. To insure that you receive the proper paint color, you must include the complete model and serial number of the unit for which cabinet parts are being ordered.

Refer to drawing on Page 1

CABINET COMPONENTS

Dwg No.	Part No.	Description	WG601-AXB	WG601-AXC	WG601-AXD	WG601-BXB	WG601-BXC	WG601-BXD	WG601-CXB	WG601-CXC	WG601-CXD
Continued from Page 6											
27	105-1069	Door Stop Slide	X	X	X	X	X	X	X	X	X
28	553-325-*	Front Door Assembly	X	X	X	X	X	X	X	X	X
29	553-327-*	Vent Option Dor Assembly	X	X	X	X	X	X	X	X	X
30	169-119	Outer Vent Hood	X	X	X	X	X	X	X	X	X
31	169-120	Inner Vent Hood	X	X	X	X	X	X	X	X	X
32	538-135	Barometric Fresh Air Damper	X	X	X	X	X	X	X	X	X
33	118-031-*	Condenser Grille	X	X	X	X	X	X	X	X	X
34	549-095-*	Right Front Corner Assembly	X	X	X	X	X	X	X	X	X
35	135-181-*	Air Intake Hood	X	X	X	X	X	X	X	X	X
36	134-182-*	Air Intake Back	X	X	X	X	X	X	X	X	X
37	125-036	Fan Shroud	X	X	X	X	X	X	X	X	X
38	542-072	Condenser Partition Blank Off Plate	2	2	2	2	2	2	2	2	2
39	541-267	Heat Exchanger Support Assembly	X	X	X	X	X	X	X	X	X
40	142-071	Filter Blank Off Plate	X	X	X	X	X	X	X	X	X
41	127-302	Lower Base	X	X	X	X	X	X	X	X	X
42	103-438	Lower Base Offset	3	3	3	3	3	3	3	3	3
43	902-1098	Control Panel Assembly	X	X	X						
43	902-1099	Control Panel Assembly				X	X	X			
43	902-1100	Control Panel Assembly							X	X	X
44	521-338	Condenser Partition Assembly	X	X	X	X	X	X	X	X	X
45	509-157	Lower Back Assembly	X	X	X	X	X	X	X	X	X
46	113-268	Manifold Bracket	X	X	X	X	X	X	X	X	X
47	113-140	Bottom Support Bracket	X	X	X	X	X	X	X	X	X
48	113-163	Control Panel Cover (Inner)	X	X	X	X	X	X	X	X	X
49	S533-16	Control Panel Cover Assembly	X	X	X	X	X	X	X	X	X
50	153-328-*	Disconnect Access Door	X	X	X	X	X	X	X	X	X
51	134-193	Conduit Access Panel	X	X	X	X	X	X	X	X	X
52	156-029	Conduit Entrance Plate	X	X	X	X	X	X	X	X	X

* Exterior cabinet parts are manufactured with various paint color options. To insure that you receive the proper paint color, you must include the complete model and serial number of the unit for which cabinet parts are being ordered.

Refer to drawing on Page 1

This page left blank intentionally

SEXP-306

FUNCTIONAL COMPONENTS

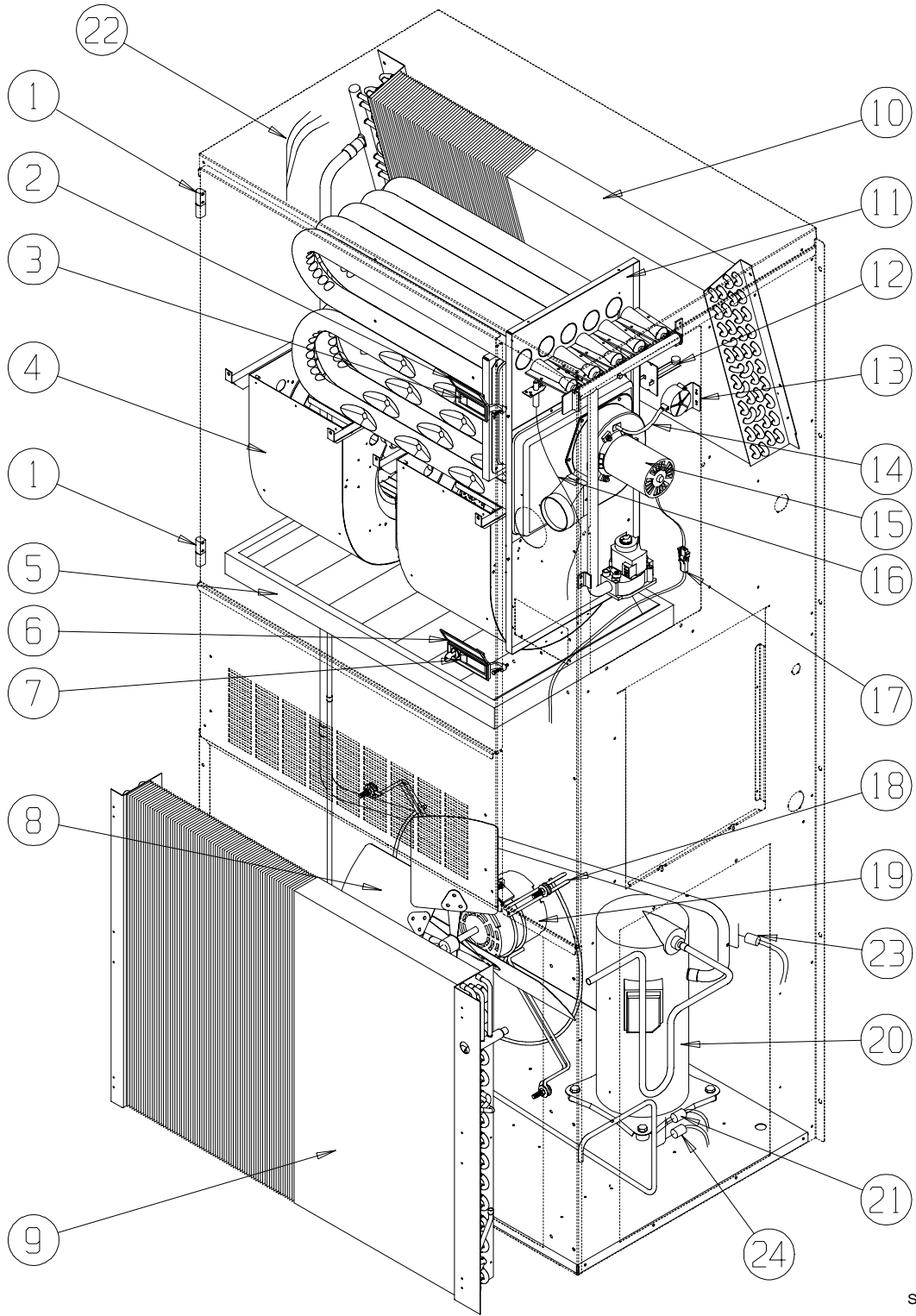

SEXP-348

This drawing to be used for reference for Pages 10, 11 and 12.

FUNCTIONAL COMPONENTS

Dwg No.	Part No.	Description	WG421-AXB	WG421-AXC	WG421-AXD	WG421-BXB	WG421-BXC	WG421-BXD	WG421-CXB	WG421-CXC	WG421-CXD
1	5400-005	Metal Lift-Off Hinge	2	2	2	2	2	2	2	2	2
2	1171-050	Weather Cover for Latch 1171-048	X	X	X	X	X	X	X	X	X
3	1171-048	Black Non-Lockable Latch	X	X	X	X	X	X	X	X	X
4	900-249	Complete Blower Assembly 230/208	X	X	X	X	X	X			
4	900-251	Complete Blower Assembly 460V							X	X	X
5	7004-027	20 x 30 x 2 Pleated Filter (standard)	X	X	X	X	X	X	X	X	X
5	7003-030	20 x 30 x 1 AF Filter (optional)	X	X	X	X	X	X	X	X	X
6	1171-051	Weather Cover for Latch 1171-049	X	X	X	X	X	X	X	X	X
7	1171-049	Black Lockable Latch	X	X	X	X	X	X	X	X	X
8	5151-054	Fan Blade	X	X	X	X	X	X	X	X	X
9	5051-078	Coil	X	X	X	X	X	X	X	X	X
10	5060-106	Coil	X	X	X	X	X	X	X	X	X
11	Heat Exch.	See Burner Components Diagram	X	X	X	X	X	X	X	X	X
12	8402-123	Limit Control L180-30 3"	X	X		X	X		X	X	
12	8402-126	Limit Control L200-30 3"			X			X			X
13	8406-103	.55" ± .05" Pressure Switch	X	X	X	X	X	X	X	X	X
15	8109-012	Induced Draft Blower 230V	X	X	X	X	X	X			
15	8109-013	Induced Draft Blower 460V							X	X	X
16	8600-011	Suppression Ignition Cable	X	X	X	X	X	X	X	X	X
17	3000-1121	Wire Assembly	X	X	X	X	X	X			
17	3000-1124	Wire Assembly							X	X	X
18	8200-004	Fan Motor Mount	X	X	X	X	X	X	X	X	X
19	8105-039	Motor 230/208V	X	X	X	X	X	X			
19	8105-030	Motor 460V							X	X	X
20	8000-126	Compressor CR42K6-PFV	X	X	X						
20	8000-127	Compressor CR42K6-TF5				X	X	X			
20	8000-128	Compressor CR42K6-TFD							X	X	X
21	1804-0106	High Pressure Switch (Flare)	X	X	X	X	X	X	X	X	X
22	5625-038	Distributor/Orifice .078	X	X	X	X	X	X	X	X	X
23	1804-0107	Low Pressure Switch - Opt. - (Flare)	X	X	X	X	X	X	X	X	X
24	CMA-6	Low Ambient Control - Opt. - (Flare)	X	X	X	X	X	X	X	X	X

Opt. = Optional

Refer to drawing on Page 9

FUNCTIONAL COMPONENTS

Dwg No.	Part No.	Description	WG481-AXB	WG481-AXC	WG481-AXD	WG481-BXB	WG481-BXC	WG481-BXD	WG481-CXB	WG481-CXC	WG481-CXD
1	5400-005	Metal Lift-Off Hinge	2	2	2	2	2	2	2	2	2
2	1171-050	Weather Cover for Latch 1171-048	X	X	X	X	X	X	X	X	X
3	1171-048	Black Non-Lockable Latch	X	X	X	X	X	X	X	X	X
4	900-249	Complete Blower Assembly 230/208	X	X	X	X	X	X			
4	900-251	Complete Blower Assembly 460V							X	X	X
5	7004-027	20 x 30 x 2 Pleated Filter (standard)	X	X	X	X	X	X	X	X	X
5	7003-030	20 x 30 x 1 AF Filter (optional)	X	X	X	X	X	X	X	X	X
6	1171-051	Weather Cover for Latch 1171-049	X	X	X	X	X	X	X	X	X
7	1171-049	Black Lockable Latch	X	X	X	X	X	X	X	X	X
8	5151-054	Fan Blade	X	X	X	X	X	X	X	X	X
9	5051-074	Coil	X	X	X	X	X	X	X	X	X
10	5060-106	Coil	X	X	X	X	X	X	X	X	X
11	Heat Exch.	See Burner Components Diagram	X	X	X	X	X	X	X	X	X
12	8402-123	Limit Control L180-30 3"	X	X		X	X		X	X	
12	8402-126	Limit Control L200-30 3"			X			X			X
13	8406-103	.55" ± .05" Pressure Switch	X	X	X	X	X	X	X	X	X
15	8109-012	Induced Draft Blower 230V	X	X	X	X	X	X			
15	8109-013	Induced Draft Blower 460V							X	X	X
16	8600-011	Suppression Ignition Cable	X	X	X	X	X	X	X	X	X
17	3000-1121	Wire Assembly	X	X	X	X	X	X			
17	3000-1124	Wire Assembly							X	X	X
18	8200-004	Fan Motor Mount	X	X	X	X	X	X	X	X	X
19	8105-039	Motor 230/208V	X	X	X	X	X	X			
19	8105-030	Motor 460V							X	X	X
20	8000-236	Compressor ZR47KC-PFV	X	X	X						
20	8000-221	Compressor ZR47KC-TF5				X	X	X			
20	8000-222	Compressor ZR47KC-TFD							X	X	X
21	1804-0106	High Pressure Switch (Flare)	X	X	X	X	X	X	X	X	X
22	5625-038	 Distributor/Orifice .084	X	X	X	X	X	X	X	X	X
23	1804-0107	Low Pressure Switch - Opt. - (Flare)	X	X	X	X	X	X	X	X	X
24	CMA-6	Low Ambient Control - Opt. - (Flare)	X	X	X	X	X	X	X	X	X

Opt. = Optional

Refer to drawing on Page 9

FUNCTIONAL COMPONENTS

Dwg No.	Part No.	Description	WG601-AXB	WG601-AXC	WG601-AXD	WG601-BXB	WG601-BXC	WG601-BXD	WG601-CXB	WG601-CXC	WG601-CXD
1	5400-005	Metal Lift-Off Hinge	2	2	2	2	2	2	2	2	2
2	1171-050	Weather Cover for Latch 1171-048	X	X	X	X	X	X	X	X	X
3	1171-048	Black Non-Lockable Latch	X	X	X	X	X	X	X	X	X
4	900-249	Complete Blower Assembly 230/208	X	X	X	X	X	X			
4	900-251	Complete Blower Assembly 460V							X	X	X
5	7004-027	20 x 30 x 2 Pleated Filter (standard)	X	X	X	X	X	X	X	X	X
5	7003-030	20 x 30 x 1 AF Filter (optional)	X	X	X	X	X	X	X	X	X
6	1171-051	Weather Cover for Latch 1171-049	X	X	X	X	X	X	X	X	X
7	1171-049	Black Lockable Latch	X	X	X	X	X	X	X	X	X
8	5151-054	Fan Blade	X	X	X	X	X	X	X	X	X
9	5051-074	Coil	X	X	X	X	X	X	X	X	X
10	5060-105	Coil	X	X	X	X	X	X	X	X	X
11	Heat Exch.	See Burner Components Diagram	X	X	X	X	X	X	X	X	X
12	8402-123	Limit Control L180-30 3"	X	X		X	X		X	X	
12	8402-126	Limit Control L200-30 3"			X			X			X
13	8406-103	.55" ± .05" Pressure Switch	X	X	X	X	X	X	X	X	X
15	8109-012	Induced Draft Blower 230V	X	X	X	X	X	X			
15	8109-013	Induced Draft Blower 460V							X	X	X
16	8600-011	Suppression Ignition Cable	X	X	X	X	X	X	X	X	X
17	3000-1121	Wire Assembly	X	X	X	X	X	X			
17	3000-1124	Wire Assembly							X	X	X
18	8200-004	Fan Motor Mount	X	X	X	X	X	X	X	X	X
19	8105-039	Motor 230/208V	X	X	X	X	X	X			
19	8105-030	Motor 460V							X	X	X
20	8000-153	Compressor ZR61K3-PFV	X	X	X						
20	8000-154	Compressor ZR61K3-TF5				X	X	X			
20	8000-155	Compressor ZR61K3-TFD							X	X	X
21	1804-0106	High Pressure Switch Flare	X	X	X	X	X	X	X	X	X
22	5625-038	Distributor/Orifice .089	X	X	X	X	X	X	X	X	X
23	1804-010	Low Pressure Switch - Opt. - (Flare)	X	X	X	X	X	X	X	X	X
24	CMA-6	Low Ambient Control - Opt. - (Flare)	X	X	X	X	X	X	X	X	X

Opt. = Optional

Refer to drawing on Page 9

BURNER COMPONENTS

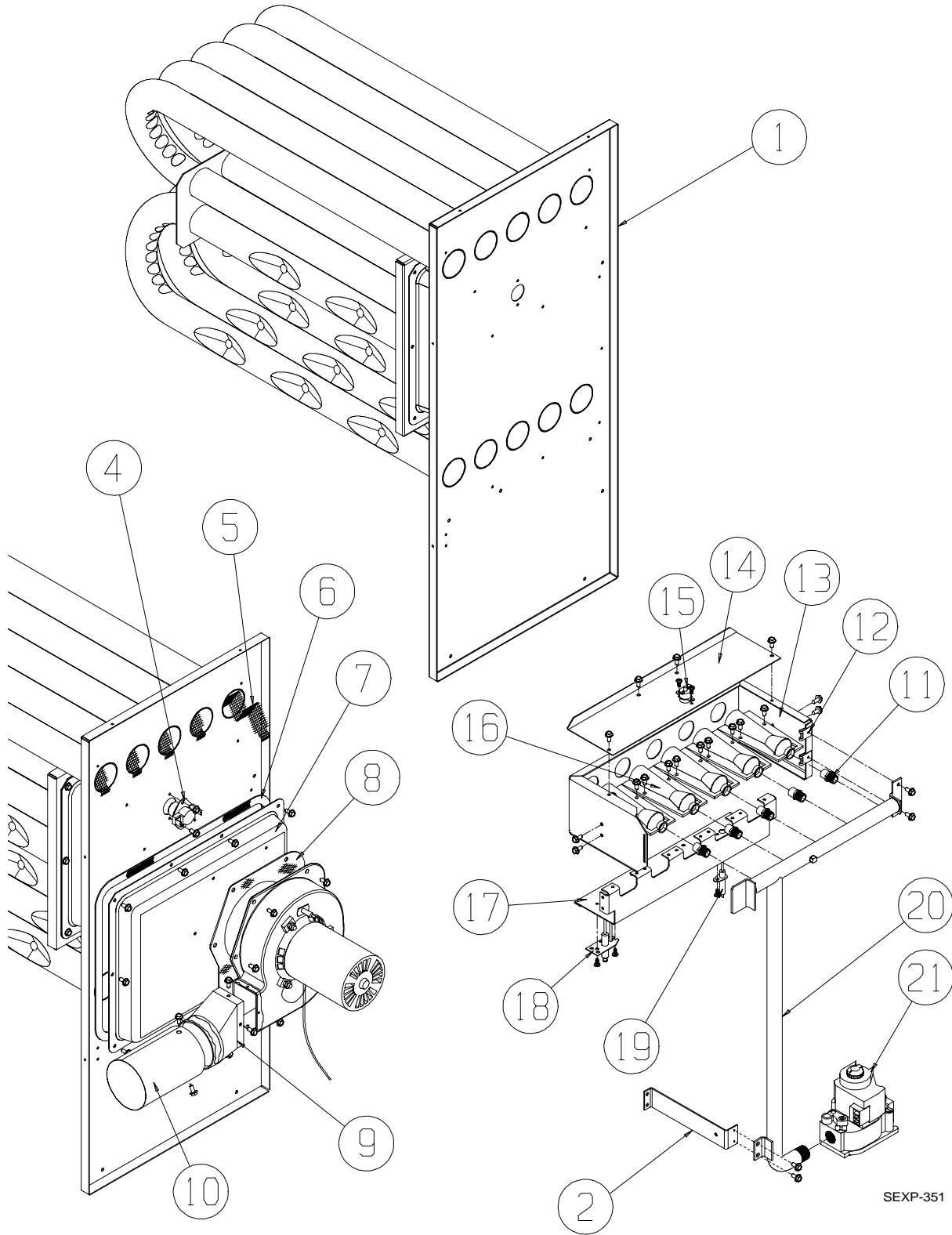

SEXP-351

This drawing to be used for reference for Pages 14, 15 and 16.

BURNER COMPONENTS

Dwg No.	Part No.	Description	WG421-*XB	WG421-*NB	WG421-*XC	WG421-*NC	WG421-*XD
1	S171-243	Heat Exchanger Assembly 75K	X	X			
1	S171-245	Heat Exchanger Assembly 100K			X	X	
1	S171-247	Heat Exchanger Assembly 125K					X
2	113-268	Manifold Bracket	X	X	X	X	X
4	8402-116	Limit Control L300-30	X	X	X	X	X
5	9010-083	NOx Screen		3		4	
6	1921-025-4600	46" Glas-Tak Tape	X	X	X	X	X
7	168-126	Collector Box	X	X			
7	168-127	Collector Box			X	X	
7	168-128	Collector Box					X
8	1921-044	Gasket Set	X	X	X	X	X
9	5809-013	3" Cast Inducer Transition	X	X	X	X	X
10	5809-017	3.031" x 4.625" Transition	X	X	X	X	X
11	9010-079	Orifice 2.40mm (.0960 dia.)	3	3	4	4	5
11	9010-082	Orifice 2.30mm (10% derate)	3	3	4	4	5
12	1012-314	U Clip Fastener	4	4	4	4	4
13	163-042	Burner Box	X	X			
13	163-044	Burner Box			X	X	
13	163-046	Burner Box					X
14	141-268	Flame Rollout Support	X	X			
14	141-269	Flame Rollout Support			X	X	
14	141-270	Flame Rollout Support					X
15	8402-124	Flame Rollout Switch L270	X	X	X	X	X
16	9010-078	In-Shot Burner 2.5 x 4.5	3	3	4	4	5
17	163-041	Burner Support	X	X			
17	163-043	Burner Support			X	X	
17	163-045	Burner Support					X
18	8554-024	DSI Spark Igniter	X	X	X	X	X
19	8554-025	Flame Sensor	X	X	X	X	X
20	5818-054	3-Hole Gas Manifold - 1/2"	X	X			
20	5818-055	4-Hole Gas Manifold - 1/2"			X	X	
20	5818-056	5-Hole Gas Manifold - 1/2"					X
21	5651-160	Natural Gas Valve 1/2 x 1/2	X	X	X	X	X

Refer to drawing on Page 13

BURNER COMPONENTS

Dwg No.	Part No.	Description	WG481-*XB	WG481-*NB	WG481-*XC	WG481-*NC	WG481-*XD
1	S171-243	Heat Exchanger Assembly 75K	X	X			
1	S171-245	Heat Exchanger Assembly 100K			X	X	
1	S171-247	Heat Exchanger Assembly 125K					X
2	113-268	Manifold Bracket	X	X	X	X	X
4	8402-116	Limit Control L300-30	X	X	X	X	X
5	9010-083	NOx Screen		3		4	
6	1921-025-4600	46" Glas-Tak Tape	X	X	X	X	X
7	168-126	Collector Box	X	X			
7	168-127	Collector Box			X	X	
7	168-128	Collector Box					X
8	1921-044	Gasket Set	X	X	X	X	X
9	5809-013	3" Cast Inducer Transition	X	X	X	X	X
10	5809-017	3.031" x 4.625" Transition	X	X	X	X	X
11	9010-079	Orifice 2.40mm (.0960 dia.)	3	3	4	4	5
11	9010-082	Orifice 2.30mm (10% derate)	3	3	4	4	5
12	1012-314	U Clip Fastener	4	4	4	4	4
13	163-042	Burner Box	X	X			
13	163-044	Burner Box			X	X	
13	163-046	Burner Box					X
14	141-268	Flame Rollout Support	X	X			
14	141-269	Flame Rollout Support			X	X	
14	141-270	Flame Rollout Support					X
15	8402-124	Flame Rollout Switch L270	X	X	X	X	X
16	9010-078	In-Shot Burner 2.5 x 4.5	3	3	4	4	5
17	163-041	Burner Support	X	X			
17	163-043	Burner Support			X	X	
17	163-045	Burner Support					X
18	8554-024	DSI Spark Igniter	X	X	X	X	X
19	8554-025	Flame Sensor	X	X	X	X	X
20	5818-054	3-Hole Gas Manifold - 1/2"	X	X			
20	5818-055	4-Hole Gas Manifold - 1/2"			X	X	
20	5818-056	5-Hole Gas Manifold - 1/2"					X
21	5651-160	Natural Gas Valve 1/2 x 1/2	X	X	X	X	X

Refer to drawing on Page 13

BURNER COMPONENTS

Dwg No.	Part No.	Description	WG601-*XB	WG601-*NB	WG601-*XC	WG601-*NC	WG601-*XD
1	S171-243	Heat Exchanger Assembly 75K	X	X			
1	S171-245	Heat Exchanger Assembly 100K			X	X	
1	S171-247	Heat Exchanger Assembly 125K					X
2	113-268	Manifold Bracket	X	X	X	X	X
4	8402-116	Limit Control L300-30	X	X	X	X	X
5	9010-083	NOx Screen		3		4	
6	1921-025-4600	46" Glas-Tak Tape	X	X	X	X	X
7	168-126	Collector Box	X	X			
7	168-127	Collector Box			X	X	
7	168-128	Collector Box					X
8	1921-044	Gasket Set	X	X	X	X	X
9	5809-013	3" Cast Inducer Transition	X	X	X	X	X
10	5809-017	3.031" x 4.625" Transition	X	X	X	X	X
11	9010-079	Orifice 2.40mm (.0960 dia.)	3	3	4	4	5
11	9010-082	Orifice 2.30mm (10% derate)	3	3	4	4	5
12	1012-314	U Clip Fastener	4	4	4	4	4
13	163-042	Burner Box	X	X			
13	163-044	Burner Box			X	X	
13	163-046	Burner Box					X
14	141-268	Flame Rollout Support	X	X			
14	141-269	Flame Rollout Support			X	X	
14	141-270	Flame Rollout Support					X
15	8402-124	Flame Rollout Switch L270	X	X	X	X	X
16	9010-078	In-Shot Burner 2.5 x 4.5	3	3	4	4	5
17	163-041	Burner Support	X	X			
17	163-043	Burner Support			X	X	
17	163-045	Burner Support					X
18	8554-024	DSI Spark Igniter	X	X	X	X	X
19	8554-025	Flame Sensor	X	X	X	X	X
20	5818-054	3-Hole Gas Manifold - 1/2"	X	X			
20	5818-055	4-Hole Gas Manifold - 1/2"			X	X	
20	5818-056	5-Hole Gas Manifold - 1/2"					X
21	5651-160	Natural Gas Valve 1/2 x 1/2	X	X	X	X	X

Refer to drawing on Page 13

CONTROL PANEL

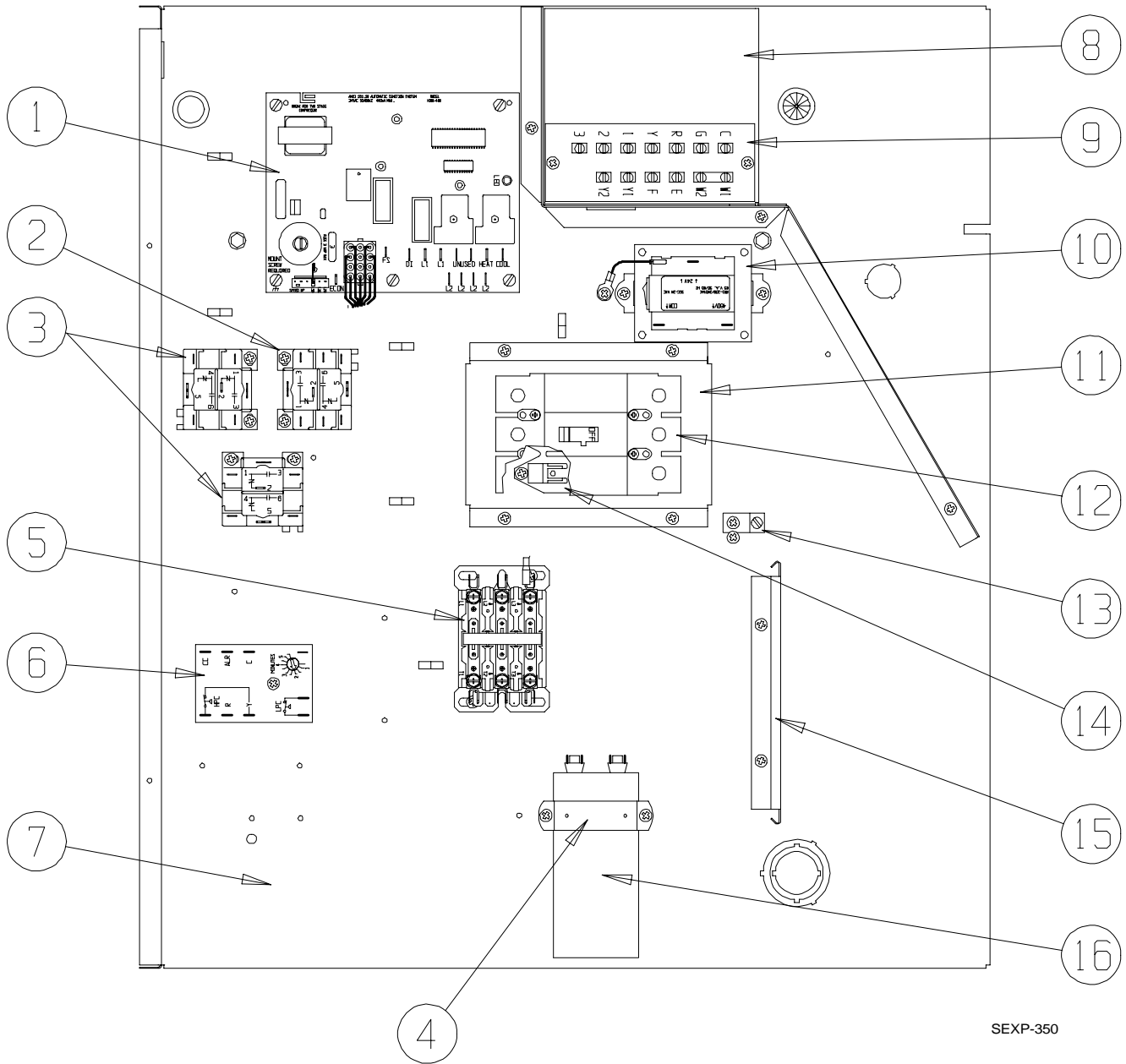

SEXP-350

CONTROL PANEL

Dwg No.	Part No.	Description	902-1092	902-1093	902-1094	902-1095	902-1096	902-1097	902-1098	902-1099	902-1100
1	5651-159	Integrated Furnace Control	X	X	X	X	X	X	X	X	X
2	8201-086	460 Volt Relay DPDT			X			X			X
3	8201-032	460 Volt Relay SPDT			2			2			2
4	8550-008	Capacitor Bracket	X			X			X		
4	8550-003	Capacitor Bracket		X	X		X	X		X	X
5	8401-025	Compressor Contactor, 2 Pole, 40A	X			X			X		
5	8401-002	Compressor Contactor, 3 Pole, 25A		X	X		X	X		X	X
6	8201-088	Compressor Control Module	X	X	X	X	X	X	X	X	X
7	517-233	Control Panel	X	X	X	X	X	X	X	X	X
8	117-234	Low Voltage Box	X	X	X	X	X	X	X	X	X
9	8607-024	Terminal Strip	X	X	X	X	X	X	X	X	X
10	8407-035	Transformer 55 VA	X	X		X	X		X	X	
10	8407-050	Transformer 65 VA			X			X			X
11	113-269	Circuit Breaker Mounting Base	X	X	X	X	X	X	X	X	X
12	8615-039	Circuit Breaker, 45A, 2-Pole	X								
12	8615-042	Circuit Breaker, 35A, 3-Pole		X			X				
12	8615-062	Circuit Breaker, 15A, 3-Pole			X						
12	8615-040	Circuit Breaker, 50A, 2-Pole				X		X			
12	8615-041	Circuit Breaker, 60A, 2-pole							X		
12	8615-044	Circuit Breaker, 45A, 3-Pole								X	
12	8615-063	Circuit Breaker, 20A, 3-pole									X
13	8611-006	Ground Terminal	X	X	X	X	X	X	X	X	X
14	8615-057	Circuit Breaker Mounting Feet	2	2		2	2		2	2	
14	8605-008	Circuit Breaker Mounting Feet			X			X			X
15	135-130	Wire Shield	X	X	X	X	X	X	X	X	X
16	8552-055	Capacitor 40+10 mfd 440 V	X			X					
16	8552-005	Capacitor 10 mfd 370 V		X	X		X	X		X	X
16	8552-058	Capacitor 80+10 mfd 440 V							X		
NS	4085-118	Wiring Diagram	X								
NS	4085-218	Wiring Diagram		X							
NS	4085-315	Wiring Diagram			X						
NS	4085-120	Wiring Diagram				X			X		
NS	4085-220	Wiring Diagram					X			X	
NS	4085-317	Wiring Diagram						X			X

NS – Not Shown

BLOWER ASSEMBLY

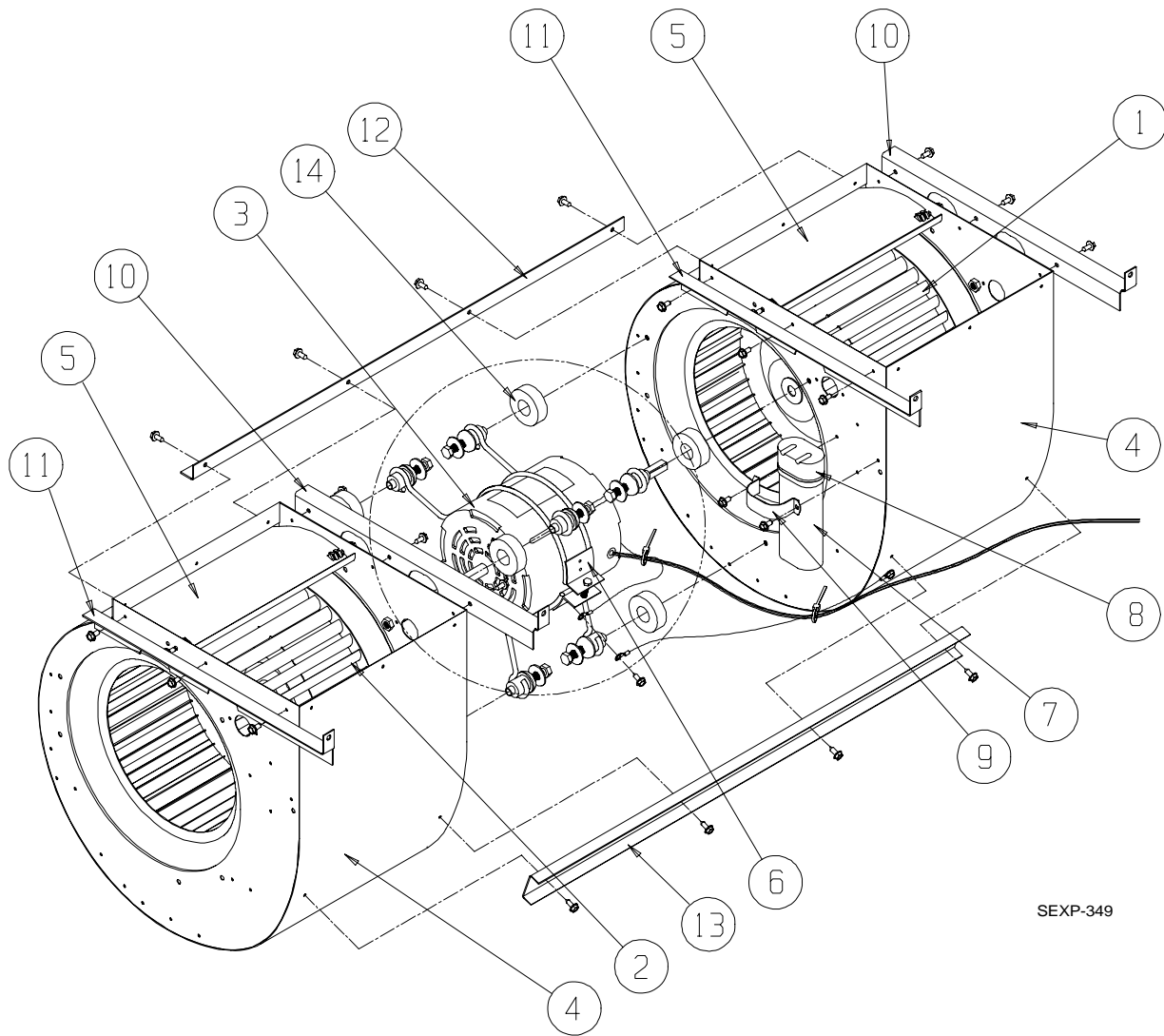

SEXP-349

Dwg. No.	Part No.	Description	900-249	900-251
1	5152-012	Blower Wheel 10-8	X	X
2	5152-011	Blower Wheel 10-8	X	X
3	8106-038	Motor 230/208 V	X	
3	8106-039	Motor 460 V		X
4	151-101	Blower Housing	2	2
5	144-166	Diffuser	2	2
6	8200-040	Motor Mount	X	X
7	8552-005	Capacitor 10 mfd 370V	X	X
8	8611-002	Capacitor Boot	X	X
9	8550-003	Capacitor Bracket	X	X
10	105X1075	Angle - Right	2	2
11	105Y1075	Angle - Left	2	2
12	105-881	Angle - Back	X	X
13	165-564	Channel - Front	X	X
14	5451-011	Grommets	3	3