

REPLACEMENT PARTS MANUAL

WALL MOUNTED GAS/ELECTRIC

MODELS:

WG423DA	WG423DB	WG424DC
WG482DA	WG482DB	WG483DC
WG602DA	WG602DB	WG603DC

General Notes

- Revised and/or additional pages may be issued from time to time.
- A complete and current manual consists of pages shown in the following contents section.

Important

- Contact the installing and/or local Bard distributor for all parts requirements. Make sure you have the complete model and serial number available from the unit rating plates.

Contents

<i>Description</i>	<i>Page</i>
Cabinet Components	
♦ Exploded View	2
♦ Usage List	3
♦ Usage List	4
♦ Usage List	5
♦ Usage List	6
♦ Usage List	7
♦ Usage List	8
♦ Blank Page	9
Functional Components	
♦ Exploded View	10
♦ Usage List	11
♦ Usage List	12
♦ Usage List	13
Burner Components	
♦ Exploded View	14
♦ Usage List	15
♦ Usage List	16
♦ Usage List	17
Control Panel	
♦ Layout	18
♦ Usage List	19
Blower Assembly	
♦ Exploded View	20
♦ Usage List	20



Bard Manufacturing Company, Inc.
Bryan, Ohio 43506
Since 1914...Moving ahead, just as planned.

Manual: 2110-804D
Supersedes: 2110-804C
File: Vol. III Tab 20
Date: 08-15-06

CABINET COMPONENTS

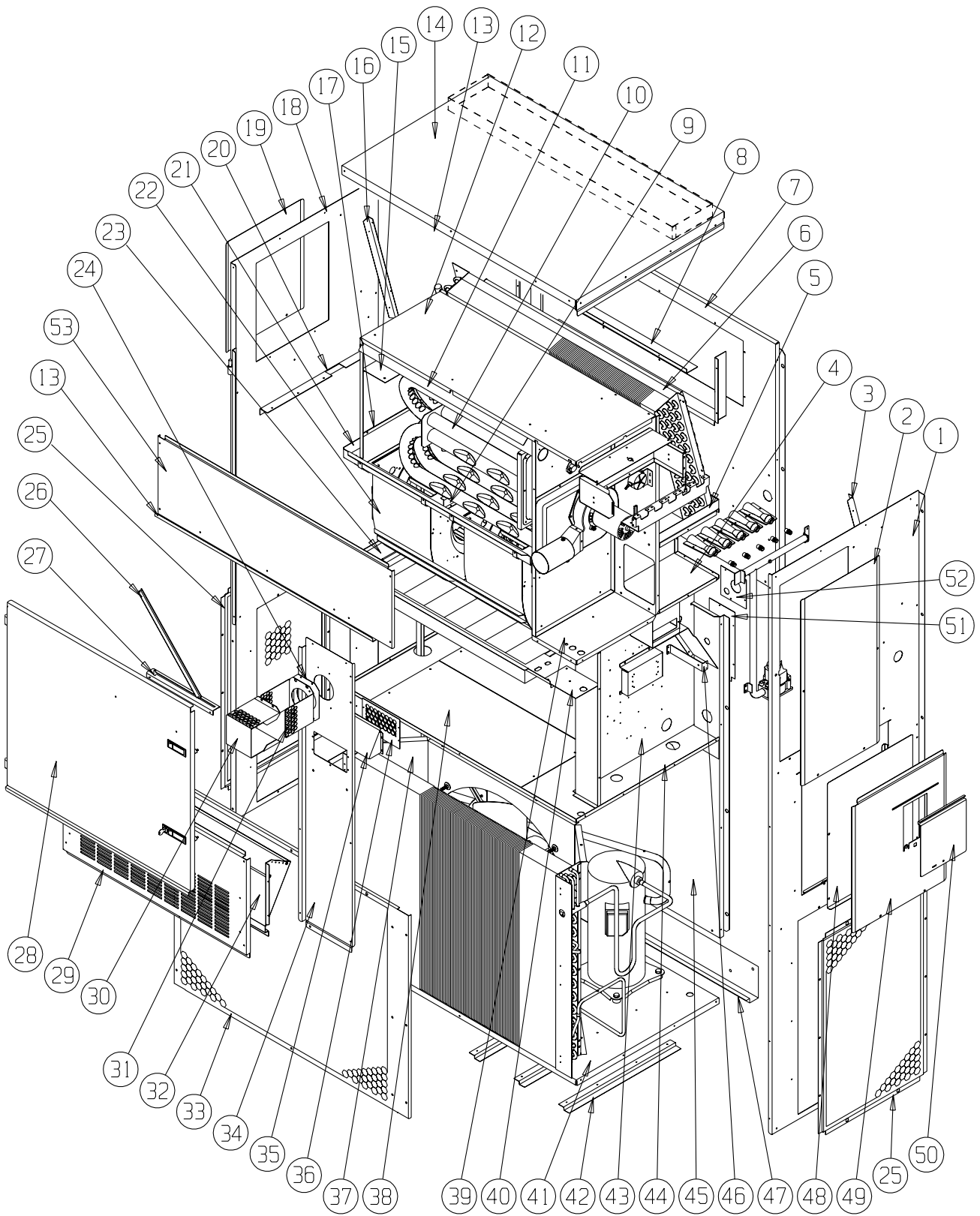

SEXP-459

This drawing to be used for reference for Pages 3, 4, 5, 6, 7 and 8.

CABINET COMPONENTS

Drawing No.	Part No.	Description	WG423DAXB	WG423DAXC	WG423DAXD	WG423DBXB	WG423DBXC	WG423DBXD	WG424DCXB	WG424DCXC	WG424DCXD
1	501-376-*	Right Side Assembly	X	X	X	X	X	X	X	X	X
2	S153-326-*	Vestibule Service Door	X	X	X	X	X	X	X	X	X
3	105X1073	Right Evaporator Support Angle	X	X	X	X	X	X	X	X	X
4	541-266	Right Drain Pan Support Assembly	X	X	X	X	X	X	X	X	X
5	S523-103	Drain Pan Assembly	X	X	X	X	X	X	X	X	X
6	105-1080	Evaporator Coil Fill Angle	X	X	X	X	X	X	X	X	X
7	509-156	Upper Back	X	X	X	X	X	X	X	X	X
8	111-063	Supply Air Frame	2	2	2	2	2	2	2	2	2
9	103-439	Heat Exchanger Support Offset	X	X	X	X	X	X	X	X	X
10	Heat Exch Assy	See Burner Components Diagram									
11	105-1076	Top Heat Exchanger Deflector	X	X	X	X	X	X	X	X	X
12	135-216	Inner Air Baffle	X	X	X	X	X	X	X	X	X
13	165-563-*	Top Rain Channel	X	X	X	X	X	X	X	X	X
14	507-246-*	Top Assembly	X	X	X	X	X	X	X	X	X
15	135-184	Right Heat Exchanger Deflector	X	X	X	X	X	X	X	X	X
16	105Y1073	Left Evaporator Support Angle	X	X	X	X	X	X	X	X	X
17	105-1066	Lower Heat Exchanger Deflector	X	X	X	X	X	X	X	X	X
18	501-445-*	Left Side Assembly	X	X	X	X	X	X	X	X	X
19	543-070-*	Left Access Cover	X	X	X	X	X	X	X	X	X
20	105-1070	Left Support Angle	X	X	X	X	X	X	X	X	X
21	S121-337	Blower Partition	X	X	X	X	X	X	X	X	X
22	S900-249	Complete Blower Assembly - 230V	X	X	X	X	X				
22	S900-277	Complete Blower Assembly - 460V						X	X	X	
23	131-134	Filter Tray	X	X	X	X	X	X	X	X	X
24	1921-051	Vent Terminal Gasket	X	X	X	X	X	X	X	X	X
25	118-057-*	Side Grille	2	2	2	2	2	2	2	2	2
26	105-1068	Door Stop Angle	X	X	X	X	X	X	X	X	X
Continued on Page 4											

* Exterior cabinet parts are manufactured with various paint color options. To insure that you receive the proper paint color, you must include the complete model and serial number of the unit for which cabinet parts are being ordered.

Refer to drawing on Page 2

CABINET COMPONENTS

Drawing No.	Part No.	Description	WG423DAXB	WG423DAXC	WG423DAXD	WG423DBXB	WG423DBXC	WG423DBXD	WG424DCXB	WG424DCXC	WG424DCXD
Continued from Page 3											
27	105-1069	Door Stop Slide	X	X	X	X	X	X	X	X	X
28	S553-389-*	Front Door Assembly	X	X	X	X	X	X	X	X	X
29	553-327-*	Vent Option Door Assembly	X	X	X	X	X	X	X	X	X
30	169-119	Outer Vent Hood	X	X	X	X	X	X	X	X	X
31	169-120	Inner Vent Hood	X	X	X	X	X	X	X	X	X
32	WGBFAD-5	Barometric Fresh Air Damper	X	X	X	X	X	X	X	X	X
33	118-048-*	Condenser Grille	X	X	X	X	X	X	X	X	X
34	549-098-*	Right Front Corner Assembly	X	X	X	X	X	X	X	X	X
35	S135-181-*	Air Intake Hood	X	X	X	X	X	X	X	X	X
36	S134-182-*	Air Intake Back	X	X	X	X	X	X	X	X	X
37	125-036	Fan Shroud	X	X	X	X	X	X	X	X	X
38	542-072	Condenser Partition Blank Off Plate	X	X	X	X	X	X	X	X	X
39	541-267	Heat Exchanger Support Assembly	X	X	X	X	X	X	X	X	X
40	142-071	Filter Blank Off Plate	X	X	X	X	X	X	X	X	X
41	127-302	Lower Base	X	X	X	X	X	X	X	X	X
42	103-438	Lower Base Offset	3	3	3	3	3	3	3	3	3
43	S902-1139	Control Panel Assembly	X	X	X						
43	S902-1140	Control Panel Assembly				X	X	X			
43	S902-1270	Control Panel Assembly							X	X	X
44	521-338	Condenser Partition Assembly	X	X	X	X	X	X	X	X	X
45	509-157	Lower Back Assembly	X	X	X	X	X	X	X	X	X
46	113-268	Manifold Bracket	X	X	X	X	X	X	X	X	X
47	113-140	Bottom Support Bracket	X	X	X	X	X	X	X	X	X
48	S133-163	Circuit Breaker Inner Door	X	X	X	X	X	X	X	X	X
49	S533-162-*	Control Panel Cover Assembly	X	X	X	X	X	X	X	X	X
50	S153-328-*	Disconnect Access Door	X	X	X	X	X	X	X	X	X
51	156-029	Conduit Entrance Plate	X	X	X	X	X	X	X	X	X
52	134-193	Conduit Access Panel	X	X	X	X	X	X	X	X	X
53	553-388-*	Upper Door Assembly	X	X	X	X	X	X	X	X	X

* Exterior cabinet parts are manufactured with various paint color options. To insure that you receive the proper paint color, you must include the complete model and serial number of the unit for which cabinet parts are being ordered.

Refer to drawing on Page 2

CABINET COMPONENTS

Drawing No.	Part No.	Description	WG482DAXB	WG482DAXC	WG482DAXD	WG482DBXB	WG482DBXC	WG482DBXD	WG483DCXB	WG483DCXC	WG483DCXD
1	501-376-*	Right Side Assembly	X	X	X	X	X	X	X	X	X
2	S153-326-*	Vestibule Service Door	X	X	X	X	X	X	X	X	X
3	105X1073	Right Evaporator Support Angle	X	X	X	X	X	X	X	X	X
4	541-266	Right Drain Pan Support Assembly	X	X	X	X	X	X	X	X	X
5	S523-103	Drain Pan Assembly	X	X	X	X	X	X	X	X	X
6	105-1080	Evaporator Coil Fill Angle	X	X	X	X	X	X	X	X	X
7	509-156	Upper Back	X	X	X	X	X	X	X	X	X
8	111-063	Supply Air Frame	2	2	2	2	2	2	2	2	2
9	103-439	Heat Exchanger Support Offset	X	X	X	X	X	X	X	X	X
10	Heat Exch Assy	See Burner Components Diagram									
11	105-1076	Top Heat Exchanger Deflector	X	X	X	X	X	X	X	X	X
12	135-216	Inner Air Baffle	X	X	X	X	X	X	X	X	X
13	165-563-*	Top Rain Channel	X	X	X	X	X	X	X	X	X
14	507-246-*	Top Assembly	X	X	X	X	X	X	X	X	X
15	135-184	Right Heat Exchanger Deflector	X	X	X	X	X	X	X	X	X
16	105Y1073	Left Evaporator Support Angle	X	X	X	X	X	X	X	X	X
17	105-1066	Lower Heat Exchanger Deflector	X	X	X	X	X	X	X	X	X
18	501-445-*	Left Side Assembly	X	X	X	X	X	X	X	X	X
19	543-070-*	Left Access Cover	X	X	X	X	X	X	X	X	X
20	105-1070	Left Support Angle	X	X	X	X	X	X	X	X	X
21	S121-337	Blower Partition	X	X	X	X	X	X	X	X	X
22	S900-249	Complete Blower Assembly - 230V	X	X	X	X	X				
22	S900-277	Complete Blower Assembly - 460V						X	X	X	
23	131-134	Filter Tray	X	X	X	X	X	X	X	X	X
24	1921-051	Vent Terminal Gasket	X	X	X	X	X	X	X	X	X
25	118-057-*	Side Grille	2	2	2	2	2	2	2	2	2
26	105-1068	Door Stop Angle	X	X	X	X	X	X	X	X	X
Continued on Page 6											

* Exterior cabinet parts are manufactured with various paint color options. To insure that you receive the proper paint color, you must include the complete model and serial number of the unit for which cabinet parts are being ordered.

Refer to drawing on Page 2

CABINET COMPONENTS

Drawing No.	Part No.	Description	WG482DAXB	WG482DAXC	WG482DAXD	WG482DBXB	WG482DBXC	WG482DBXD	WG483DCXB	WG483DCXC	WG483DCXD
Continued from Page 5											
27	105-1069	Door Stop Slide	X	X	X	X	X	X	X	X	X
28	S553-389-*	Front Door Assembly	X	X	X	X	X	X	X	X	X
29	553-327-*	Vent Option Door Assembly	X	X	X	X	X	X	X	X	X
30	169-119	Outer Vent Hood	X	X	X	X	X	X	X	X	X
31	169-120	Inner Vent Hood	X	X	X	X	X	X	X	X	X
32	WGBFAD-5	Barometric Fresh Air Damper	X	X	X	X	X	X	X	X	X
33	118-048-*	Condenser Grille	X	X	X	X	X	X	X	X	X
34	549-098-*	Right Front Corner Assembly	X	X	X	X	X	X	X	X	X
35	S135-181-*	Air Intake Hood	X	X	X	X	X	X	X	X	X
36	S134-182-*	Air Intake Back	X	X	X	X	X	X	X	X	X
37	125-036	Fan Shroud	X	X	X	X	X	X	X	X	X
38	542-072	Condenser Partition Blank Off Plate	2	2	2	2	2	2	2	2	2
39	541-267	Heat Exchanger Support Assembly	X	X	X	X	X	X	X	X	X
40	142-071	Filter Blank Off Plate	X	X	X	X	X	X	X	X	X
41	127-302	Lower Base	X	X	X	X	X	X	X	X	X
42	103-438	Lower Base Offset	3	3	3	3	3	3	3	3	3
43	S902-1109	Control Panel Assembly	X	X	X						
43	S902-1103	Control Panel Assembly				X	X	X			
43	S902-1271	Control Panel Assembly							X	X	X
44	521-338	Condenser Partition Assembly	X	X	X	X	X	X	X	X	X
45	509-157	Lower Back Assembly	X	X	X	X	X	X	X	X	X
46	113-268	Manifold Bracket	X	X	X	X	X	X	X	X	X
47	113-140	Bottom Support Bracket	X	X	X	X	X	X	X	X	X
48	S133-163	Circuit Breaker Inner Door	X	X	X	X	X	X	X	X	X
49	S533-162-*	Control Panel Cover Assembly	X	X	X	X	X	X	X	X	X
50	S153-328-*	Disconnect Access Door	X	X	X	X	X	X	X	X	X
51	134-193	Conduit Access Panel	X	X	X	X	X	X	X	X	X
52	156-029	Conduit Entrance Plate	X	X	X	X	X	X	X	X	X
53	553-388-*	Upper Door Assembly	X	X	X	X	X	X	X	X	X

* Exterior cabinet parts are manufactured with various paint color options. To insure that you receive the proper paint color, you must include the complete model and serial number of the unit for which cabinet parts are being ordered.

Refer to drawing on Page 2

CABINET COMPONENTS

Drawing No.	Part No.	Description	WG602DAXB	WG602DAXC	WG602DAXD	WG602DBXB	WG602DBXC	WG602DBXD	WG603DCXB	WG603DCXC	WG603DCXD
1	501-376-*	Right Side Assembly	X	X	X	X	X	X	X	X	X
2	S153-326-*	Vestibule Service Door	X	X	X	X	X	X	X	X	X
3	105X1073	Right Evaporator Support Angle	X	X	X	X	X	X	X	X	X
4	541-266	Right Drain Pan Support Assembly	X	X	X	X	X	X	X	X	X
5	S523-103	Drain Pan Assembly	X	X	X	X	X	X	X	X	X
6	105-1080	Evaporator Coil Fill Angle	X	X	X	X	X	X	X	X	X
7	509-156	Upper Back	X	X	X	X	X	X	X	X	X
8	111-063	Supply Air Frame	2	2	2	2	2	2	2	2	2
9	103-439	Heat Exchanger Support Offset	X	X	X	X	X	X	X	X	X
10	Heat Exch Assy	See Burner Components Diagram									
11	105-1076	Top Heat Exchanger Deflector	X	X	X	X	X	X	X	X	X
12	135-216	Inner Air Baffle	X	X	X	X	X	X	X	X	X
13	165-563-*	Top Rain Channel	X	X	X	X	X	X	X	X	X
14	507-246-*	Top Assembly	X	X	X	X	X	X	X	X	X
15	135-184	Right Heat Exchanger Deflector	X	X	X	X	X	X	X	X	X
16	105Y1073	Left Evaporator Support Angle	X	X	X	X	X	X	X	X	X
17	105-1066	Lower Heat Exchanger Deflector	X	X	X	X	X	X	X	X	X
18	501-445-*	Left Side Assembly	X	X	X	X	X	X	X	X	X
19	543-070-*	Left Access Cover	X	X	X	X	X	X	X	X	X
20	105-1070	Left Support Angle	X	X	X	X	X	X	X	X	X
21	S121-337	Blower Partition	X	X	X	X	X	X	X	X	X
22	S900-249	Complete Blower Assembly - 230V	X	X	X	X	X				
22	S900-277	Complete Blower Assembly - 460V						X	X	X	
23	131-134	Filter Tray	X	X	X	X	X	X	X	X	X
24	1921-051	Vent Terminal Gasket	X	X	X	X	X	X	X	X	X
25	118-057-*	Side Grille	2	2	2	2	2	2	2	2	2
26	105-1068	Door Stop Angle	X	X	X	X	X	X	X	X	X
Continued on Page 8											

* Exterior cabinet parts are manufactured with various paint color options. To insure that you receive the proper paint color, you must include the complete model and serial number of the unit for which cabinet parts are being ordered.

Refer to drawing on Page 2

CABINET COMPONENTS

Drawing No.	Part No.	Description	WG602DAXB	WG602DAXC	WG602DAXD	WG602DBXB	WG602DBXC	WG602DBXD	WG603DCXB	WG603DCXC	WG603DCXD
Continued from Page 7											
27	105-1069	Door Stop Slide	X	X	X	X	X	X	X	X	X
28	S553-389-*	Front Door Assembly	X	X	X	X	X	X	X	X	X
29	553-327-*	Vent Option Door Assembly	X	X	X	X	X	X	X	X	X
30	169-119	Outer Vent Hood	X	X	X	X	X	X	X	X	X
31	169-120	Inner Vent Hood	X	X	X	X	X	X	X	X	X
32	WGBFAD-5	Barometric Fresh Air Damper	X	X	X	X	X	X	X	X	X
33	118-048-*	Condenser Grille	X	X	X	X	X	X	X	X	X
34	549-098-*	Right Front Corner Assembly	X	X	X	X	X	X	X	X	X
35	S135-181-*	Air Intake Hood	X	X	X	X	X	X	X	X	X
36	S134-182-*	Air Intake Back	X	X	X	X	X	X	X	X	X
37	125-036	Fan Shroud	X	X	X	X	X	X	X	X	X
38	542-072	Condenser Partition Blank Off Plate	2	2	2	2	2	2	2	2	2
39	541-267	Heat Exchanger Support Assembly	X	X	X	X	X	X	X	X	X
40	142-071	Filter Blank Off Plate	X	X	X	X	X	X	X	X	X
41	127-302	Lower Base	X	X	X	X	X	X	X	X	X
42	103-438	Lower Base Offset	3	3	3	3	3	3	3	3	3
43	S902-1111	Control Panel Assembly	X	X	X						
43	S902-1112	Control Panel Assembly				X	X	X			
43	S902-1272	Control Panel Assembly							X	X	X
44	521-338	Condenser Partition Assembly	X	X	X	X	X	X	X	X	X
45	509-157	Lower Back Assembly	X	X	X	X	X	X	X	X	X
46	113-268	Manifold Bracket	X	X	X	X	X	X	X	X	X
47	113-140	Bottom Support Bracket	X	X	X	X	X	X	X	X	X
48	S133-163	Circuit Breaker Inner Door	X	X	X	X	X	X	X	X	X
49	S533-162-*	Control Panel Cover Assembly	X	X	X	X	X	X	X	X	X
50	S153-328-*	Disconnect Access Door	X	X	X	X	X	X	X	X	X
51	156-029	Conduit Entrance Plate	X	X	X	X	X	X	X	X	X
52	134-193	Conduit Access Panel	X	X	X	X	X	X	X	X	X
53	553-388-*	Upper Door Assembly	X	X	X	X	X	X	X	X	X

* Exterior cabinet parts are manufactured with various paint color options. To insure that you receive the proper paint color, you must include the complete model and serial number of the unit for which cabinet parts are being ordered.

Refer to drawing on Page 2

This page left blank intentionally

FUNCTIONAL COMPONENTS

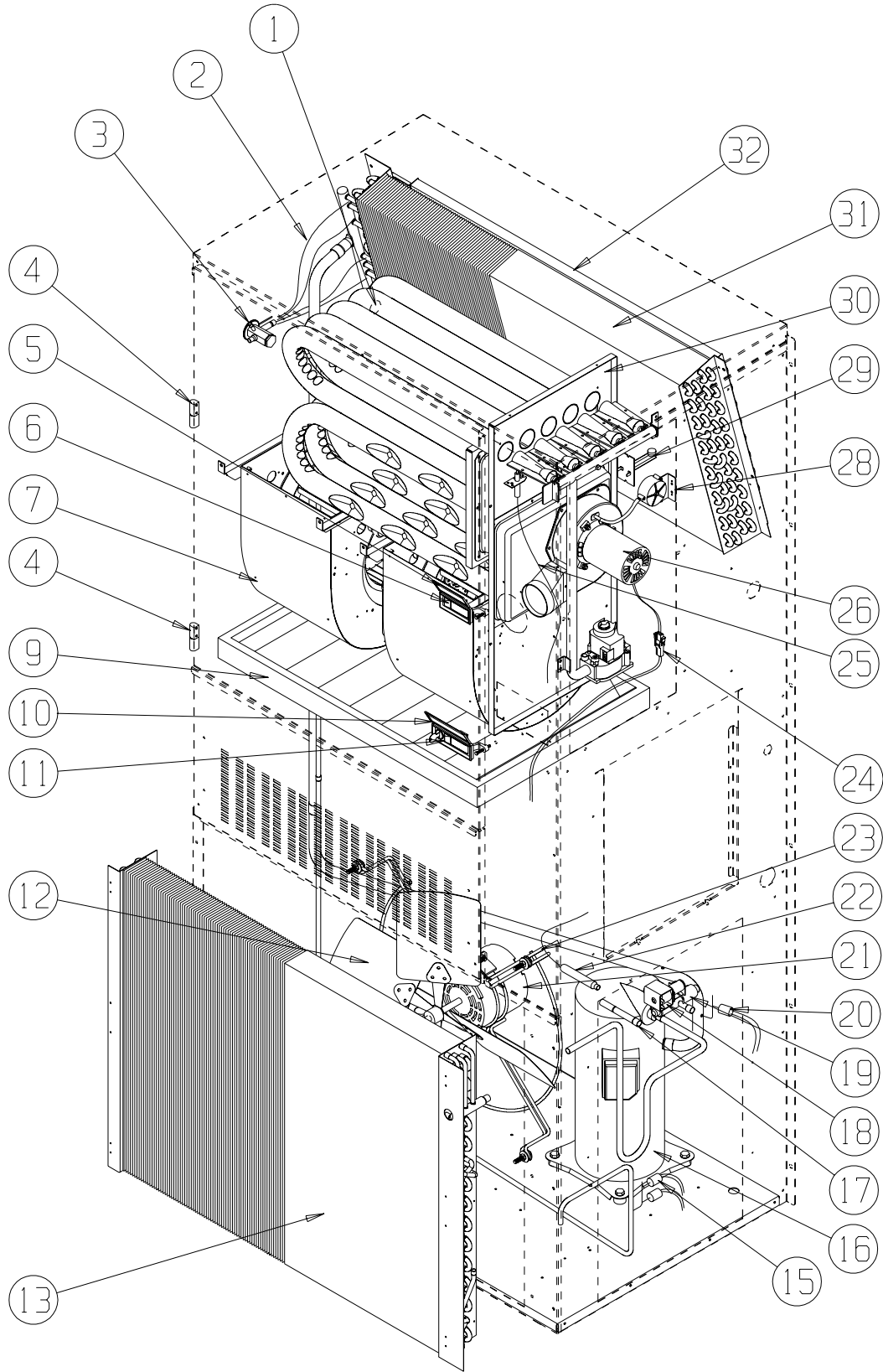

SEXP-461

This drawing to be used for reference for Pages 11, 12 and 13.

FUNCTIONAL COMPONENTS

Drawing No.	Part No.	Description	WG423DAXB	WG423DAXC	WG423DAXD	WG423DBXB	WG423DBXC	WG423DBXD	WG424DCXB	WG424DCXC	WG424DCXD
1	8408-038	Freeze Thermostat	X	X	X	X	X	X	X	X	X
2	5625-008	Distributor	X	X	X	X	X	X	X	X	X
3	5651-078	Expansion Valve	X	X	X	X	X	X	X	X	X
4	5400-005	Metal Lift-Off Hinge	2	2	2	2	2	2	2	2	2
5	1171-050	Weather Cover for Latch 1171-048	X	X	X	X	X	X	X	X	X
6	1171-048	Black Non-Lockable Latch	X	X	X	X	X	X	X	X	X
7	S900-249	Complete Blower Assembly 230/208	X	X	X	X	X				
7	S900-277	Complete Blower Assembly 460V							X	X	X
9	7004-027	20 x 30 x 2 Pleated Filter (Standard)	X	X	X	X	X	X	X	X	X
9	7003-030	20 x 30 x 1 AF Filter (Optional)	X	X	X	X	X	X	X	X	X
10	1171-051	Weather Cover for Latch 1171-049	X	X	X	X	X	X	X	X	X
11	1171-049	Black Lockable Latch	X	X	X	X	X	X	X	X	X
12	5151-054	Fan Blade	X	X	X	X	X	X	X	X	X
13	5051-078BX	Coil	X	X	X	X	X	X	X	X	X
15	1804-0106	High Pressure Switch (Flare)	X	X	X	X	X	X	X	X	X
16	8000-253	Compressor ZR42KC-PFV	X	X	X						
16	8000-205	Compressor ZR42K3-TF5				X	X	X			
16	8000-206	Compressor ZR42K3-TFD							X	X	X
17	5651-146	Check Valve	X	X	X	X	X	X	X	X	X
18	5650-037	Molded Plug	X	X	X	X	X	X	X	X	X
19	5650-045	Three Way Valve with Solenoid	X	X	X	X	X	X	X	X	X
20	1804-0107	Low Pressure Switch - Opt. - (Flare)	X	X	X	X	X	X	X	X	X
21	8105-039	Motor 230/208V	X	X	X	X	X				
21	8105-030	Motor 460V							X	X	X
22	800-0304	Capillary Tube Assembly	X	X	X	X	X	X	X	X	X
23	8200-004	Fan Motor Mount	X	X	X	X	X	X	X	X	X
24	3000-1121	Wire Assembly	X	X	X	X	X				
24	3000-1124	Wire Assembly							X	X	X
25	8600-011	Suppression Ignition Cable	X	X	X	X	X	X	X	X	X
26	8109-014	Induced Draft Blower 230V w/Transition	X	X	X	X	X				
26	8109-015	Induced Draft Blower 460V w/Transition							X	X	X
28	8406-103	.55" ± .05" Pressure Switch	X	X	X	X	X	X	X	X	X
29	8402-117	Limit Control L215-30 3"	X			X			X		
29	8402-123	Limit Control L180-30 3"		X			X			X	
29	8402-107	Limit Control L155-30 3"			X			X			X
30	Heat Exch.	See Burner Components Diagram	X	X	X	X	X	X	X	X	X
31	5060-106BX	Coil	X	X	X	X	X	X	X	X	X
32	5051-102BX	Reheat Coil	X	X	X	X	X	X	X	X	X

Opt = Optional

Refer to drawing on Page 10

FUNCTIONAL COMPONENTS

Drawing No.	Part No.	Description	WG482DAXB	WG482DAXC	WG482DAXD	WG482DBXB	WG482DBXC	WG482DBXD	WG483DCXB	WG483DCXC	WG483DCXD
1	8408-038	Freeze Thermostat	X	X	X	X	X	X	X	X	X
2	5625-008	Distributor	X	X	X	X	X	X	X	X	X
3	5651-161	Expansion Valve	X	X	X	X	X	X	X	X	X
4	5400-005	Metal Lift-Off Hinge	2	2	2	2	2	2	2	2	2
5	1171-050	Weather Cover for Latch 1171-048	X	X	X	X	X	X	X	X	X
6	1171-048	Black Non-Lockable Latch	X	X	X	X	X	X	X	X	X
7	S900-249	Complete Blower Assembly 230/208	X	X	X	X	X	X			
7	S900-277	Complete Blower Assembly 460V							X	X	X
9	7004-027	20 x 30 x 2 Pleated Filter (Standard)	X	X	X	X	X	X	X	X	X
9	7003-030	20 x 30 x 1 AF Filter (Optional)	X	X	X	X	X	X	X	X	X
10	1171-051	Weather Cover for Latch 1171-049	X	X	X	X	X	X	X	X	X
11	1171-049	Black Lockable Latch	X	X	X	X	X	X	X	X	X
12	5151-054	Fan Blade	X	X	X	X	X	X	X	X	X
13	5051-074BX	Coil	X	X	X	X	X	X	X	X	X
15	1804-0106	High Pressure Switch (Flare)	X	X	X	X	X	X	X	X	X
16	8000-236	Compressor ZR47KC-PFV	X	X	X						
16	8000-221	Compressor ZR47KC-TF5				X	X	X			
16	8000-222	Compressor ZR47KC-TFD							X	X	X
17	5651-146	Check Valve	X	X	X	X	X	X	X	X	X
18	5650-037	Molded Plug	X	X	X	X	X	X	X	X	X
19	5650-045	Three Way Valve with Solenoid	X	X	X	X	X	X	X	X	X
20	1804-0107	Low Pressure Switch - Opt. - (Flare)	X	X	X	X	X	X	X	X	X
21	8105-039	Motor 230/208V	X	X	X	X	X	X			
21	8105-030	Motor 460V							X	X	X
22	800-0304	Capillary Tube Assembly	X	X	X	X	X	X	X	X	X
23	8200-004	Fan Motor Mount	X	X	X	X	X	X	X	X	X
24	3000-1121	Wire Assembly	X	X	X	X	X	X			
24	3000-1124	Wire Assembly							X	X	X
25	8600-011	Suppression Ignition Cable	X	X	X	X	X	X	X	X	X
26	8109-014	Induced Draft Blower 230V w/Transition	X	X	X	X	X	X			
26	8109-015	Induced Draft Blower 460V w/Transition							X	X	X
28	8406-103	.55" ± .05" Pressure Switch	X	X	X	X	X	X	X	X	X
29	8402-117	Limit Control L215-30 3"	X			X			X		
29	8402-123	Limit Control L180-30 3"		X			X			X	
29	8402-107	Limit Control L155-30 3"			X			X			X
30	Heat Exch.	See Burner Components Diagram	X	X	X	X	X	X	X	X	X
31	5060-106BX	Coil	X	X	X	X	X	X	X	X	X
32	5051-102BX	Reheat Coil	X	X	X	X	X	X	X	X	X

Opt. = Optional

Refer to drawing on Page 10

FUNCTIONAL COMPONENTS

Drawing No.	Part No.	Description	WG602DAXB	WG602DAXC	WG602DAXD	WG602DBXB	WG602DBXC	WG602DBXD	WG603DCXB	WG603DCXC	WG603DCXD
1	8408-038	Freeze Thermostat	X	X	X	X	X	X	X	X	X
2	5625-036	Distributor	X	X	X	X	X	X	X	X	X
3	5651-131	Expansion Valve	X	X	X	X	X	X	X	X	X
4	5400-005	Metal Lift-Off Hinge	2	2	2	2	2	2	2	2	2
5	1171-050	Weather Cover for Latch 1171-048	X	X	X	X	X	X	X	X	X
6	1171-048	Black Non-Lockable Latch	X	X	X	X	X	X	X	X	X
7	S900-249	Complete Blower Assembly 230/208	X	X	X	X	X	X			
7	S900-277	Complete Blower Assembly 460V							X	X	X
9	7004-027	20 x 30 x 2 Pleated Filter (Standard)	X	X	X	X	X	X	X	X	X
9	7003-030	20 x 30 x 1 AF Filter (Optional)	X	X	X	X	X	X	X	X	X
10	1171-051	Weather Cover for Latch 1171-049	X	X	X	X	X	X	X	X	X
11	1171-049	Black Lockable Latch	X	X	X	X	X	X	X	X	X
12	5151-054	Fan Blade	X	X	X	X	X	X	X	X	X
13	5051-074BX	Coil	X	X	X	X	X	X	X	X	X
15	1804-0106	High Pressure Switch (Flare)	X	X	X	X	X	X	X	X	X
16	8000-153	Compressor ZR61K3-PFV	X	X	X						
16	8000-154	Compressor ZR61K3-TF5				X	X	X			
16	8000-155	Compressor ZR61K3-TFD							X	X	X
17	5651-146	Check Valve	X	X	X	X	X	X	X	X	X
18	5650-037	Molded Plug	X	X	X	X	X	X	X	X	X
19	5650-045	Three Way Valve with Solenoid	X	X	X	X	X	X	X	X	X
20	1804-0107	Low Pressure Switch - Opt. - (Flare)	X	X	X	X	X	X	X	X	X
21	8105-039	Motor 230/208V	X	X	X	X	X	X			
21	8105-030	Motor 460V							X	X	X
22	800-0304	Capillary Tube Assembly	X	X	X	X	X	X	X	X	X
23	8200-004	Fan Motor Mount	X	X	X	X	X	X	X	X	X
24	3000-1121	Wire Assembly	X	X	X	X	X	X			
24	3000-1124	Wire Assembly							X	X	X
25	8600-011	Suppression Ignition Cable	X	X	X	X	X	X	X	X	X
26	8109-014	Induced Draft Blower 230V w/Transition	X	X	X	X	X	X			
26	8109-015	Induced Draft Blower 460V w/Transition							X	X	X
28	8406-103	.55" ± .05" Pressure Switch	X	X	X	X	X	X	X	X	X
29	8402-117	Limit Control L215-30 3"	X			X			X		
29	8402-123	Limit Control L180-30 3"		X			X			X	
29	8402-107	Limit Control L155-30 3"			X			X			X
30	Heat Exch.	See Burner Components Diagram	X	X	X	X	X	X	X	X	X
31	5060-105BX	Coil	X	X	X	X	X	X	X	X	X
32	5051-102BX	Reheat Coil	X	X	X	X	X	X	X	X	X

Opt. = Optional

Refer to drawing on Page 10

BURNER COMPONENTS

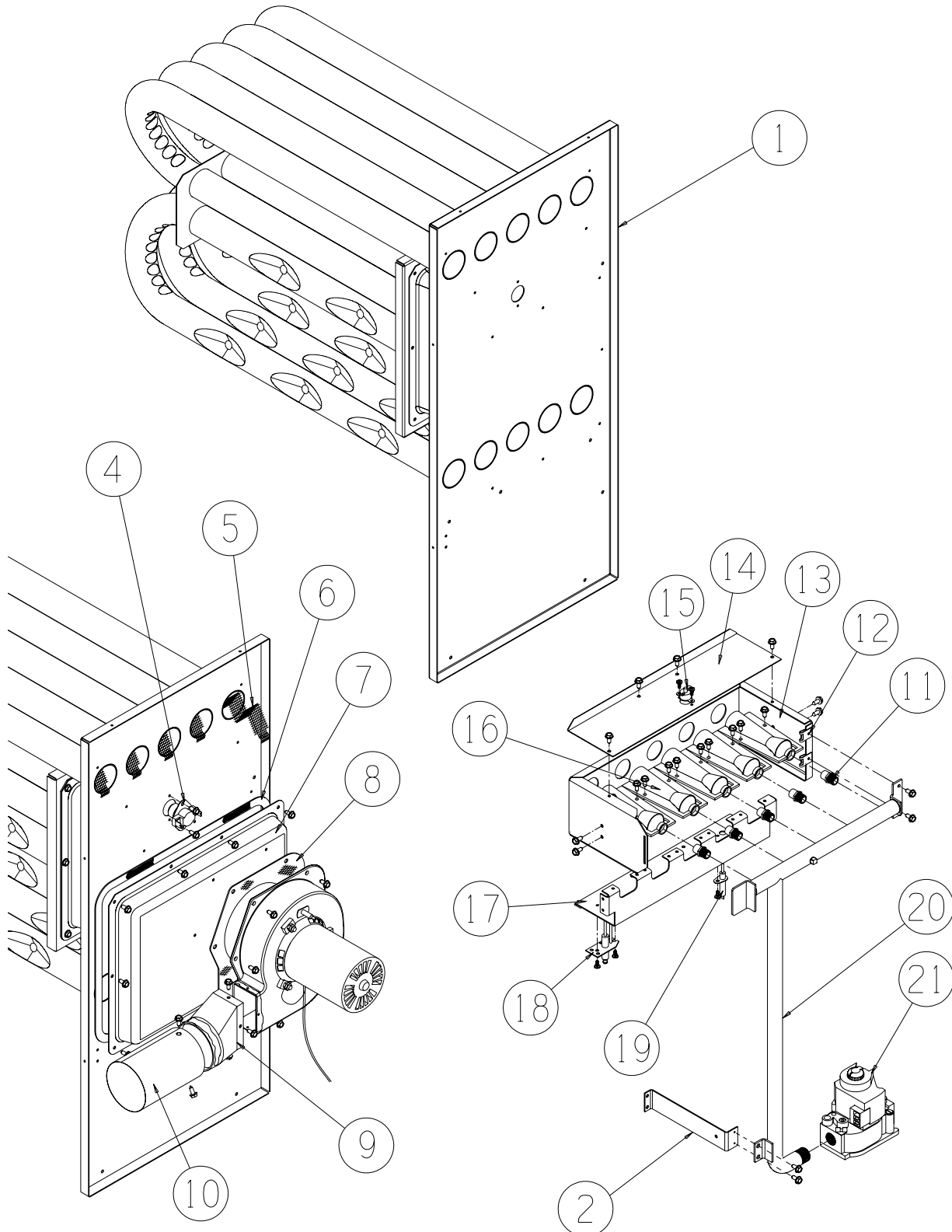

SEXP-351

This drawing to be used for reference for Pages 15, 16 and 17.

BURNER COMPONENTS

Drawing No.	Part No.	Description	WG423/424D*XB	WG423/424D*NB	WG423/424D*XC	WG423/424D*NC	WG423/424D*XD	WG423/424D*ND
1	S171-243	Heat Exchanger Assembly 75K	X	X				
1	S171-245	Heat Exchanger Assembly 100K			X	X		
1	S171-247	Heat Exchanger Assembly 125K					X	X
2	113-268	Manifold Bracket	X	X	X	X	X	X
4	8402-116	Limit Control L300-30	X	X	X	X	X	X
5	9010-083	NOx Screen		3		4		5
6	1921-025-4600	46" Glas-Tak Tape	X	X	X	X	X	X
7	168-126	Collector Box	X	X				
7	168-127	Collector Box			X	X		
7	168-128	Collector Box					X	X
8	1921-044	Gasket Set	X	X	X	X	X	X
9	5809-013	3" Cast Inducer Transition	X	X	X	X	X	X
10	5809-017	3.031" x 4.625" Transition	X	X	X	X	X	X
11	9010-079	Orifice 2.40mm (.0960 diameter)	3	3	4	4	5	5
11	9010-082	Orifice 2.30mm (10% derate)	3	3	4	4	5	5
12	1012-314	U Clip Fastener	4	4	4	4	4	4
13	163-042	Burner Box	X	X				
13	163-044	Burner Box			X	X		
13	163-046	Burner Box					X	X
14	141-268	Flame Rollout Support	X	X				
14	141-269	Flame Rollout Support			X	X		
14	141-270	Flame Rollout Support					X	X
15	8402-124	Flame Rollout Switch L270	X	X	X	X	X	X
16	9010-078	In-Shot Burner 2.5 x 4.5	3	3	4	4	5	5
17	163-041	Burner Support	X	X				
17	163-043	Burner Support			X	X		
17	163-045	Burner Support					X	X
18	8554-024	DSI Spark Igniter	X	X	X	X	X	X
19	8554-025	Flame Sensor	X	X	X	X	X	X
20	5818-054	3-Hole Gas Manifold - 1/2"	X	X				
20	5818-055	4-Hole Gas Manifold - 1/2"			X	X		
20	5818-056	5-Hole Gas Manifold - 1/2"					X	X
21	5651-160	Natural Gas Valve 1/2 x 1/2	X	X	X	X	X	X

Refer to drawing on Page 14

BURNER COMPONENTS

Drawing No.	Part No.	Description	WG482/483D*XB	WG482/483D*NB	WG482/483D*XC	WG482/483D*NC	WG482/483D*XD	WG482/483D*ND
1	S171-243	Heat Exchanger Assembly 75K	X	X				
1	S171-245	Heat Exchanger Assembly 100K			X	X		
1	S171-247	Heat Exchanger Assembly 125K					X	X
2	113-268	Manifold Bracket	X	X	X	X	X	X
4	8402-116	Limit Control L300-30	X	X	X	X	X	X
5	9010-083	NOx Screen		3		4		5
6	1921-025-4600	46" Glas-Tak Tape	X	X	X	X	X	X
7	168-126	Collector Box	X	X				
7	168-127	Collector Box			X	X		
7	168-128	Collector Box					X	X
8	1921-044	Gasket Set	X	X	X	X	X	X
9	5809-013	3" Cast Inducer Transition	X	X	X	X	X	X
10	5809-017	3.031" x 4.625" Transition	X	X	X	X	X	X
11	9010-079	Orifice 2.40mm (.0960 diameter)	3	3	4	4	5	5
11	9010-082	Orifice 2.30mm (10% derate)	3	3	4	4	5	5
12	1012-314	U Clip Fastener	4	4	4	4	4	4
13	163-042	Burner Box	X	X				
13	163-044	Burner Box			X	X		
13	163-046	Burner Box					X	X
14	141-268	Flame Rollout Support	X	X				
14	141-269	Flame Rollout Support			X	X		
14	141-270	Flame Rollout Support					X	X
15	8402-124	Flame Rollout Switch L270	X	X	X	X	X	X
16	9010-078	In-Shot Burner 2.5 x 4.5	3	3	4	4	5	5
17	163-041	Burner Support	X	X				
17	163-043	Burner Support			X	X		
17	163-045	Burner Support					X	X
18	8554-024	DSI Spark Igniter	X	X	X	X	X	X
19	8554-025	Flame Sensor	X	X	X	X	X	X
20	5818-054	3-Hole Gas Manifold - 1/2"	X	X				
20	5818-055	4-Hole Gas Manifold - 1/2"			X	X		
20	5818-056	5-Hole Gas Manifold - 1/2"					X	X
21	5651-160	Natural Gas Valve 1/2 x 1/2	X	X	X	X	X	X

Refer to drawing on Page 14

BURNER COMPONENTS

Drawing No.	Part No.	Description	WG602/603D*XB	WG602/603D*NB	WG602/603D*XC	WG602/603D*NC	WG602/603D*XD	WG602/603D*ND
1	S171-243	Heat Exchanger Assembly 75K	X	X				
1	S171-245	Heat Exchanger Assembly 100K			X	X		
1	S171-247	Heat Exchanger Assembly 125K					X	X
2	113-268	Manifold Bracket	X	X	X	X	X	X
4	8402-116	Limit Control L300-30	X	X	X	X	X	X
5	9010-083	NOx Screen		3		4		5
6	1921-025-4600	46" Glas-Tak Tape	X	X	X	X	X	X
7	168-126	Collector Box	X	X				
7	168-127	Collector Box			X	X		
7	168-128	Collector Box					X	X
8	1921-044	Gasket Set	X	X	X	X	X	X
9	5809-013	3" Cast Inducer Transition	X	X	X	X	X	X
10	5809-017	3.031" x 4.625" Transition	X	X	X	X	X	X
11	9010-079	Orifice 2.40mm (.0960 diameter)	3	3	4	4	5	5
11	9010-082	Orifice 2.30mm (10% derate)	3	3	4	4	5	5
12	1012-314	U Clip Fastener	4	4	4	4	4	4
13	163-042	Burner Box	X	X				
13	163-044	Burner Box			X	X		
13	163-046	Burner Box					X	X
14	141-268	Flame Rollout Support	X	X				
14	141-269	Flame Rollout Support			X	X		
14	141-270	Flame Rollout Support					X	X
15	8402-124	Flame Rollout Switch L270	X	X	X	X	X	X
16	9010-078	In-Shot Burner 2.5 x 4.5	3	3	4	4	5	5
17	163-041	Burner Support	X	X				
17	163-043	Burner Support			X	X		
17	163-045	Burner Support					X	X
18	8554-024	DSI Spark Igniter	X	X	X	X	X	X
19	8554-025	Flame Sensor	X	X	X	X	X	X
20	5818-054	3-Hole Gas Manifold - 1/2"	X	X				
20	5818-055	4-Hole Gas Manifold - 1/2"			X	X		
20	5818-056	5-Hole Gas Manifold - 1/2"					X	X
21	5651-160	Natural Gas Valve 1/2 x 1/2	X	X	X	X	X	X

Refer to drawing on Page 14

CONTROL PANEL

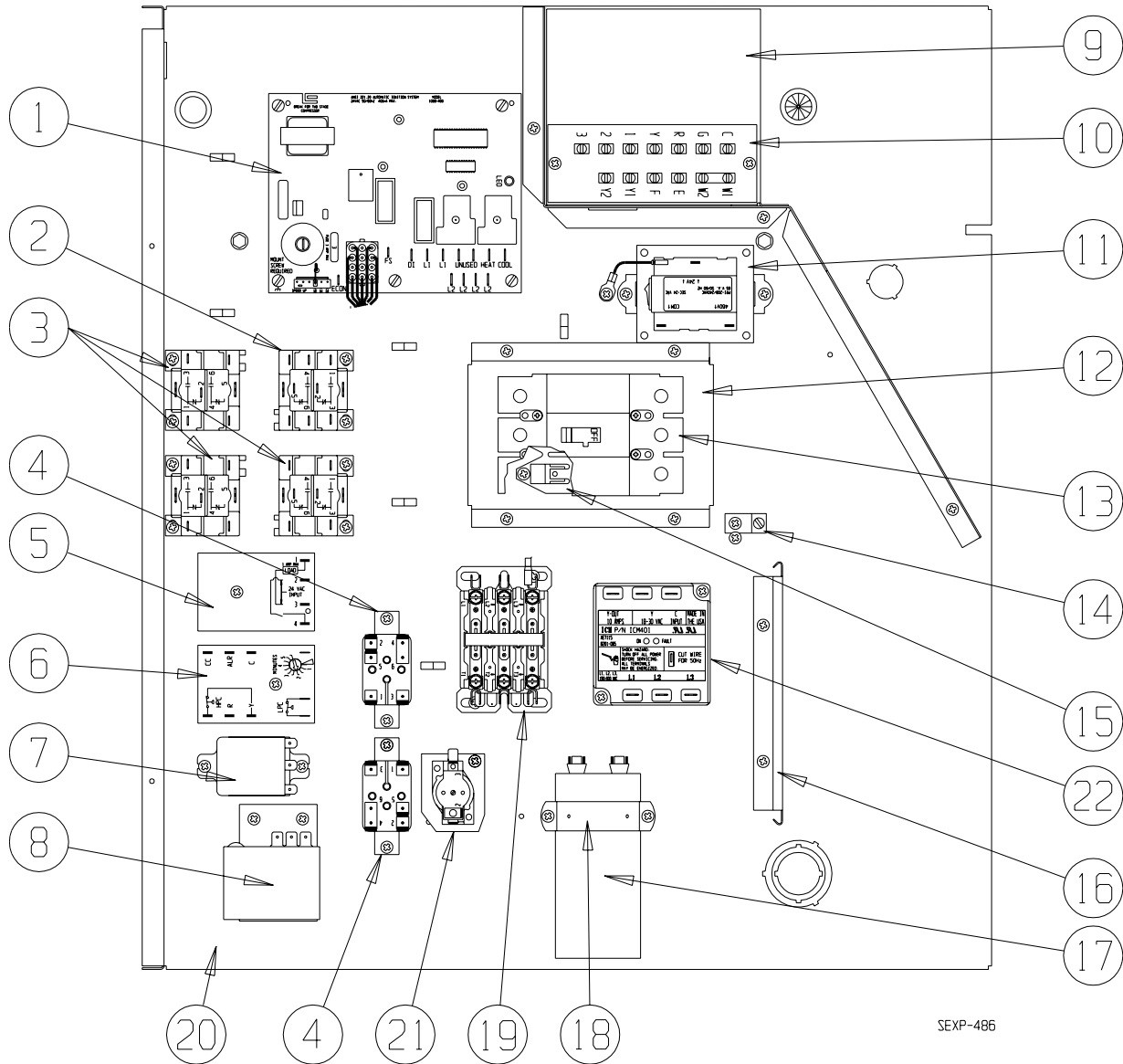

SEXP-486

CABINET COMPONENTS

Drawing No.	Part No.	Description	WG423DA	WG423DB	WG424DC	WG482DA	WG482DB	WG483DC	WG602DA	WG602DB	WG603DC
1	5651-159	Integrated Furnace Control	X	X	X	X	X	X	X	X	X
2	8201-086	460 Volt Relay DPDT			X			X			X
3	8201-032	460 Volt Relay SPDT			3			3			3
4	8201-062	Control Relay	2	2	2	2	2	2	2	2	2
5	8201-089	Time Delay Relay #1	X	X	X	X	X	X	X	X	X
6	8201-088	Compressor Control Module	X	X	X	X	X	X	X	X	X
7	8201-071	Control Relay #1	X	X	X	X	X	X	X	X	X
8	8408-037	Return Air Thermostat	X	X	X	X	X	X	X	X	X
9	117-248	Low Voltage Box	X	X	X	X	X	X	X	X	X
10	8607-024	Terminal Strip	X	X	X	X	X	X	X	X	X
11	8407-048	Transformer 65 VA 208/240-24V	X	X		X	X		X	X	
11	8407-050	Transformer 65VA 480-24V			X			X			X
12	113-269	Circuit Breaker Mounting Base	X	X	X	X	X	X	X	X	X
13	8615-042	Circuit Breaker, 35A, 3 Pole, 240V		X			X				
13	8615-062	Circuit Breaker, 15A, 3 Pole, 480V			X						
13	8615-040	Circuit Breaker, 50A, 2 Pole, 240V	X			X					
13	8615-041	Circuit Breaker, 60A, 2 Pole, 240V							X		
13	8615-044	Circuit Breaker, 45A, 3 Pole, 240V								X	
13	8615-063	Circuit Breaker, 20A, 3 Pole, 480V									X
14	8611-006	Ground Terminal	X	X	X	X	X	X	X	X	X
15	8615-057	Circuit Breaker Mounting Feet	2	2		2	2		2	2	
15	8615-008	Circuit Breaker Mounting Feet			.5			.5			.5
16	135-130	Wire Shield	X	X	X	X	X	X	X	X	X
17	8552-055	Capacitor 40+10 MFD 440V	X			X					
17	8552-005	Capacitor 10 MFD 370V		X	X		X	X		X	X
17	8552-058	Capacitor 80+10 MFD 440V							X		
18	8550-008	Capacitor Bracket	X			X			X		
18	8550-003	Capacitor Bracket		X	X		X	X		X	X
19	8401-025	Compressor Contactor, 2 Pole, 40A	X			X			X		
19	8401-002	Compressor Contactor, 3 Pole, 25A		X	X		X	X		X	X
20	517-233	Control Panel	X	X	X	X	X	X	X	X	X
21	8201-045	Time Delay Relay #2	X	X	X	X	X	X	X	X	X
22	8201-085	3 Phase Line Monitor		X	X		X	X		X	X
NS	4085A128	Wiring Diagram	X								
NS	4085A228	Wiring Diagram		X							
NS	4085A356	Wiring Diagram			X						
NS	4085A124	Wiring Diagram				X			X		
NS	4085A222	Wiring Diagram					X			X	
NS	4085A358	Wiring Diagram						X			X

NS – Not Shown

BLOWER ASSEMBLY

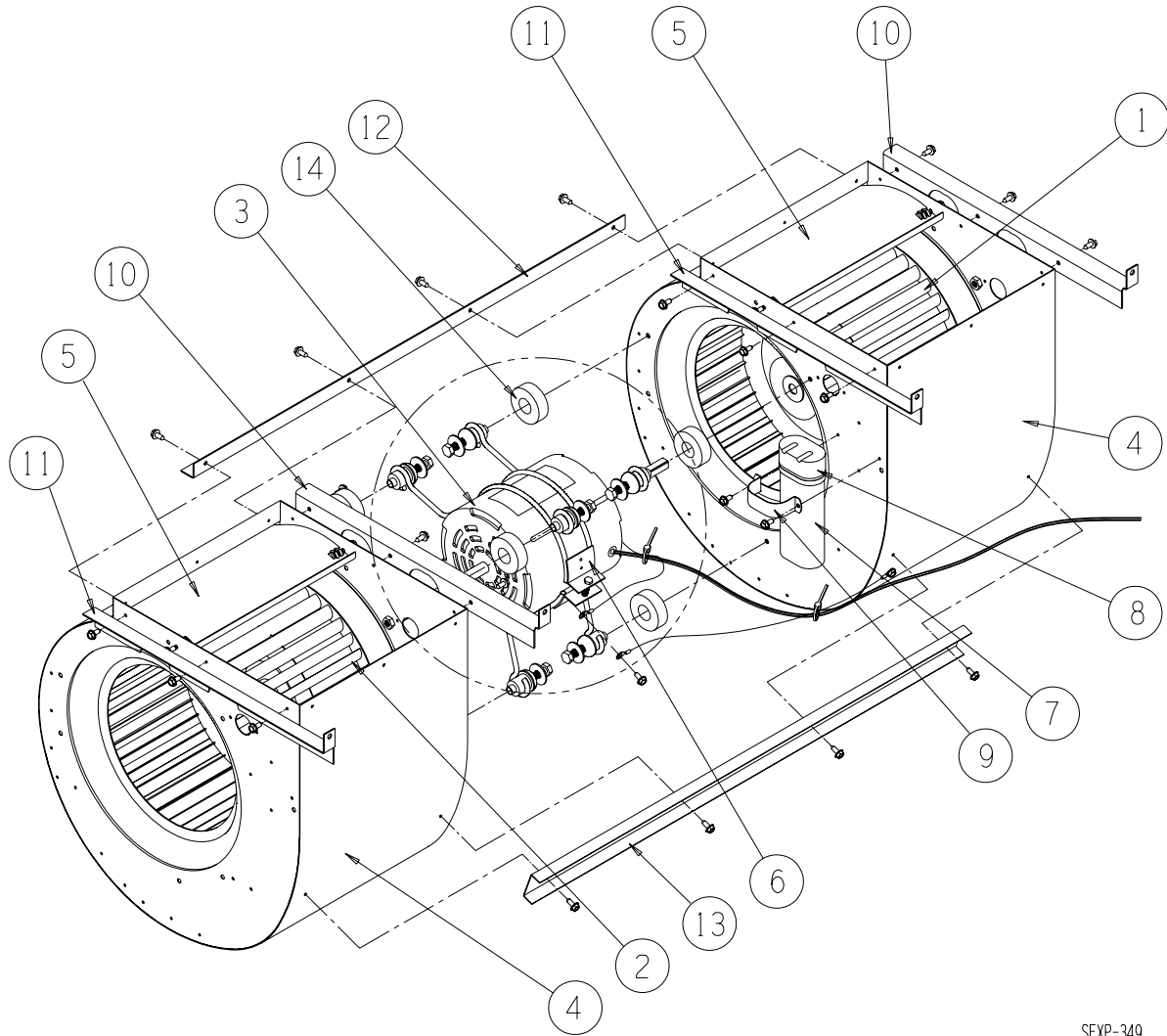

SEXP-349

Drawing No.	Part No.	Description	S900-249	S900-277
1	5152-011	Blower Wheel 10-8	X	X
2	5152-012	Blower Wheel 10-8	X	X
3	8106-038	Motor 230/208 V	X	
3	8106-043	Motor 460V		X
4	151-101	Blower Housing	2	2
5	144-166	Diffuser	2	2
6	8200-040	Motor Mount	X	X
7	8552-005	Capacitor 10 MFD 370V	X	X
8	8611-002	Capacitor Boot	X	X
9	8550-003	Capacitor Bracket	X	X
10	105X1075	Angle – Right	2	2
11	105Y1075	Angle – Left	2	2
12	105-881	Angle – Back	X	X
13	165-564	Channel – Front	X	X
14	5451-011	Grommets	3	3