REPLACEMENT PARTS MANUAL

WALL MOUNTED GAS/ELECTRIC

Models:

WG3S2-A WG3S2CA WG3S2-B WG3S2CB WG3S2-C WG3S2CC
WG4S2-A WG4S2CA WG4S2-B WG4S2CB WG4S2-C WG4S2CC
WG5S2-A WG5S2CA WG5S2-B WG5S2CB WG5S2-C WG5S2CC

General Notes

- Revised and/or additional pages may be issued from time to time.
- A complete and current manual consists of pages shown in the following contents section.

Important

- Contact the installing and/or local Bard distributor for all parts requirements. Make sure to have the complete model and serial number available from the unit rating plates.



Contents

<i>Description</i>	<i>Page</i>
Cabinet Components	
♦ Exploded View	2
♦ Usage List	3
♦ Usage List	4
Functional Components	
♦ Exploded View	6
♦ Usage List	7
Burner Components	
♦ Exploded View	8
♦ Usage List	9
♦ Usage List	10
♦ Usage List	11
Control Panel	
♦ Exploded View	12
♦ Usage List	13
Blower Assembly	
♦ Exploded View	14
♦ Usage List	14



Bard Manufacturing Company, Inc.
Bryan, Ohio 43506
www.bardhvac.com

Manual: 2110-812G
Supersedes: 2110-812F
Date: 6-10-15

CABINET COMPONENTS

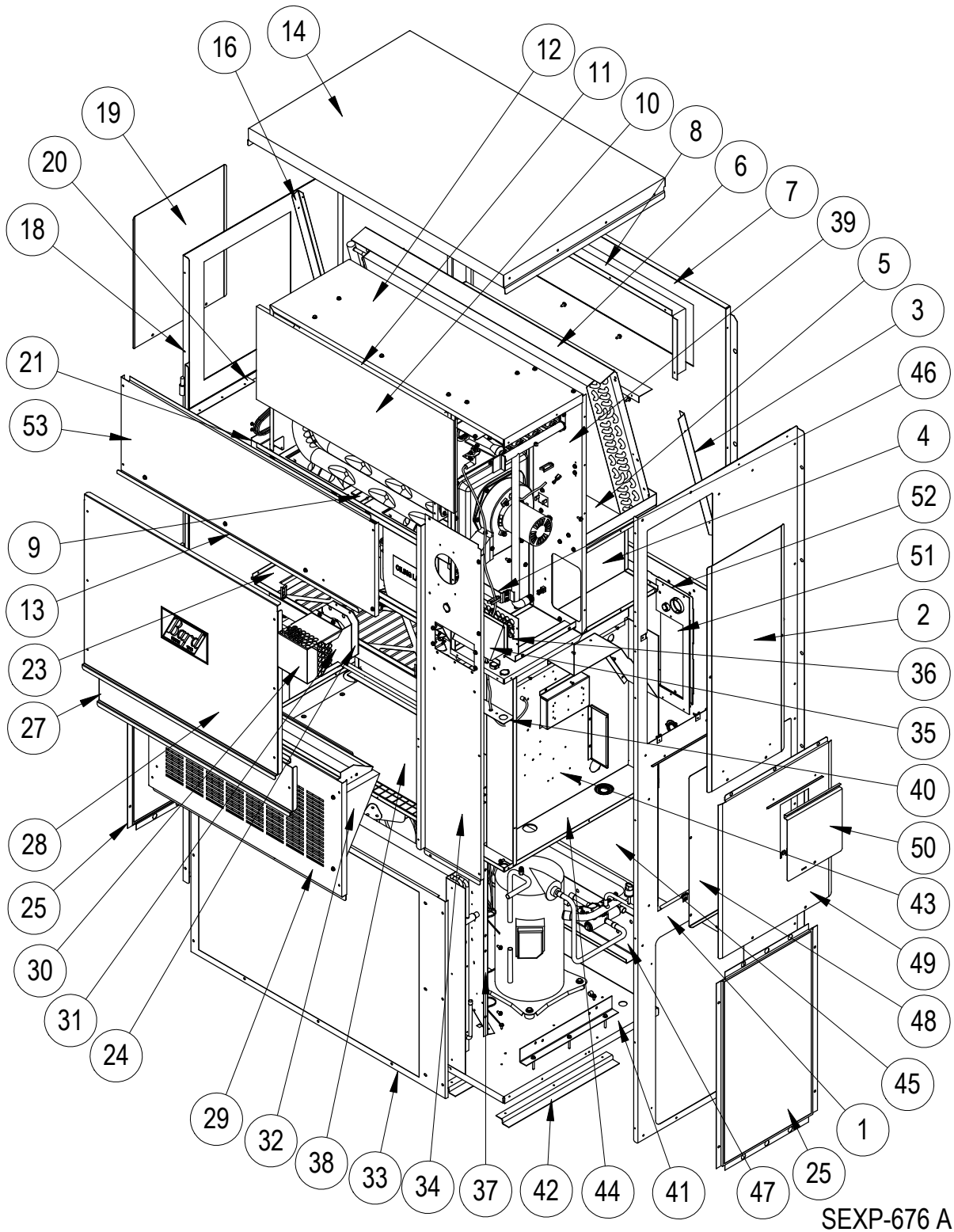

This drawing to be used as reference for pages 3 and 4

CABINET COMPONENTS

Drawing No.	Part No.	Description	WG3S2	WG4S2	WG5S2
1	S501-570-*	Right Side Assembly	X		
1	S501-500-*	Right Side Assembly		X	X
2	S153-326-*	Vestibule Service Door	X	X	X
3	105X1073	Right Evaporator Support Angle	X	X	X
4	541-266	Right Drain Pan Support Assembly	X	X	X
5	S523-123	Drain Pan Assembly	X	X	X
6	105-1080	Evaporator Coil Fill Angle	X	X	X
7	509-156	Upper Back	X	X	X
8	111-063	Supply Air Frame	2	2	2
9	103-439	Heat Exchanger Support Offset	X	X	X
10	Heat Exch Assy	See Burner Components Diagram			
11	105-1076	Top Heat Exchanger Deflector	X	X	X
12	135-216	Inner Air Baffle	X	X	X
13	165-563-*	Top Rain Channel	X	X	X
14	507-246-*	Top Assembly	X	X	X
15	135-184	Right Heat Exchanger Deflector	X	X	X
16	105Y1073	Left Evaporator Support Angle	X	X	X
17	105-1066	Lower Heat Exchanger Deflector	X	X	X
18	501-788-*	Left Side Assembly	X		
18	501-780-*	Left Side Assembly		X	X
19	543-070-*	Left Access Cover	X	X	X
20	105-1070	Left Support Angle	X	X	X
21	S120-484	Blower Partition	X	X	X
23	131-134	Filter Tray	X	X	X
24	1921-051	Vent Terminal Gasket	X	X	X
25	118-057-*	Side Grille	2		
25	118-058-*	Side Grille		2	2
<i>Continued on page 4</i>					

* Exterior cabinet parts are manufactured with various paint color options. To ensure the proper paint color is received, include the complete model number and serial number of the unit for which parts are being ordered.

Refer to drawing on page 2

CABINET COMPONENTS

Drawing No.	Part No.	Description	WG3S2	WG4S2	WG5S2
<i>Continued from page 3</i>					
27	S553-562-*	Filter Access Panel Assembly	X	X	X
28	S553-561-*	Front Door Assembly	X	X	X
29	553-327-*	Vent Option Door Assembly	X	X	X
30	169-119	Outer Vent Hood	X	X	X
31	169-120	Inner Vent Hood	X	X	X
32	WGBFAD-5	Barometric Fresh Air Damper	X	X	X
33	118-048-*	Condenser Grille	X		
33	118-052-*	Condenser Grille		X	X
34	549-131-*	Right Front Corner Assembly	X	X	X
35	S135-181-*	Air Intake Hood	X	X	X
36	S134-182-*	Air Intake Back	X	X	X
37	125-051	Fan Shroud	X		
37	125-050	Fan Shroud		X	X
38	542-072	Condenser Partition Blank Off Plate	X	X	X
39	541-398	Heat Exchanger Support Assembly	X	X	X
40	142-071	Filter Blank Off Plate	X	X	X
41	127-396	Lower Base	X	X	X
42	103-438	Lower Base Offset	3	3	3
43	Control Panel Assembly	See pages 12 and 13			
44	521-420	Condenser Partition Assembly	X	X	X
45	509-157	Lower Back Assembly	X		
45	509-205	Lower Back Assembly		X	X
46	113-268	Manifold Bracket	X	X	X
47	113-140	Bottom Support Bracket	X	X	X
48	S133-163	Circuit Breaker Inner Door 230V	X	X	X
48	S132-193	Circuit Breaker Inner Door 460V	X	X	X
49	S533-162-*	Control Panel Cover Assembly	X	X	X
50	S153-328-*	Disconnect Access Door	X	X	X
51	134-193	Conduit Access Panel	X	X	X
52	156-029	Conduit Entrance Plate	X	X	X
53	553-388-*	Upper Door Assembly	X	X	X

* Exterior cabinet parts are manufactured with various paint color options. To ensure the proper paint color is received, include the complete model number and serial number of the unit for which parts are being ordered.

Refer to drawing on Page 2

This page intentionally left blank.

FUNCTIONAL COMPONENTS

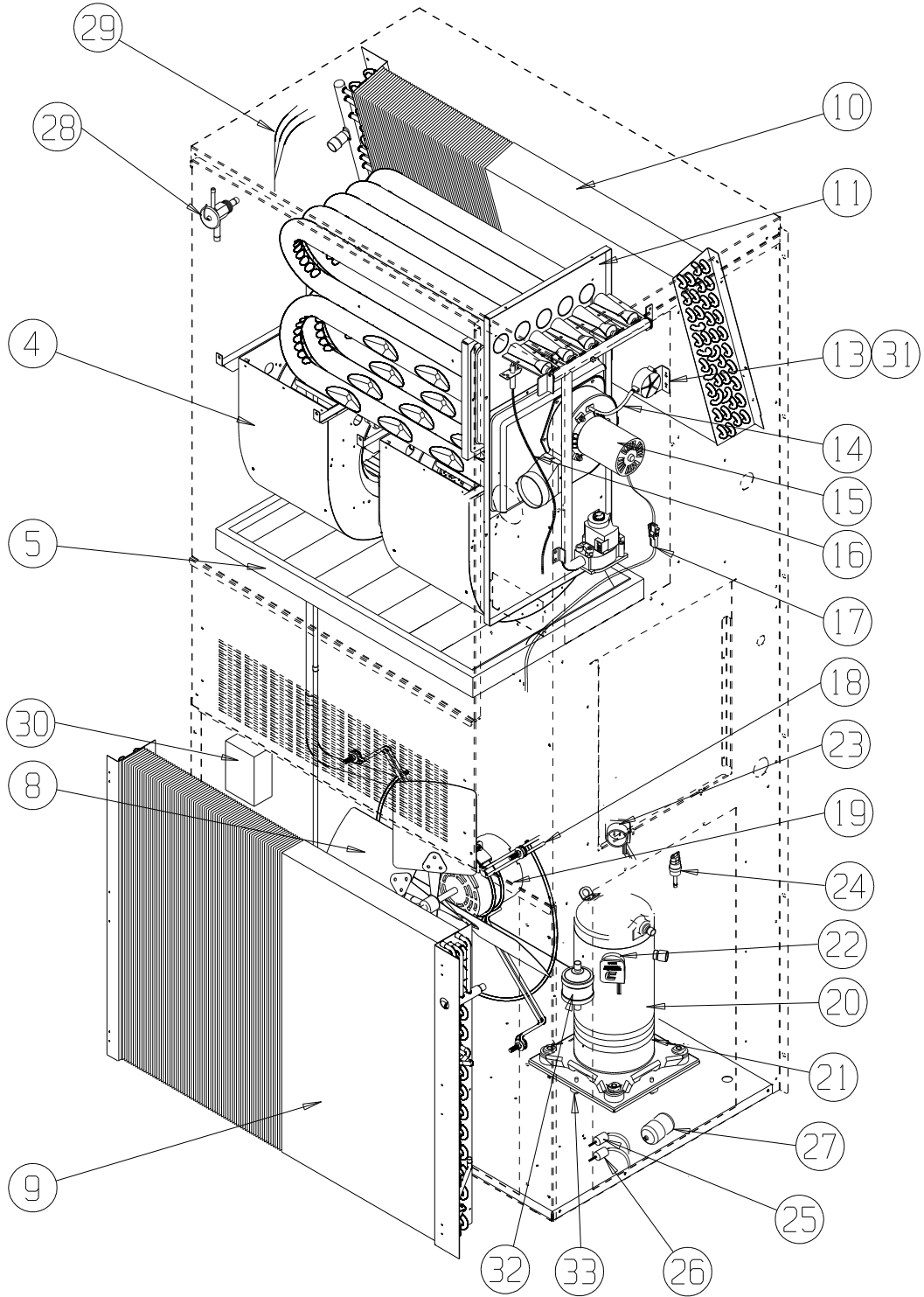

SEXP-679 A

FUNCTIONAL COMPONENTS

Drawing No.	Part No.	Description	WG3S2-A	WG3S2-B	WG3S2-C	WG4S2-A	WG4S2-B	WG4S2-C	WG5S2-A	WG5S2-B	WG5S2-C
4	Blower Assy	See page 14									
5	7004-027	20 x 30 x 2 Pleated Filter (Standard)	X	X	X	X	X	X	X	X	X
5	7003-030	20 x 30 x 1 Washable Filter (Optional)	X	X	X	X	X	X	X	X	X
8	5151-027	Fan Blade	X	X	X	X	X	X	X	X	X
9	5051-131BX	Coil	X	X	X						
9	5051-129BX	Coil				X	X	X	X	X	X
10	5060-106BX	Coil	X	X	X						
10	5060-105BX	Coil				X	X	X	X	X	X
11	Heat Exchanger	See Burner Components Diagram									
13	8406-103	.55" + .05" Pressure Switch	X	X	X	X	X	X	X	X	X
14	5452-008	6" Silicone Hose	X	X	X	X	X	X	X	X	X
15	8109-014	Induced Draft Blower 230V w/Transition	X	X		X	X		X	X	
15	8109-015	Induced Draft Blower 460V w/Transition			X			X			X
16	8600-011	Suppression Ignition Cable	X	X	X	X	X	X	X	X	X
17	3000-1255	Wire Assembly	X	X	X	X	X	X	X	X	X
18	8200-004	Fan Motor Mount	X	X	X	X	X	X	X	X	X
19	8105-039	Motor 230/208V	X	X		X	X		X	X	
19	8105-030	Motor 460V			X			X			X
20	8000-379	Compressor ZPS30K5E-PFV-130	X								
20	8000-380	Compressor ZPS30K5E-TF5-130		X							
20	8000-381	Compressor ZPS30K5E-TFD-130			X						
20	8000-382	Compressor ZPS40K5E-PFV-130				X					
20	8000-383	Compressor ZPS40K5E-TF5-130					X				
20	8000-384	Compressor ZPS40K5E-TFD-130						X			
20	8000-385	Compressor ZPS51K5E-PFV-130							X		
20	8000-386	Compressor ZPS51K5E-TF5-130								X	
20	8000-387	Compressor ZPS51K5E-TFD-130									X
21	8605-017	Compressor Crankcase Heater 230V				X	X		X	X	
21	8605-018	Compressor Crankcase Heater 460V						X			X
21	8605-019	Compressor Crankcase Heater 230V	X	X							
21	8605-020	Compressor Crankcase Heater 460V			X						
22	3000-1224	Compressor Power Plug with Wires	X								
22	3000-1231	Compressor Power Plug with Wires		X	X						
22	3000-1222	Compressor Power Plug with Wires				X			X		
22	3000-1230	Compressor Power Plug with Wires					X	X		X	X
23	3000-1223	Staging Solenoid Plug with Wires	X	X	X	X	X	X	X	X	X
24	1804-0386	Low Pressure Switch (Flare Tee)	X	X	X	X	X	X	X	X	X
25	1804-0327	High Pressure Switch (Flare Tee)	X	X	X	X	X	X	X	X	X
26	8406-112	Low Ambient Control Switch (Opt.)	X	X	X	X	X	X	X	X	X
27	5201-018	Refrigerant Filter Drier	X	X	X	X	X	X	X	X	X
28	5651-206	Refrigerant Expansion Valve	X	X	X						
28	5651-207	Refrigerant Expansion Valve				X	X	X			
28	5651-208	Refrigerant Expansion Valve							X	X	X
29	5625-008	Refrigerant Distributor	X	X	X						
29	5625-036	Refrigerant Distributor				X	X	X	X	X	X
30	8407-003	Step-Down Transformer			X						
30	8407-004	Step-Down Transformer						X			X
31	8620-189	High Altitude Pressure Switch Kit	X	X	X	X	X	X	X	X	X
32	5220-013	Discharge Muffler	X	X	X	X	X	X	X	X	X
33	5451-018	Lower Compressor Mounting Grommet	4	4	4	4	4	4	4	4	4
NS	8002-012	Compressor Sound Bag	X	X	X						
NS	8002-013	Compressor Sound Bag				X	X	X	X	X	X

BURNER COMPONENTS

Drawing No.	Part No.	Description	WG3S2-AXA	WG3S2-ANA	WG3S2-BXA	WG3S2-BNA	WG3S2-CXA	WG3S2-CNA	WG3S2-AXB	WG3S2-ANB	WG3S2-BXB	WG3S2-BNB	WG3S2-CXB	WG3S2-CNB	WG3S2-AXC	WG3S2-ANC	WG3S2-BXC	WG3S2-BNC	WG3S2-CXC	WG3S2-CNC	WG3S2-AXD	WG3S2-BXD	WG3S2-CXD
1	S171-326	Heat Exchanger Assembly 50K	X	X	X	X	X	X															
1	S171-328	Heat Exchanger Assembly 75K							X	X	X	X	X										
1	S171-330	Heat Exchanger Assembly 100K												X	X	X	X	X	X	X			
1	S171-332	Heat Exchanger Assembly 125K																			X	X	X
2	113-268	Manifold Bracket	X	X	X	X	X	X	X	X	X	X	X	X	X	X	X	X	X	X	X	X	X
4	8402-184	Limit Switch L300-30	X	X	X	X	X	X															
4	8402-183	Limit Switch L190-40							X	X	X	X	X										
4	8402-179	Limit Switch L130-30												X	X	X	X	X	X	X			
4	8402-178	Limit Switch L120-30																			X	X	X
5	9010-083	NOx Screen		2		2		2		3		3		3		4		4		4			
7	168-149	Collector Box	X	X	X	X	X	X															
7	168-126	Collector Box							X	X	X	X	X										
7	168-127	Collector Box												X	X	X	X	X	X	X			
7	168-128	Collector Box																			X	X	X
8	1921-044	Gasket Set	X	X	X	X	X	X	X	X	X	X	X	X	X	X	X	X	X	X	X	X	X
9	5809-017	3.031" x 4.625" Transition	X	X	X	X	X	X	X	X	X	X	X	X	X	X	X	X	X	X	X	X	X
11	9010-079	Orifice 2.40mm (0.0960 diameter)	2		2		2		3		3		3		4		4		4		5	5	5
11	9010-082	Orifice 2.30mm (10% derate & .0905 diameter)	2	2	2	2	2	2	3	3	3	3	3	3	4	4	4	4	4	4	5	5	5
12	1012-314	U-Clip Fastener	4	4	4	4	4	4	4	4	4	4	4	4	4	4	4	4	4	4	4	4	4
13	163-050	Burner Box	X	X	X	X	X	X															
13	163-049	Burner Box							X	X	X	X	X										
13	163-052	Burner Box												X	X	X	X	X	X	X			
13	163-051	Burner Box																			X	X	X
14	141-440	Flame Rollout Support	X	X	X	X	X	X	X	X	X	X	X										
14	141-438	Flame Rollout Support												X	X	X	X	X	X	X			
14	141-439	Flame Rollout Support																			X	X	X
15	8402-124	Flame Rollout Switch L270	X	X	X	X	X	X	X	X	X	X	X	X	X	X	X	X	X	X	X	X	X
16	9010-078	In-Shot Burner 2.5 x 4.5	2	2	2	2	2	2	3	3	3	3	3	3	4	4	4	4	4	4	5	5	5
17	163-048	Burner Support	X	X	X	X	X	X															
17	163-041	Burner Support							X	X	X	X	X										
17	163-043	Burner Support												X	X	X	X	X	X	X			
17	163-045	Burner Support																			X	X	X
18	8554-024	DSI Spark Ignitor	X	X	X	X	X	X	X	X	X	X	X	X	X	X	X	X	X	X	X	X	X
19	8554-025	Flame Sensor	X	X	X	X	X	X	X	X	X	X	X	X	X	X	X	X	X	X	X	X	X
20	5818-053	2-Hole Gas Manifold	X	X	X	X	X	X															
20	5818-054	3-Hole Gas Manifold							X	X	X	X	X										
20	5818-055	4-Hole Gas Manifold												X	X	X	X	X	X	X			
20	5818-056	5-Hole Gas Manifold																			X	X	X
21	5651-160	Natural Gas Valve 1/2" x 1/2"	X	X	X	X	X	X	X	X	X	X	X	X	X	X	X	X	X	X	X	X	X
22	168-140	Tube Brace 2-Burner	X	X	X	X	X	X															
22	168-135	Tube Brace 3-Burner							X	X	X	X	X										
22	168-134	Tube Brace 4-Burner												X	X	X	X	X	X	X			
22	168-133	Tube Brace 5-Burner																			X	X	X
23	112-355	Limit Bracket	X	X	X	X	X	X															
23	113-475	Limit Bracket							X	X	X	X	X	X	X	X	X	X	X	X	X	X	X
NS	WGCK-1	Propane Conversion Kit (0-6000' Altitude)	X	X	X	X	X	X	X	X	X	X	X	X	X	X	X	X	X	X	X	X	X
NS	WGCK-3	Propane Conversion Kit (6-10000' Altitude)	X	X	X	X	X	X	X	X	X	X	X	X	X	X	X	X	X	X	X	X	X
NS	4085-154	Wiring Diagram	X	X											X	X							
NS	4085-155	Ladder Diagram	X	X											X	X							
NS	4085-156	Wiring Diagram							X	X											X		
NS	4085-157	Ladder Diagram							X	X											X		
NS	4085-254	Wiring Diagram			X	X										X	X						
NS	4085-269	Ladder Diagram			X	X										X	X						
NS	4085-255	Wiring Diagram									X	X											X
NS	4085-270	Ladder Diagram									X	X											X
NS	4085-377	Wiring Diagram					X	X												X	X		
NS	4085-392	Ladder Diagram					X	X											X	X			
NS	4085-378	Wiring Diagram											X	X									X
NS	4085-393	Ladder Diagram											X	X									X
NS	900-285-001	Complete Blower Assembly	X	X	X	X	X	X	X	X	X	X	X	X									
NS	900-285-002	Complete Blower Assembly													X	X	X	X	X	X	X	X	X

BURNER COMPONENTS

Drawing No.	Part No.	Description	WG4S2-AXA	WG4S2-ANA	WG4S2-BXA	WG4S2-BNA	WG4S2-CXA	WG4S2-CNA	WG4S2-AXB	WG4S2-ANB	WG4S2-BXB	WG4S2-BNB	WG4S2-CXB	WG4S2-CNB	WG4S2-AXC	WG4S2-ANC	WG4S2-BXC	WG4S2-BNC	WG4S2-CXC	WG4S2-CNC	WG4S2-AXD	WG4S2-BXD	WG4S2-CXD
1	S171-326	Heat Exchanger Assembly 50K	X	X	X	X	X	X															
1	S171-328	Heat Exchanger Assembly 75K							X	X	X	X	X	X									
1	S171-330	Heat Exchanger Assembly 100K													X	X	X	X	X	X	X	X	X
1	S171-332	Heat Exchanger Assembly 125K																			X	X	X
2	113-268	Manifold Bracket	X	X	X	X	X	X	X	X	X	X	X	X	X	X	X	X	X	X	X	X	X
4	8402-184	Limit Switch L300-30	X	X	X	X	X	X															
4	8402-183	Limit Switch L190-40							X	X	X	X	X	X									
4	8402-181	Limit Switch L150-30													X	X	X	X	X	X			
4	8402-179	Limit Switch L130-30																			X	X	X
5	9010-083	NOx Screen		2		2		2		3		3		3		4		4		4			
7	168-149	Collector Box	X	X	X	X	X	X															
7	168-126	Collector Box							X	X	X	X	X	X									
7	168-127	Collector Box													X	X	X	X	X	X			
7	168-128	Collector Box																			X	X	X
8	1921-044	Gasket Set	X	X	X	X	X	X	X	X	X	X	X	X	X	X	X	X	X	X	X	X	X
9	5809-017	3.031" x 4.625" Transition	X	X	X	X	X	X	X	X	X	X	X	X	X	X	X	X	X	X	X	X	X
11	9010-079	Orifice 2.40mm (0.0960 diameter)	2	2	2	2	2	2	3	3	3	3	3	3	4	4	4	4	4	4	5	5	5
11	9010-082	Orifice 2.30mm (10% derate & .0905 diameter)	2	2	2	2	2	2	3	3	3	3	3	3	4	4	4	4	4	4	5	5	5
12	1012-314	U-Clip Fastener	4	4	4	4	4	4	4	4	4	4	4	4	4	4	4	4	4	4	4	4	4
13	163-050	Burner Box	X	X	X	X	X	X															
13	163-049	Burner Box							X	X	X	X	X	X									
13	163-052	Burner Box													X	X	X	X	X	X			
13	163-051	Burner Box																			X	X	X
14	141-440	Flame Rollout Support	X	X	X	X	X	X	X	X	X	X	X	X									
14	141-438	Flame Rollout Support													X	X	X	X	X	X			
14	141-439	Flame Rollout Support																			X	X	X
15	8402-124	Flame Rollout Switch L270	X	X	X	X	X	X	X	X	X	X	X	X	X	X	X	X	X	X	X	X	X
16	9010-078	In-Shot Burner 2.5 x 4.5	2	2	2	2	2	2	3	3	3	3	3	3	4	4	4	4	4	4	5	5	5
17	163-048	Burner Support	X	X	X	X	X	X															
17	163-041	Burner Support							X	X	X	X	X	X									
17	163-043	Burner Support													X	X	X	X	X	X			
17	163-045	Burner Support																			X	X	X
18	8554-024	DSI Spark Ignitor	X	X	X	X	X	X	X	X	X	X	X	X	X	X	X	X	X	X	X	X	X
19	8554-025	Flame Sensor	X	X	X	X	X	X	X	X	X	X	X	X	X	X	X	X	X	X	X	X	X
20	5818-053	2-Hole Gas Manifold	X	X	X	X	X	X															
20	5818-054	3-Hole Gas Manifold							X	X	X	X	X	X									
20	5818-055	4-Hole Gas Manifold													X	X	X	X	X	X			
20	5818-056	5-Hole Gas Manifold																			X	X	X
21	5651-160	Natural Gas Valve 1/2" x 1/2"	X	X	X	X	X	X	X	X	X	X	X	X	X	X	X	X	X	X	X	X	X
22	168-140	Tube Brace 2-Burner	X	X	X	X	X	X															
22	168-135	Tube Brace 3-Burner							X	X	X	X	X	X									
22	168-134	Tube Brace 4-Burner													X	X	X	X	X	X			
22	168-133	Tube Brace 5-Burner																			X	X	X
23	112-355	Limit Bracket	X	X	X	X	X	X															
23	113-475	Limit Bracket							X	X	X	X	X	X							X	X	X
NS	WGCK-1	Propane Conversion Kit (0-6000' Altitude)	X	X	X	X	X	X	X	X	X	X	X	X	X	X	X	X	X	X	X	X	X
NS	WGCK-3	Propane Conversion Kit (6-10000' Altitude)	X	X	X	X	X	X	X	X	X	X	X	X	X	X	X	X	X	X	X	X	X
NS	4085-154	Wiring Diagram	X	X											X	X							
NS	4085-155	Ladder Diagram	X	X											X	X							
NS	4085-156	Wiring Diagram							X	X											X		
NS	4085-157	Ladder Diagram							X	X											X		
NS	4085-254	Wiring Diagram			X	X											X	X					
NS	4085-269	Ladder Diagram			X	X											X	X					
NS	4085-255	Wiring Diagram									X	X										X	
NS	4085-270	Ladder Diagram									X	X										X	
NS	4085-377	Wiring Diagram				X	X											X	X				
NS	4085-392	Ladder Diagram				X	X										X	X					
NS	4085-378	Wiring Diagram											X	X									X
NS	4085-393	Ladder Diagram											X	X									X
NS	900-285-001	Complete Blower Assembly	X	X	X	X	X	X	X	X	X	X	X	X									
NS	900-285-002	Complete Blower Assembly													X	X	X	X	X	X	X	X	X

BURNER COMPONENTS

Drawing No.	Part No.	Description	WG5S2-AXA	WG5S2-ANA	WG5S2-BXA	WG5S2-BNA	WG5S2-CXA	WG5S2-CNA	WG5S2-AXB	WG5S2-ANB	WG5S2-BXB	WG5S2-BNB	WG5S2-CXB	WG5S2-CNB	WG5S2-AXC	WG5S2-ANC	WG5S2-BXC	WG5S2-BNC	WG5S2-CXC	WG5S2-CNC	WG5S2-AXD	WG5S2-BXD	WG5S2-CXD
1	S171-326	Heat Exchanger Assembly 50K	X	X	X	X	X	X															
1	S171-328	Heat Exchanger Assembly 75K							X	X	X	X	X	X									
1	S171-330	Heat Exchanger Assembly 100K													X	X	X	X	X	X			
1	S171-332	Heat Exchanger Assembly 125K																			X	X	X
2	113-268	Manifold Bracket	X	X	X	X	X	X	X	X	X	X	X	X	X	X	X	X	X	X	X	X	X
4	8402-184	Limit Switch L300-30	X	X	X	X	X	X															
4	8402-183	Limit Switch L190-40							X	X	X	X	X										
4	8402-181	Limit Switch L150-30												X	X	X	X	X	X				
4	8402-179	Limit Switch L130-30																			X	X	X
5	9010-083	NOx Screen		2		2		2		3		3		3		4		4		4			
7	168-149	Collector Box	X	X	X	X	X	X															
7	168-126	Collector Box							X	X	X	X	X	X									
7	168-127	Collector Box													X	X	X	X	X	X			
7	168-128	Collector Box																			X	X	X
8	1921-044	Gasket Set	X	X	X	X	X	X	X	X	X	X	X	X	X	X	X	X	X	X	X	X	X
9	5809-017	3.031" x 4.625" Transition	X	X	X	X	X	X	X	X	X	X	X	X	X	X	X	X	X	X	X	X	X
11	9010-079	Orifice 2.40mm (0.0960 diameter)	2	2	2	2	2	2	3	3	3	3	3	3	4	4	4	4	4	4	5	5	5
11	9010-082	Orifice 2.30mm (10% derate & .0905 diameter)	2	2	2	2	2	2	3	3	3	3	3	3	4	4	4	4	4	4	5	5	5
12	1012-314	U-Clip Fastener	4	4	4	4	4	4	4	4	4	4	4	4	4	4	4	4	4	4	4	4	4
13	163-050	Burner Box	X	X	X	X	X	X															
13	163-049	Burner Box							X	X	X	X	X	X									
13	163-052	Burner Box													X	X	X	X	X	X			
13	163-051	Burner Box																			X	X	X
14	141-440	Flame Rollout Support	X	X	X	X	X	X	X	X	X	X	X	X									
14	141-438	Flame Rollout Support													X	X	X	X	X	X			
14	141-439	Flame Rollout Support																			X	X	X
15	8402-124	Flame Rollout Switch L270	X	X	X	X	X	X	X	X	X	X	X	X	X	X	X	X	X	X	X	X	X
16	9010-078	In-Shot Burner 2.5 x 4.5	2	2	2	2	2	2	3	3	3	3	3	3	4	4	4	4	4	4	5	5	5
17	163-048	Burner Support	X	X	X	X	X	X															
17	163-041	Burner Support							X	X	X	X	X	X									
17	163-043	Burner Support													X	X	X	X	X	X			
17	163-045	Burner Support																			X	X	X
18	8554-024	DSI Spark Ignitor	X	X	X	X	X	X	X	X	X	X	X	X	X	X	X	X	X	X	X	X	X
19	8554-025	Flame Sensor	X	X	X	X	X	X	X	X	X	X	X	X	X	X	X	X	X	X	X	X	X
20	5818-053	2-Hole Gas Manifold	X	X	X	X	X	X															
20	5818-054	3-Hole Gas Manifold							X	X	X	X	X	X									
20	5818-055	4-Hole Gas Manifold													X	X	X	X	X	X			
20	5818-056	5-Hole Gas Manifold																			X	X	X
21	5651-160	Natural Gas Valve 1/2" x 1/2"	X	X	X	X	X	X	X	X	X	X	X	X	X	X	X	X	X	X	X	X	X
22	168-140	Tube Brace 2-Burner	X	X	X	X	X	X															
22	168-135	Tube Brace 3-Burner							X	X	X	X	X	X									
22	168-134	Tube Brace 4-Burner													X	X	X	X	X	X			
22	168-133	Tube Brace 5-Burner																			X	X	X
23	112-355	Limit Bracket	X	X	X	X	X	X															
23	113-475	Limit Bracket							X	X	X	X	X	X	X	X	X	X	X	X	X	X	X
NS	WGCK-1	Propane Conversion Kit (0-6000' Altitude)	X	X	X	X	X	X	X	X	X	X	X	X	X	X	X	X	X	X	X	X	X
NS	WGCK-3	Propane Conversion Kit (6-10000' Altitude)	X	X	X	X	X	X	X	X	X	X	X	X	X	X	X	X	X	X	X	X	X
NS	4085-154	Wiring Diagram	X	X											X	X							
NS	4085-155	Ladder Diagram	X	X											X	X							
NS	4085-156	Wiring Diagram							X	X											X		
NS	4085-157	Ladder Diagram							X	X											X		
NS	4085-254	Wiring Diagram			X	X											X	X					
NS	4085-269	Ladder Diagram			X	X											X	X					
NS	4085-255	Wiring Diagram									X	X										X	
NS	4085-270	Ladder Diagram									X	X										X	
NS	4085-377	Wiring Diagram					X	X											X	X			
NS	4085-392	Ladder Diagram					X	X											X	X			
NS	4085-378	Wiring Diagram											X	X									X
NS	4085-393	Ladder Diagram											X	X									X
NS	900-286-003	Complete Blower Assembly	X	X	X	X	X	X	X	X	X	X	X	X									
NS	900-286-004	Complete Blower Assembly													X	X	X	X	X	X	X	X	X

CONTROL PANEL

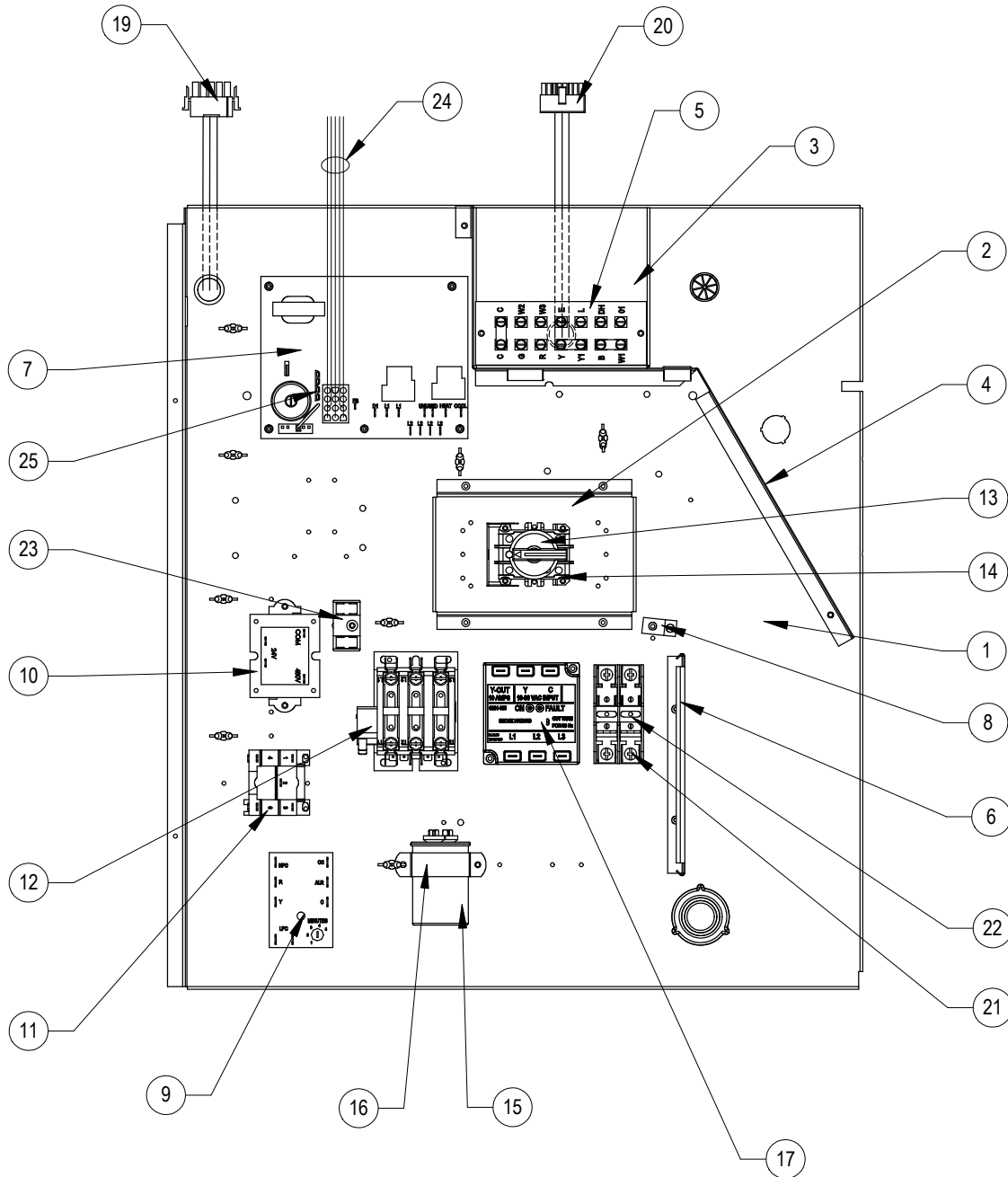

SEXP-680

CONTROL PANEL

Drawing No.	Part No.	Description	WG3S2-A	WG3S2-B	WG3S2-C	WG4S2-A	WG4S2-B	WG4S2-C	WG5S2-A	WG5S2-B	WG5S2-C
1	517-276	Control Box Wrapper	X	X	X	X	X	X	X	X	X
2	113-269	Circuit Breaker Base	X	X	X	X	X	X	X	X	X
3	117-247	Low Voltage Box	X	X	X	X	X	X	X	X	X
4	117-248	Low Voltage Partition	X	X	X	X	X	X	X	X	X
5	8607-024	Low Voltage Terminal Strip	X	X	X	X	X	X	X	X	X
6	135-130	Wire Shield	X	X	X	X	X	X	X	X	X
7	5651-159	Integrated Control Board	X	X	X	X	X	X	X	X	X
8	8611-009	Ground Lug	X	X	X	X	X	X	X	X	X
9	8201-088	Compressor Controle Module	X	X	X	X	X	X	X	X	X
10	8407-035	Transformer	X	X		X	X		X	X	
10	8407-042	Transformer			X			X			X
11	8201-009	Draft Inducer Motor Relay	X	X		X	X		X	X	
11	8201-032	Draft Inducer Motor Relay			X			X			X
12	8401-027	Compressor Contactor	X	X	X	X	X	X	X	X	X
13	8615-071	Rotary Disconnect Handle			X			X			X
14	8615-055	Circuit Breaker 40 Amp, 2-Pole	X			X					
14	8615-052	Circuit Breaker 30 Amp, 3-Pole		X							
14	8615-068	Rotary Disconnect			X			X			X
14	8615-043	Circuit Breaker 40 Amp, 3-Pole				X				X	
14	8615-040	Circuit Breaker 50 Amp, 2-Pole							X		
15	8552-080	Capacitor 40/10 MFD 370V	X								
15	8552-005	Capacitor 10 MFD 370V		X			X			X	
15	8552-026	Capacitor 15 MFD370V			X			X			X
15	8552-094	Capacitor 30/10 MFD 370V				X					
15	8552-055	Capacitor 40/10 MFD 440V							X		
16	8550-007	Capacitor Bracket, 2" Round	X								
16	8550-003	Capacitor Bracket, 1-1/4" Oval		X			X			X	
16	8550-008	Capacitor Bracket, 2-1/2" Round			X			X			
16	8550-006	Capacitor Bracket, 1-3/4" Round			X		X				X
17	8201-085	Phase Monitor		X	X		X	X		X	X
19	3000-1265	Blower Motor Power Wire Harness	X	X	X	X	X	X	X	X	X
20	3000-1254	Blower Motor Control Wire Harness	X	X	X	X	X	X	X	X	X
21	8615-041	Fuse Block			X			X			X
22	8614-046	5 Amp Class CC Fuse			2						
22	8614-042	7 Amp Class CC Fuse						2			2
23	8607-017	Terminal Block 240V 2 Terminal			X			X			X
24	3000-1253	IFC Wire Assembly	X	X	X	X	X	X	X	X	X
25	8614-045	3 Amp Fuse	X	X	X	X	X	X	X	X	X
NS	134-247	Wire Shield			X			X			X

NS – Not Shown

BLOWER ASSEMBLY

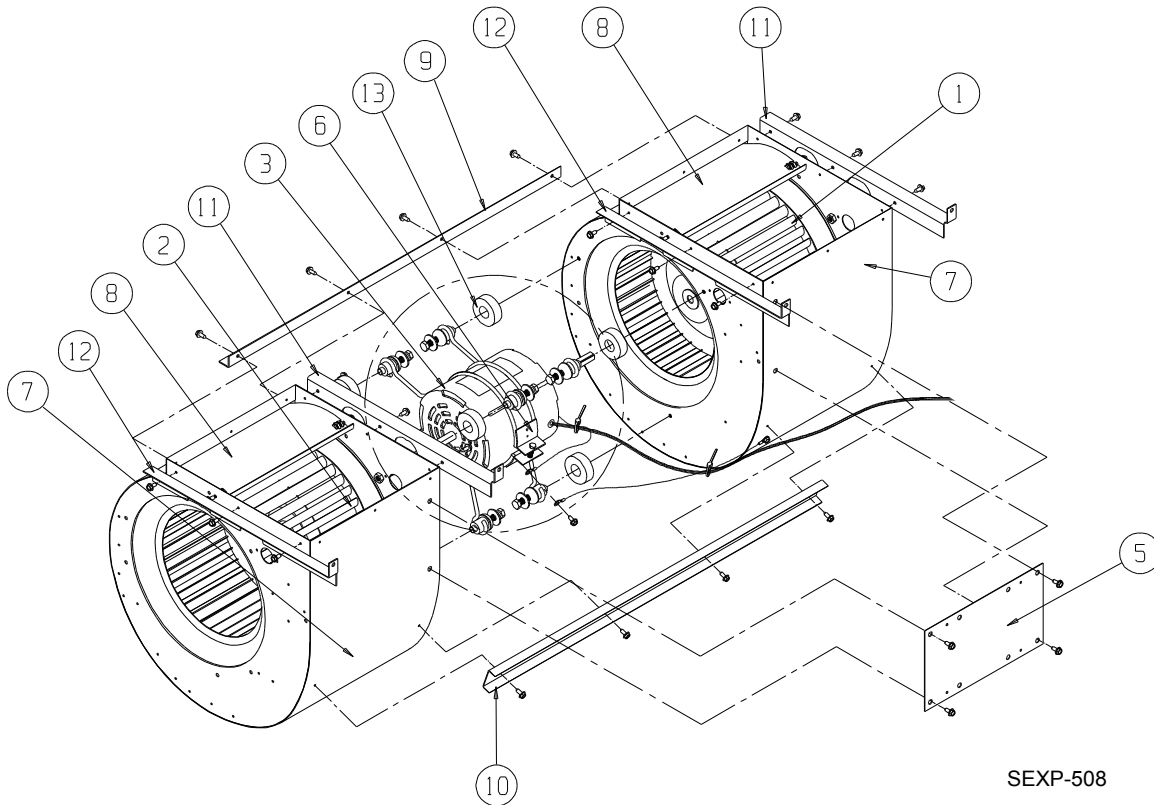

SEXP-508

Drawing No.	Part No.	Description	900-285-001	900-285-002	900-286-001	900-286-002	900-286-003	900-286-004
1	5152-011	Blower Wheel 10-8	X	X	X	X	X	X
2	5152-012	Blower Wheel 10-8	X	X	X	X	X	X
3*	8106-052-0045	1/2 HP Programmed Motor w/Control	X					
3*	8106-052-0051	1/2 HP Programmed Motor w/Control		X				
3*	8107-017-0046	3/4 HP Programmed Motor w/Control			X			
3*	8107-017-0052	3/4 HP Programmed Motor w/Control				X		
3*	8107-017-0047	3/4 HP Programmed Motor w/Control					X	
3*	8107-017-0053	3/4 HP Programmed Motor w/Control						X
5	112-344	Control Mounting Plate	X	X	X	X	X	X
6	8200-040	Motor Mount	X	X	X	X	X	X
7	151-101	Blower Housing	2	2	2	2	2	2
8	144-166	Diffuser	2	2	2	2	2	2
9	105-881	Angle – Back	X	X	X	X	X	X
10	165-564	Channel – Front	X	X	X	X	X	X
11	105X1075	Angle – Right	2	2	2	2	2	2
12	105Y1075	Angle – Left	2	2	2	2	2	2
13	5451-011	Grommets	6	6	6	6	6	6

* Refer to pages 9, 10 & 11 where both cooling and heating capacities are listed to match proper blower assembly internal parts required for specific application. They are listed at the bottom of the chart as NS (not shown).