

REPLACEMENT PARTS MANUAL

WALL MOUNTED GAS/ELECTRIC

MODELS:

W42G2DA	W42G2DB	W42G2DC
W48G2DA	W48G2DB	W48G2DC
W60G2DA	W60G2DB	W60G2DC

General Notes

- Revised and/or additional pages may be issued from time to time.
- A complete and current manual consists of pages shown in the following contents section.

Important

- Contact the installing and/or local Bard distributor for all parts requirements. Make sure you have the complete model and serial number available from the unit rating plates.

Contents

<i>Description</i>	<i>Page</i>
Cabinet Components	
♦ Exploded View	2
♦ Usage List	3
♦ Usage List	4
♦ Usage List	5
♦ Usage List	6
♦ Usage List	7
♦ Usage List	8
♦ Blank Page	9
Functional Components	
♦ Exploded View	10
♦ Usage List	11
♦ Usage List	12
♦ Usage List	13
Burner Components	
♦ Exploded View	14
♦ Usage List	15
♦ Usage List	16
♦ Usage List	17
Control Panel	
♦ Layout	18
♦ Usage List	19
Blower Assembly	
♦ Exploded View	20
♦ Usage List	20



Bard Manufacturing Company, Inc.
Bryan, Ohio 43506
Since 1914...Moving ahead, just as planned.

Manual: 2110-816
Supersedes: **NEW**
File: Vol. III Tab 20
Date: 04-10-13

CABINET COMPONENTS

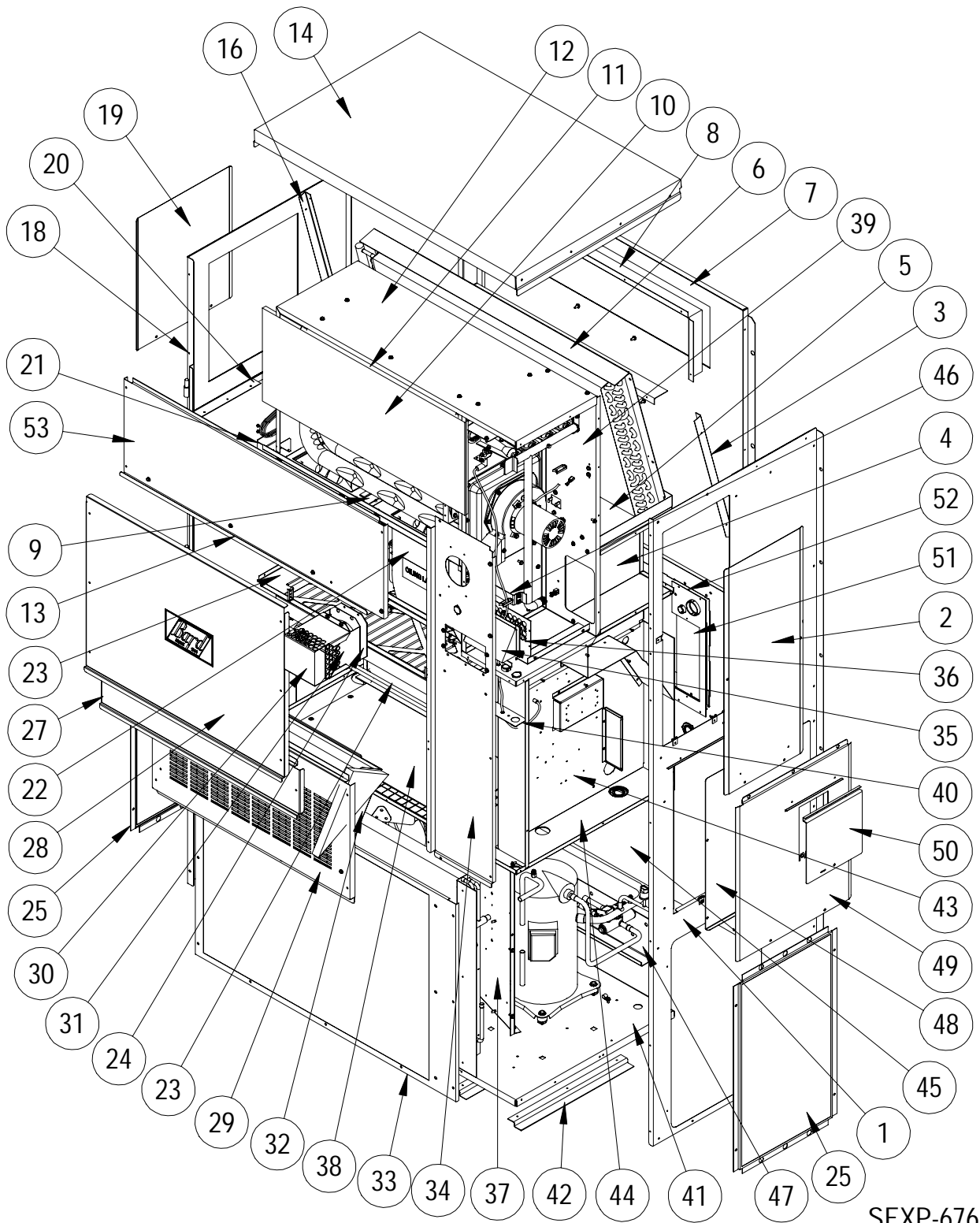

This drawing to be used for reference for Pages 3, 4, 5, 6, 7 and 8.

CABINET COMPONENTS

Drawing No.	Part No.	Description	W42G2DAXB	W42G2DAXC	W42G2DAXD	W42G2DBXB	W42G2DBXC	W42G2DBXD	W42G2DCXB	W42G2DCXC	W42G2DCXD
1	501-570-*	Right Side Assembly	X	X	X	X	X	X	X	X	X
2	S153-326-*	Vestibule Service Door	X	X	X	X	X	X	X	X	X
3	105X1073	Right Evaporator Support Angle	X	X	X	X	X	X	X	X	X
4	541-266	Right Drain Pan Support Assembly	X	X	X	X	X	X	X	X	X
5	S523-123	Drain Pan Assembly	X	X	X	X	X	X	X	X	X
6	105-1080	Evaporator Coil Fill Angle	X	X	X	X	X	X	X	X	X
7	509-156	Upper Back	X	X	X	X	X	X	X	X	X
8	111-063	Supply Air Frame	2	2	2	2	2	2	2	2	2
9	103-439	Heat Exchanger Support Offset	X	X	X	X	X	X	X	X	X
10	Heat Exch Assy	See Burner Components Diagram									
11	105-1066	Top Heat Exchanger Deflector	X	X	X	X	X	X	X	X	X
12	135-216	Inner Air Baffle	X	X	X	X	X	X	X	X	X
13	165-563-*	Top Rain Channel	X	X	X	X	X	X	X	X	X
14	507-246-*	Top Assembly	X	X	X	X	X	X	X	X	X
15	135-184	Right Heat Exchanger Deflector	X	X	X	X	X	X	X	X	X
16	105Y1073	Left Evaporator Support Angle	X	X	X	X	X	X	X	X	X
17	105-1076	Lower Heat Exchanger Deflector	X	X	X	X	X	X	X	X	X
18	501-571-*	Left Side Assembly	X	X	X	X	X	X	X	X	X
19	543-070-*	Left Access Cover	X	X	X	X	X	X	X	X	X
20	105-1070	Left Support Angle	X	X	X	X	X	X	X	X	X
21	S121-484	Blower Partition	X	X	X	X	X	X	X	X	X
22	S900-249	Complete Blower Assembly - 230V	X	X	X	X	X				
22	S900-277	Complete Blower Assembly - 460V							X	X	X
23	131-163	Filter Tray	X	X	X	X	X	X	X	X	X
24	1921-051	Vent Terminal Gasket	X	X	X	X	X	X	X	X	X
25	118-084-*	Side Grille	2	2	2	2	2	2	2	2	2
Continued on Page 4											

* Exterior cabinet parts are manufactured with various paint color options. To ensure that you receive the proper paint color, you must include the complete model and serial number of the unit for which cabinet parts are being ordered.

Refer to drawing on Page 2

CABINET COMPONENTS

Drawing No.	Part No.	Description	W42G2DAXB	W42G2DAXC	W42G2DAXD	W42G2DBXB	W42G2DBXC	W42G2DBXD	W42G2DCXB	W42G2DCXC	W42G2DCXD
Continued from Page 3											
27	S553-562-*	Filter Access Panel Assembly	X	X	X	X	X	X	X	X	X
28	S553-561-*	Front Door Assembly	X	X	X	X	X	X	X	X	X
29	553-327-*	Vent Option Door Assembly	X	X	X	X	X	X	X	X	X
30	169-119	Outer Vent Hood	X	X	X	X	X	X	X	X	X
31	169-120	Inner Vent Hood	X	X	X	X	X	X	X	X	X
32	WGBFAD-5	Barometric Fresh Air Damper	X	X	X	X	X	X	X	X	X
33	118-048-*	Condenser Grille	X	X	X	X	X	X	X	X	X
34	549-131-*	Right Front Corner Assembly	X	X	X	X	X	X	X	X	X
35	S135-181-*	Air Intake Hood	X	X	X	X	X	X	X	X	X
36	S134-182-*	Air Intake Back	X	X	X	X	X	X	X	X	X
37	125-024	Fan Shroud	X	X	X	X	X	X	X	X	X
38	542-136	Condenser Partition Blank Off Plate	X	X	X	X	X	X	X	X	X
39	541-398	Heat Exchanger Support Assembly	X	X	X	X	X	X	X	X	X
40	142-071	Filter Blank Off Plate	X	X	X	X	X	X	X	X	X
41	127-302	Lower Base	X	X	X	X	X	X	X	X	X
42	103-438	Lower Base Offset	3	3	3	3	3	3	3	3	3
43	S902-1484	Control Panel Assembly	X	X	X						
43	S902-1485	Control Panel Assembly				X	X	X			
43	S902-1486	Control Panel Assembly							X	X	X
44	521-447	Condenser Partition Assembly	X	X	X	X	X	X	X	X	X
45	509-157	Lower Back Assembly	X	X	X	X	X	X	X	X	X
46	113-268	Manifold Bracket	X	X	X	X	X	X	X	X	X
47	113-140	Bottom Support Bracket	X	X	X	X	X	X	X	X	X
48	S133-163	Circuit Breaker Inner Door	X	X	X	X	X	X			
48	S133-205	Toggle Disconnect Inner Door							X	X	X
49	S533-162-*	Control Panel Cover Assembly	X	X	X	X	X	X	X	X	X
50	S153-328-*	Disconnect Access Door	X	X	X	X	X	X	X	X	X
51	156-029	Conduit Entrance Plate	X	X	X	X	X	X	X	X	X
52	134-193	Conduit Access Panel	X	X	X	X	X	X	X	X	X
53	553-388-*	Upper Door Assembly	X	X	X	X	X	X	X	X	X

* Exterior cabinet parts are manufactured with various paint color options. To ensure that you receive the proper paint color, you must include the complete model and serial number of the unit for which cabinet parts are being ordered.

Refer to drawing on Page 2

CABINET COMPONENTS

Drawing No.	Part No.	Description	W48G2DAXB	W48G2DAXC	W48G2DAXD	W48G2DBXB	W48G2DBXC	W48G2DBXD	W48G2DCXB	W48G2DCXC	W48G2DCXD
1	501-570-*	Right Side Assembly	X	X	X	X	X	X	X	X	X
2	S153-326-*	Vestibule Service Door	X	X	X	X	X	X	X	X	X
3	105X1073	Right Evaporator Support Angle	X	X	X	X	X	X	X	X	X
4	541-266	Right Drain Pan Support Assembly	X	X	X	X	X	X	X	X	X
5	S523-123	Drain Pan Assembly	X	X	X	X	X	X	X	X	X
6	105-1080	Evaporator Coil Fill Angle	X	X	X	X	X	X	X	X	X
7	509-156	Upper Back	X	X	X	X	X	X	X	X	X
8	111-063	Supply Air Frame	2	2	2	2	2	2	2	2	2
9	103-439	Heat Exchanger Support Offset	X	X	X	X	X	X	X	X	X
10	Heat Exch Assy	See Burner Components Diagram									
11	105-1066	Top Heat Exchanger Deflector	X	X	X	X	X	X	X	X	X
12	135-216	Inner Air Baffle	X	X	X	X	X	X	X	X	X
13	165-563-*	Top Rain Channel	X	X	X	X	X	X	X	X	X
14	507-246-*	Top Assembly	X	X	X	X	X	X	X	X	X
15	135-184	Right Heat Exchanger Deflector	X	X	X	X	X	X	X	X	X
16	105Y1073	Left Evaporator Support Angle	X	X	X	X	X	X	X	X	X
17	105-1076	Lower Heat Exchanger Deflector	X	X	X	X	X	X	X	X	X
18	501-571-*	Left Side Assembly	X	X	X	X	X	X	X	X	X
19	543-070-*	Left Access Cover	X	X	X	X	X	X	X	X	X
20	105-1070	Left Support Angle	X	X	X	X	X	X	X	X	X
21	S121-484	Blower Partition	X	X	X	X	X	X	X	X	X
22	S900-249	Complete Blower Assembly - 230V	X	X	X	X	X				
22	S900-277	Complete Blower Assembly - 460V						X	X	X	
23	131-163	Filter Tray	X	X	X	X	X	X	X	X	X
24	1921-051	Vent Terminal Gasket	X	X	X	X	X	X	X	X	X
25	118-084-*	Side Grille	2	2	2	2	2	2	2	2	2
Continued on Page 6											

* Exterior cabinet parts are manufactured with various paint color options. To ensure that you receive the proper paint color, you must include the complete model and serial number of the unit for which cabinet parts are being ordered.

Refer to drawing on Page 2

CABINET COMPONENTS

Drawing No.	Part No.	Description	W48G2DAXB	W48G2DAXC	W48G2DAXD	W48G2DBXB	W48G2DBXC	W48G2DBXD	W48G2DCXB	W48G2DCXC	W48G2DCXD
Continued from Page 5											
27	S553-562-*	Filter Access Panel Assembly	X	X	X	X	X	X	X	X	X
28	S553-561-*	Front Door Assembly	X	X	X	X	X	X	X	X	X
29	553-327-*	Vent Option Door Assembly	X	X	X	X	X	X	X	X	X
30	169-119	Outer Vent Hood	X	X	X	X	X	X	X	X	X
31	169-120	Inner Vent Hood	X	X	X	X	X	X	X	X	X
32	WGBFAD-5	Barometric Fresh Air Damper	X	X	X	X	X	X	X	X	X
33	118-048-*	Condenser Grille	X	X	X	X	X	X	X	X	X
34	549-131-*	Right Front Corner Assembly	X	X	X	X	X	X	X	X	X
35	S135-181-*	Air Intake Hood	X	X	X	X	X	X	X	X	X
36	S134-182-*	Air Intake Back	X	X	X	X	X	X	X	X	X
37	125-024	Fan Shroud	X	X	X	X	X	X	X	X	X
38	542-136	Condenser Partition Blank Off Plate	2	2	2	2	2	2	2	2	2
39	541-398	Heat Exchanger Support Assembly	X	X	X	X	X	X	X	X	X
40	142-071	Filter Blank Off Plate	X	X	X	X	X	X	X	X	X
41	127-302	Lower Base	X	X	X	X	X	X	X	X	X
42	103-438	Lower Base Offset	3	3	3	3	3	3	3	3	3
43	S902-1487	Control Panel Assembly	X	X	X						
43	S902-1488	Control Panel Assembly				X	X	X			
43	S902-1489	Control Panel Assembly							X	X	X
44	521-447	Condenser Partition Assembly	X	X	X	X	X	X	X	X	X
45	509-157	Lower Back Assembly	X	X	X	X	X	X	X	X	X
46	113-268	Manifold Bracket	X	X	X	X	X	X	X	X	X
47	113-140	Bottom Support Bracket	X	X	X	X	X	X	X	X	X
48	S133-163	Circuit Breaker Inner Door	X	X	X	X	X	X			
48	S133-205	Toggle Disconnect Inner Door							X	X	X
49	S533-162-*	Control Panel Cover Assembly	X	X	X	X	X	X	X	X	X
50	S153-328-*	Disconnect Access Door	X	X	X	X	X	X	X	X	X
51	134-193	Conduit Access Panel	X	X	X	X	X	X	X	X	X
52	156-029	Conduit Entrance Plate	X	X	X	X	X	X	X	X	X
53	553-388-*	Upper Door Assembly	X	X	X	X	X	X	X	X	X

* Exterior cabinet parts are manufactured with various paint color options. To ensure that you receive the proper paint color, you must include the complete model and serial number of the unit for which cabinet parts are being ordered.

Refer to drawing on Page 2

CABINET COMPONENTS

Drawing No.	Part No.	Description	W60G2DAXB	W60G2DAXC	W60G2DAXD	W60G2DBXB	W60G2DBXC	W60G2DBXD	W60G2DCXB	W60G2DCXC	W60G2DCXD
1	501-570-*	Right Side Assembly	X	X	X	X	X	X	X	X	X
2	S153-326-*	Vestibule Service Door	X	X	X	X	X	X	X	X	X
3	105X1073	Right Evaporator Support Angle	X	X	X	X	X	X	X	X	X
4	541-266	Right Drain Pan Support Assembly	X	X	X	X	X	X	X	X	X
5	S523-123	Drain Pan Assembly	X	X	X	X	X	X	X	X	X
6	105-1080	Evaporator Coil Fill Angle	X	X	X	X	X	X	X	X	X
7	509-156	Upper Back	X	X	X	X	X	X	X	X	X
8	111-063	Supply Air Frame	2	2	2	2	2	2	2	2	2
9	103-439	Heat Exchanger Support Offset	X	X	X	X	X	X	X	X	X
10	Heat Exch Assy	See Burner Components Diagram									
11	105-1066	Top Heat Exchanger Deflector	X	X	X	X	X	X	X	X	X
12	135-216	Inner Air Baffle	X	X	X	X	X	X	X	X	X
13	165-563-*	Top Rain Channel	X	X	X	X	X	X	X	X	X
14	507-246-*	Top Assembly	X	X	X	X	X	X	X	X	X
15	135-184	Right Heat Exchanger Deflector	X	X	X	X	X	X	X	X	X
16	105Y1073	Left Evaporator Support Angle	X	X	X	X	X	X	X	X	X
17	105-1076	Lower Heat Exchanger Deflector	X	X	X	X	X	X	X	X	X
18	501-571-*	Left Side Assembly	X	X	X	X	X	X	X	X	X
19	543-070-*	Left Access Cover	X	X	X	X	X	X	X	X	X
20	105-1070	Left Support Angle	X	X	X	X	X	X	X	X	X
21	S121-484	Blower Partition	X	X	X	X	X	X	X	X	X
22	S900-249	Complete Blower Assembly - 230V	X	X	X	X	X				
22	S900-277	Complete Blower Assembly - 460V						X	X	X	
23	131-163	Filter Tray	X	X	X	X	X	X	X	X	X
24	1921-051	Vent Terminal Gasket	X	X	X	X	X	X	X	X	X
25	118-084-*	Side Grille	2	2	2	2	2	2	2	2	2
Continued on Page 8											

* Exterior cabinet parts are manufactured with various paint color options. To ensure that you receive the proper paint color, you must include the complete model and serial number of the unit for which cabinet parts are being ordered.

Refer to drawing on Page 2

CABINET COMPONENTS

Drawing No.	Part No.	Description	W60G2DAXB	W60G2DAXC	W60G2DAXD	W60G2DBXB	W60G2DBXC	W60G2DBXD	W60G2DCXB	W60G2DCXC	W60G2DCXD
Continued from Page 7											
27	S553-562-*	Filter Access Panel Assembly	X	X	X	X	X	X	X	X	X
28	S553-561-*	Front Door Assembly	X	X	X	X	X	X	X	X	X
29	553-327-*	Vent Option Door Assembly	X	X	X	X	X	X	X	X	X
30	169-119	Outer Vent Hood	X	X	X	X	X	X	X	X	X
31	169-120	Inner Vent Hood	X	X	X	X	X	X	X	X	X
32	WGBFAD-5	Barometric Fresh Air Damper	X	X	X	X	X	X	X	X	X
33	118-048-*	Condenser Grille	X	X	X	X	X	X	X	X	X
34	549-131-*	Right Front Corner Assembly	X	X	X	X	X	X	X	X	X
35	S135-181-*	Air Intake Hood	X	X	X	X	X	X	X	X	X
36	S134-182-*	Air Intake Back	X	X	X	X	X	X	X	X	X
37	125-024	Fan Shroud	X	X	X	X	X	X	X	X	X
38	542-136	Condenser Partition Blank Off Plate	2	2	2	2	2	2	2	2	2
39	541-398	Heat Exchanger Support Assembly	X	X	X	X	X	X	X	X	X
40	142-071	Filter Blank Off Plate	X	X	X	X	X	X	X	X	X
41	127-302	Lower Base	X	X	X	X	X	X	X	X	X
42	103-438	Lower Base Offset	3	3	3	3	3	3	3	3	3
43	S902-1490	Control Panel Assembly	X	X	X						
43	S902-1491	Control Panel Assembly				X	X	X			
43	S902-1489	Control Panel Assembly							X	X	X
44	521-447	Condenser Partition Assembly	X	X	X	X	X	X	X	X	X
45	509-157	Lower Back Assembly	X	X	X	X	X	X	X	X	X
46	113-268	Manifold Bracket	X	X	X	X	X	X	X	X	X
47	113-140	Bottom Support Bracket	X	X	X	X	X	X	X	X	X
48	S133-163	Circuit Breaker Inner Door	X	X	X	X	X	X			
48	S133-205	Toggle Disconnect Inner Door							X	X	X
49	S533-162-*	Control Panel Cover Assembly	X	X	X	X	X	X	X	X	X
50	S153-328-*	Disconnect Access Door	X	X	X	X	X	X	X	X	X
51	156-029	Conduit Entrance Plate	X	X	X	X	X	X	X	X	X
52	134-193	Conduit Access Panel	X	X	X	X	X	X	X	X	X
53	553-388-*	Upper Door Assembly	X	X	X	X	X	X	X	X	X

* Exterior cabinet parts are manufactured with various paint color options. To ensure that you receive the proper paint color, you must include the complete model and serial number of the unit for which cabinet parts are being ordered.

Refer to drawing on Page 2

This page intentionally left blank.

FUNCTIONAL COMPONENTS

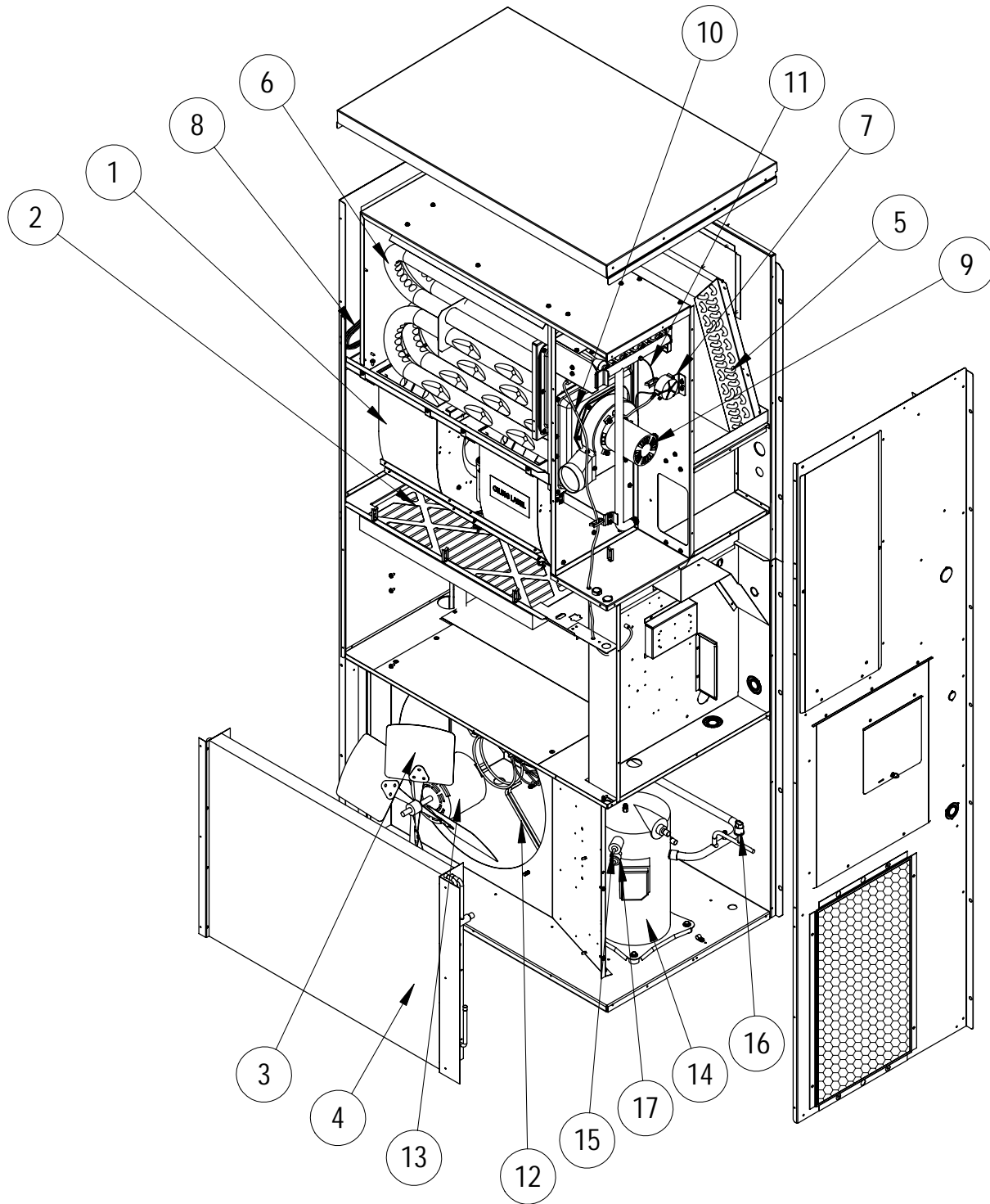

SEXP-677

This drawing to be used for reference for Pages 11, 12 and 13.

FUNCTIONAL COMPONENTS

Drawing No.	Part No.	Description	W42G2DAXB	W42G2DAXC	W42G2DAXD	W42G2DBXB	W42G2DBXC	W42G2DBXD	W42G2DCXB	W42G2DCXC	W42G2DCXD
1	S900-249	Complete Blower Assembly 230/208	X	X	X	X	X	X			
1	S900-277	Complete Blower Assembly 460V							X	X	X
2	7004-027	20 x 30 x 2 Pleated Filter (Standard)	X	X	X	X	X	X	X	X	X
2	7003-030	20 x 30 x 1 AF Filter (Optional)	X	X	X	X	X	X	X	X	X
3	5151-027	Fan Blade	X	X	X	X	X	X	X	X	X
4	5051-078BX	Coil	X	X	X	X	X	X	X	X	X
5	5060-106BX	Coil	X	X	X	X	X	X	X	X	X
6	Heat Exch.	See Burner Components Diagram	X	X	X	X	X	X	X	X	X
7	8406-103	.55" ± .05" Pressure Switch	X	X	X	X	X	X	X	X	X
8	5625-043	Drain Back Orifice	X	X	X	X	X	X	X	X	X
9	8109-014	Induced Draft Blower 230V w/Transition	X	X	X	X	X	X			
9	8109-015	Induced Draft Blower 460V w/Transition							X	X	X
10	8600-011	Suppression Ignition Cable	X	X	X	X	X	X	X	X	X
11	3000-1121	Wire Assembly	X	X	X	X	X	X			
11	3000-1124	Wire Assembly							X	X	X
12	8200-004	Fan Motor Mount	X	X	X	X	X	X	X	X	X
13	8105-039	Motor 230/208V	X	X	X	X	X	X			
13	8105-030	Motor 460V							X	X	X
14	8000-318	Compressor ZP39K5E-PFV	X	X	X						
14	8000-319	Compressor ZP39K5E-TF5				X	X	X			
14	8000-320	Compressor ZP39K5E-TFD							X	X	X
15	1804-0385	High Pressure Switch (Flare)	X	X	X	X	X	X	X	X	X
16	1804-0386	Low Pressure Switch (Flare)	X	X	X	X	X	X	X	X	X
17	CMA-28	Low Ambient Control (Opt.)	X	X	X	X	X	X	X	X	X
NS	8408-038	Freeze Thermostat	X	X	X	X	X	X	X	X	X
NS	5625-008	Distributor	X	X	X	X	X	X	X	X	X
NS	5651-207	Expansion Valve	X	X	X	X	X	X	X	X	X
NS	5651-146	Check Valve	X	X	X	X	X	X	X	X	X
NS	5650-044	Molded Plug	X	X	X	X	X	X	X	X	X
NS	5650-045	Three Way Valve with Solenoid	X	X	X	X	X	X	X	X	X
NS	5051-102BX	Reheat Coil	X	X	X	X	X	X	X	X	X
NS	5201-018	Filter Drier	X	X	X	X	X	X	X	X	X
NS	5650-046	Solenoid Coil 24V	X	X	X	X	X	X	X	X	X
NS	S400-0183	Orifice Parts Bag 3 Tube 75K	X			X			X		
NS	S400-0184	Orifice Parts Bag 4 Tube 100K		X			X			X	
NS	S400-0185	Orifice Parts Bag 5 Tube 125K			X			X			X

NS = Not Shown

FUNCTIONAL COMPONENTS

Drawing No.	Part No.	Description	W48G2DAXB	W48G2DAXC	W48G2DAXD	W48G2DBXB	W48G2DBXC	W48G2DBXD	W48G2DCXB	W48G2DCXC	W48G2DCXD
1	S900-249	Complete Blower Assembly 230/208	X	X	X	X	X	X			
1	S900-277	Complete Blower Assembly 460V							X	X	X
2	7004-027	20 x 30 x 2 Pleated Filter (Standard)	X	X	X	X	X	X	X	X	X
2	7003-030	20 x 30 x 1 AF Filter (Optional)	X	X	X	X	X	X	X	X	X
3	5151-027	Fan Blade	X	X	X	X	X	X	X	X	X
4	5051-083BX	Coil	X	X	X	X	X	X	X	X	X
5	5060-106BX	Coil	X	X	X	X	X	X	X	X	X
6	Heat Exch.	See Burner Components Diagram	X	X	X	X	X	X	X	X	X
7	8406-103	.55" ± .05" Pressure Switch	X	X	X	X	X	X	X	X	X
8	5625-043	Drain Back Orifice	X	X	X	X	X	X	X	X	X
9	8109-014	Induced Draft Blower 230V w/Transition	X	X	X	X	X	X			
9	8109-015	Induced Draft Blower 460V w/Transition							X	X	X
10	8600-011	Suppression Ignition Cable	X	X	X	X	X	X	X	X	X
11	3000-1121	Wire Assembly	X	X	X	X	X	X			
11	3000-1124	Wire Assembly							X	X	X
12	8200-004	Fan Motor Mount	X	X	X	X	X	X	X	X	X
13	8105-039	Motor 230/208V	X	X	X	X	X	X			
13	8105-030	Motor 460V							X	X	X
14	8000-343	Compressor ZP44K5E-PFV	X	X	X						
14	8000-344	Compressor ZP44K5E-TF5				X	X	X			
14	8000-345	Compressor ZP44K5E-TFD							X	X	X
15	1804-0385	High Pressure Switch (Flare)	X	X	X	X	X	X	X	X	X
16	1804-0386	Low Pressure Switch (Flare)	X	X	X	X	X	X	X	X	X
17	CMA-28	Low Ambient Control (Opt.)	X	X	X	X	X	X	X	X	X
NS	8408-038	Freeze Thermostat	X	X	X	X	X	X	X	X	X
NS	5625-008	Distributor	X	X	X	X	X	X	X	X	X
NS	5651-207	Expansion Valve	X	X	X	X	X	X	X	X	X
NS	5651-146	Check Valve	X	X	X	X	X	X	X	X	X
NS	5650-044	Molded Plug	X	X	X	X	X	X	X	X	X
NS	5650-045	Three Way Valve with Solenoid	X	X	X	X	X	X	X	X	X
NS	5051-102BX	Reheat Coil	X	X	X	X	X	X	X	X	X
NS	5201-018	Filter Drier	X	X	X	X	X	X	X	X	X
NS	5650-046	Solenoid Coil 24V	X	X	X	X	X	X	X	X	X
NS	S400-0183	Orifice Parts Bag 3 Tube 75K	X			X			X		
NS	S400-0184	Orifice Parts Bag 4 Tube 100K		X			X			X	
NS	S400-0185	Orifice Parts Bag 5 Tube 125K			X			X			X

NS = Not Shown

Refer to drawing on Page 10

FUNCTIONAL COMPONENTS

Drawing No.	Part No.	Description	W60G2DAXB	W60G2DAXC	W60G2DAXD	W60G2DBXB	W60G2DBXC	W60G2DBXD	W60G2DCXB	W60G2DCXC	W60G2DCXD
1	S900-249	Complete Blower Assembly 230/208	X	X	X	X	X	X			
1	S900-277	Complete Blower Assembly 460V							X	X	X
2	7004-027	20 x 30 x 2 Pleated Filter (Standard)	X	X	X	X	X	X	X	X	X
2	7003-030	20 x 30 x 1 AF Filter (Optional)	X	X	X	X	X	X	X	X	X
3	5151-027	Fan Blade	X	X	X	X	X	X	X	X	X
4	5051-083BX	Coil	X	X	X	X	X	X	X	X	X
5	5060-105BX	Coil	X	X	X	X	X	X	X	X	X
6	Heat Exch.	See Burner Components Diagram	X	X	X	X	X	X	X	X	X
7	8406-103	.55" ± .05" Pressure Switch	X	X	X	X	X	X	X	X	X
8	5625-043	Drain Back Orifice	X	X	X	X	X	X	X	X	X
9	8109-014	Induced Draft Blower 230V w/Transition	X	X	X	X	X	X			
9	8109-015	Induced Draft Blower 460V w/Transition							X	X	X
10	8600-011	Suppression Ignition Cable	X	X	X	X	X	X	X	X	X
11	3000-1121	Wire Assembly	X	X	X	X	X	X			
11	3000-1124	Wire Assembly							X	X	X
12	8200-004	Fan Motor Mount	X	X	X	X	X	X	X	X	X
13	8105-039	Motor 230/208V	X	X	X	X	X	X			
13	8105-030	Motor 460V							X	X	X
14	8000-324	Compressor ZP54K5E-PFV	X	X	X						
14	8000-325	Compressor ZP54K5E-TF5				X	X	X			
14	8000-326	Compressor ZP54K5E-TFD							X	X	X
15	1804-0385	High Pressure Switch (Flare)	X	X	X	X	X	X	X	X	X
16	1804-0386	Low Pressure Switch (Flare)	X	X	X	X	X	X	X	X	X
17	CMA-28	Low Ambient Control (Opt.)	X	X	X	X	X	X	X	X	X
NS	8408-038	Freeze Thermostat	X	X	X	X	X	X	X	X	X
NS	5625-036	Distributor	X	X	X	X	X	X	X	X	X
NS	5651-208	Expansion Valve	X	X	X	X	X	X	X	X	X
NS	5651-146	Check Valve	X	X	X	X	X	X	X	X	X
NS	5650-044	Molded Plug	X	X	X	X	X	X	X	X	X
NS	5650-045	Three Way Valve with Solenoid	X	X	X	X	X	X	X	X	X
NS	5051-102BX	Reheat Coil	X	X	X	X	X	X	X	X	X
NS	5201-018	Filter Drier	X	X	X	X	X	X	X	X	X
NS	5650-046	Solenoid Coil 24V	X	X	X	X	X	X	X	X	X
NS	S400-0183	Orifice Parts Bag 3 Tube 75K	X			X			X		
NS	S400-0184	Orifice Parts Bag 4 Tube 100K		X			X			X	
NS	S400-0185	Orifice Parts Bag 5 Tube 125K			X			X			X

NS = Not Shown

BURNER COMPONENTS

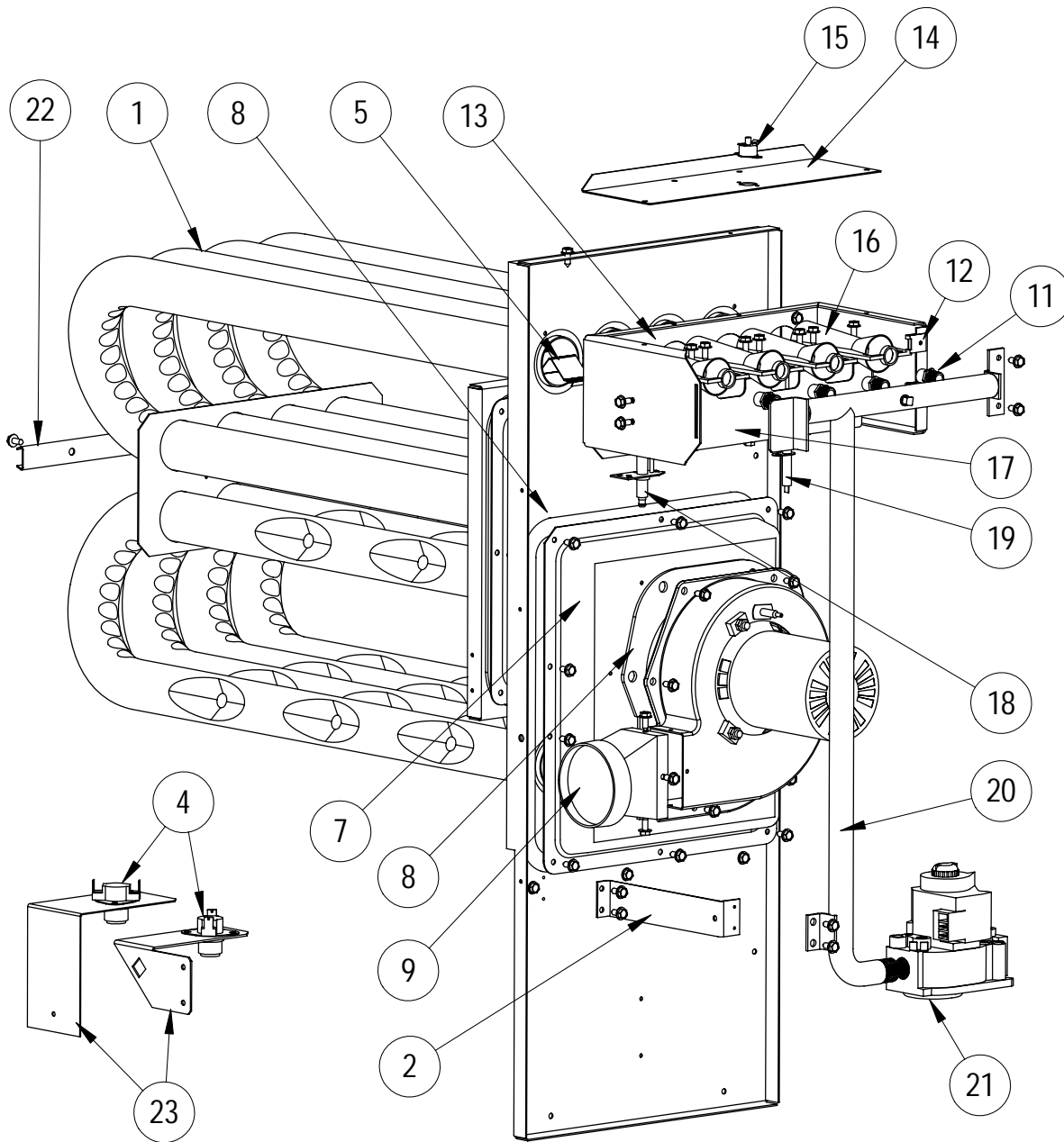

SEXP-678

This drawing to be used for reference for Pages 15, 16 and 17.

BURNER COMPONENTS

Drawing No.	Part No.	Description	W42G2D*XB	W42G2D*NB	W42G2D*XC	W42G2D*NC	W42G2D*XD	W42G2D*ND
1	S171-315	Heat Exchanger Assembly 75K	X	X				
1	S171-317	Heat Exchanger Assembly 100K			X	X		
1	S171-319	Heat Exchanger Assembly 125K					X	X
2	113-268	Manifold Bracket	X	X	X	X	X	X
4	8402-180	Limit Control L140-30	X	X				
4	8402-178	Limit Control L120-30			X	X		
4	8402-177	Limit Control L115-30					X	X
5	9010-083	NOx Screen		3		4		5
6	1921-025-4600	46" Glas-Tak Tape	X	X	X	X	X	X
7	168-126	Collector Box	X	X				
7	168-127	Collector Box			X	X		
7	168-128	Collector Box					X	X
8	1921-044	Gasket Set	X	X	X	X	X	X
9	5809-013	3" Cast Inducer Transition	X	X	X	X	X	X
10	5809-017	3.031" x 4.625" Transition	X	X	X	X	X	X
11	9010-079	Orifice 2.40mm (.0960 diameter)	3	3	4	4	5	5
11	9010-082	Orifice 2.30mm (10% derate)	3	3	4	4	5	5
12	1012-314	U Clip Fastener	4	4	4	4	4	4
13	163-042	Burner Box	X	X				
13	163-044	Burner Box			X	X		
13	163-046	Burner Box					X	X
14	141-268	Flame Rollout Support	X	X				
14	141-269	Flame Rollout Support			X	X		
14	141-270	Flame Rollout Support					X	X
15	8402-124	Flame Rollout Switch L270	X	X	X	X	X	X
16	9010-078	In-Shot Burner 2.5 x 4.5	3	3	4	4	5	5
17	163-041	Burner Support	X	X				
17	163-043	Burner Support			X	X		
17	163-045	Burner Support					X	X
18	8554-024	DSI Spark Igniter	X	X	X	X	X	X
19	8554-025	Flame Sensor	X	X	X	X	X	X
20	5818-054	3-Hole Gas Manifold - 1/2"	X	X				
20	5818-055	4-Hole Gas Manifold - 1/2"			X	X		
20	5818-056	5-Hole Gas Manifold - 1/2"					X	X
21	5651-160	Natural Gas Valve 1/2 x 1/2	X	X	X	X	X	X
22	168-140	Tube Brace 2 Burner	X	X				
22	168-135	Tube Brace 3 Burner			X	X		
22	168-134	Tube Brace 4 Burner					X	X
23	112-355	Limit Bracket	X	X				
23	112-475	Limit Bracket			X	X	X	X

Refer to drawing on Page 14

BURNER COMPONENTS

Drawing No.	Part No.	Description	W48G2D*XB	W48G2D*NB	W48G2D*XC	W48G2D*NC	W48G2D*XD	W48G2D*ND
1	S171-315	Heat Exchanger Assembly 75K	X	X				
1	S171-317	Heat Exchanger Assembly 100K			X	X		
1	S171-319	Heat Exchanger Assembly 125K					X	X
2	113-268	Manifold Bracket	X	X	X	X	X	X
4	8402-180	Limit Control L140-30	X	X				
4	8402-178	Limit Control L120-30			X	X		
4	8402-177	Limit Control L115-30					X	X
5	9010-083	NOx Screen		3		4		5
6	1921-025-4600	46" Glas-Tak Tape	X	X	X	X	X	X
7	168-126	Collector Box	X	X				
7	168-127	Collector Box			X	X		
7	168-128	Collector Box					X	X
8	1921-044	Gasket Set	X	X	X	X	X	X
9	5809-013	3" Cast Inducer Transition	X	X	X	X	X	X
10	5809-017	3.031" x 4.625" Transition	X	X	X	X	X	X
11	9010-079	Orifice 2.40mm (.0960 diameter)	3	3	4	4	5	5
11	9010-082	Orifice 2.30mm (10% derate)	3	3	4	4	5	5
12	1012-314	U Clip Fastener	4	4	4	4	4	4
13	163-042	Burner Box	X	X				
13	163-044	Burner Box			X	X		
13	163-046	Burner Box					X	X
14	141-268	Flame Rollout Support	X	X				
14	141-269	Flame Rollout Support			X	X		
14	141-270	Flame Rollout Support					X	X
15	8402-124	Flame Rollout Switch L270	X	X	X	X	X	X
16	9010-078	In-Shot Burner 2.5 x 4.5	3	3	4	4	5	5
17	163-041	Burner Support	X	X				
17	163-043	Burner Support			X	X		
17	163-045	Burner Support					X	X
18	8554-024	DSI Spark Igniter	X	X	X	X	X	X
19	8554-025	Flame Sensor	X	X	X	X	X	X
20	5818-054	3-Hole Gas Manifold - 1/2"	X	X				
20	5818-055	4-Hole Gas Manifold - 1/2"			X	X		
20	5818-056	5-Hole Gas Manifold - 1/2"					X	X
21	5651-160	Natural Gas Valve 1/2 x 1/2	X	X	X	X	X	X
22	168-140	Tube Brace 2 Burner	X	X				
22	168-135	Tube Brace 3 Burner			X	X		
22	168-134	Tube Brace 4 Burner					X	X
23	112-355	Limit Bracket	X	X				
23	112-475	Limit Bracket			X	X	X	X

Refer to drawing on Page 14

BURNER COMPONENTS

Drawing No.	Part No.	Description	W60G2D*XB	W60G2D*NB	W60G2D*XC	W60G2D*NC	W60G2D*XD	W60G2D*ND
1	S171-315	Heat Exchanger Assembly 75K	X	X				
1	S171-317	Heat Exchanger Assembly 100K			X	X		
1	S171-319	Heat Exchanger Assembly 125K					X	X
2	113-268	Manifold Bracket	X	X	X	X	X	X
4	8402-180	Limit Control L140-30	X	X				
4	8402-178	Limit Control L120-30			X	X		
4	8402-177	Limit Control L115-30					X	X
5	9010-083	NOx Screen		3		4		5
6	1921-025-4600	46" Glas-Tak Tape	X	X	X	X	X	X
7	168-126	Collector Box	X	X				
7	168-127	Collector Box			X	X		
7	168-128	Collector Box					X	X
8	1921-044	Gasket Set	X	X	X	X	X	X
9	5809-013	3" Cast Inducer Transition	X	X	X	X	X	X
10	5809-017	3.031" x 4.625" Transition	X	X	X	X	X	X
11	9010-079	Orifice 2.40mm (.0960 diameter)	3	3	4	4	5	5
11	9010-082	Orifice 2.30mm (10% derate)	3	3	4	4	5	5
12	1012-314	U Clip Fastener	4	4	4	4	4	4
13	163-042	Burner Box	X	X				
13	163-044	Burner Box			X	X		
13	163-046	Burner Box					X	X
14	141-268	Flame Rollout Support	X	X				
14	141-269	Flame Rollout Support			X	X		
14	141-270	Flame Rollout Support					X	X
15	8402-124	Flame Rollout Switch L270	X	X	X	X	X	X
16	9010-078	In-Shot Burner 2.5 x 4.5	3	3	4	4	5	5
17	163-041	Burner Support	X	X				
17	163-043	Burner Support			X	X		
17	163-045	Burner Support					X	X
18	8554-024	DSI Spark Igniter	X	X	X	X	X	X
19	8554-025	Flame Sensor	X	X	X	X	X	X
20	5818-054	3-Hole Gas Manifold - 1/2"	X	X				
20	5818-055	4-Hole Gas Manifold - 1/2"			X	X		
20	5818-056	5-Hole Gas Manifold - 1/2"					X	X
21	5651-160	Natural Gas Valve 1/2 x 1/2	X	X	X	X	X	X
22	168-140	Tube Brace 2 Burner	X	X				
22	168-135	Tube Brace 3 Burner			X	X		
22	168-134	Tube Brace 4 Burner					X	X
23	112-355	Limit Bracket	X	X				
23	112-475	Limit Bracket			X	X	X	X

Refer to drawing on Page 14

CONTROL PANEL

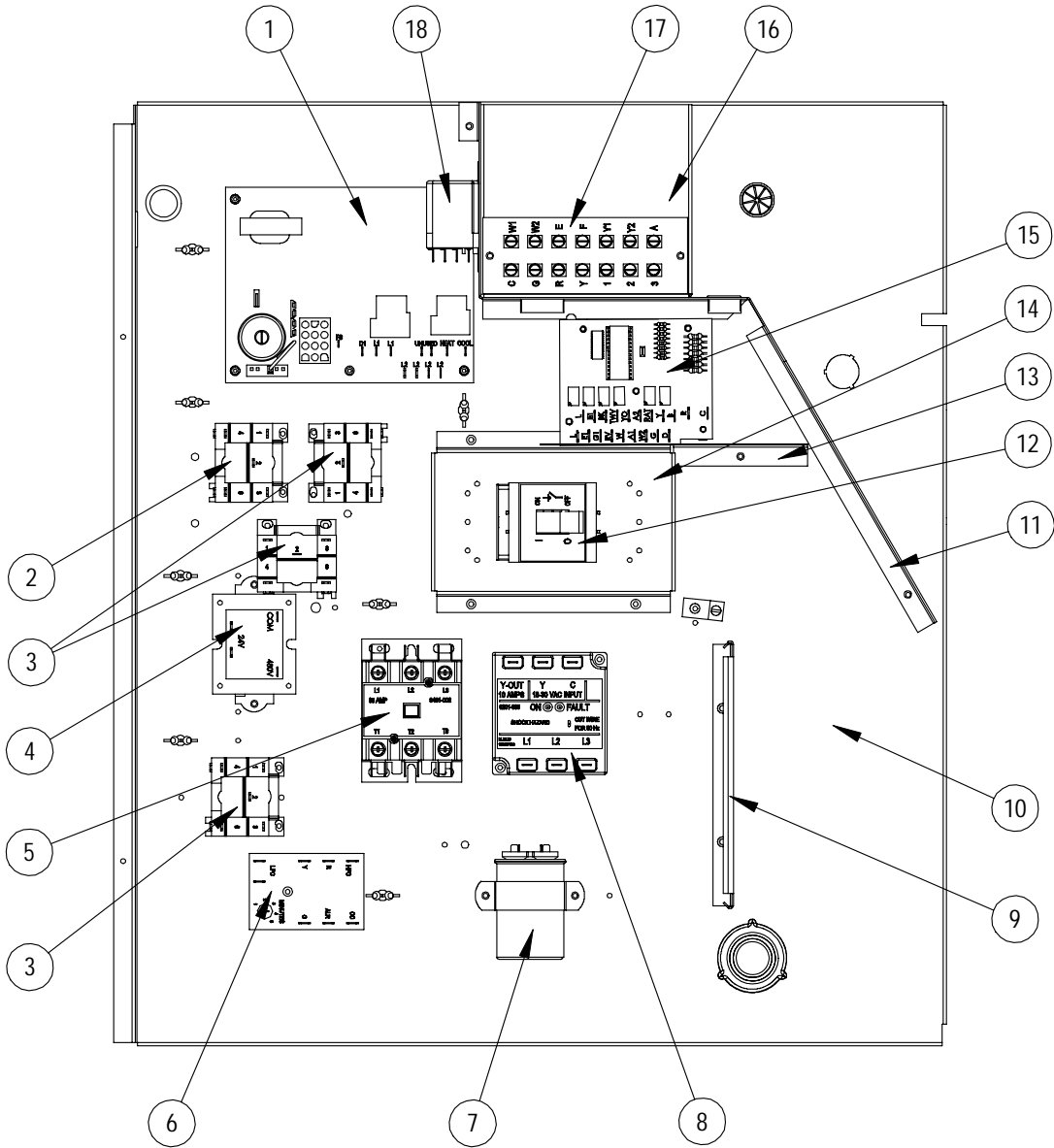

SEXP-567

CABINET COMPONENTS

Dwg. No.	Part No.	Description	W42G2DA	W42G2DB	W42G2DC	W48G2DA	W48G2DB	W48G2DC	W60G2DA	W60G2DB	W60G2DC
1	5651-159	Integrated Furnace Control	X	X	X	X	X	X	X	X	X
2	8201-086	460 Volt Relay DPDT			X			X			X
3	8201-032	460 Volt Relay SPDT			3			3			3
4	8407-035	Transformer 50 VA 208/240 - 24V	X	X		X	X		X	X	
4	8407-042	Transformer 50 VA 480 - 24V			X			X			X
5	8401-025	Contacto 2-Pole 40 Amp	X	X		X	X		X	X	
5	8401-002	Contacto 3-Pole 25 Amp			X			X			X
6	8201-088	Compressor Control Module	X	X	X	X	X	X	X	X	X
7	8552-005	Capacitor 10MFD 370 V 1-1/4" Oval		X			X			X	
7	8552-026	Capacitor 15MFD 370 V 1-3/4" Round			X			X			X
7	8552-079	Capacitor 45+10MFD 370 V 2-1/2" Round	X								
7	8552-089	Capacitor 70+10MFD 370 V 2-1/2" Round				X					
7	8552-058	Capacitor 80+10MFD 370 V 2-1/2" Round							X		
8	8201-085	Phase Monitor		X	X		X	X		X	X
9	135-130	Wire Shield	X	X	X	X	X	X	X	X	X
10	517-276	Control Panel Assembly	X	X	X	X	X	X	X	X	X
11	117-248	Low Voltage Partition	X	X	X	X	X	X	X	X	X
12	8615-040	Circuit Breaker 50A, 2 Pole	X			X					
12	8615-042	Circuit Breaker 35A, 3 Pole		X			X				
12	8615-067	460V 40A Toggle Disconnect			X			X			X
12	8615-069	Switch Cover Plate			X			X			X
12	8615-041	Circuit Breaker 60A, 2 Pole							X		
12	8615-043	Circuit Breaker 40A, 3 Pole								X	
13	135-266	High Voltage Barrier			X			X			X
14	113-269	Circuit Breaker Mounting Base	X	X		X	X		X	X	
14	113-393	Toggle Disconnect Base			X			X			X
15	8201-113	Dehumidification Logic Control Board	X	X	X	X	X	X	X	X	X
16	117-247	Low Voltage Box	X	X	X	X	X	X	X	X	X
17	8607-024	Low Voltage Terminal Strip	X	X	X	X	X	X	X	X	X
18	8201-048	Relay DPDT	X	X	X	X	X	X	X	X	X
NS	4085A167	Wiring Diagram	X								
NS	4085A265	Wiring Diagram		X							
NS	4085A388	Wiring Diagram			X						
NS	4085A169	Wiring Diagram				X			X		
NS	4085A267	Wiring Diagram					X			X	
NS	4085A390	Wiring Diagram						X			X

NS – Not Shown

BLOWER ASSEMBLY

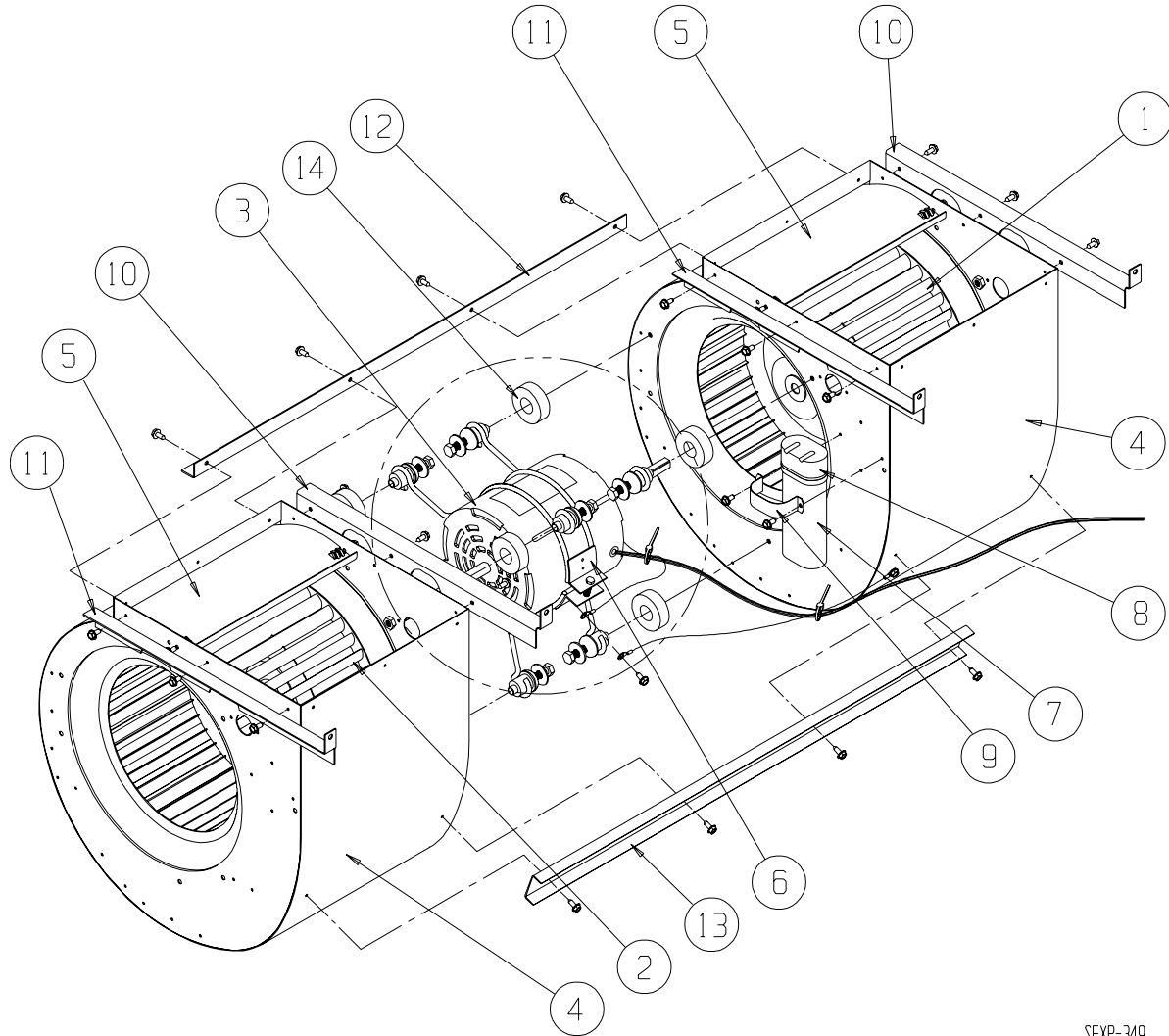

SEXP-349

Drawing No.	Part No.	Description	S900-249	S900-277
1	5152-011	Blower Wheel 10-8	X	X
2	5152-012	Blower Wheel 10-8	X	X
3	8106-038	Motor 230/208 V	X	
3	8620-209	Motor 460V		X
4	151-101	Blower Housing	2	2
5	144-166	Diffuser	2	2
6	8200-040	Motor Mount	X	X
7	8552-005	Capacitor 10 MFD 370V	X	X
8	8611-002	Capacitor Boot	X	X
9	8550-003	Capacitor Bracket	X	X
10	105X1075	Angle – Right	2	2
11	105Y1075	Angle – Left	2	2
12	105-881	Angle – Back	X	X
13	165-564	Channel – Front	X	X
14	5451-011	Grommets	3	3