REPLACEMENT PARTS MANUAL

WALL MOUNTED GAS/ELECTRIC

Models:

W24G3DA W30G3DA W36G3DA
W24G3DB W30G3DB W36G3DB
W24G3DC W30G3DC W36G3DC

Contents

Description	Page	Description	Page
Cabinet Components		Blower Assembly	
♦ Exploded View	2	♦ Exploded View	20
♦ Usage List	3	♦ Usage List	20
♦ Usage List	4		
♦ Usage List	5		
♦ Usage List	6		
♦ Usage List	7		
♦ Usage List	8		
Functional Components			
♦ Exploded View	10		
♦ Usage List	11		
♦ Usage List	12		
♦ Usage List	13		
Burner Components			
♦ Exploded View	14		
♦ Usage List	15		
♦ Usage List	16		
♦ Usage List	17		
Control Panel			
♦ Exploded View	18		
♦ Usage List	19		

General Notes

- Revised and/or additional pages may be issued from time to time.
- A complete and current manual consists of pages shown in the following contents section.

Important

- Contact the installing and/or local Bard distributor for all parts requirements. Make sure you have the complete model and serial number available from the unit rating plates.



Bard Manufacturing Company, Inc.
Bryan, Ohio 43506
www.bardhvac.com

Manual: 2110-819
Supersedes: **NEW**
Date: 4-1-15

CABINET COMPONENTS

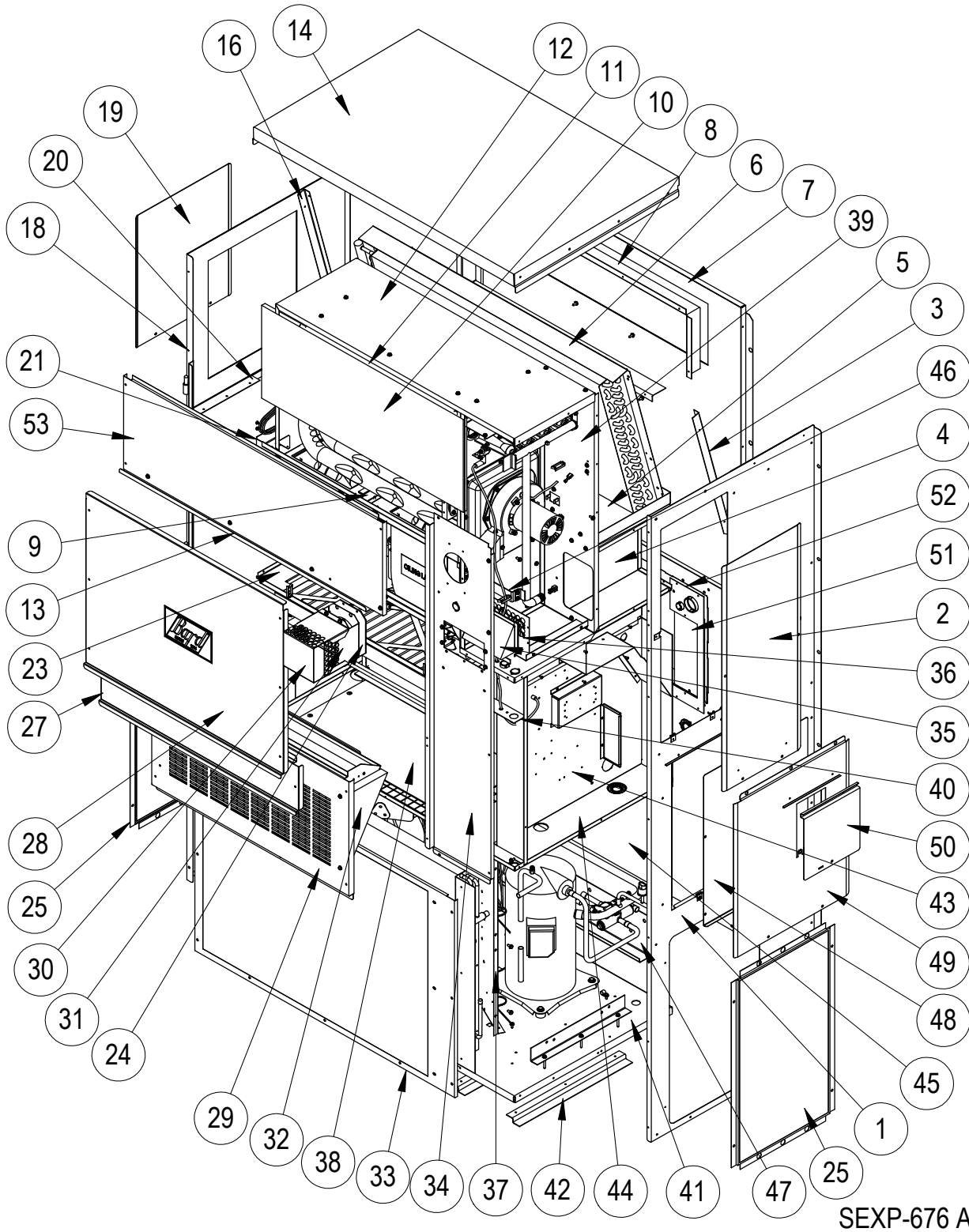

SEXP-676 A

This drawing to be used as reference for pages 3, 4, 5, 6, 7 and 8

CABINET COMPONENTS

Drawing No.	Part No.	Description	W24G3DAXA	W24G3DAXB	W24G3DAXC	W24G3DBXA	W24G3DBXB	W24G3DBXC	W24G3DCXA	W24G3DCXB	W24G3DCXC
1	501-568-*	Right Side Assembly	X	X	X	X	X	X	X	X	X
2	S153-347-*	Vestibule Service Door	X	X	X	X	X	X	X	X	X
3	105X1073	Right Evaporator Support Angle	X	X	X	X	X	X	X	X	X
4	541-285	Right Drain Pan Support Assembly	X	X	X	X	X	X	X	X	X
5	S523-124	Drain Pan Assembly	X	X	X	X	X	X	X	X	X
6	105-1115	Evaporator Coil Fill Angle	X	X	X	X	X	X	X	X	X
7	509-166	Upper Back	X	X	X	X	X	X	X	X	X
8	111-091	Supply Air Frame	2	2	2	2	2	2	2	2	2
9	103-452	Heat Exchanger Support Offset	X	X	X	X	X	X	X	X	X
10	Heat Exch Assy	See Burner Components Diagram									
11	105-1113	Top Heat Exchanger Deflector	X	X	X	X	X	X	X	X	X
12	135-217	Inner Air Baffle	X	X	X	X	X	X	X	X	X
13	165-573-*	Top Rain Channel	X	X	X	X	X	X	X	X	X
14	507-242-*	Top Assembly	X	X	X	X	X	X	X	X	X
16	105Y1073	Left Evaporator Support Angle	X	X	X	X	X	X	X	X	X
17	542-082	Rear Block Off Plate Assembly	X	X	X	X	X	X	X	X	X
18	501-748-*	Left Side Assembly	X	X	X	X	X	X	X	X	X
19	543-070-*	Left Access Cover	X	X	X	X	X	X	X	X	X
20	105-1108	Left Support Angle	X	X	X	X	X	X	X	X	X
21	S121-353	Blower Partition	X	X	X	X	X	X	X	X	X
23	131-341	Filter Tray	X	X	X	X	X	X	X	X	X
24	1921-051	Vent Terminal Gasket	X	X	X	X	X	X	X	X	X
25	118-083-*	Side Grille	2	2	2	2	2	2	2	2	2
<i>Continued on page 4</i>											

* Exterior cabinet parts are manufactured with various paint color options. To ensure the proper paint color is received, include the complete model number and serial number of the unit for which parts are being ordered.

Refer to drawing on page 2

CABINET COMPONENTS

Drawing No.	Part No.	Description	W24G3DAXA	W24G3DAXB	W24G3DAXC	W24G3DBXA	W24G3DBXB	W24G3DBXC	W24G3DCXA	W24G3DCXB	W24G3DCXC
<i>Continued from page 3</i>											
27	553-560-*	Filter Access Panel Assembly	X	X	X	X	X	X	X	X	X
28	S553-559-*	Front Door Assembly	X	X	X	X	X	X	X	X	X
29	553-346-*	Vent Option Door Assembly	X	X	X	X	X	X	X	X	X
30	169-119	Outer Vent Hood	X	X	X	X	X	X	X	X	X
31	169-120	Inner Vent Hood	X	X	X	X	X	X	X	X	X
32	WGBFAD-3	Barometric Fresh Air Damper	X	X	X	X	X	X	X	X	X
33	118-059-*	Condenser Grille	X	X	X	X	X	X	X	X	X
34	549-131-*	Right Front Corner Assembly	X	X	X	X	X	X	X	X	X
35	S135-181-*	Air Intake Hood	X	X	X	X	X	X	X	X	X
36	S134-182-*	Air Intake Back	X	X	X	X	X	X	X	X	X
37	125-022	Fan Shroud	X	X	X	X	X	X	X	X	X
38	542-138	Cond. Block Off Plate Assembly	X	X	X	X	X	X	X	X	X
39	541-402	Heat Exchanger Support Assembly	X	X	X	X	X	X	X	X	X
40	142-080	Filter Blank Off Plate	X	X	X	X	X	X	X	X	X
41	127-318	Lower Base	X	X	X	X	X	X	X	X	X
42	103-449	Lower Base Offset	3	3	3	3	3	3	3	3	3
43	517-276	Control Panel Assembly	X	X	X	X	X	X	X	X	X
44	521-441	Condenser Partition Assembly	X	X	X	X	X	X	X	X	X
45	509-167	Lower Back Assembly	X	X	X	X	X	X	X	X	X
46	113-268	Manifold Bracket	X	X	X	X	X	X	X	X	X
47	113-140	Bottom Support Bracket	X	X	X	X	X	X	X	X	X
48	S133-163	Circuit Breaker Inner Door	X	X	X	X	X				
48	S133-205	Toggle Disconnect Inner Door							X	X	X
49	S533-162-*	Control Panel Cover Assembly	X	X	X	X	X	X	X	X	X
50	S153-328-*	Disconnect Access Door	X	X	X	X	X	X	X	X	X
51	134-199	Conduit Access Panel	X	X	X	X	X	X	X	X	X
52	156-030	Conduit Entrance Plate	X	X	X	X	X	X	X	X	X
53	553-376-*	Upper Door Assembly	X	X	X	X	X	X	X	X	X

* Exterior cabinet parts are manufactured with various paint color options. To ensure the proper paint color is received, include the complete model number and serial number of the unit for which parts are being ordered.

Refer to drawing on page 2

CABINET COMPONENTS

Drawing No.	Part No.	Description	W30G3DAXA	W30G3DAXB	W30G3DAXC	W30G3DBXA	W30G3DBXB	W30G3DBXC	W30G3DCXA	W30G3DCXB	W30G3DCXC
1	501-568-*	Right Side Assembly	X	X	X	X	X	X	X	X	X
2	S153-347-*	Vestibule Service Door	X	X	X	X	X	X	X	X	X
3	105X1073	Right Evaporator Support Angle	X	X	X	X	X	X	X	X	X
4	541-285	Right Drain Pan Support Assembly	X	X	X	X	X	X	X	X	X
5	S523-124	Drain Pan Assembly	X	X	X	X	X	X	X	X	X
6	105-1115	Evaporator Coil Fill Angle	X	X	X	X	X	X	X	X	X
7	509-166	Upper Back	X	X	X	X	X	X	X	X	X
8	111-091	Supply Air Frame	2	2	2	2	2	2	2	2	2
9	103-452	Heat Exchanger Support Offset	X	X	X	X	X	X	X	X	X
10	Heat Exch Assy	See Burner Components Diagram									
11	105-1113	Top Heat Exchanger Deflector	X	X	X	X	X	X	X	X	X
12	135-217	Inner Air Baffle	X	X	X	X	X	X	X	X	X
13	165-573-*	Top Rain Channel	X	X	X	X	X	X	X	X	X
14	507-242-*	Top Assembly	X	X	X	X	X	X	X	X	X
16	105Y1073	Left Evaporator Support Angle	X	X	X	X	X	X	X	X	X
17	542-082	Rear Block Off Plate Assembly	X	X	X	X	X	X	X	X	X
18	501-748-*	Left Side Assembly	X	X	X	X	X	X	X	X	X
19	543-070-*	Left Access Cover	X	X	X	X	X	X	X	X	X
20	105-1108	Left Support Angle	X	X	X	X	X	X	X	X	X
21	S121-353	Blower Partition	X	X	X	X	X	X	X	X	X
23	131-341	Filter Tray	X	X	X	X	X	X	X	X	X
24	1921-051	Vent Terminal Gasket	X	X	X	X	X	X	X	X	X
25	118-083-*	Side Grille	2	2	2	2	2	2	2	2	2

Continued on page 6

* Exterior cabinet parts are manufactured with various paint color options. To ensure the proper paint color is received, include the complete model number and serial number of the unit for which parts are being ordered.

Refer to drawing on page 2

CABINET COMPONENTS

Drawing No.	Part No.	Description	W30G3DAXA	W30G3DAXB	W30G3DAXC	W30G3DBXA	W30G3DBXB	W30G3DBXC	W30G3DCXA	W30G3DCXB	W30G3DCXC
<i>Continued from page 5</i>											
27	553-560-*	Filter Access Panel Assembly	X	X	X	X	X	X	X	X	X
28	S553-559-*	Front Door Assembly	X	X	X	X	X	X	X	X	X
29	553-346-*	Vent Option Door Assembly	X	X	X	X	X	X	X	X	X
30	169-119	Outer Vent Hood	X	X	X	X	X	X	X	X	X
31	169-120	Inner Vent Hood	X	X	X	X	X	X	X	X	X
32	WGBFAD-3	Barometric Fresh Air Damper	X	X	X	X	X	X	X	X	X
33	118-059-*	Condenser Grille	X	X	X	X	X	X	X	X	X
34	549-131-*	Right Front Corner Assembly	X	X	X	X	X	X	X	X	X
35	S135-181-*	Air Intake Hood	X	X	X	X	X	X	X	X	X
36	S134-182-*	Air Intake Back	X	X	X	X	X	X	X	X	X
37	125-022	Fan Shroud	X	X	X	X	X	X	X	X	X
38	542-138	Cond. Block Off Plate Assembly	X	X	X	X	X	X	X	X	X
39	541-402	Heat Exchanger Support Assembly	X	X	X	X	X	X	X	X	X
40	142-080	Filter Blank Off Plate	X	X	X	X	X	X	X	X	X
41	127-318	Lower Base	X	X	X	X	X	X	X	X	X
42	103-449	Lower Base Offset	3	3	3	3	3	3	3	3	3
43	517-276	Control Panel Assembly	X	X	X	X	X	X	X	X	X
44	521-441	Condenser Partition Assembly	X	X	X	X	X	X	X	X	X
45	509-167	Lower Back Assembly	X	X	X	X	X	X	X	X	X
46	113-268	Manifold Bracket	X	X	X	X	X	X	X	X	X
47	113-140	Bottom Support Bracket	X	X	X	X	X	X	X	X	X
48	S133-163	Circuit Breaker Inner Door	X	X	X	X	X				
48	S133-205	Disconnect Inner Door							X	X	X
49	S533-162-*	Control Panel Cover Assembly	X	X	X	X	X	X	X	X	X
50	S153-328-*	Disconnect Access Door	X	X	X	X	X	X	X	X	X
51	134-199	Conduit Access Panel	X	X	X	X	X	X	X	X	X
52	156-030	Conduit Entrance Plate	X	X	X	X	X	X	X	X	X
53	553-376-*	Upper Door Assembly	X	X	X	X	X	X	X	X	X

* Exterior cabinet parts are manufactured with various paint color options. To ensure the proper paint color is received, include the complete model number and serial number of the unit for which parts are being ordered.

Refer to drawing on page 2

CABINET COMPONENTS

Drawing No.	Part No.	Description	W36G3DAXA	W36G3DAXB	W36G3DAXC	W36G3DBXA	W36G3DBXB	W36G3DBXC	W36G3DCXA	W36G3DCXB	W36G3DCXC
1	501-568-*	Right Side Assembly	X	X	X	X	X	X	X	X	X
2	S153-347-*	Vestibule Service Door	X	X	X	X	X	X	X	X	X
3	105X1073	Right Evaporator Support Angle	X	X	X	X	X	X	X	X	X
4	541-285	Right Drain Pan Support Assembly	X	X	X	X	X	X	X	X	X
5	S523-124	Drain Pan Assembly	X	X	X	X	X	X	X	X	X
6	105-1115	Evaporator Coil Fill Angle	X	X	X	X	X	X	X	X	X
7	509-166	Upper Back	X	X	X	X	X	X	X	X	X
8	111-091	Supply Air Frame	2	2	2	2	2	2	2	2	2
9	103-452	Heat Exchanger Support Offset	X	X	X	X	X	X	X	X	X
10	Heat Exch Assy	See Burner Components Diagram									
11	105-1113	Top Heat Exchanger Deflector	X	X	X	X	X	X	X	X	X
12	135-217	Inner Air Baffle	X	X	X	X	X	X	X	X	X
13	165-573-*	Top Rain Channel	X	X	X	X	X	X	X	X	X
14	507-242-*	Top Assembly	X	X	X	X	X	X	X	X	X
16	105Y1073	Left Evaporator Support Angle	X	X	X	X	X	X	X	X	X
17	542-082	Rear Block Off Plate Assembly	X	X	X	X	X	X	X	X	X
18	501-748-*	Left Side Assembly	X	X	X	X	X	X	X	X	X
19	543-070-*	Left Access Cover	X	X	X	X	X	X	X	X	X
20	105-1108	Left Support Angle	X	X	X	X	X	X	X	X	X
21	S121-353	Blower Partition	X	X	X	X	X	X	X	X	X
23	131-341	Filter Tray	X	X	X	X	X	X	X	X	X
24	1921-051	Vent Terminal Gasket	X	X	X	X	X	X	X	X	X
25	118-083-*	Side Grille	2	2	2	2	2	2	2	2	2
<i>Continued on page 8</i>											

* Exterior cabinet parts are manufactured with various paint color options. To ensure the proper paint color is received, include the complete model number and serial number of the unit for which parts are being ordered.

Refer to drawing on page 2

CABINET COMPONENTS

Drawing No.	Part No.	Description	W36G3DAXA	W36G3DAXB	W36G3DAXC	W36G3DBXA	W36G3DBXB	W36G3DBXC	W36G3DCXA	W36G3DCXB	W36G3DCXC
<i>Continued from page 7</i>											
27	553-560*	Filter Access Panel Assembly	X	X	X	X	X	X	X	X	X
28	S553-559-*	Front Door Assembly	X	X	X	X	X	X	X	X	X
29	553-346-*	Vent Option Door Assembly	X	X	X	X	X	X	X	X	X
30	169-119	Outer Vent Hood	X	X	X	X	X	X	X	X	X
31	169-120	Inner Vent Hood	X	X	X	X	X	X	X	X	X
32	WGBFAD-3	Barometric Fresh Air Damper	X	X	X	X	X	X	X	X	X
33	118-059-*	Condenser Grille	X	X	X	X	X	X	X	X	X
34	549-131-*	Right Front Corner Assembly	X	X	X	X	X	X	X	X	X
35	S135-181-*	Air Intake Hood	X	X	X	X	X	X	X	X	X
36	S134-182-*	Air Intake Back	X	X	X	X	X	X	X	X	X
37	125-022	Fan Shroud	X	X	X	X	X	X	X	X	X
38	542-138	Cond. Block Off Plate Assembly	X	X	X	X	X	X	X	X	X
39	541-402	Heat Exchanger Support Assembly	X	X	X	X	X	X	X	X	X
40	142-080	Filter Blank Off Plate	X	X	X	X	X	X	X	X	X
41	127-318	Lower Base	X	X	X	X	X	X	X	X	X
42	103-449	Lower Base Offset	3	3	3	3	3	3	3	3	3
43	517-276	Control Panel Assembly	X	X	X	X	X	X	X	X	X
44	521-441	Condenser Partition Assembly	X	X	X	X	X	X	X	X	X
45	509-167	Lower Back Assembly	X	X	X	X	X	X	X	X	X
46	113-268	Manifold Bracket	X	X	X	X	X	X	X	X	X
47	113-140	Bottom Support Bracket	X	X	X	X	X	X	X	X	X
48	S133-163	Circuit Breaker Inner Door	X	X	X	X	X				
48	S133-205	Disconnect Inner Door							X	X	X
49	S533-162-*	Control Panel Cover Assembly	X	X	X	X	X	X	X	X	X
50	S153-328-*	Disconnect Access Door	X	X	X	X	X	X	X	X	X
51	134-199	Conduit Access Panel	X	X	X	X	X	X	X	X	X
52	156-030	Conduit Entrance Plate	X	X	X	X	X	X	X	X	X
53	553-376-*	Upper Door Assembly	X	X	X	X	X	X	X	X	X

* Exterior cabinet parts are manufactured with various paint color options. To ensure the proper paint color is received, include the complete model number and serial number of the unit for which parts are being ordered.

Refer to drawing on page 2

This page intentionally left blank

FUNCTIONAL COMPONENTS

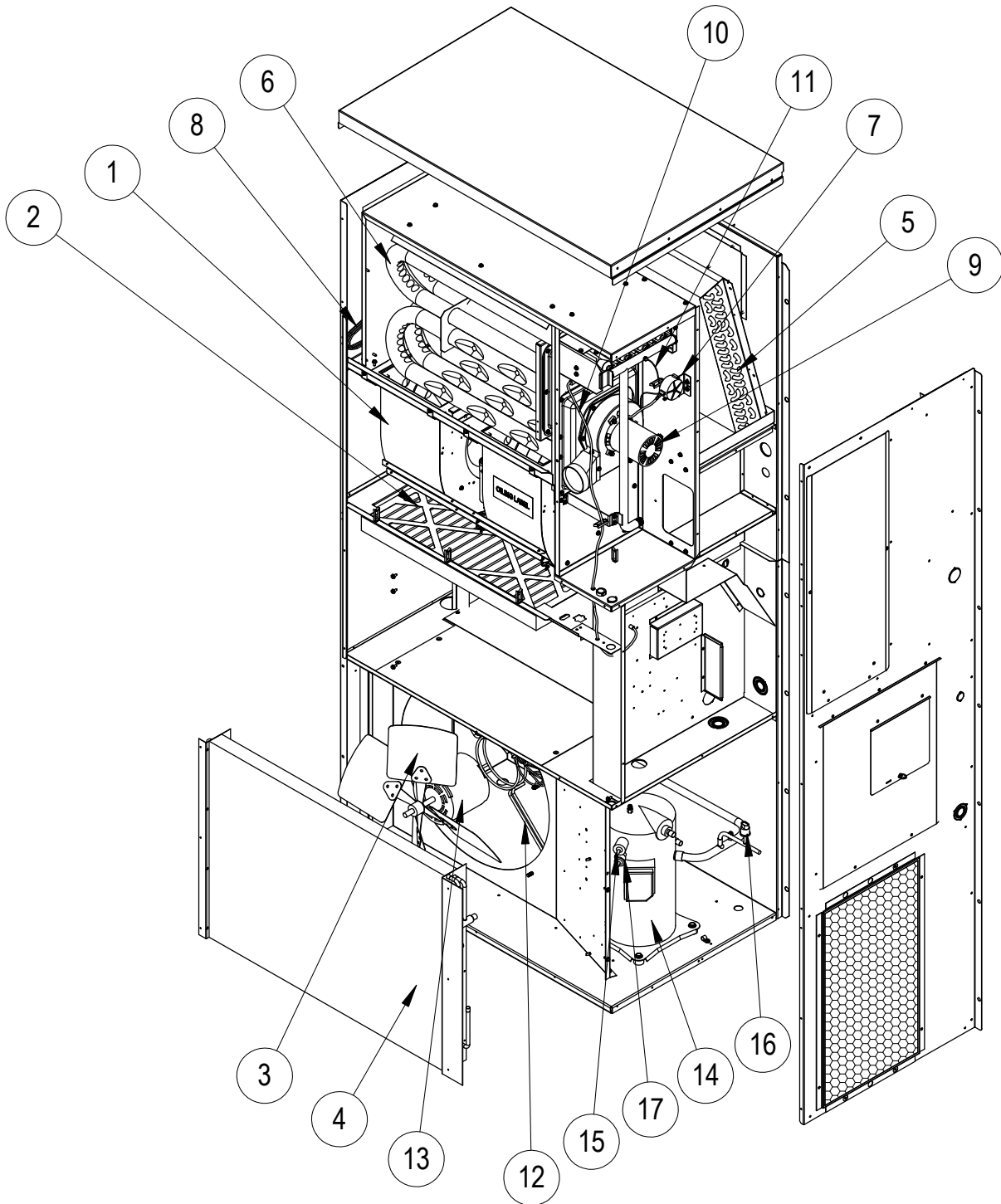

SEXP-677

This drawing to be used for reference for pages 11, 12 and 13

FUNCTIONAL COMPONENTS

Drawing No.	Part No.	Description	W24G3DAXA	W24G3DAXB	W24G3DAXC	W24G3DBXA	W24G3DBXB	W24G3DBXC	W24G3DCXA	W24G3DCXB	W24G3DCXC
1	S900-266	Complete Blower Assembly 230/208	X	X	X	X	X	X			
1	S900-275	Complete Blower Assembly 460V							X	X	X
2	7004-040	20 x 25 x 2 Pleated Filter (Standard)	X	X	X	X	X	X	X	X	X
2	7003-042	20 x 25 x 1 AF Filter (Optional)	X	X	X	X	X	X	X	X	X
3	5151-045	Fan Blade	X	X	X	X	X	X	X	X	X
4	5051-066BX	Standard Outdoor Coil	X	X	X	X	X	X	X	X	X
4	5054-066BX	Coated Outdoor Coil									
			(Optional Coil in Place of Standard)								
5	5060-148BX	Standard Indoor Coil	X	X	X	X	X	X	X	X	X
5	5062-148BX	Coated Indoor Coil									
			(Optional Coil in Place of Standard)								
6	Heat Exch.	See Burner Components Diagram	X	X	X	X	X	X	X	X	X
7	8406-103	.55" + .05" Pressure Switch	X	X	X	X	X	X	X	X	X
9	8109-014	Induced Draft Blower 230V w/Transition	X	X	X	X	X	X			
9	8109-015	Induced Draft Blower 460V w/Transition							X	X	X
10	8600-011	Suppression Ignition Cable	X	X	X	X	X	X	X	X	X
11	3000-1121	Wire Assembly	X	X	X	X	X	X			
11	3000-1124	Wire Assembly							X	X	X
12	8200-001	Fan Motor Mount	X	X	X	X	X	X	X	X	X
13	8103-013	Motor 230/208V	X	X	X	X	X	X			
13	8103-020	Motor 460V							X	X	X
14	8000-314	Compressor ZP24K5E-PFV-130	X	X	X						
14	8000-315	Compressor ZP24K5E-TF5-130				X	X	X			
14	8000-316	Compressor ZP24K5E-TFD-130							X	X	X
15	1804-0462	High Pressure Switch (Flare)	X	X	X	X	X	X	X	X	X
16	1804-0386	Low Pressure Switch (Flare)	X	X	X	X	X	X	X	X	X
17	CMA-28	Low Ambient Control - Opt. - (Flare)	X	X	X	X	X	X	X	X	X
NS	5651-146	Check Valve	X	X	X	X	X	X	X	X	X
NS	5650-044	Molded Plug	X	X	X	X	X	X	X	X	X
NS	5650-045	Three Way Valve with Solenoid	X	X	X	X	X	X	X	X	X
NS	5651-205	Expansion Valve	X	X	X	X	X	X	X	X	X
NS	5051-120BX	Reheat Coil	X	X	X	X	X	X	X	X	X
NS	5054-120BX	Coated Reheat Coil									
			(Optional Coil in Place of Standard)								
NS	5201-017	Filter Drier	X	X	X	X	X	X	X	X	X
NS	8408-038	Freeze Thermostat	X	X	X	X	X	X	X	X	X
NS	5650-046	Solenoid Coil 24V	X	X	X	X	X	X	X	X	X
NS	S400-0203	Orifice Parts Bag 2 Tube 45K	X			X			X		
NS	S400-0204	Orifice Parts Bag 3 Tube 67.5K		X			X			X	
NS	S400-0205	Orifice Parts Bag 4 Tube 90K			X			X			X
NS	6031-009	Coremax Valve Core	X	X	X	X	X	X	X	X	X

NS - Not Shown

Refer to drawing on page 10

FUNCTIONAL COMPONENTS

Drawing No.	Part No.	Description	W30G3DAXA	W30G3DAXB	W30G3DAXC	W30G3DBXA	W30G3DBXB	W30G3DBXC	W30G3DCXA	W30G3DCXB	W30G3DCXC
1	S900-267	Complete Blower Assembly 230/208	X	X	X	X	X	X			
1	S900-276	Complete Blower Assembly 460V							X	X	X
2	7004-040	20 x 25 x 2 Pleated Filter (Standard)	X	X	X	X	X	X	X	X	X
2	7003-042	20 x 25 x 1 AF Filter (Optional)	X	X	X	X	X	X	X	X	X
3	5151-045	Fan Blade	X	X	X	X	X	X	X	X	X
4	5051-066BX	Standard Outdoor Coil	X	X	X	X	X	X	X	X	X
4	5054-066BX	Coated Outdoor Coil									
			(Optional Coil in Place of Standard)								
5	5060-148BX	Standard Indoor Coil	X	X	X	X	X	X	X	X	X
5	5062-148BX	Coated Indoor Coil									
			(Optional Coil in Place of Standard)								
6	Heat Exch.	See Burner Components Diagram	X	X	X	X	X	X	X	X	X
7	8406-103	.55" + .05" Pressure Switch	X	X	X	X	X	X	X	X	X
9	8109-014	Induced Draft Blower 230V w/Transition	X	X	X	X	X	X			
9	8109-015	Induced Draft Blower 460V w/Transition							X	X	X
10	8600-011	Suppression Ignition Cable	X	X	X	X	X	X	X	X	X
11	3000-1121	Wire Assembly	X	X	X	X	X	X			
11	3000-1124	Wire Assembly							X	X	X
12	8200-001	Fan Motor Mount	X	X	X	X	X	X	X	X	X
13	8103-013	Motor 230/208V	X	X	X	X	X	X			
13	8103-020	Motor 460V							X	X	X
14	8000-298	Compressor ZP29K5E-PFV	X	X	X		X	X			
14	8000-299	Compressor ZP29K5E-TF5				X	X	X			
14	8000-300	Compressor ZP29K5E-TFD							X	X	X
15	1804-0462	High Pressure Switch (Flare)	X	X	X	X	X	X	X	X	X
16	1804-0386	Low Pressure Switch (Flare)	X	X	X	X	X	X	X	X	X
17	CMA-28	Low Ambient Control - Opt. - (Flare)	X	X	X	X	X	X	X	X	X
NS	5651-146	Check Valve	X	X	X	X	X	X	X	X	X
NS	5650-044	Molded Plug	X	X	X	X	X	X	X	X	X
NS	5650-045	Three Way Valve with Solenoid	X	X	X	X	X	X	X	X	X
NS	5651-205	Expansion Valve	X	X	X	X	X	X	X	X	X
NS	5051-120BX	Reheat Coil	X	X	X	X	X	X	X	X	X
NS	5054-120BX	Coated Reheat Coil									
			(Optional Coil in Place of Standard)								
NS	5201-017	Filter Drier	X	X	X	X	X	X	X	X	X
NS	8408-038	Freeze Thermostat	X	X	X	X	X	X	X	X	X
NS	5650-046	Solenoid Coil 24V	X	X	X	X	X	X	X	X	X
NS	S400-0203	Orifice Parts Bag 2 Tube 45K	X			X			X		
NS	S400-0204	Orifice Parts Bag 3 Tube 67.5K		X			X			X	
NS	S400-0205	Orifice Parts Bag 4 Tube 90K			X			X			X
NS	6031-009	Coremax Valve Core	X	X	X	X	X	X	X	X	X

NS - Not Shown

Refer to drawing on page 10

FUNCTIONAL COMPONENTS

Drawing No.	Part No.	Description	W36G3DAXA	W36G3DAXB	W36G3DAXC	W36G3DBXA	W36G3DBXB	W36G3DBXC	W36G3DCXA	W36G3DCXB	W36G3DCXC
1	S900-267	Complete Blower Assembly 230/208	X	X	X	X	X	X			
1	S900-276	Complete Blower Assembly 460V							X	X	X
2	7004-040	20 x 25 x 2 Pleated Filter (Standard)	X	X	X	X	X	X	X	X	X
2	7003-042	20 x 25 x 1 AF Filter (Optional)	X	X	X	X	X	X	X	X	X
3	5151-045	Fan Blade	X	X	X	X	X	X	X	X	X
4	5051-196BX	Standard Outdoor Coil	X	X	X	X	X	X	X	X	X
4	5054-196BX	Coated Outdoor Coil									
			(Optional Coil in Place of Standard)								
5	5060-148BX	Standard Indoor Coil	X	X	X	X	X	X	X	X	X
5	5062-148BX	Coated Indoor Coil									
			(Optional Coil in Place of Standard)								
6	Heat Exch.	See Burner Components Diagram	X	X	X	X	X	X	X	X	X
7	8406-103	.55" + .05" Pressure Switch	X	X	X	X	X	X	X	X	X
9	8109-014	Induced Draft Blower 230V w/Transition	X	X	X	X	X	X			
9	8109-015	Induced Draft Blower 460V w/Transition							X	X	X
10	8600-011	Suppression Ignition Cable	X	X	X	X	X	X	X	X	X
11	3000-1121	Wire Assembly	X	X	X	X	X	X			
11	3000-1124	Wire Assembly							X	X	X
12	8200-001	Fan Motor Mount	X	X	X	X	X	X	X	X	X
13	8103-013	Motor 230/208V	X	X	X	X	X	X			
13	8103-020	Motor 460V							X	X	X
14	8000-278	Compressor ZP31K5E-PFV	X	X	X						
14	8000-283	Compressor ZP31K5E-TF5				X	X	X			
14	8000-342	Compressor ZP31K5E-TFD							X	X	X
15	1804-0462	High Pressure Switch (Flare)	X	X	X	X	X	X	X	X	X
16	1804-0386	Low Pressure Switch (Flare)	X	X	X	X	X	X	X	X	X
17	CMA-28	Low Ambient Control - Opt. - (Flare)	X	X	X	X	X	X	X	X	X
NS	5651-146	Check Valve	X	X	X	X	X	X	X	X	X
NS	5650-044	Molded Plug	X	X	X	X	X	X	X	X	X
NS	5650-045	Three Way Valve with Solenoid	X	X	X	X	X	X	X	X	X
NS	5651-206	Expansion Valve	X	X	X	X	X	X	X	X	X
NS	5051-120BX	Reheat Coil	X	X	X	X	X	X	X	X	X
NS	5054-120BX	Coated Reheat Coil									
			(Optional Coil in Place of Standard)								
NS	5201-017	Filter Drier	X	X	X	X	X	X	X	X	X
NS	8408-038	Freeze Thermostat	X	X	X	X	X	X	X	X	X
NS	5650-046	Solenoid Coil 24V	X	X	X	X	X	X	X	X	X
NS	S400-0203	Orifice Parts Bag 2 Tube 45K	X			X			X		
NS	S400-0204	Orifice Parts Bag 3 Tube 67.5K		X			X			X	
NS	S400-0205	Orifice Parts Bag 4 Tube 90K			X			X			X
NS	6031-009	Coremax Valve Core	X	X	X	X	X	X	X	X	X

NS - Not Shown

Refer to drawing on page 10

BURNER COMPONENTS

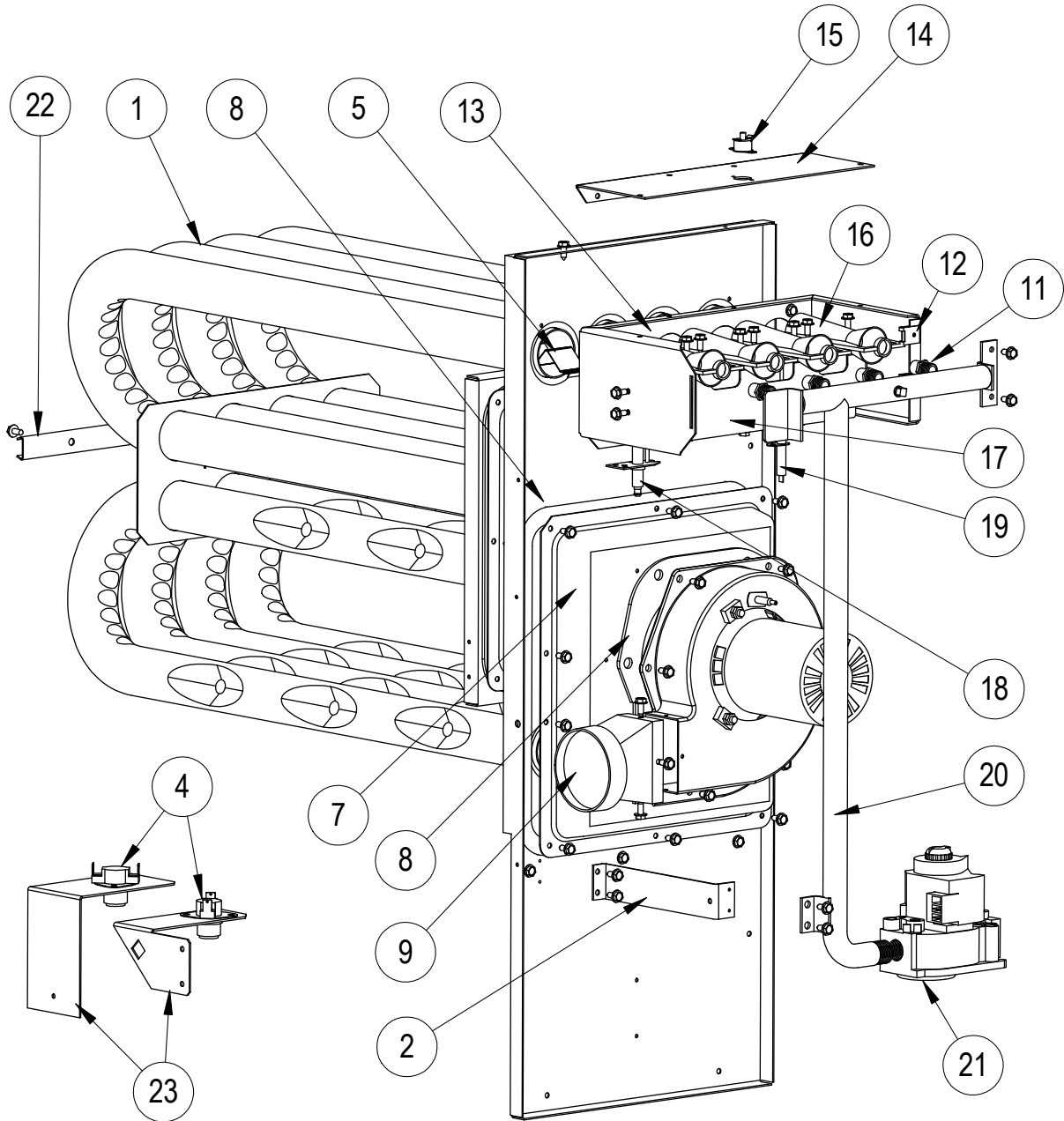

SEXP-678 A

This drawing to be used for reference for pages 15, 16 and 17

BURNER COMPONENTS

Drawing No.	Part No.	Description	W24G3D*XA	W24G3D*NA	W24G3D*XB	W24G3D*NB	W24G3D*XC	W24G3D*NC
1	S171-303	Heat Exchanger Assembly (2 Burner)	X	X				
1	S171-305	Heat Exchanger Assembly (3 Burner)			X	X		
1	S171-307	Heat Exchanger Assembly (4 Burner)					X	X
2	113-268	Manifold Bracket	X	X	X	X	X	X
4	8402-180	Limit Control L140-30	X	X				
4	8402-178	Limit Control L120-30			X	X		
4	8402-177	Limit Control L115-30					X	X
5	9010-083	NOx Screen		2		3		4
7	168-142	Collector Box	X	X				
7	168-143	Collector Box			X	X		
7	168-144	Collector Box					X	X
8	1921-043	Gasket Set	X	X	X	X	X	X
9	5809-013	3" Cast Inducer Transition	X	X	X	X	X	X
11	9010-082	Orifice 2.30mm (.0885 diameter)	2	2	3	3	4	4
11	9010-087	Orifice 2.20mm (10% derate)	2	2	3	3	4	4
12	1012-314	U Clip Fastener	2	2	2	2	2	2
13	163-050	Burner Box	X	X				
13	163-049	Burner Box			X	X		
13	163-052	Burner Box					X	X
14	141-440	Flame Rollout Support	X	X	X	X		
14	141-438	Flame Rollout Support					X	X
15	8402-124	Flame Rollout Switch L270	X	X	X	X	X	X
16	9010-078	In-Shot Burner 2.5 x 4.5	2	2	3	3	4	4
17	163-048	Burner Support	X	X				
17	163-041	Burner Support			X	X		
17	163-043	Burner Support					X	X
18	8554-024	DSI Spark Igniter	X	X	X	X	X	X
19	8554-025	Flame Sensor	X	X	X	X	X	X
20	5818-053	2-Hole Gas Manifold - 1/2"	X	X				
20	5818-054	3-Hole Gas Manifold - 1/2"			X	X		
20	5818-055	4-Hole Gas Manifold - 1/2"					X	X
21	5651-160	Natural Gas Valve 1/2 x 1/2	X	X	X	X	X	X
22	168-140	Tube Brace 2 Burner	X	X				
22	168-135	Tube Brace 3 Burner			X	X		
22	168-134	Tube Brace 4 Burner					X	X
23	112-355	Limit Bracket	X	X				
23	112-475	Limit Bracket			X	X	X	X
NS	8600-011	Ignition Cable	X	X	X	X	X	X

NS – Not Shown

Refer to drawing on page 14

BURNER COMPONENTS

Drawing No.	Part No.	Description	W30G3D*XA	W30G3D*NA	W30G3D*XB	W30G3D*NB	W30G3D*XC	W30G3D*NC
1	S171-303	Heat Exchanger Assembly (2 Burner)	X	X				
1	S171-305	Heat Exchanger Assembly (3 Burner)			X	X		
1	S171-307	Heat Exchanger Assembly (4 Burner)					X	X
2	113-268	Manifold Bracket	X	X	X	X	X	X
4	8402-180	Limit Control L140-30	X	X				
4	8402-178	Limit Control L120-30			X	X		
4	8402-177	Limit Control L115-30					X	X
5	9010-083	NOx Screen		2		3		4
7	168-142	Collector Box	X	X				
7	168-143	Collector Box			X	X		
7	168-144	Collector Box					X	X
8	1921-043	Gasket Set	X	X	X	X	X	X
9	5809-013	3" Cast Inducer Transition	X	X	X	X	X	X
11	9010-082	Orifice 2.30mm (.0885 diameter)	2	2	3	3	4	4
11	9010-087	Orifice 2.20mm (10% derate)	2	2	3	3	4	4
12	1012-314	U Clip Fastener	2	2	2	2	2	2
13	163-050	Burner Box	X	X				
13	163-049	Burner Box			X	X		
13	163-052	Burner Box					X	X
14	141-440	Flame Rollout Support	X	X	X	X		
14	141-438	Flame Rollout Support					X	X
15	8402-124	Flame Rollout Switch L270	X	X	X	X	X	X
16	9010-078	In-Shot Burner 2.5 x 4.5	2	2	3	3	4	4
17	163-048	Burner Support	X	X				
17	163-041	Burner Support			X	X		
17	163-043	Burner Support					X	X
18	8554-024	DSI Spark Igniter	X	X	X	X	X	X
19	8554-025	Flame Sensor	X	X	X	X	X	X
20	5818-053	2-Hole Gas Manifold - 1/2"	X	X				
20	5818-054	3-Hole Gas Manifold - 1/2"			X	X		
20	5818-055	4-Hole Gas Manifold - 1/2"					X	X
21	5651-160	Natural Gas Valve 1/2 x 1/2	X	X	X	X	X	X
22	168-140	Tube Brace 2 Burner	X	X				
22	168-135	Tube Brace 3 Burner			X	X		
22	168-134	Tube Brace 4 Burner					X	X
23	112-355	Limit Bracket	X	X				
23	112-475	Limit Bracket			X	X	X	X
NS	8600-011	Ignition Cable	X	X	X	X	X	X

NS – Not Shown

Refer to drawing on page 14

BURNER COMPONENTS

Drawing No.	Part No.	Description	W36G3D*XA	W36G3D*NA	W36G3D*XB	W36G3D*NB	W36G3D*XC	W36G3D*NC
1	S171-303	Heat Exchanger Assembly (2 Burner)	X	X				
1	S171-305	Heat Exchanger Assembly (3 Burner)			X	X		
1	S171-307	Heat Exchanger Assembly (4 Burner)					X	X
2	113-268	Manifold Bracket	X	X	X	X	X	X
4	8402-180	Limit Control L140-30	X	X				
4	8402-178	Limit Control L120-30			X	X		
4	8402-177	Limit Control L115-30					X	X
5	9010-083	NOx Screen		2		3		4
7	168-142	Collector Box	X	X				
7	168-143	Collector Box			X	X		
7	168-144	Collector Box					X	X
8	1921-043	Gasket Set	X	X	X	X	X	X
9	5809-013	3" Cast Inducer Transition	X	X	X	X	X	X
11	9010-082	Orifice 2.30mm (.0885 diameter)	2	2	3	3	4	4
11	9010-087	Orifice 2.20mm (10% derate)	2	2	3	3	4	4
12	1012-314	U Clip Fastener	2	2	2	2	2	2
13	163-050	Burner Box	X	X				
13	163-049	Burner Box			X	X		
13	163-052	Burner Box					X	X
14	141-440	Flame Rollout Support	X	X	X	X		
14	141-438	Flame Rollout Support					X	X
15	8402-124	Flame Rollout Switch L270	X	X	X	X	X	X
16	9010-078	In-Shot Burner 2.5 x 4.5	2	2	3	3	4	4
17	163-048	Burner Support	X	X				
17	163-041	Burner Support			X	X		
17	163-043	Burner Support					X	X
18	8554-024	DSI Spark Igniter	X	X	X	X	X	X
19	8554-025	Flame Sensor	X	X	X	X	X	X
20	5818-053	2-Hole Gas Manifold - 1/2"	X	X				
20	5818-054	3-Hole Gas Manifold - 1/2"			X	X		
20	5818-055	4-Hole Gas Manifold - 1/2"					X	X
21	5651-160	Natural Gas Valve 1/2 x 1/2	X	X	X	X	X	X
22	168-140	Tube Brace 2 Burner	X	X				
22	168-135	Tube Brace 3 Burner			X	X		
22	168-134	Tube Brace 4 Burner					X	X
23	112-355	Limit Bracket	X	X				
23	112-475	Limit Bracket			X	X	X	X
NS	8600-011	Ignition Cable	X	X	X	X	X	X

NS – Not Shown

Refer to drawing on page 14

CONTROL PANEL

Drawing No.	Part No.	Description	W24G3DA	W24G3DB	W24G3DC	W30G3DA	W30G3DB	W30G3DC	W36G3DA	W36G3DB	W36G3DC
1	5651-159	Integrated Furnace Control	X	X	X	X	X	X	X	X	X
2	8201-086	460 Volt Relay DPDT			X			X			X
3	8201-032	460 Volt Relay SPDT			3			3			3
4	8407-035	Transformer 50 VA 208/240 - 24V	X	X		X	X		X	X	
4	8407-042	Transformer 50 VA 480 - 24V			X			X			X
5	8401-006	Contactor, 2-Pole, 20A	X	X		X	X		X	X	
5	8401-002	Contactor, 3-Pole, 25A			X			X			X
6	8201-157	Compressor Control Module	X	X	X	X	X	X	X	X	X
7	8552-002	Capacitor 5MFD 370 V 1-1/4" Oval		X	X		X	X		X	X
7	8552-050	Capacitor 40+5MFD 370 V 2-1/2" Round	X								
7	8552-052	Capacitor 45+5MFD 370 V 2-1/2" Round				X			X		
8	8201-126	Phase Monitor		X	X		X	X		X	X
9	135-130	Wire Shield	X	X	X	X	X	X	X	X	X
10	517-276	Control Panel Assembly	X	X	X	X	X	X	X	X	X
11	117-248	Low Voltage Partition	X	X	X	X	X	X	X	X	X
12	8615-057	Circuit Breaker 30A, 2 Pole	X								
12	8615-051	Circuit Breaker 25A, 3 Pole		X			X				
12	8615-067	460V 40A Toggle Disconnect			X			X			X
12	8615-069	Switch Cover Plate			X			X			X
12	8615-038	Circuit Breaker 35A, 2 Pole				X					
12	8615-055	Circuit Breaker 40A, 2 Pole							X		
12	8615-042	Circuit Breaker 35A, 3 Pole								X	
13	135-266	High Voltage Barrier			X			X			X
14	113-269	Circuit Breaker Mounting Base	X	X		X	X		X	X	
14	113-393	Toggle Disconnect Base			X			X			X
15	8201-113	Dehumidification Logic Control Board	X	X	X	X	X	X	X	X	X
16	117-247	Low Voltage Box	X	X	X	X	X	X	X	X	X
17	8607-024	Low Voltage Terminal Strip	X	X	X	X	X	X	X	X	X
18	8201-048	Relay DPDT	X	X	X	X	X	X	X	X	X
NS	4085-165	Wiring Diagram	X								
NS	4085-263	Wiring Diagram		X							
NS	4085-386	Wiring Diagram			X						
NS	4085-167	Wiring Diagram				X			X		
NS	4085-265	Wiring Diagram					X			X	
NS	4085-388	Wiring Diagram						X			X

NS – Not Shown

BLOWER ASSEMBLY

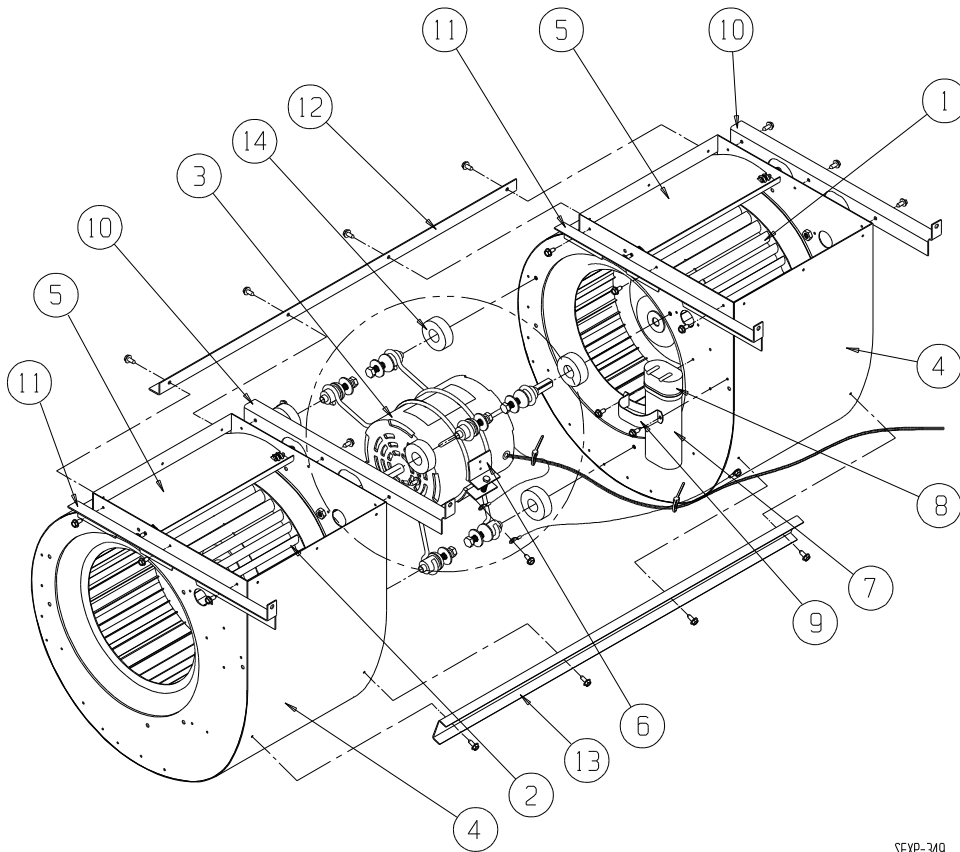

SEXP-349

Drawing No.	Part No.	Description	S900-266	S900-267	S900-275	S900-276
1	5152-096	Blower Wheel 10-6	X	X	X	X
2	5152-072	Blower Wheel 10-6	X	X	X	X
3	8105-049	Motor 230/208 V		X		
3	8620-208	Motor 460V				X
3	8104-017	Motor 230/208 V	X			
3	8620-207	Motor 460V			X	
4	151-117	Blower Housing	2	2	2	2
5	144-167	Diffuser	2	2	2	2
6	8200-040	Motor Mount	X	X	X	X
7	8552-004	Capacitor 7.5 MFD 370V	X	X	X	X
8	8611-002	Capacitor Boot	X	X	X	X
9	8550-003	Capacitor Bracket	X	X	X	X
10	105X1075	Angle – Right	2	2	2	2
11	105Y1075	Angle – Left	2	2	2	2
12	105-1109	Angle – Back	X	X	X	X
13	165-572	Channel – Front	X	X	X	X
14	5451-011	Grommets	3	3	3	3