

---

# REPLACEMENT PARTS MANUAL

---

## WALL MOUNTED GAS/ELECTRIC

Models:

W42G3DA W48G3DA W60G3DA  
W42G3DB W48G3DB W60G3DB  
W42G3DC W48G3DC W60G3DC

---

### Contents

Description	Page	Description	Page
Cabinet Components		Blower Assembly	
♦ Exploded View .....	2	♦ Exploded View .....	20
♦ Usage List .....	3	♦ Usage List .....	20
♦ Usage List .....	4		
♦ Usage List .....	5		
♦ Usage List .....	6		
♦ Usage List .....	7		
♦ Usage List .....	8		
Functional Components			
♦ Exploded View .....	10		
♦ Usage List .....	11		
♦ Usage List .....	12		
♦ Usage List .....	13		
Burner Components			
♦ Exploded View .....	14		
♦ Usage List .....	15		
♦ Usage List .....	16		
♦ Usage List .....	17		
Control Panel			
♦ Exploded View .....	18		
♦ Usage List .....	19		

### General Notes

- Revised and/or additional pages may be issued from time to time.
- A complete and current manual consists of pages shown in the following contents section.

### Important

- Contact the installing and/or local Bard distributor for all parts requirements. Make sure you have the complete model and serial number available from the unit rating plates.



Bard Manufacturing Company, Inc.  
Bryan, Ohio 43506  
[www.bardhvac.com](http://www.bardhvac.com)

Manual: 2110-820G  
Supersedes: 2110-820F  
Date: 5-28-19

# CABINET COMPONENTS

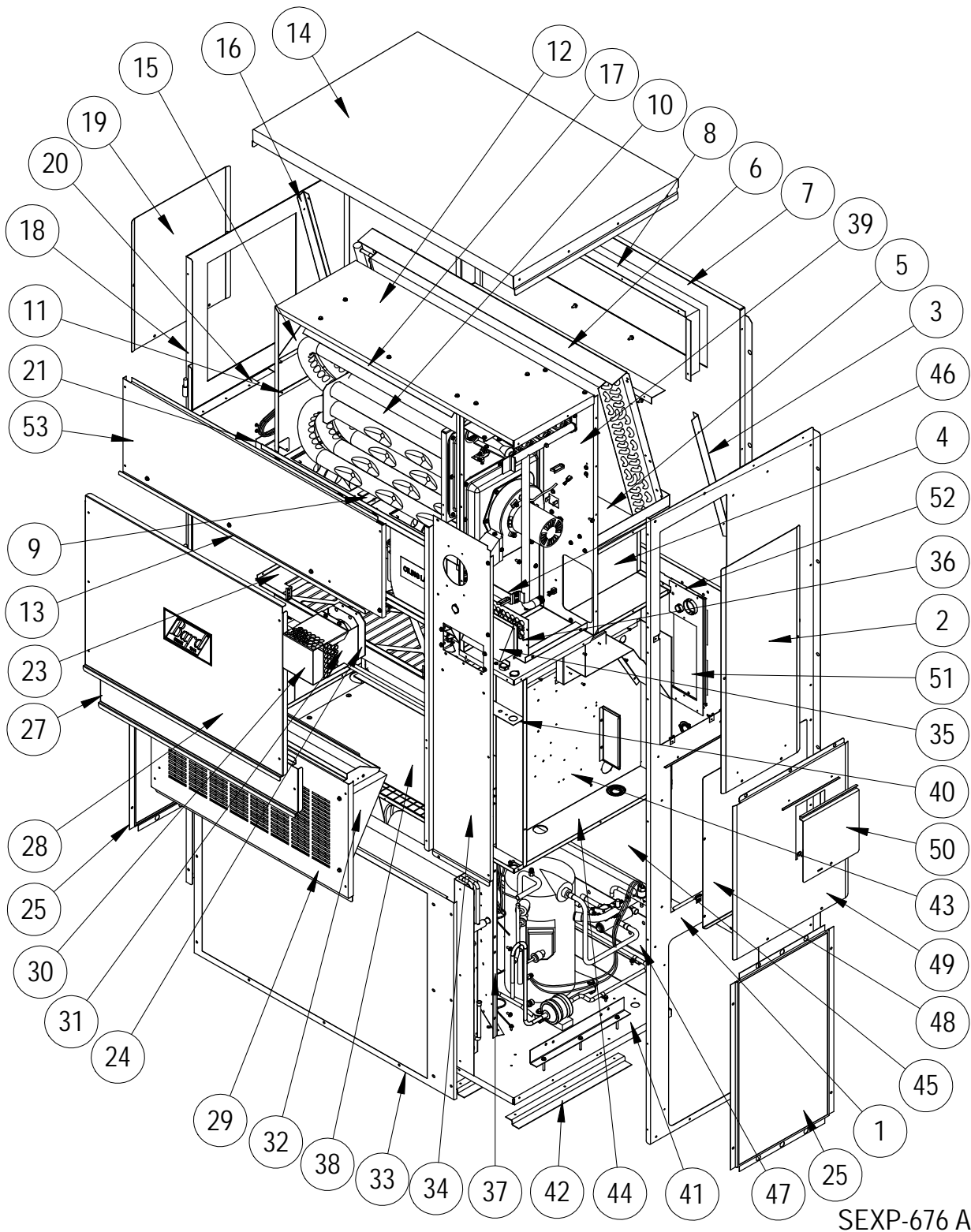

SEXP-676 A

This drawing to be used for reference for pages 3, 4, 5, 6, 7 and 8

# CABINET COMPONENTS

Drawing No.	Part No.	Description	W42G3DAXB	W42G3DAXC	W42G3DAXD	W42G3DBXB	W42G3DBXC	W42G3DBXD	W42G3DCXB	W42G3DCXC	W42G3DCXD
1	501-570-*	Right Side Assembly	X	X	X	X	X	X	X	X	X
2	S153-326-*	Vestibule Service Door	X	X	X	X	X	X	X	X	X
3	105X1073	Right Evaporator Support Angle	X	X	X	X	X	X	X	X	X
4	541-266	Right Drain Pan Support Assembly	X	X	X	X	X	X	X	X	X
5	S523-123	Drain Pan Assembly	X	X	X	X	X	X	X	X	X
6	105-1080	Evaporator Coil Fill Angle	X	X	X	X	X	X	X	X	X
7	509-156	Upper Back	X	X	X	X	X	X	X	X	X
8	111-063	Supply Air Frame	2	2	2	2	2	2	2	2	2
9	103-439	Heat Exchanger Support Offset	X	X	X	X	X	X	X	X	X
10	Heat Exch Assy	See Burner Components Diagram									
11	105-1066	Top Heat Exchanger Deflector	X	X	X	X	X	X	X	X	X
12	135-216	Inner Air Baffle	X	X	X	X	X	X	X	X	X
13	165-563-*	Top Rain Channel	X	X	X	X	X	X	X	X	X
14	507-246-*	Top Assembly	X	X	X	X	X	X	X	X	X
15	135-184	Right Heat Exchanger Deflector	X	X	X	X	X	X	X	X	X
16	105Y1073	Left Evaporator Support Angle	X	X	X	X	X	X	X	X	X
17	105-1076	Lower Heat Exchanger Deflector	X	X	X	X	X	X	X	X	X
18	501-571-*	Left Side Assembly	X	X	X	X	X	X	X	X	X
19	543-070-*	Left Access Cover	X	X	X	X	X	X	X	X	X
20	105-1070	Left Support Angle	X	X	X	X	X	X	X	X	X
21	S121-484	Blower Partition	X	X	X	X	X	X	X	X	X
23	131-163	Filter Tray	X	X	X	X	X	X	X	X	X
24	1921-051	Vent Terminal Gasket	X	X	X	X	X	X	X	X	X
25	118-084-*	Side Grille	2	2	2	2	2	2	2	2	2
<i>Continued on page 4</i>											

\* Exterior cabinet parts are manufactured with various paint color options. To ensure the proper paint color is received, reference the following codes: Beige -X, Buckeye Gray -4, Dark Bronze -8

**Refer to drawing on page 2**

# CABINET COMPONENTS

Drawing No.	Part No.	Description	W42G3DAXB	W42G3DAXC	W42G3DAXD	W42G3DBXB	W42G3DBXC	W42G3DBXD	W42G3DCXB	W42G3DCXC	W42G3DCXD
<i>Continued from page 3</i>											
27	553-562-*	Filter Access Panel Assembly	X	X	X	X	X	X	X	X	X
28	S553-561-*	Front Door Assembly	X	X	X	X	X	X	X	X	X
29	553-327-*	Vent Option Door Assembly	X	X	X	X	X	X	X	X	X
30	169-119	Outer Vent Hood	X	X	X	X	X	X	X	X	X
31	169-120	Inner Vent Hood	X	X	X	X	X	X	X	X	X
32	WGBFAD-5	Barometric Fresh Air Damper	X	X	X	X	X	X	X	X	X
33	118-048-*	Condenser Grille	X	X	X	X	X	X	X	X	X
34	549-131-*	Right Front Corner Assembly	X	X	X	X	X	X	X	X	X
35	S135-181-*	Air Intake Hood	X	X	X	X	X	X	X	X	X
36	S134-182-*	Air Intake Back	X	X	X	X	X	X	X	X	X
37	125-024	Fan Shroud	X	X	X	X	X	X	X	X	X
38	542-136	Condenser Partition Blank Off Plate	X	X	X	X	X	X	X	X	X
39	541-398	Heat Exchanger Support Assembly	X	X	X	X	X	X	X	X	X
40	142-071	Filter Blank Off Plate	X	X	X	X	X	X	X	X	X
41	127-561	Lower Base	X	X	X	X	X	X	X	X	X
42	103-438	Lower Base Offset	3	3	3	3	3	3	3	3	3
43	S902-1484	Control Panel Assembly	X	X	X						
43	S902-1485	Control Panel Assembly				X	X	X			
43	S902-1486	Control Panel Assembly							X	X	X
44	521-447	Condenser Partition Assembly	X	X	X	X	X	X	X	X	X
45	509-157	Lower Back Assembly	X	X	X	X	X	X	X	X	X
46	113-268	Manifold Bracket	X	X	X	X	X	X	X	X	X
47	113-140	Bottom Support Bracket	X	X	X	X	X	X	X	X	X
48	S133-163	Circuit Breaker Inner Door	X	X	X	X	X	X			
48	S133-205	Toggle Disconnect Inner Door							X	X	X
49	S533-162-*	Control Panel Cover Assembly	X	X	X	X	X	X	X	X	X
50	S153-328-*	Disconnect Access Door	X	X	X	X	X	X	X	X	X
51	134-193	Conduit Access Panel	X	X	X	X	X	X	X	X	X
52	156-029	Conduit Entrance Plate	X	X	X	X	X	X	X	X	X
53	553-388-*	Upper Door Assembly	X	X	X	X	X	X	X	X	X

\* Exterior cabinet parts are manufactured with various paint color options. To ensure the proper paint color is received, reference the following codes: Beige -X, Buckeye Gray -4, Dark Bronze -8

**Refer to drawing on page 2**

# CABINET COMPONENTS

Drawing No.	Part No.	Description	W48G3DAXB	W48G3DAXC	W48G3DAXD	W48G3DBXB	W48G3DBXC	W48G3DBXD	W48G3DCXB	W48G3DCXC	W48G3DCXD
1	501-570-*	Right Side Assembly	X	X	X	X	X	X	X	X	X
2	S153-326-*	Vestibule Service Door	X	X	X	X	X	X	X	X	X
3	105X1073	Right Evaporator Support Angle	X	X	X	X	X	X	X	X	X
4	541-266	Right Drain Pan Support Assembly	X	X	X	X	X	X	X	X	X
5	S523-123	Drain Pan Assembly	X	X	X	X	X	X	X	X	X
6	105-1080	Evaporator Coil Fill Angle	X	X	X	X	X	X	X	X	X
7	509-156	Upper Back	X	X	X	X	X	X	X	X	X
8	111-063	Supply Air Frame	2	2	2	2	2	2	2	2	2
9	103-439	Heat Exchanger Support Offset	X	X	X	X	X	X	X	X	X
10	Heat Exch Assy	See Burner Components Diagram									
11	105-1066	Top Heat Exchanger Deflector	X	X	X	X	X	X	X	X	X
12	135-216	Inner Air Baffle	X	X	X	X	X	X	X	X	X
13	165-563-*	Top Rain Channel	X	X	X	X	X	X	X	X	X
14	507-246-*	Top Assembly	X	X	X	X	X	X	X	X	X
15	135-184	Right Heat Exchanger Deflector	X	X	X	X	X	X	X	X	X
16	105Y1073	Left Evaporator Support Angle	X	X	X	X	X	X	X	X	X
17	105-1076	Lower Heat Exchanger Deflector	X	X	X	X	X	X	X	X	X
18	501-571-*	Left Side Assembly	X	X	X	X	X	X	X	X	X
19	543-070-*	Left Access Cover	X	X	X	X	X	X	X	X	X
20	105-1070	Left Support Angle	X	X	X	X	X	X	X	X	X
21	S121-484	Blower Partition	X	X	X	X	X	X	X	X	X
23	131-163	Filter Tray	X	X	X	X	X	X	X	X	X
24	1921-051	Vent Terminal Gasket	X	X	X	X	X	X	X	X	X
25	118-084-*	Side Grille	2	2	2	2	2	2	2	2	2
<i>Continued on page 6</i>											

\* Exterior cabinet parts are manufactured with various paint color options. To ensure the proper paint color is received, reference the following codes: Beige -X, Buckeye Gray -4, Dark Bronze -8

**Refer to drawing on page 2**

# CABINET COMPONENTS

Drawing No.	Part No.	Description	W48G3DAXB	W48G3DAXC	W48G3DAXD	W48G3DBXB	W48G3DBXC	W48G3DBXD	W48G3DCXB	W48G3DCXC	W48G3DCXD
<i>Continued from page 5</i>											
27	553-562-*	Filter Access Panel Assembly	X	X	X	X	X	X	X	X	X
28	S553-561-*	Front Door Assembly	X	X	X	X	X	X	X	X	X
29	553-327-*	Vent Option Door Assembly	X	X	X	X	X	X	X	X	X
30	169-119	Outer Vent Hood	X	X	X	X	X	X	X	X	X
31	169-120	Inner Vent Hood	X	X	X	X	X	X	X	X	X
32	WGBFAD-5	Barometric Fresh Air Damper	X	X	X	X	X	X	X	X	X
33	118-048-*	Condenser Grille	X	X	X	X	X	X	X	X	X
34	549-131-*	Right Front Corner Assembly	X	X	X	X	X	X	X	X	X
35	S135-181-*	Air Intake Hood	X	X	X	X	X	X	X	X	X
36	S134-182-*	Air Intake Back	X	X	X	X	X	X	X	X	X
37	125-024	Fan Shroud	X	X	X	X	X	X	X	X	X
38	542-136	Condenser Partition Blank Off Plate	2	2	2	2	2	2	2	2	2
39	541-398	Heat Exchanger Support Assembly	X	X	X	X	X	X	X	X	X
40	142-071	Filter Blank Off Plate	X	X	X	X	X	X	X	X	X
41	127-561	Lower Base	X	X	X	X	X	X	X	X	X
42	103-438	Lower Base Offset	3	3	3	3	3	3	3	3	3
43	S902-1487	Control Panel Assembly	X	X	X						
43	S902-1488	Control Panel Assembly				X	X	X			
43	S902-1489	Control Panel Assembly							X	X	X
44	521-447	Condenser Partition Assembly	X	X	X	X	X	X	X	X	X
45	509-157	Lower Back Assembly	X	X	X	X	X	X	X	X	X
46	113-268	Manifold Bracket	X	X	X	X	X	X	X	X	X
47	113-140	Bottom Support Bracket	X	X	X	X	X	X	X	X	X
48	S133-163	Circuit Breaker Inner Door	X	X	X	X	X				
48	S133-205	Toggle Disconnect Inner Door							X	X	X
49	S533-162-*	Control Panel Cover Assembly	X	X	X	X	X	X	X	X	X
50	S153-328-*	Disconnect Access Door	X	X	X	X	X	X	X	X	X
51	134-193	Conduit Access Panel	X	X	X	X	X	X	X	X	X
52	156-029	Conduit Entrance Plate	X	X	X	X	X	X	X	X	X
53	553-388-*	Upper Door Assembly	X	X	X	X	X	X	X	X	X

\* Exterior cabinet parts are manufactured with various paint color options. To ensure the proper paint color is received, reference the following codes: Beige -X, Buckeye Gray -4, Dark Bronze -8

**Refer to drawing on page 2**

# CABINET COMPONENTS

Drawing No.	Part No.	Description	W60G3DAXB	W60G3DAXC	W60G3DAXD	W60G3DBXB	W60G3DBXC	W60G3DBXD	W60G3DCXB	W60G3DCXC	W60G3DCXD
1	501-570-*	Right Side Assembly	X	X	X	X	X	X	X	X	X
2	S153-326-*	Vestibule Service Door	X	X	X	X	X	X	X	X	X
3	105X1073	Right Evaporator Support Angle	X	X	X	X	X	X	X	X	X
4	541-266	Right Drain Pan Support Assembly	X	X	X	X	X	X	X	X	X
5	S523-123	Drain Pan Assembly	X	X	X	X	X	X	X	X	X
6	105-1080	Evaporator Coil Fill Angle	X	X	X	X	X	X	X	X	X
7	509-156	Upper Back	X	X	X	X	X	X	X	X	X
8	111-063	Supply Air Frame	2	2	2	2	2	2	2	2	2
9	103-439	Heat Exchanger Support Offset	X	X	X	X	X	X	X	X	X
10	Heat Exch Assy	See Burner Components Diagram									
11	105-1066	Top Heat Exchanger Deflector	X	X	X	X	X	X	X	X	X
12	135-216	Inner Air Baffle	X	X	X	X	X	X	X	X	X
13	165-563-*	Top Rain Channel	X	X	X	X	X	X	X	X	X
14	507-246-*	Top Assembly	X	X	X	X	X	X	X	X	X
15	135-184	Right Heat Exchanger Deflector	X	X	X	X	X	X	X	X	X
16	105Y1073	Left Evaporator Support Angle	X	X	X	X	X	X	X	X	X
17	105-1076	Lower Heat Exchanger Deflector	X	X	X	X	X	X	X	X	X
18	501-571-*	Left Side Assembly	X	X	X	X	X	X	X	X	X
19	543-070-*	Left Access Cover	X	X	X	X	X	X	X	X	X
20	105-1070	Left Support Angle	X	X	X	X	X	X	X	X	X
21	S121-484	Blower Partition	X	X	X	X	X	X	X	X	X
23	131-163	Filter Tray	X	X	X	X	X	X	X	X	X
24	1921-051	Vent Terminal Gasket	X	X	X	X	X	X	X	X	X
25	118-084-*	Side Grille	2	2	2	2	2	2	2	2	2
<i>Continued on page 8</i>											

\* Exterior cabinet parts are manufactured with various paint color options. To ensure the proper paint color is received, reference the following codes: Beige -X, Buckeye Gray -4, Dark Bronze -8

**Refer to drawing on page 2**

# CABINET COMPONENTS

Drawing No.	Part No.	Description	W60G3DAXB	W60G3DAXC	W60G3DAXD	W60G3DBXB	W60G3DBXC	W60G3DBXD	W60G3DCXB	W60G3DCXC	W60G3DCXD
<i>Continued from page 7</i>											
27	553-562-*	Filter Access Panel Assembly	X	X	X	X	X	X	X	X	X
28	S553-561-*	Front Door Assembly	X	X	X	X	X	X	X	X	X
29	553-327-*	Vent Option Door Assembly	X	X	X	X	X	X	X	X	X
30	169-119	Outer Vent Hood	X	X	X	X	X	X	X	X	X
31	169-120	Inner Vent Hood	X	X	X	X	X	X	X	X	X
32	WGBFAD-5	Barometric Fresh Air Damper	X	X	X	X	X	X	X	X	X
33	118-048-*	Condenser Grille	X	X	X	X	X	X	X	X	X
34	549-131-*	Right Front Corner Assembly	X	X	X	X	X	X	X	X	X
35	S135-181-*	Air Intake Hood	X	X	X	X	X	X	X	X	X
36	S134-182-*	Air Intake Back	X	X	X	X	X	X	X	X	X
37	125-024	Fan Shroud	X	X	X	X	X	X	X	X	X
38	542-136	Condenser Partition Blank Off Plate	2	2	2	2	2	2	2	2	2
39	541-398	Heat Exchanger Support Assembly	X	X	X	X	X	X	X	X	X
40	142-071	Filter Blank Off Plate	X	X	X	X	X	X	X	X	X
41	127-561	Lower Base	X	X	X	X	X	X	X	X	X
42	103-438	Lower Base Offset	3	3	3	3	3	3	3	3	3
43	S902-1490	Control Panel Assembly	X	X	X						
43	S902-1491	Control Panel Assembly				X	X	X			
43	S902-1489	Control Panel Assembly							X	X	X
44	521-447	Condenser Partition Assembly	X	X	X	X	X	X	X	X	X
45	509-157	Lower Back Assembly	X	X	X	X	X	X	X	X	X
46	113-268	Manifold Bracket	X	X	X	X	X	X	X	X	X
47	113-140	Bottom Support Bracket	X	X	X	X	X	X	X	X	X
48	S133-163	Circuit Breaker Inner Door	X	X	X	X	X	X			
48	S133-205	Toggle Disconnect Inner Door							X	X	X
49	S533-162-*	Control Panel Cover Assembly	X	X	X	X	X	X	X	X	X
50	S153-328-*	Disconnect Access Door	X	X	X	X	X	X	X	X	X
51	134-193	Conduit Access Panel	X	X	X	X	X	X	X	X	X
52	156-029	Conduit Entrance Plate	X	X	X	X	X	X	X	X	X
53	553-388-*	Upper Door Assembly	X	X	X	X	X	X	X	X	X

\* Exterior cabinet parts are manufactured with various paint color options. To ensure the proper paint color is received, reference the following codes: Beige -X, Buckeye Gray -4, Dark Bronze -8

**Refer to drawing on page 2**



*This page intentionally left blank*

# FUNCTIONAL COMPONENTS

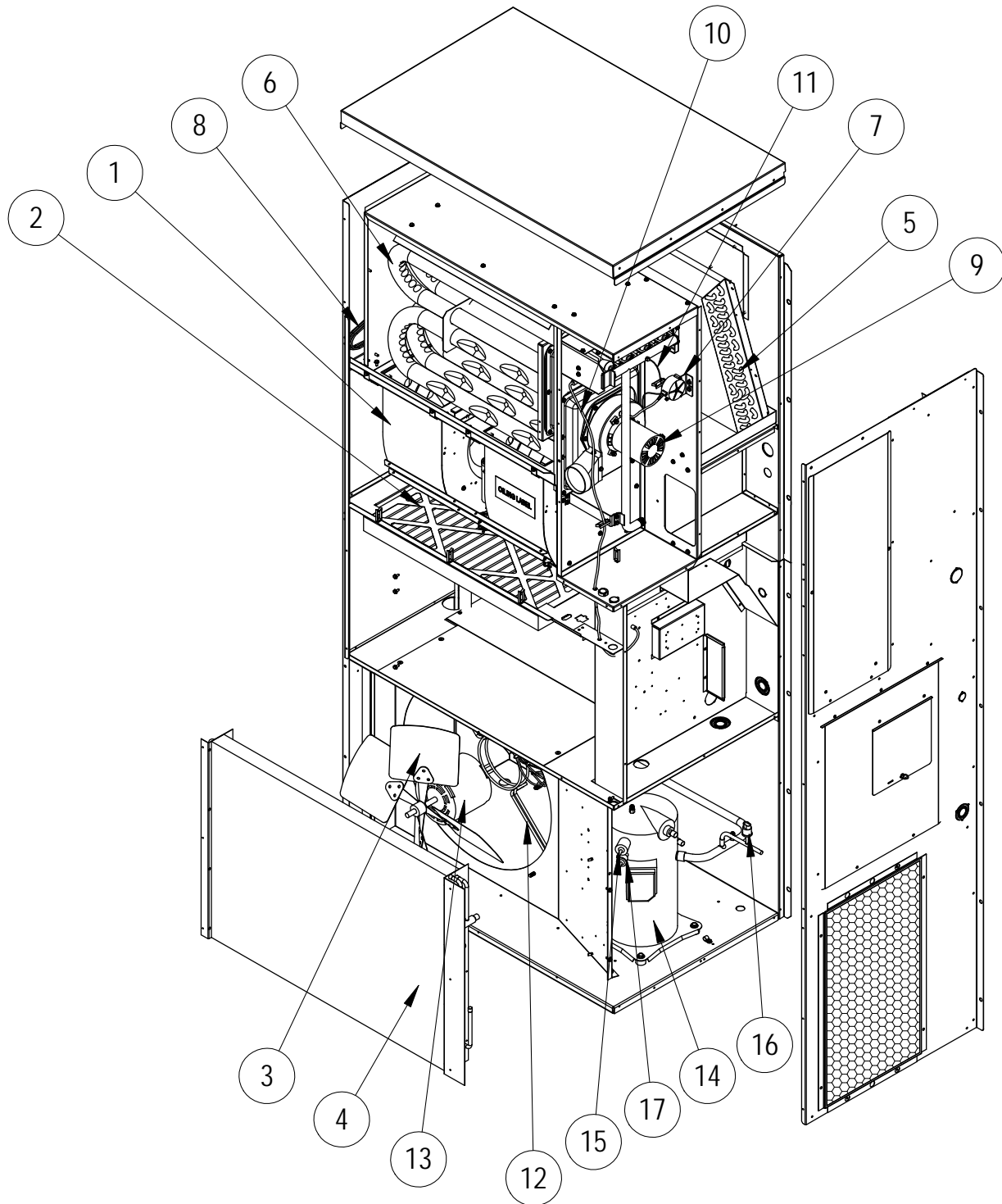

SEXP-677

**This drawing to be used for reference for pages 11, 12 and 13**

# FUNCTIONAL COMPONENTS

Drawing No.	Part No.	Description	W42G3DAXB	W42G3DAXC	W42G3DAXD	W42G3DBXB	W42G3DBXC	W42G3DBXD	W42G3DCXB	W42G3DCXC	W42G3DCXD
1	S900-249	Complete Blower Assembly 230/208	X	X	X	X	X	X			
1	S900-277	Complete Blower Assembly 460V							X	X	X
2	7004-027	20 x 30 x 2 Pleated Filter (Standard)	X	X	X	X	X	X	X	X	X
2	7003-030	20 x 30 x 1 AF Filter (Optional)	X	X	X	X	X	X	X	X	X
3	S5151-060	Fan Blade	X	X	X	X	X	X	X	X	X
4	5051-179BX	Coil	X	X	X	X	X	X	X	X	X
5	5060-106BX	Coil	X	X	X	X	X	X	X	X	X
6	Heat Exch.	See Burner Components Diagram	X	X	X	X	X	X	X	X	X
7	8406-103	.55" + .05" Pressure Switch	X	X	X	X	X	X	X	X	X
8	5625-043	Drain Back Orifice	X	X	X	X	X	X	X	X	X
9	8109-014	Induced Draft Blower 230V w/Transition	X	X	X	X	X				
9	8109-015	Induced Draft Blower 460V w/Transition							X	X	X
10	8600-011	Suppression Ignition Cable	X	X	X	X	X	X	X	X	X
11	3000-1121	Wire Assembly	X	X	X	X	X				
11	3000-1124	Wire Assembly							X	X	X
12	8200-004	Fan Motor Mount	X	X	X	X	X	X	X	X	X
13	8105-068	Motor 230/208V	X	X	X	X	X				
13	8105-071	Motor 460V							X	X	X
14	8000-318	Compressor ZP39K5E-PFV	X	X	X						
14	8000-319	Compressor ZP39K5E-TF5				X	X	X			
14	8000-320	Compressor ZP39K5E-TFD							X	X	X
15	1804-0462	High Pressure Switch (Flare)	X	X	X	X	X	X	X	X	X
16	1804-0386	Low Pressure Switch (Flare)	X	X	X	X	X	X	X	X	X
17	CMA-28	Low Ambient Control (Opt.)	X	X	X	X	X	X	X	X	X
NS	8408-048	Freeze Thermostat	X	X	X	X	X	X	X	X	X
NS	5625-008	Distributor	X	X	X	X	X	X	X	X	X
NS	5651-207	Expansion Valve	X	X	X	X	X	X	X	X	X
NS	5651-146	Check Valve	X	X	X	X	X	X	X	X	X
NS	5650-044	Molded Plug	X	X	X	X	X	X	X	X	X
NS	5650-045	Three Way Valve with Solenoid	X	X	X	X	X	X	X	X	X
NS	5051-102BX	Reheat Coil	X	X	X	X	X	X	X	X	X
NS	5201-018	Filter Drier	X	X	X	X	X	X	X	X	X
NS	5650-046	Solenoid Coil 24V	X	X	X	X	X	X	X	X	X
NS	S400-0183	Orifice Parts Bag 3 Tube 75K	X			X			X		
NS	S400-0184	Orifice Parts Bag 4 Tube 100K		X			X			X	
NS	S400-0185	Orifice Parts Bag 5 Tube 125K			X			X			X
NS	6031-009	Coremax Valve Core	X	X	X	X	X	X	X	X	X

NS – Not Shown

**Refer to drawing on page 10**

# FUNCTIONAL COMPONENTS

Drawing No.	Part No.	Description	W48G3DAXB	W48G3DAXC	W48G3DAXD	W48G3DBXB	W48G3DBXC	W48G3DBXD	W48G3DCXB	W48G3DCXC	W48G3DCXD
1	S900-249	Complete Blower Assembly 230/208	X	X	X	X	X	X			
1	S900-277	Complete Blower Assembly 460V							X	X	X
2	7004-027	20 x 30 x 2 Pleated Filter (Standard)	X	X	X	X	X	X	X	X	X
2	7003-030	20 x 30 x 1 AF Filter (Optional)	X	X	X	X	X	X	X	X	X
3	S5151-060	Fan Blade	X	X	X	X	X	X	X	X	X
4	5051-180BX	Coil	X	X	X	X	X	X	X	X	X
5	5060-106BX	Coil	X	X	X	X	X	X	X	X	X
6	Heat Exch.	See Burner Components Diagram	X	X	X	X	X	X	X	X	X
7	8406-103	.55" + .05" Pressure Switch	X	X	X	X	X	X	X	X	X
8	5625-043	Drain Back Orifice	X	X	X	X	X	X	X	X	X
9	8109-014	Induced Draft Blower 230V w/Transition	X	X	X	X	X	X			
9	8109-015	Induced Draft Blower 460V w/Transition							X	X	X
10	8600-011	Suppression Ignition Cable	X	X	X	X	X	X	X	X	X
11	3000-1121	Wire Assembly	X	X	X	X	X	X			
11	3000-1124	Wire Assembly							X	X	X
12	8200-004	Fan Motor Mount	X	X	X	X	X	X	X	X	X
13	8105-068	Motor 230/208V	X	X	X	X	X	X			
13	8105-071	Motor 460V							X	X	X
14	8000-332	Compressor ZP42K5E-PFV	X	X	X						
14	8000-333	Compressor ZP42K5E-TF5				X	X	X			
14	8000-334	Compressor ZP42K5E-TFD							X	X	X
15	1804-0462	High Pressure Switch (Flare)	X	X	X	X	X	X	X	X	X
16	1804-0386	Low Pressure Switch (Flare)	X	X	X	X	X	X	X	X	X
17	CMA-28	Low Ambient Control (Opt.)	X	X	X	X	X	X	X	X	X
NS	8408-048	Freeze Thermostat	X	X	X	X	X	X	X	X	X
NS	5625-008	Distributor	X	X	X	X	X	X	X	X	X
NS	5651-208	Expansion Valve	X	X	X	X	X	X	X	X	X
NS	5651-146	Check Valve	X	X	X	X	X	X	X	X	X
NS	5650-044	Molded Plug	X	X	X	X	X	X	X	X	X
NS	5650-045	Three Way Valve with Solenoid	X	X	X	X	X	X	X	X	X
NS	5051-102BX	Reheat Coil	X	X	X	X	X	X	X	X	X
NS	5201-018	Filter Drier	X	X	X	X	X	X	X	X	X
NS	5650-046	Solenoid Coil 24V	X	X	X	X	X	X	X	X	X
NS	S400-0183	Orifice Parts Bag 3 Tube 75K	X			X			X		
NS	S400-0184	Orifice Parts Bag 4 Tube 100K		X			X			X	
NS	S400-0185	Orifice Parts Bag 5 Tube 125K			X			X			X
NS	6031-009	Coremax Valve Core	X	X	X	X	X	X	X	X	X

NS – Not Shown

Refer to drawing on page 10

# FUNCTIONAL COMPONENTS

Drawing No.	Part No.	Description	W60G3DAXB	W60G3DAXC	W60G3DAXD	W48G3DBXB	W60G3DBXC	W60G3DBXD	W60G3DCXB	W60G3DCXC	W60G3DCXD
1	S900-249	Complete Blower Assembly 230/208	X	X	X	X	X	X			
1	S900-277	Complete Blower Assembly 460V							X	X	X
2	7004-027	20 x 30 x 2 Pleated Filter (Standard)	X	X	X	X	X	X	X	X	X
2	7003-030	20 x 30 x 1 AF Filter (Optional)	X	X	X	X	X	X	X	X	X
3	S5151-060	Fan Blade	X	X	X	X	X	X	X	X	X
4	5051-180BX	Coil	X	X	X	X	X	X	X	X	X
5	5060-105BX	Coil	X	X	X	X	X	X	X	X	X
6	Heat Exch.	See Burner Components Diagram	X	X	X	X	X	X	X	X	X
7	8406-103	.55" + .05" Pressure Switch	X	X	X	X	X	X	X	X	X
8	5625-043	Drain Back Orifice	X	X	X	X	X	X	X	X	X
9	8109-014	Induced Draft Blower 230V w/Transition	X	X	X	X	X	X			
9	8109-015	Induced Draft Blower 460V w/Transition							X	X	X
10	8600-011	Suppression Ignition Cable	X	X	X	X	X	X	X	X	X
11	3000-1121	Wire Assembly	X	X	X	X	X	X			
11	3000-1124	Wire Assembly							X	X	X
12	8200-004	Fan Motor Mount	X	X	X	X	X	X	X	X	X
13	8105-068	Motor 230/208V	X	X	X	X	X	X			
13	8105-071	Motor 460V							X	X	X
14	8000-324	Compressor ZP54K5E-PFV	X	X	X						
14	8000-325	Compressor ZP54K5E-TF5				X	X	X			
14	8000-326	Compressor ZP54K5E-TFD							X	X	X
15	1804-0462	High Pressure Switch (Flare)	X	X	X	X	X	X	X	X	X
16	1804-0386	Low Pressure Switch (Flare)	X	X	X	X	X	X	X	X	X
17	CMA-28	Low Ambient Control (Opt.)	X	X	X	X	X	X	X	X	X
NS	8408-048	Freeze Thermostat	X	X	X	X	X	X	X	X	X
NS	5625-036	Distributor	X	X	X	X	X	X	X	X	X
NS	5651-208	Expansion Valve	X	X	X	X	X	X	X	X	X
NS	5651-146	Check Valve	X	X	X	X	X	X	X	X	X
NS	5650-044	Molded Plug	X	X	X	X	X	X	X	X	X
NS	5650-045	Three Way Valve with Solenoid	X	X	X	X	X	X	X	X	X
NS	5051-102BX	Reheat Coil	X	X	X	X	X	X	X	X	X
NS	5201-018	Filter Drier	X	X	X	X	X	X	X	X	X
NS	5650-046	Solenoid Coil 24V	X	X	X	X	X	X	X	X	X
NS	S400-0183	Orifice Parts Bag 3 Tube 75K	X			X			X		
NS	S400-0184	Orifice Parts Bag 4 Tube 100K		X			X			X	
NS	S400-0185	Orifice Parts Bag 5 Tube 125K			X			X			X
NS	6031-009	Coremax Valve Core	X	X	X	X	X	X	X	X	X

NS – Not Shown

Refer to drawing on page 10



# BURNER COMPONENTS

Drawing No.	Part No.	Description	W42G3D*XB	W42G3D*NB	W42G3D*XC	W42G3D*NC	W42G3D*XD	W42G3D*ND
1	S171-315	Heat Exchanger Assembly 75K	X	X				
1	S171-317	Heat Exchanger Assembly 100K			X	X		
1	S171-319	Heat Exchanger Assembly 125K					X	X
2	113-268	Manifold Bracket	X	X	X	X	X	X
4	8402-180	Limit Control L140-30	X	X				
4	8402-178	Limit Control L120-30			X	X		
4	8402-177	Limit Control L115-30					X	X
5	9010-083	NOx Screen		3		4		5
6	1921-025-4600	46" Glas-Tak Tape	X	X	X	X	X	X
7	168-126	Collector Box	X	X				
7	168-127	Collector Box			X	X		
7	168-128	Collector Box					X	X
8	1921-044	Gasket Set	X	X	X	X	X	X
9	5809-013	3" Cast Inducer Transition	X	X	X	X	X	X
10	5809-017	3.031" x 4.625" Transition	X	X	X	X	X	X
11	9010-079	Orifice 2.40mm (.0960 diameter)	3		4		5	5
11	9010-082	Orifice 2.30mm (10% derate & .0905 diameter)	3	3	4	4	5	5
12	1012-314	U Clip Fastener	4	4	4	4	4	4
13	163-049	Burner Box	X	X				
13	163-052	Burner Box			X	X		
13	163-051	Burner Box					X	X
14	141-493	Flame Rollout Support	X	X				
14	141-494	Flame Rollout Support			X	X		
14	141-439	Flame Rollout Support					X	X
15	8402-124	Flame Rollout Switch L270	X	X	X	X	X	X
16	9010-078	In-Shot Burner 2.5 x 4.5	3	3	4	4	5	5
17	163-048	Burner Support	X	X				
17	163-041	Burner Support			X	X		
17	163-043	Burner Support					X	X
18	8554-024	DSI Spark Igniter	X	X	X	X	X	X
19	8554-025	Flame Sensor	X	X	X	X	X	X
20	5818-054	2-Hole Gas Manifold - 1/2"	X	X				
20	5818-055	3-Hole Gas Manifold - 1/2"			X	X		
20	5818-056	4-Hole Gas Manifold - 1/2"					X	X
21	5651-160	Natural Gas Valve 1/2 x 1/2	X	X	X	X	X	X
22	168-140	Tube Brace 2 Burner	X	X				
22	168-135	Tube Brace 3 Burner			X	X		
22	168-134	Tube Brace 4 Burner					X	X
23	112-355	Limit Bracket	X	X				
23	112-475	Limit Bracket			X	X	X	X
NS	8600-011	Ignition Cable	X	X	X	X	X	X

NS – Not Shown

Refer to drawing on page 14

# BURNER COMPONENTS

Drawing No.	Part No.	Description	W48G3D*XB	W48G3D*NB	W48G3D*XC	W48G3D*NC	W48G3D*XD	W48G3D*ND
1	S171-315	Heat Exchanger Assembly 75K	X	X				
1	S171-317	Heat Exchanger Assembly 100K			X	X		
1	S171-319	Heat Exchanger Assembly 125K					X	X
2	113-268	Manifold Bracket	X	X	X	X	X	X
4	8402-180	Limit Control L140-30	X	X				
4	8402-178	Limit Control L120-30			X	X		
4	8402-177	Limit Control L115-30					X	X
5	9010-083	NOx Screen		3		4		5
6	1921-025-4600	46" Glas-Tak Tape	X	X	X	X	X	X
7	168-126	Collector Box	X	X				
7	168-127	Collector Box			X	X		
7	168-128	Collector Box					X	X
8	1921-044	Gasket Set	X	X	X	X	X	X
9	5809-013	3" Cast Inducer Transition	X	X	X	X	X	X
10	5809-017	3.031" x 4.625" Transition	X	X	X	X	X	X
11	9010-079	Orifice 2.40mm (.0960 diameter)	3		4		5	5
11	9010-082	Orifice 2.30mm (10% derate & .0905 diameter)	3	3	4	4	5	5
12	1012-314	U Clip Fastener	4	4	4	4	4	4
13	163-049	Burner Box	X	X				
13	163-052	Burner Box			X	X		
13	163-051	Burner Box					X	X
14	141-493	Flame Rollout Support	X	X				
14	141-494	Flame Rollout Support			X	X		
14	141-439	Flame Rollout Support					X	X
15	8402-124	Flame Rollout Switch L270	X	X	X	X	X	X
16	9010-078	In-Shot Burner 2.5 x 4.5	3	3	4	4	5	5
17	163-041	Burner Support	X	X				
17	163-043	Burner Support			X	X		
17	163-045	Burner Support					X	X
18	8554-024	DSI Spark Igniter	X	X	X	X	X	X
19	8554-025	Flame Sensor	X	X	X	X	X	X
20	5818-054	2-Hole Gas Manifold - 1/2"	X	X				
20	5818-055	3-Hole Gas Manifold - 1/2"			X	X		
20	5818-056	4-Hole Gas Manifold - 1/2"					X	X
21	5651-160	Natural Gas Valve 1/2 x 1/2	X	X	X	X	X	X
22	168-140	Tube Brace 2 Burner	X	X				
22	168-135	Tube Brace 3 Burner			X	X		
22	168-134	Tube Brace 4 Burner					X	X
23	112-355	Limit Bracket	X	X				
23	112-475	Limit Bracket			X	X	X	X
NS	8600-011	Ignition Cable	X	X	X	X	X	X

NS – Not Shown

Refer to drawing on page 14



# BURNER COMPONENTS

Drawing No.	Part No.	Description	W60G3D*XB	W60G3D*NB	W60G3D*XC	W60G3D*NC	W60G3D*XD	W60G3D*ND
1	S171-315	Heat Exchanger Assembly 75K	X	X				
1	S171-317	Heat Exchanger Assembly 100K			X	X		
1	S171-319	Heat Exchanger Assembly 125K					X	X
2	113-268	Manifold Bracket	X	X	X	X	X	X
4	8402-180	Limit Control L140-30	X	X				
4	8402-178	Limit Control L120-30			X	X		
4	8402-177	Limit Control L115-30					X	X
5	9010-083	NOx Screen		3		4		5
6	1921-025-4600	46" Glas-Tak Tape	X	X	X	X	X	X
7	168-126	Collector Box	X	X				
7	168-127	Collector Box			X	X		
7	168-128	Collector Box					X	X
8	1921-044	Gasket Set	X	X	X	X	X	X
9	5809-013	3" Cast Inducer Transition	X	X	X	X	X	X
10	5809-017	3.031" x 4.625" Transition	X	X	X	X	X	X
11	9010-079	Orifice 2.40mm (.0960 diameter)	3		4		5	5
11	9010-082	Orifice 2.30mm (10% derate & .0905 diameter)	3	3	4	4	5	5
12	1012-314	U Clip Fastener	4	4	4	4	4	4
13	163-049	Burner Box	X	X				
13	163-052	Burner Box			X	X		
13	163-051	Burner Box					X	X
14	141-493	Flame Rollout Support	X	X				
14	141-494	Flame Rollout Support			X	X		
14	141-439	Flame Rollout Support					X	X
15	8402-124	Flame Rollout Switch L270	X	X	X	X	X	X
16	9010-078	In-Shot Burner 2.5 x 4.5	3	3	4	4	5	5
17	163-041	Burner Support	X	X				
17	163-043	Burner Support			X	X		
17	163-045	Burner Support					X	X
18	8554-024	DSI Spark Igniter	X	X	X	X	X	X
19	8554-025	Flame Sensor	X	X	X	X	X	X
20	5818-054	2-Hole Gas Manifold - 1/2"	X	X				
20	5818-055	3-Hole Gas Manifold - 1/2"			X	X		
20	5818-056	4-Hole Gas Manifold - 1/2"					X	X
21	5651-160	Natural Gas Valve 1/2 x 1/2	X	X	X	X	X	X
22	168-140	Tube Brace 2 Burner	X	X				
22	168-135	Tube Brace 3 Burner			X	X		
22	168-134	Tube Brace 4 Burner					X	X
23	112-355	Limit Bracket	X	X				
23	112-475	Limit Bracket			X	X	X	X
NS	8600-011	Ignition Cable	X	X	X	X	X	X

NS – Not Shown

Refer to drawing on page 14

# CONTROL PANEL

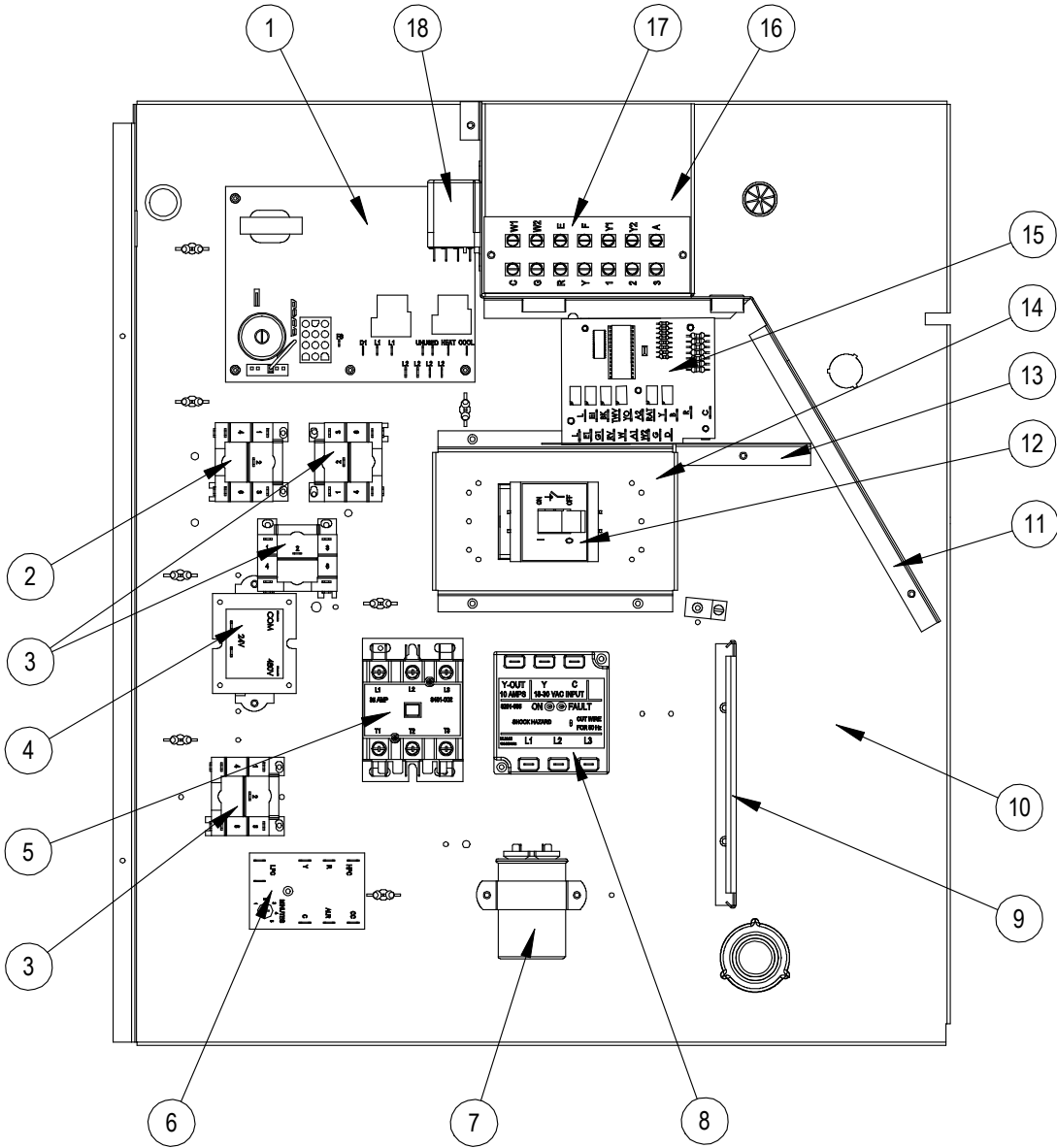

SEXP-567

# CABINET COMPONENTS

Drawing No.	Part No.	Description	W42G3DA	W42G3DB	W42G3DC	W48G3DA	W48G3DB	W48G3DC	W60G3DA	W60G3DB	W60G3DC
1	5651-159	Integrated Furnace Control	X	X	X	X	X	X	X	X	X
2	8201-086	460 Volt Relay DPDT			X			X			X
3	8201-032	460 Volt Relay SPDT			3			3			3
4	8407-068	Transformer 50 VA 208/240 - 24V	X	X		X	X		X	X	
4	8407-069	Transformer 50 VA 480 - 24V			X			X			X
5	8401-025	Contactor 2-Pole 40 Amp	X	X		X	X		X	X	
5	8401-002	Contactor 3-Pole 25 Amp			X			X			X
6	8201-164	Compressor Control Module	X	X	X	X	X	X	X	X	X
7	8552-005	Capacitor 10MFD 370 V 1-1/4" Oval		X			X			X	
7	8552-004	Capacitor 7.5MFD 370 V 1-1/4" Oval			X			X			X
7	8552-079	Capacitor 45+10MFD 370 V 2-1/2" Round	X								
7	8552-089	Capacitor 70+10MFD 370 V 2-1/2" Round				X					
7	8552-058	Capacitor 80+10MFD 370 V 2-1/2" Round							X		
8	8201-126	Phase Monitor		X	X		X	X		X	X
9	135-130	Wire Shield	X	X	X	X	X	X	X	X	X
10	517-276	Control Panel Assembly	X	X	X	X	X	X	X	X	X
11	117-248	Low Voltage Partition	X	X	X	X	X	X	X	X	X
12	8615-040	Circuit Breaker 50A, 2 Pole	X			X					
12	8615-042	Circuit Breaker 35A, 3 Pole		X			X				
12	8615-067	460V 40A Toggle Disconnect			X			X			X
12	8615-069	Switch Cover Plate			X			X			X
12	8615-041	Circuit Breaker 60A, 2 Pole							X		
12	8615-043	Circuit Breaker 40A, 3 Pole								X	
13	135-266	High Voltage Barrier			X			X			X
14	113-269	Circuit Breaker Mounting Base	X	X		X	X		X	X	
14	113-393	Toggle Disconnect Base			X			X			X
15	8201-113	Dehumidification Logic Control Board	X	X	X	X	X	X	X	X	X
16	117-247	Low Voltage Box	X	X	X	X	X	X	X	X	X
17	8607-024	Low Voltage Terminal Strip	X	X	X	X	X	X	X	X	X
18	8201-048	Relay DPDT	X	X	X	X	X	X	X	X	X
NS	4085-167	Wiring Diagram	X								
NS	4085-265	Wiring Diagram		X							
NS	4085-388	Wiring Diagram			X						
NS	4085-169	Wiring Diagram				X			X		
NS	4085-267	Wiring Diagram					X			X	
NS	4085-390	Wiring Diagram						X			X

NS – Not Shown

# BLOWER ASSEMBLY

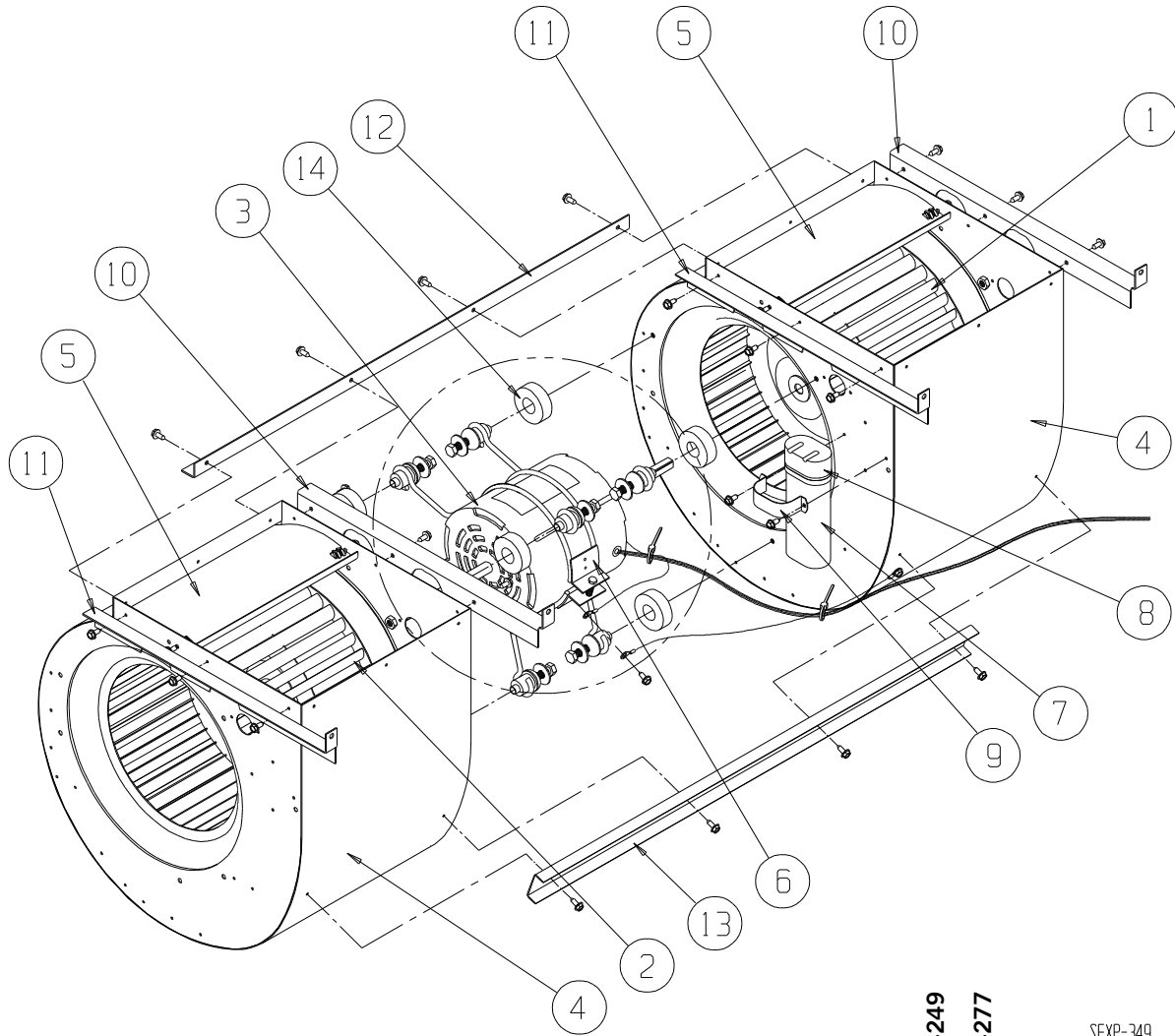

S900-249  
S900-277

SEXP-349

Drawing No.	Part No.	Description	S900-249	S900-277
1	5152-011	Blower Wheel 10-8	X	X
2	5152-012	Blower Wheel 10-8	X	X
3	8106-038	Motor 230/208 V	X	
3	8620-209	Motor 460V		X
4	151-101	Blower Housing	2	2
5	144-166	Diffuser	2	2
6	8200-040	Motor Mount	X	X
7	8552-005	Capacitor 10 MFD 370V	X	X
8	8611-002	Capacitor Boot	X	X
9	8550-003	Capacitor Bracket	X	X
10	105X1075	Angle – Right	2	2
11	105Y1075	Angle – Left	2	2
12	105-881	Angle – Back	X	X
13	165-564	Channel – Front	X	X
14	5451-011	Grommets	3	3