

REPLACEMENT PARTS MANUAL

HIGH ECONOMY GAS FIRED FURNACES

MODELS: IH60D36E, IH85D48E, IH115D48E
IH115D60E, IH145D60E

Manual 2110-853

Revision I

Date 11-20-95

Supersedes 12-15-93

* GENERAL NOTES *

*Revised and/or additional pages may be issued from time to time.
*A complete and current manual consists of pages dated as shown in the following index.

** INDEX **

<u>Page</u>	<u>Description</u>	<u>Page</u>	<u>Date</u>	<u>Supersedes</u>
Cabinet	Components--Exploded View	1	9-23-91	3-22-91
"	--Usage List	2	11-20-95	3-26-92
Functional	Components--Exploded View	3	9-23-91	2-19-90
"	--Usage List	4	U-20-95	12-15-93

*** IMPORTANT ***

Contact the installing and/or local Bard distributor for all parts requirements. Make sure you have the complete model and serial number available from the unit rating plate.

BARD MANUFACTURING COMPANY

BRYAN, OHIO 43506

CABINET COMPONENTS

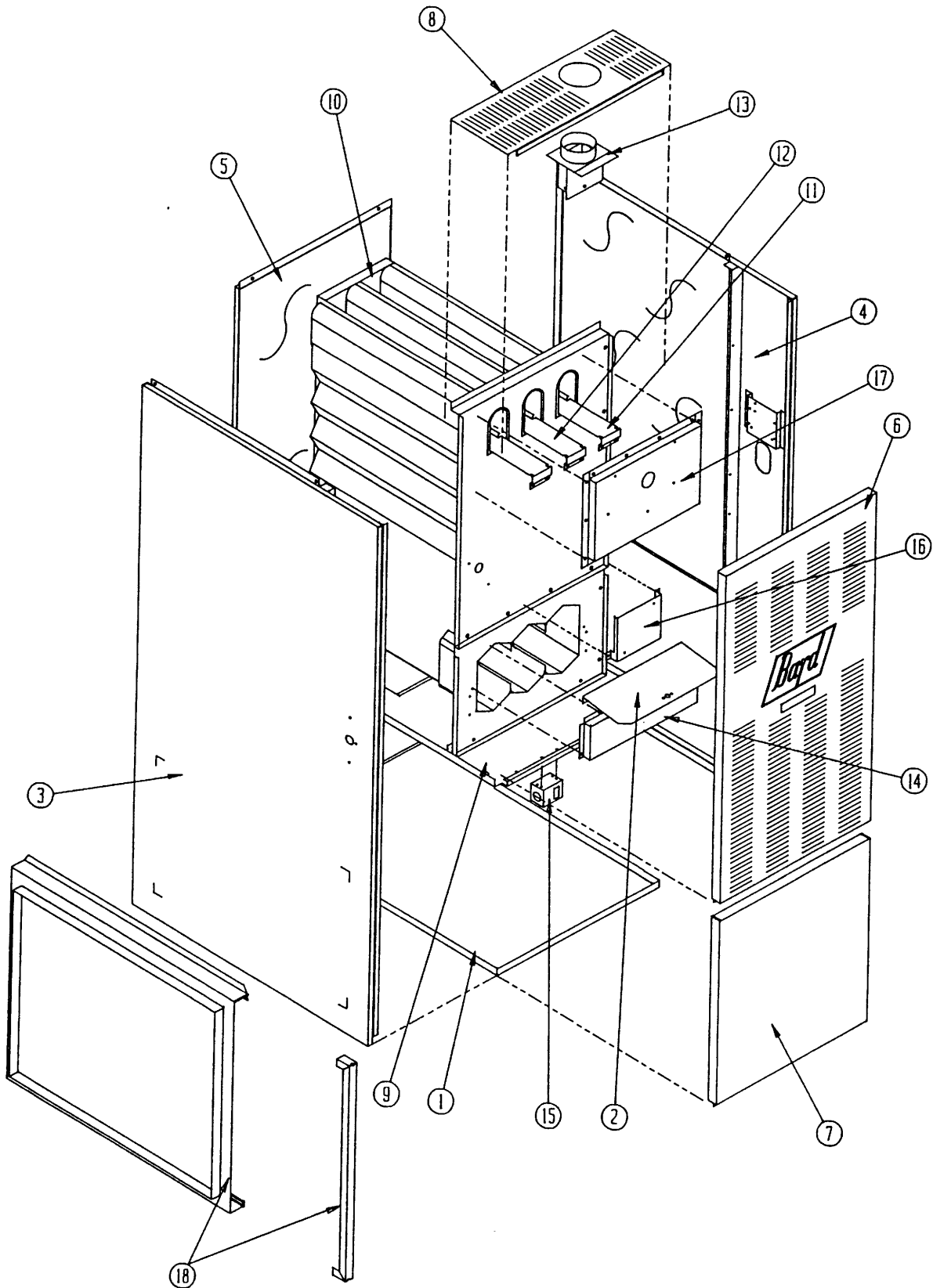

IR85D48D model shown above

Date: 9-23-91
Supersedes: 3-22-91

2110-853
Page: 1

CABINET COMPONENTS

Dwg. No.	Part No.	Description	I	I	I	I	I
			H	H	H	H	H
			6	8	1	1	1
			0	5	1	1	4
			D	D	5	5	5
			3	4	D	D	D
			6	8	4	6	6
			E	E	8	0	0
					E	E	E
1	127-188	Lower Base Assembly	X				
1	127-189	Lower Base Assembly		X			
1	127-190	Lower Base Assembly			X	X	
1	127-191	Lower Base Assembly					X
2	140-159	Switch Support	X				
2	140-160	Switch Support		X			
2	140-161	Switch Support			X	X	
2	140-162	Switch Support					X
3	501-235	Left Side Assembly	X	X	X	X	X
4	501-234	Right Side Assembly	X	X	X	X	X
5	508-017	Back Assembly	X				
5	508-018	Back Assembly		X			
5	508-019	Back Assembly			X	X	
5	508-073	Back Assembly					X
6	152-048	Burner Door	X				
6	152-050	Burner Door		X			
6	152-052	Burner Door			X	X	
6	152-200	Burner Door					X
7	152-037	Blower Door	X				
7	152-039	Blower Door		X			
7	152-043	Blower Door			X	X	
7	152-153	Blower Door					X
8	106-040	Top Fill	X				
8	106-041	Top Fill		X			
8	106-042	Top Fill			X	X	
8	106-079	Top Fill					X
9	127-118	Blower Base	X				
9	127-119	Blower Base		X			
9	127-187	Blower Base					X
9	127-203	Blower Base				X	
10	171-175	Heat Exchanger Assembly	X				
10	171-138	Heat Exchanger Assembly		X			
10	171-144	Heat Exchanger Assembly			X	X	
10	171-155	Heat Exchanger Assembly					X
11	168-002	Internal Flue Baffle Outside	2	3	2	2	4
12	168-013	Internal Flue Baffle Inside			2	2	1
13	913-0002	Flue Stack Assembly	X				
13	913-0004	Flue Stack Assembly		X	X	X	
14	168-003	Secondary Air Baffle	X				
14	168-008	Secondary Air Baffle		X			
14	168-018	Secondary Air Baffle					X
14	168-010	Secondary Air Baffle			X	X	
15	112-031	Door Switch Bracket	X	X	X	X	X
16	112-099	Ignition Module Bracket	X	X	X	X	X
17	913-0005	Collector Box Assembly	X				
17	913-0006	Collector Box Assembly		X			
17	913-0007	Collector Box Assembly			X	X	
17	913-0008	Collector Box Assembly					X
18	919-0002	Filter Rack W/Door	X	X	X		
18	919-0003	Filter Rack W/Door				X	X

FUNCTIONAL COMPONENTS

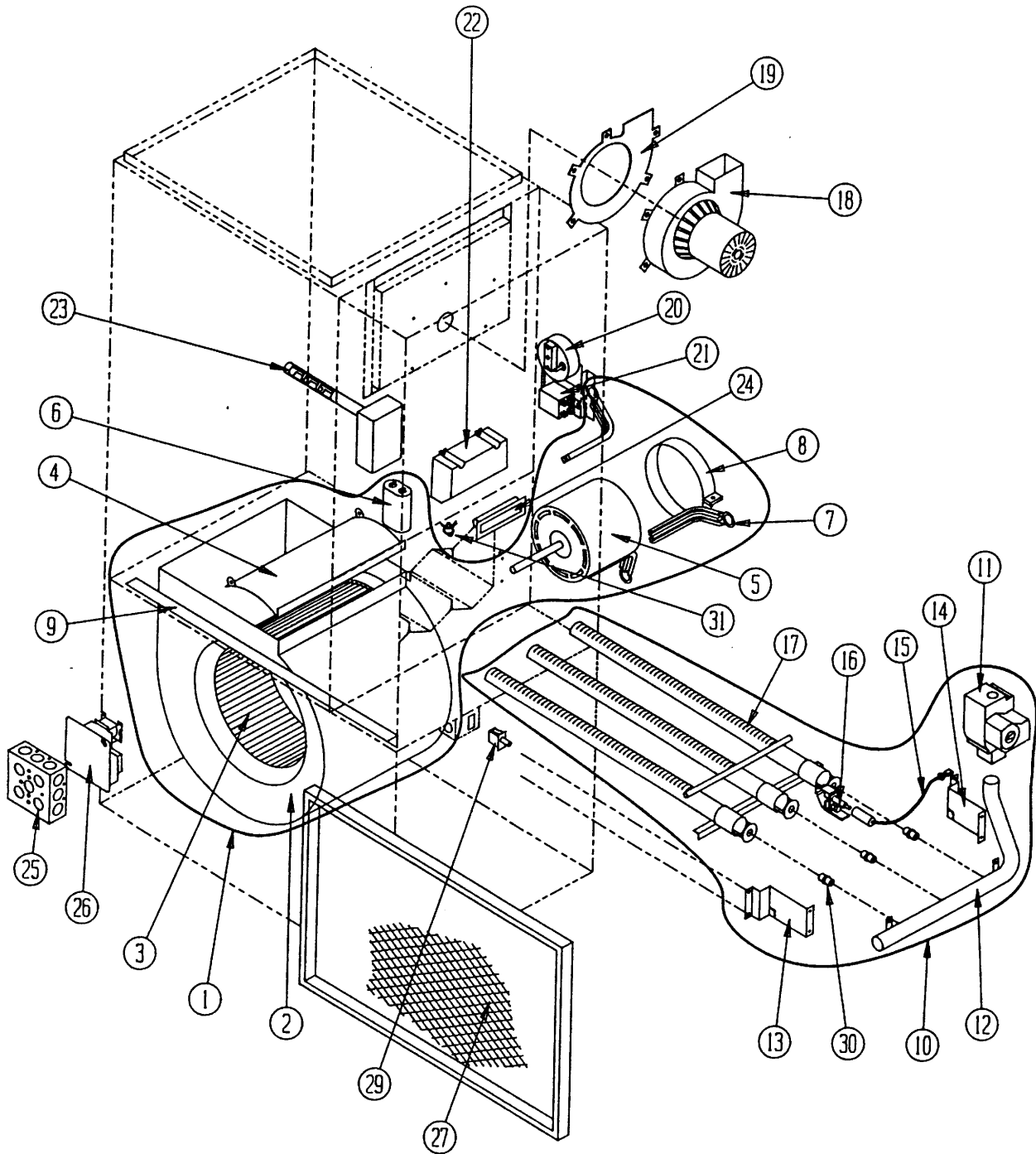

Date: 9-23-91
Supersedes: 2-19-90

FUNCTIONAL COMPONENTS

Dwg. No.	Part No.	Description	I H 6 0 D 3 6 E	I H 8 5 D 4 8 E	I H 1 1 5 D 4 8 E	I H 1 1 5 D 6 0 E	I H 1 1 5 D 6 0 E
1	900-107	Blower Assembly	x				
1	900-108	Blower Assembly		x			
1	900-110	Blower Assembly			x		
1	900-171	Blower Assembly				x	x
2	151-069	Blower Housing	x				
2	151-073	Blower Housing		x			
2	151-074	Blower Housing			x		
2	151-084	Blower Housing				x	x
3	5152-010	Blower Wheel	x				
3	5152-014	Blower Wheel		x			
3	5152-059	Blower Wheel			x		
3	5152-061	Blower Wheel				x	x
4	144-125	Diffuser	x				
4	144-128	Diffuser		x			
4	144-129	Diffuser			x		
4	144-131	Diffuser				x	x
5	8105-008	Motor	x				
5	8105-009	Motor		x			
5	8106-018	Motor			x		
5	8107-004	Motor				x	x
6	8552-002	Capacitor	x	x			
6	8552-004	Capacitor			x		
6	8552-026	Capacitor				x	x
7	8200-036	Motor Mount Arm	3				
7	8200-034	Motor Mount Arm		3	3	3	3
8	8200-033	Motor Mount Band	x	x	x	x	x
9	104-793	Blower Angle	x	x	x		
9	104-792	Blower Angle				x	x
10	901-0074	Burner Assembly	x				
10	901-0050	Burner Assembly		x			
10	901-0061	Burner Assembly			x	x	
10	901-0076	Burner Assembly					x
11	5651-062	Gas Valve	x	x	x	x	x
12	5818-019	Manifold 2-Hole	x				
12	5818-020	Manifold 3-Hole		x			
12	5818-021	Manifold 4-Hole			x	x	
12	5818-022	Manifold 5-Hole					x
13	112Y095	Left Manifold Bracket	x	x	x	x	x
14	112X095	Right Manifold Bracket	x	x	x	x	x
15	8600-009	Ignition Cable	x	x	x	x	x
16	8620-038	Pilot Assembly	x	x	x	x	x
17	9010-064	2 Section Burner	x				
17	9010-065	3 Section Burner		x			
17	9010-066	4 Section Burner			x	x	
17	9010-067	5 Section Burner					x

Dwg. No.	Part No.	Description	I H 6 0 D 3 6 E	I H 8 5 D 4 8 E	I H 1 1 5 D 4 8 E	I H 1 1 5 D 6 0 E	I H 1 1 5 D 6 0 E
18	8109-001	Induced Draft Blower	x	x	x	x	x
19	1921-019	IDB Gasket	x	x	x	x	x
20	8406-051	Pressure Switch	x	x	x	x	x
21	8201-075	DPST Relay 24V Coil	x	x	x	x	x
22	5651-093	Ignition Module	x	x	x	x	x
23	8620-080	Fan/Limit Control	x	x	x	x	x
24	1171-025	Door Pull	x	x	x	x	x
25	8614-001	Junction Box	x	x	x	x	x
26	8201-006	Fan Center	x	x	x	x	x
27	7003-004	16x25x1 Permanent Filter	x	x	x		
27	7003-028	20x25x1.25 Perm. Filter				x	x
29	8406-047	Door Switch	x	x	x	x	x
30	9010-010	Gas Orifice #38	2	3	4	4	5
31	8406-038	Flame Rollout Switch					x
31	8406-046	Flame Rollout Switch	x	x	x	x	
	4046-148	Wiring Diagram	x	x	x	x	x
	8620-040	Pilot Gas Tube W/Fittings	x	x	x	x	x