

REPLACEMENT PARTS MANUAL

HIGH ECONOMY
GAS FIRED FURNACES
MODELS IC60D36A, IC85D42A, IC115D48A

Manual 2110-854 Revision -- Date 9-21-89 Supersedes

* GENERAL NOTES *

*Revised and/or additional pages may be issued from time to time.
*A complete and current manual consists of pages dated as shown in the following **index**.

** INDEX **

<u>Page</u>	<u>Description</u>	<u>Page</u>	<u>Date</u>	<u>Supersedes</u>
	Cabinet Components-- Exploded View	1	9-21-89	
	" "-- Usage List	2	9-21-89	
	Functional Components-- Exploded View	3	9-21-89	
	" "-- Usage List	4	9-21-89	

*** IMPORTANT ***
*****a*****

Contact the installing and/or local Bard distributor for all parts requirements. Make sure you have the complete model and **serial** number available from the unit rating plate.

CABINET COMPONENTS

Dwg. No.	Part No.	Description	I	I	I
			6	8	1
			0	5	5
			3	4	4
			6	2	4
			A	A	8
					A
1	127-039	Lower Base Assembly	X		
1	127-041	Lower Base Assembly		X	
1	127-043	Lower Base Assembly			X
2	501-126	Left Side Assembly	X	X	X
3	501-125	Right Side Assembly	X	X	X
4	508-017	Back Assembly	X		
4	508-018	Back Assembly		X	
4	508-019	Back Assembly			X
5	152-083	Burner Door	X		
5	152-086	Burner Door		X	
5	152-088	Burner Door			X
6	107-074	Top Fill Assembly	X		
6	107-075	Top Fill Assembly		X	
6	107-076	Top Fill Assembly			X
7	126-038	Blower Base	X		
7	126-040	Blower Base		X	
7	126-044	Blower Base			X
8	171-137	Heat Exchanger Assembly	X		
8	171-141	Heat Exchanger Assembly		X	
8	171-146	Heat Exchanger Assembly			X
9	168-002	Internal Flue Baffle Outside	2	3	2
10	168-013	Internal Flue Baffle Inside			2
11	913-0002	Flue Stack Assembly	X	X	
11	913-0004	Flue Stack Assembly			X
12	168-003	Secondary Air Baffle	X		
12	168-008	Secondary Air Baffle		X	
12	168-010	Secondary Air Baffle			X
13	112-029	Ignition Module Bracket	X	X	X
14	152-118	Right Filter Door	X	X	X
15	152-115	Left Filter Door	X		
15	152-116	Left Filter Door		X	
15	152-117	Left Filter Door			X
16	112-028	Door Switch Bracket	X	X	X
17	130-062	Rear Filter Support	X	X	X
18	130-023	Filter Support	X	X	X
19	915-000	Collector Box Assembly	X		
19	915-000	Collector Box Assembly		X	
19	915-000	Collector Box Assembly			X

Date: 9-21-89

FUNCTIONAL COMPONENTS

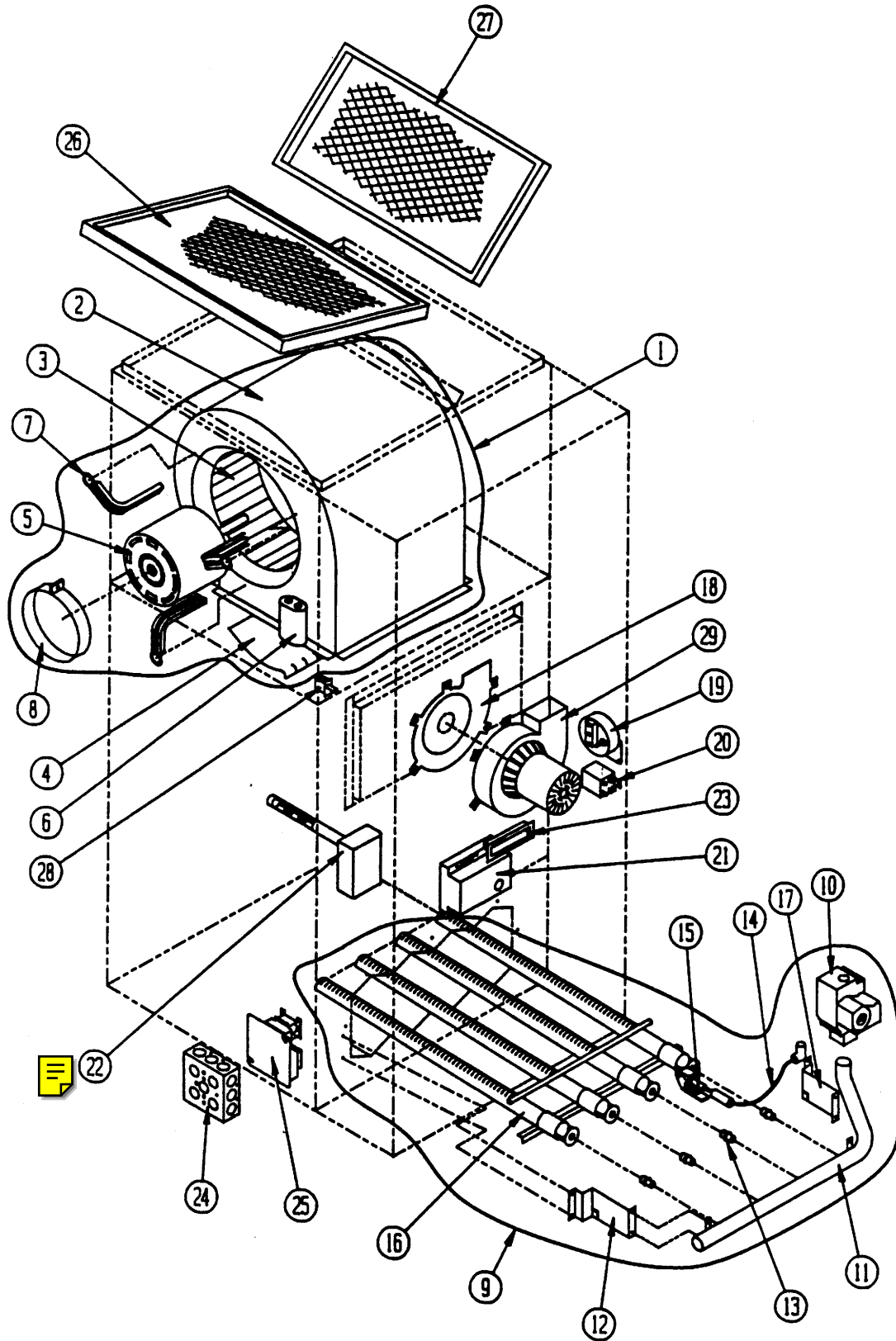

Date: 9-21-89
Supersedes:

FUNCTIONAL COMPONENTS

Dwg. No.	Part No.	Description	I C 6 0 D 3 6 A	I C 8 5 D 4 2 A	I C 1 5 D 4 8 A
1	900-114	Blower Assembly	x		
1	900-116	Blower Assembly		x	
1	900-118	Blower Assembly			x
2	151-075	Blower Housing	x		
2	151-076	Blower Housing		x	
2	151-077	Blower Housing			x
3	5152-010	Blower Wheel	x		
3	5152-014	Blower Wheel		x	
3	5152-059	Blower Wheel			x
4	144-125	Diffuser	x		
4	144-128	Diffuser		x	
4	144-129	Diffuser			x
5	8105-008	Motor	x		
5	8105-009	Motor		x	
5	8106-018	Motor			x
6	8552-002	Capacitor	x	x	
6	8552-004	Capacitor			x
7	8200-036	Motor Mount Arm	3		
7	8200-034	Motor Mount Arm		3	3
8	8200-033	Motor Mount Band	x	x	x
9	901-0074	Blower Assembly	x		
9	901-0050	Blower Assembly		x	
9	901-0061	Blower Assembly			x
10	5651-062	Gas Valve	x	x	x
11	5818-019	Burner Manifold	x		
11	5818-020	Burner Manifold		x	
11	5818-021	Burner Manifold			x
12	112Y095	Left Manifold Bracket	x	x	x
13	9010-010	Gas Orifice #38	2	3	4
14	8600-002	Ignition Cable	x	x	x
15	8554-009	Pilot Burner Assembly	x	x	x
16	9010-036	Burner Venturi 2 Section	x		
16	9010-037	Burner Venturi 3 Section		x	
16	9010-038	Burner Venturi 4 Section			x
17	112X095	Right Manifold Bracket	x	x	x

Dwg. No.	Part No.	Description	I C 6 0 D 3 6 A	I C 8 5 D 4 2 A	I C 1 5 D 4 8 A
18	1921-019	IDB Gasket	x	x	x
19	8406-021	Pressure Switch	x	x	x
20	8201-048	DPST Relay--24V	x	x	x
21	5651-060	Ignition Module	x	x	x
22	912-0004	Fan/Limit Control	x		
22	912-0005	Fan/Limit Control		x	
22	912-0006	Fan/Limit Control			x
23	1171-025	Door Pull	x	x	x
24	8614-001	Junction Box	x	x	x
25	8201-006	2 Speed Fan Center	x	x	x
26	7003-001	Permanent Filter 10x20x1		2	1
27	7003-003	Permanent Filter 15x20x1	1		1
28	8406-013	Door Switch	x	x	x
29	8109-001	Induced Draft Blower	x	x	x

Date: 9-21-89
Supersedes: