

REPLACEMENT PARTS MANUAL

HIGH ECONOMY
GAS FIRED FURNACES
MODELS I L85D42A, I L115D48A, I L145D60A

Manual 2110-855 Revision A Date **1-10-90** Supersedes **9-21-89**

* GENERAL NOTES *

*Revised and/or additional pages may be issued from time to time.
*A complete and current manual consists of pages dated as shown in the following index.

** INDEX **

<u>Page</u>	<u>Description</u>	<u>Page</u>	<u>Date</u>	<u>Supersedes</u>
	Cabinet Components--Exploded View	1	9-21-89	
II	II -- Usage List	2	9-21-89	
	Functional Components--Exploded View	3	9-21-89	
II	II -- Usage List	4	1-10-90	9-21-89

*** IMPORTANT ***

Contact the installing and/or local Bard **distributor** for all parts requirements. Make sure you have the complete model and serial number available from the unit rating plate.

CABINET COMPONENTS

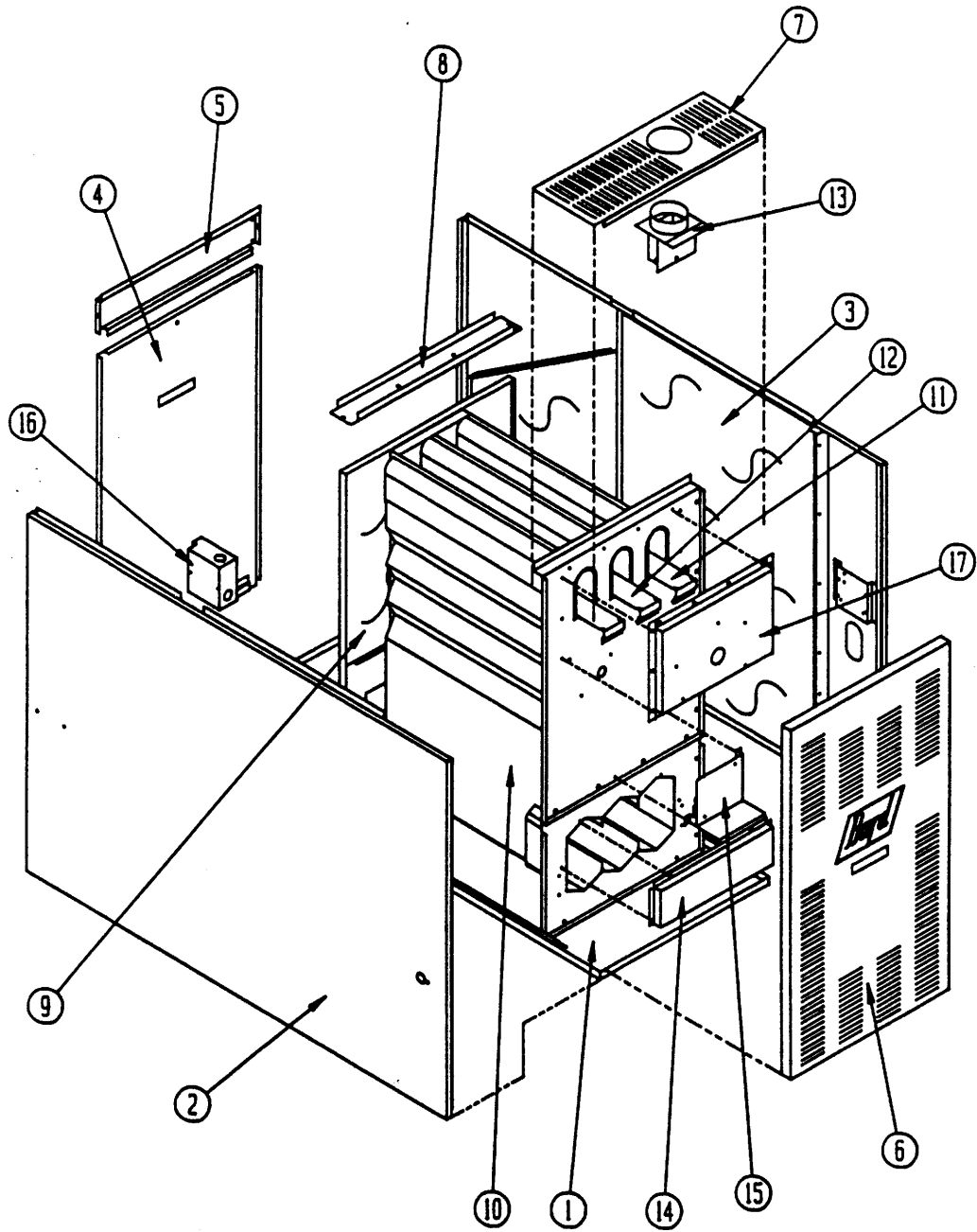

IL85D42A model shown above.

Date: 9-21-89
Supersedes:

CABINET COMPONENTS

Dwg. No.	Part No.	Description	I L 8 5 D 4 2 A	I L 1 1 5 D 4 8 A	I L 1 4 5 D 6 0 A
1	127-099	Base	X		
1	127-100	Base		X	
1	127-101	Base			X
2	501-140	Left Side Assembly	X	X	X
3	501-139	Right Side Assembly	X	X	X
4	553-092	Blower Door Assembly	X		
4	553-094	Blower Door Assembly		X	
4	553-096	Blower Door Assembly			X
5	108-042	Upper Back	X		
5	108-043	Upper Back		X	
5	108-044	Upper Back			X
6	152-093	Burner Door	X		
6	152-095	Burner Door		X	
6	152-097	Burner Door			X
7	106-041	Top Fill	X		
7	106-042	Top Fill		X	
7	106-079	Top Fill			X
8	164-527	Top Channel	X		
8	164-528	Top Channel		X	
8	164-529	Top Channel			X
9	521-072	Blower Partition	X		
9	521-074	Blower Partition		X	
9	521-076	Blower Partition			X
10	171-142	Heat Exchanger Assembly	X		
10	171-147	Heat Exchanger Assembly		X	
10	171-155	Heat Exchanger Assembly			X
11	168-002	Internal Flue Baffle Outside	3	2	4
12	168-013	Internal Flue Baffle Inside		2	1
13	913-0002	Flue Stack Assembly	X		
13	913-0004	Flue Stack Assembly		X	X
14	168-008	Secondary Air Baffle	X		
14	168-010	Secondary Air Baffle		X	
14	168-018	Secondary Air Baffle			X
15	112-029	Ignition Module Bracket	X	X	X
16	116-084	Rear Junction Box	X	X	X
17	913-0006	Collector Box Assembly	X		
17	913-0007	Collector Box Assembly		X	
17	913-0008	Collector Box Assembly			X

Date: 9-21-89

2110-855

Page 2

FUNCTIONAL COMPONENTS

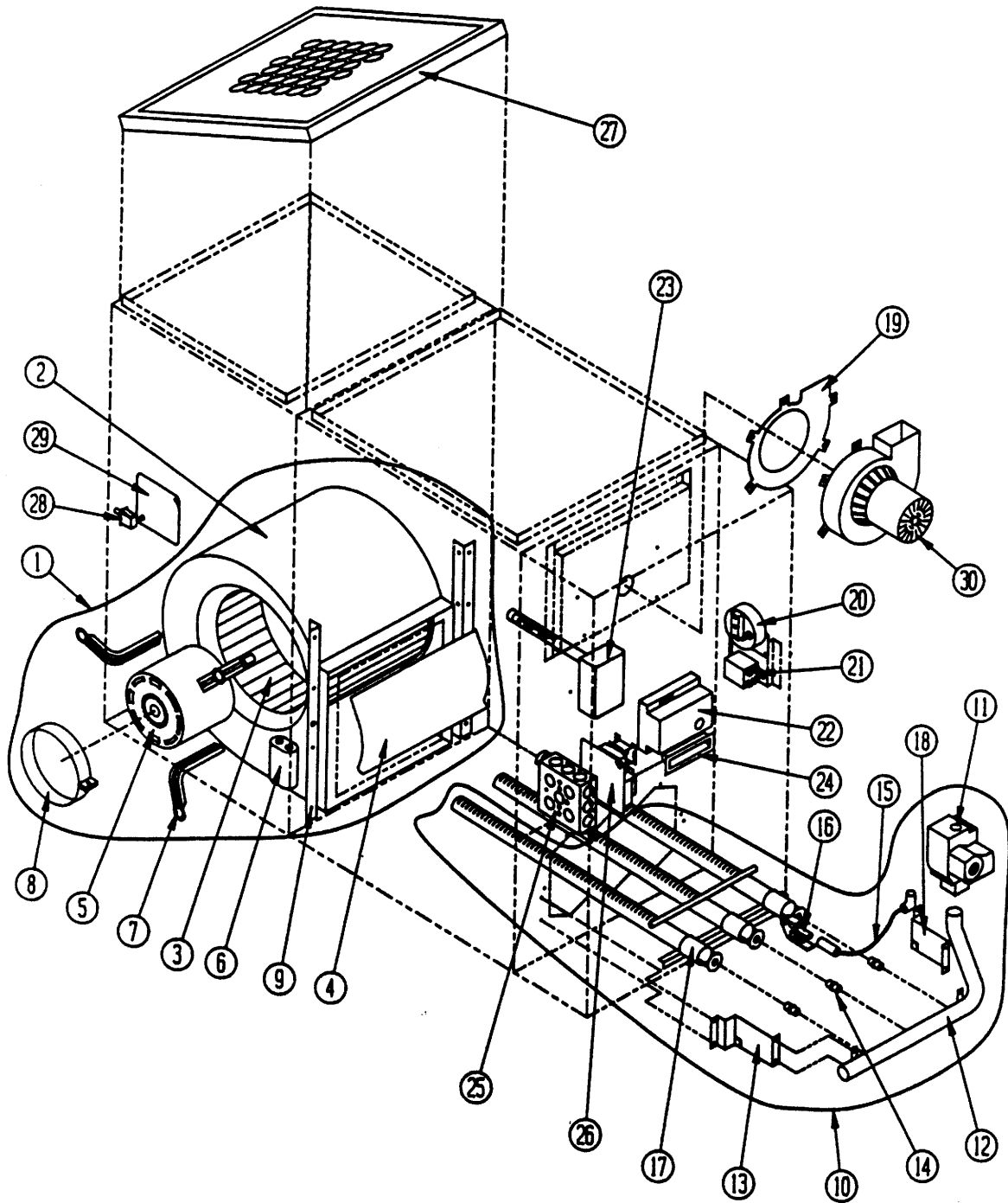

Date: 9-21-89
Supersedes:

FUNCTIONAL COMPONENTS

Dwg. No.	Part No.	Description	I	I	I
			L	L	L
			8	1	1
			5	1	4
			D	5	5
			4	D	D
			2	4	6
			A	8	0
				A	A
1	900-103	Blower Assembly	x		
1	900-104	Blower Assembly		x	
1	900-054	Blower Assembly			x
2	151-073	Blower Housing Assembly	x		
2	151-074	Blower Housing Assembly		x	
2	1 5152-050	Blower Housing Assembly			x
3	5152-014	Blower Wheel	x		
3	5152-059	Blower Wheel		x	
3	5152-053	Blower Wheel			x
4	144-128	Diffuser	x		
4	144-129	Diffuser		x	
4	1 N/A	Diffuser			x
5	8105-009	Motor	x		
5	8106-018	Motor		x	
5	8107-004	Motor			x
6	8552-002	Capacitor	x		
6	8552-004	Capacitor		x	
7	8200-034	Motor Mount Arm	3	3	
7	8200-035	Motor Mount Arm			3
8	8200-033	Motor Mount Band	x	x	x
9	104-794	Blower Angle	2	2	2
10	901-0050	Burner Assembly	x		
10	901-0061	Burner Assembly		x	
10	901-0076	Burner Assembly			x
11	5651-062	Gas Valve	x	x	
11	5651-023	Gas Valve			x
12	5818-020	Manifold 3 Section	x		
12	5818-021	Manifold 4 Section		x	
12	5818-022	Manifold 5 Section			x
13	1127095	Left Manifold Bracket	x	x	x
14	9010-010	Gas Orifice #38	3	4	5
15	8600-002	Ignition Cable	x	x	x
16	8554-009	Pilot Burner Assembly	x	x	x
17	9010-037	Burner 3 Section	x		
17	9010-038	Burner 4 Section		x	
17	9010-039	Burner 5 Section			x

Dwg. No.	Part No.	Description	I	I	I
			L	L	L
			8	1	1
			5	1	4
			D	5	5
			4	D	D
			2	4	6
			A	8	0
				A	A
18	112X095	Right Manifold Bracket	x	x	x
19	1921-019	IDB Gasket	x	x	x
20	8406-021	Pressure Switch	x	x	x
21	8201-048	DPST Relay 24V Coil	x	x	x
22	5651-060	Ignition Module	x	x	x
23	8402-043	Fan/Limit Control	x	x	
23	8402-042	Fan/Limit Control			x
24	1171-025	Door Pull	x	x	x
25	8614-001	Front Junction Box	x	x	x
26	8201-006	Fan Center	x	x	x
27	7003-014	Permanent Filter	x		
27	7003-015	Permanent Filter		x	
27	7003-016	Permanent Filter -			2
28	8406-013	Door Switch	x	x	x
29	8614-029	Cover Plate	x	x	x
30	8109-001	Induced Draft Blower	x	x	x

(1) Balloon No. 2 part No. 5152-050 includes housing, diffuser, and blower wheel part No. 5152-053.

Date: 1-10-90
Supersedes: 9-21-89