

REPLACEMENT PARTS MANUAL

EXTRA HIGH EFFICIENCY II  
CONDENSING GAS FURNACE  
CH--SERIES

Manual 2110-856

Revision B

Date Z-19-90

Supersedes 1-10-90

\*\*\*\*\*  
\* GENERAL NOTES \*  
\*\*\*\*\*

\*Revised and/or additional pages may be issued from time to time.  
\*A complete and current manual consists of pages dated as shown in the following index.

\*\*\*\*\*  
\*\* INDEX \*\*  
\*\*\*\*\*

<u>Page Description</u>	<u>Page</u>	<u>Date</u>	<u>Supersedes</u>
Cabinet Components--Exploded View	1	2-19-90	7-26-89
" " -Usage List	2	2-19-90	1-10-90
Functional Components--Exploded View	3	2-19-90	7-26-89
" " -Usage List	4	2-19-90	1-10-90

\*\*\*\*\*  
\*\*\* IMPORTANT \*\*\*  
\*\*\*\*\*

Contact the installing and/or local Bard distributor for all parts requirements. Make sure you have the complete model and serial number available from the unit rating plate.

UPFLOW CABINET COMPONENT PARTS

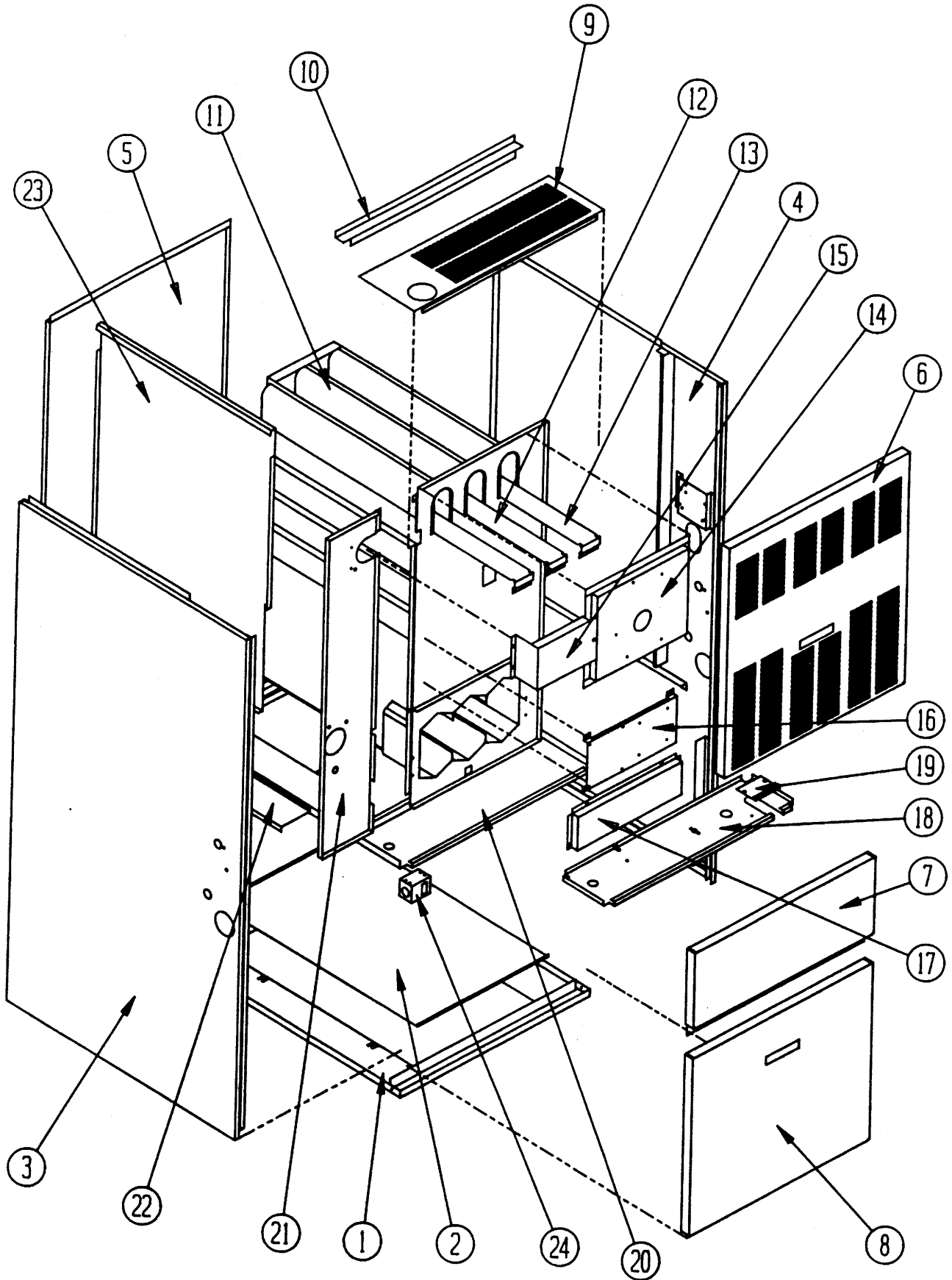

Date: 2-19-90  
Supersedes: 7-26-89

UPFLOW CABINET COMPONENT PARTS LIST

No.	Part No.	Description	C	C	C
			H	H	H
			0	0	1
			6	8	0
			0	0	0
			D	D	D
			3	4	6
			6	8	0
			B	B	B
1	127-125	Lower Base Spotweld Assembly	x		
1	127-127	Lower Base Spotweld Assembly		x	
1	127-148	Lower Base Spotweld Assembly			x
2	136-121	Bottom Fill Plate	x	x	
2	136-133	Bottom Fill Plate			x
3	501-182	Left Side Assembly	x	x	x
4	501-181	Right Side Assembly	x	x	x
5	508-018	Back Assembly	x		
5	508-019	Back Assembly		x	
5	508-073	Back Assembly			x
6	152-148	Vestibule Door	x		
6	152-149	Vestibule Door		x	
6	152-150	Vestibule Door			x
7	152-145	Burner Door	x		
7	152-146	Burner Door		x	
7	152-147	Burner Door			x
8	152-151	Blower Door	x		
8	152-152	Blower Door		x	
8	152-153	Blower Door			x
9	106-111	Top Fill	x		
9	106-112	Top Fill		x	
9	106-113	Top Fill			x
10	140-134	Plenum Support	x		
10	140-135	Plenum Support		x	
10	140-136	Plenum Support			x
11	171-158	Heat Exchanger Assembly	x		
11	171-159	Heat Exchanger Assembly		x	
11	171-160	Heat Exchanger Assembly			x
12	168-013	Flue Baffle--Short		x	x
13	168-002	Flue Baffle	x	x	x
14	913-0039	Flue Collector Box Assembly	x		
14	913-0036	Flue Collector Box Assembly		x	
14	913-0042	Flue Collector Box Assembly			x
15	169-034	IDB Transition	x		
15	169-035	IDB Transition Assembly		x	
15	169-036	IDB Transition Assembly			x
*16	112-088	Ignition Module Bracket	x		
*16	112-100	Control Mounting Bracket		x	x
17	168-003	Secondary Air Baffle	x		
17	168-008	Secondary Air Baffle		x	
17	168-010	Secondard Air Baffle			x

Dwg. No.	Part No.	Description	C	C	C
			H	H	H
			0	0	1
			6	8	0
			0	0	0
			D	D	D
			3	4	6
			6	8	0
			B	B	B
18	120-149	Burner Compartment Partition			x
18	120-147	Burner Compartment Partition	x		
18	120-148	Burner Compartment Partition		x	
19	136-131	Manifold Fill Plate	x	x	
19	136-132	Manifold Fill Plate			x
20	127-149	Blower Base Weld Assembly	x		
20	127-120	Blower Base Weld Assembly		x	
20	127-146	Blower Base Weld Assembly			x
21	520-119	Coil Partition	x	x	x
22	140-133	Support Coil	x	x	x
23	134-098	Coil Shield	x	x	
23	134-099	Coil Shield			x
24	112-031	Door Switch Bracket	x	x	x

\*80,000 and 100,000 ignition module bracket shown.

Date: 2-19-90  
Supersedes: 1-10-90

UPFLOW FUNCTIONAL COMPONENT PARTS

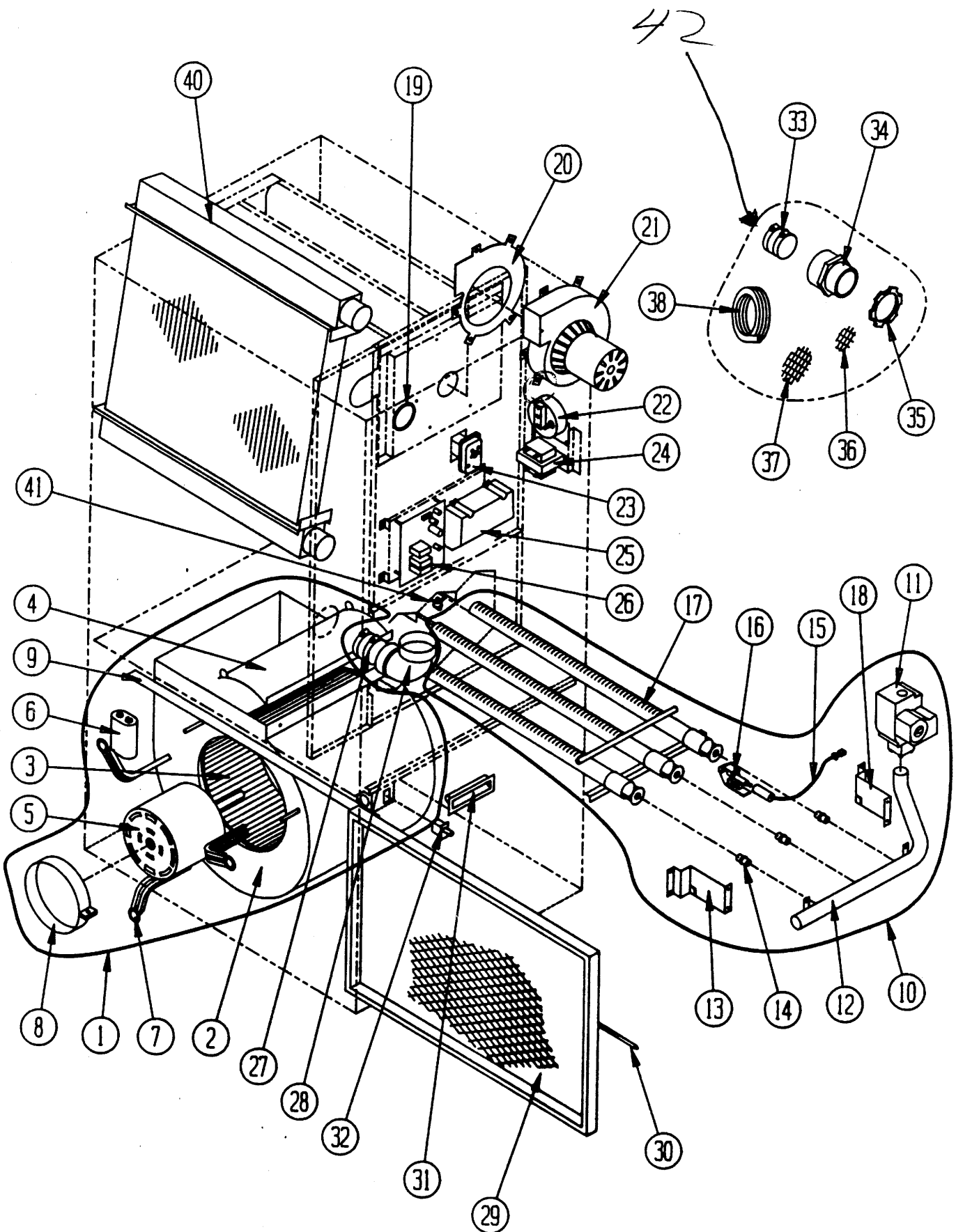

Date: 2-19-90  
Supersedes: 7-26-89

UPFLOW FUNCTIONAL COMPONENT PARTS LIST

No.	Part No.	Description	C H O O D 3 6 B	C H O O D 4 8 B	C H O O D 6 8 B
1	900-100	Blower Assembly	X		
1	900-101	Blower Assembly		X	
1	900-102	Blower Assembly			X
2	151-085	Blower Housing	X		
2	151-074	Blower Housing		X	
2	151-084	Blower Housing			X
3	5152-013	Blower Wheel	X		
3	5152-059	Blower Wheel		X	
3	5152-061	Blower Wheel			X
4	144-127	Diffuser	X		
4	144-129	Diffuser		X	
4	144-131	Diffuser			X
5	8105-008	Motor	X		
5	8106-018	Motor		X	
5	8107-004	Motor			X
6	8552-002	Capacitor	X		
6	8552-004	Capacitor		X	
6	8552-026	Capacitor			X
7	8200-034	Motor Mount Leg	X	X	
7	8200-035	Motor Mount Leg			X
8	8200-033	Motor Mount Strap	X	X	X
9	104-796	Blower Angle	X		
9	104-792	Blower Angle		X	X
10	901-0083	Burner Assembly	X		
10	901-0082	Burner Assembly		X	
10	901-0084	Burner Assembly			X
11	5651-062	Gas Valve	X	X	X
12	5818-019	Gas Manifold	X		
12	5818-020	Gas Manifold		X	
12	5818-021	Gas Manifold			X
13	112Y095	Left Manifold Bracket	X	X	X
14	9010-010	Gas Orifice Spud	X		
14	9010-046	Gas Orifice Spud		X	X
15	8600-009	Ignition Cable	X	X	X
16	8554-009	Pilot Assembly	X	X	X
17	9010-036	Burner Venturi	X		
17	9010-037	Burner Venturi		X	
17	9010-038	Burner Venturi			X
18	112X095	Right Manifold Bracket	X	X	X
19	1921-020	Silicone Die-Cut Gasket	X	X	X
20	1921-019	IDB Gasket	X	X	X
21	8620-033	Induced Draft Blwr Assy Kit	X	X	X

Dwg. No.	Parts No.	Description	C H O O D 3 6 B	C H O O D 4 8 B	C H O O D 6 8 B
22	8406-043	Pressure Switch	X		
22	8406-041	Pressure Switch			X
22	8406-042	Pressure Switch		X	
23	8620-032	Limit Assembly	X	X	X
24	8407-039	Transformer	X	X	X
25	5651-073	Ignition Module	X	X	X
26	8201-053	Blower Control	X	X	X
27	6093-007	"No Hub" Connector	X	X	X
28	6095-005	90 Degree Street Elbow	X	X	X
29	7003-004	16x25xl Permanent	X	X	X
30	5401-002	Filter Spring	X	X	X
31	1171-025	Door Pull	X	X	X
32	8406-013	Door Switch	X	X	X
33	6093-008	"No Hub" Connector	X	X	X
34	6093-006	2" Male Adapter	X	X	X
35	8611-063	2" Conduit Lock Nut	X	X	X
36	7002-009	2" Bird Screen	X	X	X
37	7002-008	3" Bird Screen	X	X	X
38	5452-005-6000	Vinyl Drain Hose	X	X	X
*39	8620-031	Condensate Neutralizer	X	X	X
40	5055-001	Coil Assembly	X	X	X
41	8406-037	Flame Rollout Switch	X	X	X
	4046-108	Wiring Diagram	X	X	X

\*Not pictured.

*0-152 0-29  
TAP  
B...*

Date: 2-19-90  
Supersedes: 1-10-90